

Fully Managed Ethernet Switch 10/100, Gigabit Uplink, SNMP, Modbus/TCP

Models SEC510-2SFP-T, SE512-4SFP-T, SE520-4SFP-T

B+B SMARTWORX

Powered by

ADVANTECH

www.advantech-bb.com

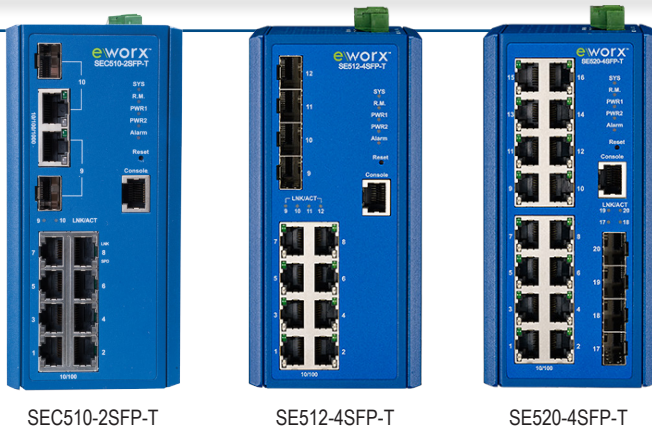

SEC510-2SFP-T

SE512-4SFP-T

SE520-4SFP-T



Features & Benefits

- 8-port 10/100 Mbps + 2-port Gigabit Combo (RJ45 or SFP) Uplink
- 8-port or 16-port 10/100Mbps + 4-port Gigabit SFP Uplink
- Full suite of Layer 2 functionality and advanced diagnostic tools
- Energy Efficient Ethernet (EEE), IEEE 802.3az for low energy consumption
- Jumbo Frame support, up to 9,216 bytes
- IXM™ function enables the cross management for fast deployment
- X-Ring™ function offers self-healing recovery time less than 20 ms
- Redundant Power Inputs (8.4 - 57.6 VDC)
- Wide Temperature Range -40 to 75°C
- EMS Level 3 Radiated/Conducted noise protection
- Designed for UL508 (Industrial Control Panel), NEMA TS2 (Traffic Control), EN50121-4 (Rail Signal Control)



Introduction

The SE500 series is a fully managed Ethernet switch with industrial, ruggedized features designed to work in harsh environment applications. This switch offers all the features expected in a managed switch such as VLAN, IGMP Snooping, Network Redundancy, Link Aggregation, SNMP V1,V2c,V3, Web and Telnet support. Comprehensive network security features such as SSH, HTTPS/SSL, TLS, TTLS, PEAP and Radius are also offered.

Embedded into each switch is the industry leading eWorX IXM™ cross management technology. IXM allows the installer to auto synchronize firmware updates and push configuration setting to either individual or groups of switches. IXM provides maintenance and provisioning functionality to both the SE500 and SE300 family switches without the need of extra software or trained personal. IXM™ speeds up switch deployment and ensures network stability.

The eWorX SE500 series switches feature a powerful suite of diagnostic, monitoring and network performance capabilities: Cable diagnostics, IPv4/IPv6 ping, fiber SFP monitoring (DDMI), port utilization, traffic statistics, QoS and rate limiting - all available from the Web GUI. These advanced features offer quick and easy troubleshooting.

Specifications

INTERFACE	
Connectors	8 x RJ45 + 2 x (RJ45/SFP) combo ports (Model SEC510-2SFP-T) 8 x RJ45 + 4 x SFP ports (Model SE512-2SFP-T) 16 x RJ45 + 2 x SFP ports (Model SE520-2SFP-T) 1 x RS-232 Console port (RJ45 connector) 1 x Reset bottom 6-pin removable screw terminal (power & relay)
Ethernet	Auto Sensing, 10/100BaseTX, 10/100/1000BaseTX, Duplex and MDIX
LED Indicators	PWR1, PWR2, SYS, Alarm and R.M. 10/100 T(X): Link/Activity, Speed Gigabit Copper: Link/Activity, Speed SFP: Link/Activity

L2 Managed Features

- IEEE802.3az** – Energy-Efficient Ethernet (EEE) is a set of enhancements to the twisted-pair and backplane Ethernet computer networking standards that allows for less power consumption during periods of low data activity.
- IXM™** – Offers auto synchronization function of both firmware and configuration settings to make middle/large-scale deployment of multiple switches fast and easy. A built-in Web GUI feature, no need for extra software to be installed on a computer.
- X-Ring™** – Sub-20ms self-healing/ring recovery technology. X-Ring supports different topology options and allows different ring healing methods to coexist in one switch - Couple Ring, Dual Homing and Multi-couple Ring - reduce redundant network cabling and planning costs and ensure high reliability of your industrial network applications
- Multiple Account Access** – allows the network manager to create user accounts with differing permissions. User ID's can be created with a wide variety of access - from simple device monitoring to full maintenance, thus ensuring security and offering flexibility for field deployment.
- IPv6** – A future-proof feature, IPv6 (Internet Protocol version 6) is a set of specifications from the Internet Engineering Task Force (IETF) that is an upgrade of IP version 4 (IPv4). The basics of IPv6 are similar to IPv4 - devices can use IPv6 as source and destination addresses to pass packets over a network.
- IGMP Snooping** – Internet Group Management Protocol allows the managed switch to forward and filter multicast traffic intelligently, designed for the video streaming and automation control network applications.
- DDM** – Digital-diagnostic-monitoring (also known as "digital optical monitoring" or DOM) provides critical information about the status of transmitted and received signals for better fault isolation and error detection.
- Cable Diagnostics** – This feature will enable you to verify the length of a cable right from the switch to the other end. This is essential in diagnosing faults as a break in the cable can be easily identified on a single wire within the cable, as well as shorts and crossed-pairs.
- Dual Image** – Considering possible failures during FW upgrades, such as power failure or human error, dual image provides a backup image in case the system can't boot up through the primary image. The system automatically switches to the backup image to reduce downtime.
- Embedded Watchdog Timer** – This feature, embedded in our managed switches, is used to detect and recover from switch malfunctions when the user cannot easily access the field switch or would be unable to react to faults in a timely manner.
- Ease of Use** – 10/100BaseTX or 10/100/1000 Mbps ports are auto sensing and auto configuring. Each copper port is automatically negotiated for maximum speed and performance by default, but can also be configured individually via the user interface. A powerful inside processor allows wire speed capability on all.

All product specifications are subject to change without notice.

SE/SEC500 series 100 GB-SFP_0717ds

Fully Managed Ethernet Switch

10/100, Gigabit Uplink, SNMP, Modbus/TCP

Models SEC510-2SFP-T, SE512-4SFP-T, SE520-4SFP-T

Software Specifications

SWITCH PROPERTIES	
MAC Table Size	8K
Packet Buffer Size	4.1Mbit
Switching Capacity	5.6 Gbps (SEC510-2SFP-T) 9.6 Gbps (SE512-4SFP-T) 11.2 Gbps (SE520-4SFP-T)
Jumbo Frame	9,216 bytes
Priority Queues	8
Max. Number of Available VLANs	256
VLAN ID Range	VID 1 to 4094
IGMP Groups	256
SOFTWARE	
Management	Web interface, Serial interface (Console), WebAccess NMS™, Multiple user accounts, LLDP, SNMP v1/v2c/v3, Traps, SMTP, RMON, SNMP, Standard MIB, Private MIB
Configuration	HTTP/TFTP, Command line interface (CLI), IPv4/IPv6, TELNET, DHCP server/ client, DHCP option 66/67/82, Flow control, Ingress/Egress Rate limit, Jumbo frame
Security	802.1x, IP Security (Trusted Host), DoS prevention, HTTPS/SSL, SSH, PEAP, RADIUS, Multiple account setting, Storm control, Port-IP Binding, SNMPv3 (Encryption)
Redundancy	X-Ring™ (Self-Recovery time < 20 ms), STP/RSTP/MSTP, LACP (Link Aggregation Control Protocol)
Monitoring	Port statistics & utilization, LLDP/IGMP/MLD statics, Loop detection, Power status
Filter	Multicast (IGMP Snooping/Querier), Unknown multicast filtering, 802.1Q VLAN, Port-based VLAN, GVRP, GARP, Q in Q, QoS (IEEE 802.1p) with 8 classes and TOS/DiffServ, Flow control
Industrial Protocol	Modbus/TCP
Diagnostics	Cable Diagnostic, IPv4/IPv6 Ping Test, Syslog, Port Mirror, DDM (Digital-Diagnostic-Monitoring), Port Mirroring 1:1 and N:1
Enhanced Provisioning	IXM™ Cross management platform for fast deployment, Configuration backup manager, Import/ Export configuration files, firmware upgrades.
Miscellaneous	Remote reboot/reset device, Dual Image, Embedded watchdog timer, Multiple account setting (Admin/User)

Hardware Specifications

POWER	
Power Consumption	12.1W @ 48VDC (System)
Power Input	12 ~ 48 VDC (8.4~57.6 VDC) redundant dual inputs
Fault Output	1 Relay Output
Reverse Polarity Protection	Present
Overload Current	Present
PHYSICAL	
Dimensions (WxHxD)	74 x 152 x 105 mm (2.91 x 5.98 x 4.13 inches)
Protection Class	IP30
Weight	Net: 1.3 kg. Gross: 1.8 kg
Enclosure	Metal Shell
Mounting	DIN Rail, Wall
ENVIRONMENT	
Operating Temperature	-40 to +75°C (-40 to +167°F)
Storage Temperature	-40 to +85°C (-40 to +185°F)
Operating Humidity	10 to 95% (non-condensing)
Storage Humidity	10 to 95% (non-condensing)
MTBF	858,835 hours
CERTIFICATIONS	
Safety	UL508
Traffic Control	NEMA TS2
Rail Signal Control	EN50121-4
EMI	FCC Part 15 Subpart B Class A, EN 55011/55022, Class A
EMS	EN 61000-4-2 (Level 3), EN 61000-4-3 (Level 3) EN 61000-4-4 (Level 3), EN 61000-4-5 (Level 3) EN 61000-4-6 (Level 3), EN 61000-4-8 (Level 3)
Shock	IEC 60068-2-27
Freefall	IEC 60068-2-32
Vibration	IEC 60068-2-6

Product Ordering Information

MODEL #	DESCRIPTION	OPERATING TEMPERATURE	RJ45		FIBER		
			10/100 MBPS	GB	100/1000 BASE-SFP	COMBO PORT, 10/100/1000BASE-T(X) OR 100/1000BASE-SFP	CONNECTOR
SEC510-2SFP-T	8-port 10/100 Mbps + 2 GbE Combo Full Managed Ethernet Switch	-40~75°C	8	-	-	2	LC (SFP)
SE512-4SFP-T	8-port 10/100 Mbps + 4 GbE SFP Full Managed Ethernet Switch	-40~75°C	8	-	4	-	LC (SFP)
SE520-4SFP-T	16-port 10/100 Mbps + 4 GbE SFP Full Managed Ethernet Switch	-40~75°C	16	-	4	-	LC (SFP)

Accessories - Power Supplies (sold separately)

MODEL #	DESCRIPTION	OPERATING TEMPERATURE
MDR-20-24	DIN Rail Power Supply, 24VDC, 20W, 1A	-20~70°C
MDR-40-24	DIN Rail Power Supply, 24VDC, 40W, 1.7A	-20~70°C
SDR-120-24	DIN Rail Power Supply, 24VDC, 120W, 5A	-20~70°C
SDR-240-24	DIN Rail Power Supply, 24VDC, 240W, 10A	-20~70°C

Accessories - WebAccess, Networking Management Software (NMS) (sold separately)

MODEL #	DESCRIPTION
Trial Version	For 6 months free trial, contact your local sales representative.
NMS-U050-ULE	Supports maximum 50 nodes
NMS-U300-ULE	Supports maximum 300 nodes
NMS-U01K-ULE	Supports maximum 1,000 nodes
NMS-U04K-ULE	Supports maximum 4,000 nodes

Package Checklist

Ethernet Switch, RJ45 to DB9 console port cable, Protective caps for unused ports, Quick Start Guide, DIN-Rail mount bracket (installed), wall mount bracket

Warranty

Limited lifetime warranty for B+B SmartWorx designed and/or manufactured products.

Small Form Pluggable (SFP) Modules

Copper SFP (10/100/1000 and 1000 Mbps)

Fiber SFP (155 Mbps, 1.25 Gbps)

- Future-proof network equipment
- Available in SM, MM fiber types
- Maximize network hardware
- Troubleshooting diagnostics
- Plug-and-play operation



Copper



Fiber LC

SFPs are compact transceivers that function as modular connectors. Available for copper (RJ-45) and all common fiber modes, wavelengths and data rates, these modules allow network operators to connect different interface types to the same network equipment via an SFP port. The cost of cable upgrades is greatly reduced, preserving the networking equipment investment – all for the price of a relatively inexpensive module.

More and more network equipment is being designed with SFP ports to take advantage of the inherent flexibility and to eliminate the guesswork and uncertainty of expensive equipment purchases. Remember to select an SFP to match the speed of your designated port. All modules from B+B SmartWorx carry a limited lifetime warranty.

Standard Diagnostics

- SFP Type
- Fiber Link Length
- Wavelength
- Bit Rate
- Date Code

DDMI/Extended Diagnostics

- Temperature
- Voltage
- Bias Current
- TX Power
- RX Power

Fiber SFP Modules

Robust Industrial Performance

- Extended operating temperature range
- Hot swappable

Feature Friendly

- Available in a wide range of fiber types, wavelengths and transmission rates to meet almost any networking need

Extended Diagnostics

- Powerful troubleshooting Digital Diagnostics Monitoring Interface (DDMI)

Standard Compliances

- MSA compliant: available in dual- or single-strand, SC or LC connector
- Eye Safety meets Laser Class 1 Compliance with IEC 60825-1
- Complies with Telecordia GR-468-CORE
- RoHS compliant

Voltage/Temperature

- Input Voltage: 3.3V
- Operating Temperature: -40° to +85° C
- Operating Temperature, CWDM: 0° to +70° C
- Storage Temperature: -40° to +85° C

Data Rates

- 155 Mbps
- ITU-T G.957, G.958 and IEEE 802.3u
 - Applications: Fast Ethernet, OC-3/STM-1 and other optical links
- 1.25 Gbps
- Compliant with specifications for IEEE 802.3z
 - Applications: Gigabit Ethernet and other optical links

Copper SFP Models

MODEL NUMBER	PORT DESCRIPTION	CONNECTOR	DISTANCE
808-39001	10 - 1250, TX	RJ45	100 m
808-39010	1250, TX	RJ45	100 m

IE-SFP Modules: 100 to 155 Mbps, DDMI (OC-3)

MODEL NUMBER	PORT DESCRIPTION	FIBER	DISTANCE	POWER BUDGET
<i>W/ DDMI</i>				<i>(db)</i>
808-38101	MM850	LC	2 km	14.5
808-38102	MM1300	LC	2 km	11
808-38103	SM1310	LC	20 km	21
808-38104	SM1310/PLUS	LC	40 km	31
808-38105	SM1550/LONG	LC	80 km	31

IE-SFP Modules: 1.25 Gbps GB Ethernet, DDMI (OC-24)

MODEL NUMBER	PORT DESCRIPTION	FIBER	DISTANCE	POWER BUDGET
<i>W/ DDMI</i>				<i>(db)</i>
808-38201	MM850	LC	220/550 m	7.5
808-38206	MM1300	LC	2 km	10
808-38200	SM1310	LC	20 km	14
808-38203	SM1310/PLUS	LC	30 km	17
808-38204	SM1550/LONG	LC	40 km	18
808-38205	SM1550/XLONG	LC	70 km	21
808-38208	SM1550/XXLONG	LC	120 km	30

IE-SFP Modules: CWDM (155 Mbps/1.25 Gbps), DDMI

MODEL NUMBER	DESCRIPTION	FIBER	DISTANCE	POWER BUDGET (db)	
				155 Mbps	1.25 Gbps
808-38141	808-38241 CWDM-SM1270	LC	80 km	29	22
808-38142	808-38242 CWDM-SM1290	LC	80 km	29	22
808-38143	808-38243 CWDM-SM1310	LC	80 km	29	22
808-38144	808-38244 CWDM-SM1330	LC	80 km	29	22
808-38145	808-38245 CWDM-SM1350	LC	80 km	29	22
808-38146	808-38246 CWDM-SM1370	LC	80 km	29	22
808-38147	808-38247 CWDM-SM1390	LC	80 km	29	22
808-38148	808-38248 CWDM-SM1410	LC	80 km	29	22
808-38149	808-38249 CWDM-SM1430	LC	80 km	29	22
808-38150	808-38250 CWDM-SM1450	LC	80 km	29	22
808-38151	808-38251 CWDM-SM1470	LC	80 km	29	22
808-38152	808-38252 CWDM-SM1490	LC	80 km	29	22
808-38153	808-38253 CWDM-SM1510	LC	80 km	29	22
808-38154	808-38254 CWDM-SM1530	LC	80 km	29	22
808-38155	808-38255 CWDM-SM1550	LC	80 km	29	22
808-38156	808-38256 CWDM-SM1570	LC	80 km	29	22
808-38157	808-38257 CWDM-SM1590	LC	80 km	29	22
808-38158	808-38258 CWDM-SM1610	LC	80 km	29	22

NOTES: Fiber SFP Form Factors & Distances

Fiber SFP (OC-3, OC-24) form factors have virtually identical dimensions and are not typically interchangeable; this will depend on the device type.

For each fiber product listed in the tables, DISTANCE represents an approximate fiber distance based on industry-standard fiber attenuation specifications. Actual distances will vary for each installation. For complete power budgets and additional information on calculating specific distances, contact B+B SmartWorx Technical Support specialists at (815) 433-5100 (USA).

Fully Managed Ethernet Switch

10/100, Gigabit Uplink, SNMP, Modbus/TCP

Models SEC510-2SFP-T, SE512-4SFP-T, SE520-4SFP-T

Mechanical Diagram | Faceplate Detail by Model

Units = [inches] mm

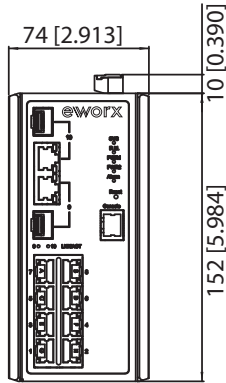

Model SEC510-4SFP-T
faceplate detail

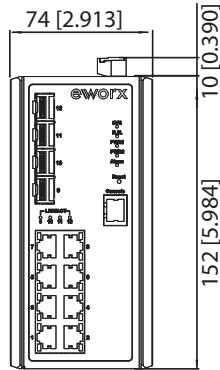

Model SE512-4SFP-T
faceplate detail

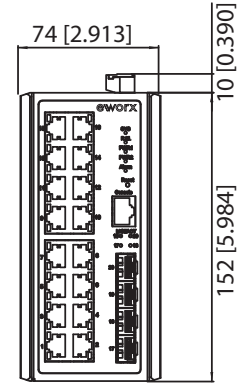

Model SE520-4SFP-T
faceplate detail

Mechanical Diagram | Enclosure DIN Rail & Panel Mount Options

Units = [inches] mm

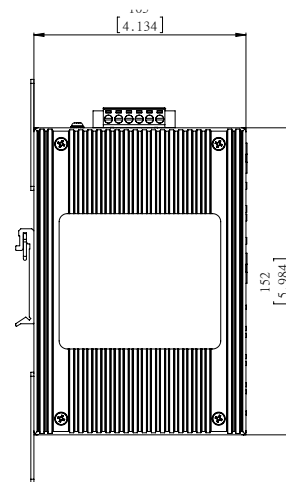
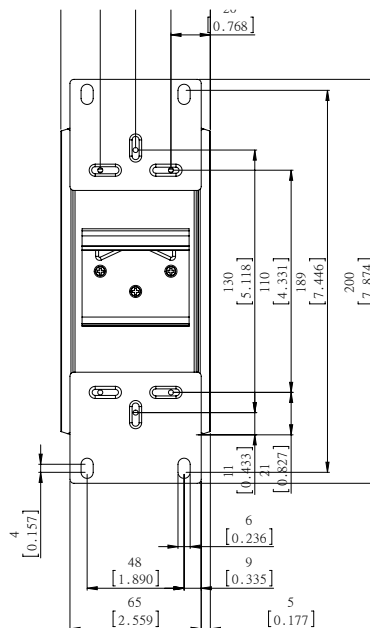
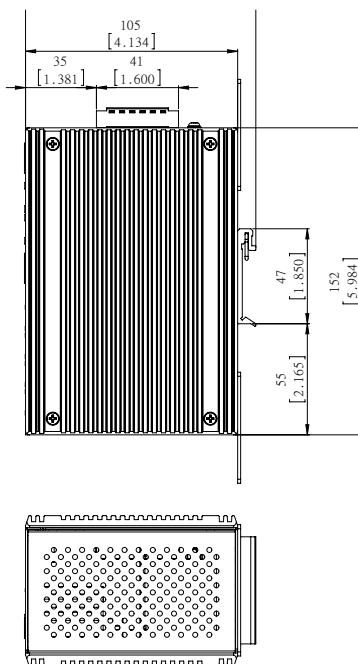
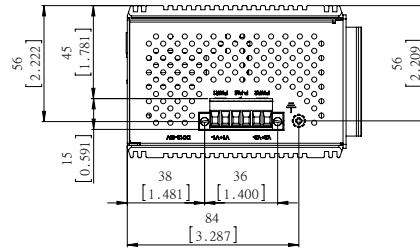

X-ON Electronics

Largest Supplier of Electrical and Electronic Components

Click to view similar products for [Ethernet Modules](#) category:

Click to view products by [B+B SmartWorx](#) manufacturer:

Other Similar products are found below :

[TDKEZW3](#) [V23993-USB1029A](#) [100-POE4](#) [I210T1BLK](#) [X520QDA1](#) [BCM84794A1KFSBG](#) [X520DA2OCP](#) [808-38157](#) [7506GX2](#) [TC](#)
[EXTENDER 2001 ETH-2S](#) [105FX-SC-MDR](#) [110FX2-SC](#) [BCM54291B0IQLEG](#) [7000-P3201-P050150](#) [750-1415](#) [750-494](#) [750-495](#) [750-612](#)
[750-613](#) [750-627](#) [750-643](#) [750-940](#) [753-440](#) [753-540](#) [753-650/003-000](#) [852-1322](#) [852-1328](#) [852-1812](#) [852-1813](#) [852-1816](#) [LANTICK PE-](#)
[0-16](#) [LANTICK PE-16-0](#) [RBMTXLITE-L4X2.X.X.X.X.](#) [USR-TCP232-T2](#) [2017008](#) [EKI-7708E-4F-AE](#) [EKI-7708E-4FP-AE](#) [EKI-7708G-](#)
[4FP-AE](#) [2352903-2](#) [753-620](#) [EGU-0702-SFP-T](#) [SW-125](#) [SW-525](#) [SW-725](#) [1005957](#) [1006191](#) [304TX-N](#) [WIZ107SR_TTL](#) [ES-320](#)
[TDKEZW5](#)