

# Monitored Ethernet Switches

## 5 & 8 port, Gigabit, SNMP, Modbus/TCP

### Models SEG305-T, SEG308-T

B+B SMARTWORX

Powered by

ADVANTECH

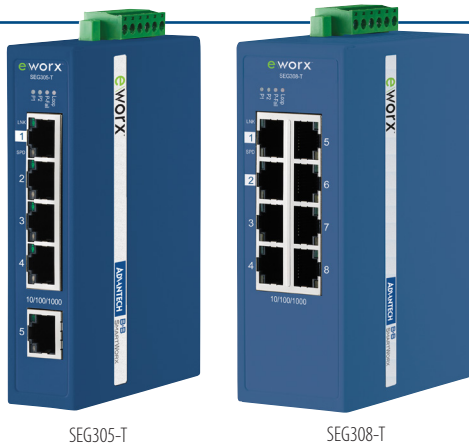

SEG305-T

SEG308-T

eWorX™

Modbus SNMP



### Features & Benefits

- Communicates with HMI/SCADA software via Modbus/TCP
- Integrated with iView<sup>2</sup>- SNMP Management Software (free download)
- Energy Efficient Ethernet (EEE), IEEE 802.3az for low energy consumption
- Wide temperature range -40 to 75°C
- DIN rail or wall/panel mountable
- Redundant dual 12 to 48VDC power inputs
- EMS Level 3 Protection
- Designed for hazardous locations: UL C1D2, ATEX Zone 2 (pending), IECEx (pending)
- Port-based QoS feature for deterministic data transmission
- Loop detection and event alarm
- Power failure indicated by a relay and LED indicator

### Introduction

SE300 series is the industry's first design for Ethernet Green®, IEEE802.3az - Energy Ethernet switches that cut power usage by up to 60%, significantly saving energy usage in the field and reducing total cost of ownership over 24/7.

Advantech B+B SmartWorX SE300 series monitored switches can be used as plug-and-play unmanaged switches right out of the box. Installing the iView<sup>2</sup> Network Management Software gives them basic monitoring and management capabilities as well. They bridge the gap between unmanaged switches and significantly more expensive, fully managed solutions.

When enabled with iView<sup>2</sup>, these switches provide IP address assignment, allowing for a static IP address or an address that is discoverable via DHCP in the network. Then, these switches have the ability to use Modbus/TCP to communicate with HMI/SCADA software and SNMP to communicate with NMS (Networking Management Software) at the same time. This gives full access control to both control engineers and IT managers.

### Basic Monitoring & Management Capabilities

iView<sup>2</sup> gives network managers the ability to monitor and manage eWorX SE300 series switches from a central location. It features an intuitive Graphical User Interface (GUI) that provides a real-life representation of all installed eWorX SE300 Series switches, displaying device functions, port settings, device status information and traffic statistics via SNMP.

iView<sup>2</sup> can also configure eWorX SE300 series switches monitoring capabilities for automation applications via the popular Modbus TCP/IP protocol. Control engineers can use existing HMI/SCADA software to integrate the network status by creating extra tags for real-time monitoring. iView<sup>2</sup> is a standalone software that supports multiple platforms and operating systems.

### iView<sup>2</sup> Features for eWorX SE300 series Switches

#### Monitoring:

- System information (IP/MAC address)
- Port status
- Port speed
- Flow control
- Link up counter
- TX packets counter, RX packets counter
- TX error packets counter, RX error packets counter
- Firmware version
- PoE status (PoE model/s only)

#### Management:

- Configure IP mode
- Set IP address
- Set TCP Modbus/TCP time-out
- Create Community Strings
- Configure Traps

### Specifications

COMMUNICATIONS	
Standards	IEEE 802.3, 802.3u, 802.3x, 802.3ab, 802.3z, 802.1p, 802.3az
LAN	10/100/1000Base-T(X)
Transmission Distance	100 m
Transmission Speed	Up to 1000Mbps
INTERFACE	
Connectors	SEG305-T: 5 x RJ45 SEG308-T: 8 x RJ45 6-pin removable screw terminal (power & relay)
Ethernet	Auto Sensing, 10/100/1000BaseTX, Duplex and MDIX
LED Indicators	P1, P2, P-Fail, Loop Detection 10/100/1000T(X): Link/Activity, Speed

# Monitored Ethernet Switches

## 5 & 8 port, Gigabit, SNMP, Modbus/TCP

### Models SEG305-T, SEG308-T

#### Specifications - continued

SWITCH PROPERTIES	
MAC Table Size	SEG305-T: 2k SEG308-T: 8k
Packet Buffer Size	SEG305-T: 1M bit SEG308-T: 4.1M bit
Switching Capacity	SEG305-T: 10 Gbps SEG308-T: 16 Gbps
Jumbo Frame	9216 bytes
POWER	
Power Consumption	SEG305-T: Max. 2W. SEG308-T: Max. 5.2W
Power Input	12~48 VDC (8.4~52.8VDC) redundant dual inputs
Fault Output	1 Relay Output
Reverse Polarity Protection	Present
Overload Current	Present
PHYSICAL	
Dimensions (WxHxD)	SEG305-T: 27 x 120 x 84 mm. SEG308-T: 43 x 120 x 84 mm
Enclosure	IP30, metal shell with solid mounting kits
Mounting	DIN-Rail, Wall

#### SOFTWARE

Management	iView <sup>2</sup> , LLDP, SNMP v1/v2c, Modbus/TCP
Configuration	Static IP address, DHCP Client
Monitoring	Port Statistics (Speed/Status), Link Up/Down counter, Error Packet counter, Loop detection
Filter	Flow control, IEEE 802.1p QoS(Strict mode), Broadcast storm protection
Industrial Profiles	Modbus/TCP profiles included - Configuration and Diagnostic via automation software tools like e.g. Wonderware InTouch, STEP7, InduSoft Web Studio

#### IVIEW<sup>2</sup> - NETWORK MANAGEMENT SOFTWARE - FREE DOWNLOAD

Version	iView <sup>2</sup> Web-based Application
OS Support	32-bit/64-bit Windows XP/Vista/7, Windows Server 2003/2008/2008 R2
Operation Modes	Local Computer or Remote Server
Web Browser	Microsoft® IE, Chrome, Firefox
Protocol	SNMPv1 and SNMPv2c

#### Product Ordering Information

MODEL #	DESCRIPTION	OPERATING TEMPERATURE	RJ45		FIBER					
			10/100 MBPS	GIGABIT	100FX	100/1000BASE-SFP	COMBO PORT, 10/100/1000BASE-T(TX) OR 100/1000BASE-SFP	TYPE	CONNECTOR	
SEG305-T	5-port Gigabit Monitored Ethernet Switch	-40~75°C	-	5	-	-	-	-	-	-
SEG308-T	8-port Gigabit Monitored Ethernet Switch	-40~75°C	-	8	-	-	-	-	-	-

#### Accessories - optional

MODEL #	DESCRIPTION
MDR-40-24	DIN Rail Power supply, 24VDC 40 Watt
CSUMB3FBG	3 ft. (1 M), Gray, Category 5e UTP Patch Cord
CSUMB7FBG	7 ft. (2 M), Gray, Category 5e UTP Patch Cord

#### Specifications - continued

ENVIRONMENT	
Operating Temperature	-40 ~ 75°C (-40 ~ 167°F)
Storage Temperature	-40 ~ 85°C (-40 ~ 185°F)
Operating Humidity	10 ~ 95% (non-condensing)
Storage Humidity	10 ~ 95% (non-condensing)
MTBF	SEG305-T: 5,168,110 hours SEG308-T: 4,176,861 hours
CERTIFICATIONS	
Hazardous Environments	UL Class 1 Division 2 Groups A,B,C,D; ATEX Zone 2 (pending); IECEx (pending)
Safety	UL508
EMI	FCC Part 15 Subpart B Class A, EN 55011/55022, Class A
EMS	EN 61000-4-2 (Level 3), EN 61000-4-3 (Level 3) EN 61000-4-4 (Level 3), EN 61000-4-5 (Level 3) EN 61000-4-6 (Level 3), EN 61000-4-8 (Level 3)
Shock	IEC 60068-2-27
Freefall	IEC 60068-2-32
Vibration	IEC 60068-2-6

#### Package Checklist

Ethernet Switch, Quick Start Guide, DIN-Rail mount bracket (installed), Wall mount bracket

#### Warranty

Limited lifetime warranty for Advantech B+B designed and/or manufactured products.

## Model SEG305-T Mechanical Diagram | DIN Rail & Panel Mount Options

Units = [inches] mm

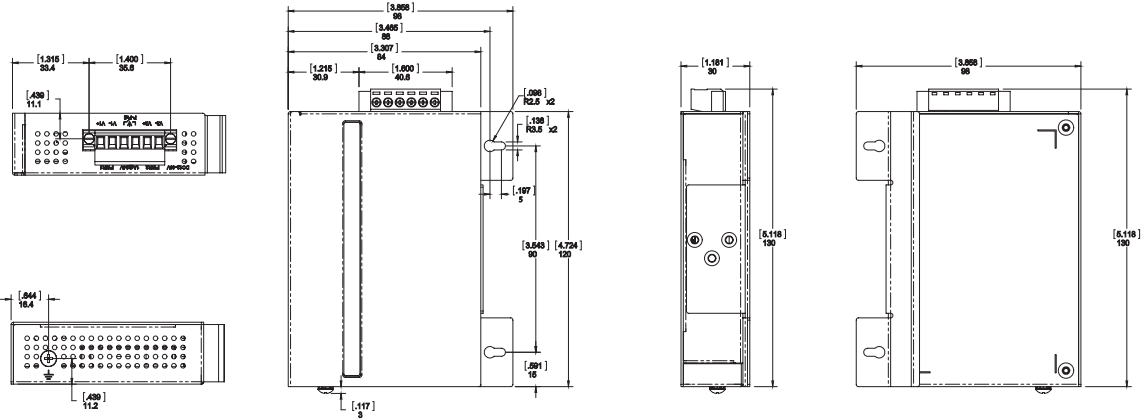
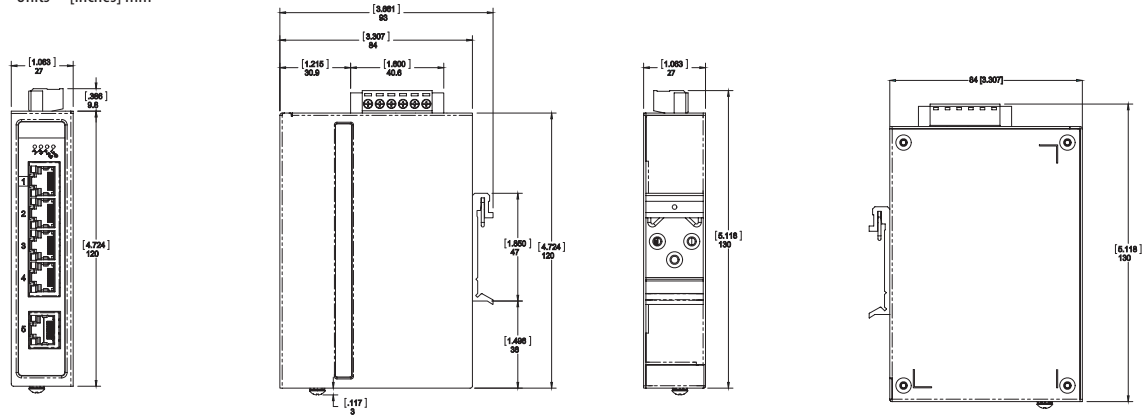

## SEG308-T Mechanical Diagram | DIN Rail & Panel Mount Options

Units = [inches] mm

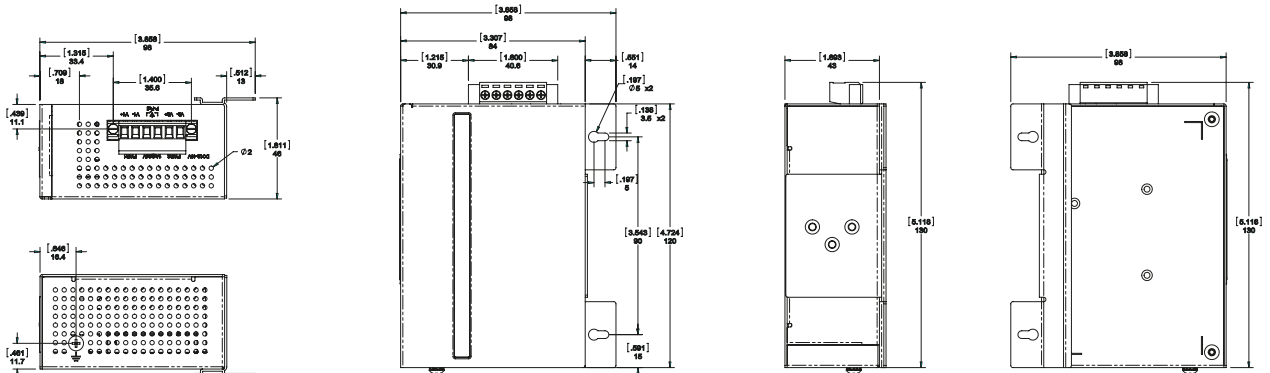
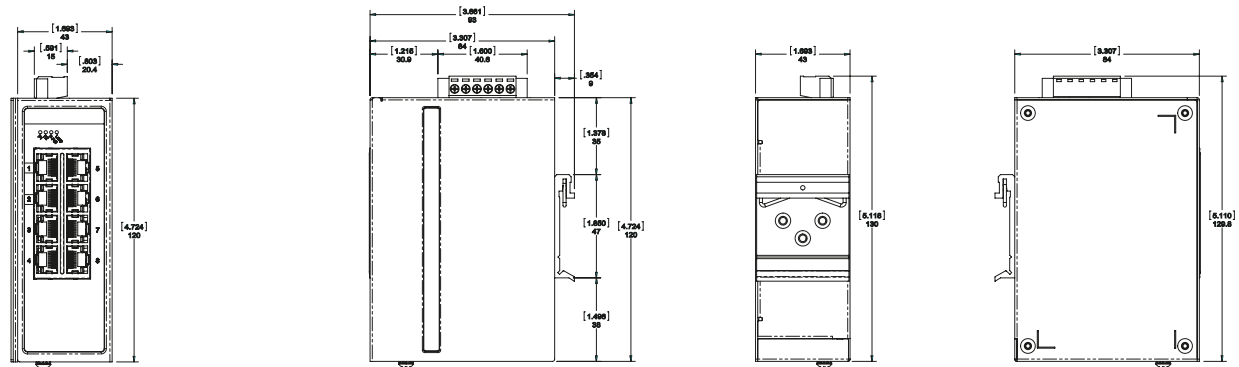

## X-ON Electronics

Largest Supplier of Electrical and Electronic Components

*Click to view similar products for [Ethernet Modules](#) category:*

*Click to view products by [B+B SmartWorx](#) manufacturer:*

Other Similar products are found below :

[TDKEZW3](#) [V23993-USB1029A](#) [100-POE4](#) [I210T1BLK](#) [X520QDA1](#) [BCM84794A1KFSBG](#) [X520DA2OCP](#) [808-38157](#) [7506GX2](#) [TC](#)  
[EXTENDER 2001](#) [ETH-2S](#) [105FX-SC-MDR](#) [110FX2-SC](#) [7000-P3201-P050150](#) [750-1515](#) [750-494](#) [750-495](#) [750-497](#) [750-501](#) [750-612](#)  
[750-613](#) [750-627](#) [750-643](#) [750-940](#) [753-440](#) [753-540](#) [753-650/003-000](#) [852-1322](#) [852-1328](#) [852-1812](#) [852-1813](#) [852-1816](#) [LANTICK PE-](#)  
[0-16](#) [LANTICK PE-16-0](#) [RBMTXLITE-L4X2.X.X.X.X.](#) [USR-TCP232-T2](#) [2017008](#) [EKI-7708E-4F-AE](#) [EKI-7708E-4FP-AE](#) [EKI-7708G-](#)  
[4FP-AE](#) [2352903-2](#) [753-620](#) [EGU-0702-SFP-T](#) [EKI-2706G-1GFPI-BE](#) [SW-125](#) [SW-525](#) [SW-725](#) [7000-74712-4780030](#) [7000-74712-](#)  
[4780060](#) [7000-74712-4780100](#) [7000-74712-4780150](#)