

X15

System Reference Manual

Revision B1
July 22, 2016

Author:
Gerald Coley Gcoley1@emprodesign.com

THIS DOCUMENT

This work is licensed under the Creative Commons Attribution-Share Alike 3.0 Unported License. To view a copy of this license, visit <http://creativecommons.org/licenses/by-sa/3.0/> or send a letter to Creative Commons, 171 Second Street, Suite 300, San Francisco, California, 94105, USA.

All derivative works are to be attributed to Gerald Coley of BeagleBoard.org.

For more information, see

<http://creativecommons.org/licenses/by-sa/3.0/>

For any questions, concerns, or issues submit them to gerald@BeagleBoard.org

DESIGN

These design materials referred to in this document are ***NOT SUPPORTED*** and **DO NOT** constitute a reference design. Only “community” support is allowed via resources at BeagleBoard.org/discuss.

THERE IS NO WARRANTY FOR THE DESIGN MATERIALS, TO THE EXTENT PERMITTED BY APPLICABLE LAW. EXCEPT WHEN OTHERWISE STATED IN WRITING THE COPYRIGHT HOLDERS AND/OR OTHER PARTIES PROVIDE THE DESIGN MATERIALS “AS IS” WITHOUT WARRANTY OF ANY KIND, EITHER EXPRESSED OR IMPLIED, INCLUDING, BUT NOT LIMITED TO, THE IMPLIED WARRANTIES OF MERCHANTABILITY AND FITNESS FOR A PARTICULAR PURPOSE. THE ENTIRE RISK AS TO THE QUALITY AND PERFORMANCE OF THE DESIGN MATERIALS IS WITH YOU. SHOULD THE DESIGN MATERIALS PROVE DEFECTIVE, YOU ASSUME THE COST OF ALL NECESSARY SERVICING, REPAIR OR CORRECTION.

We mean it; these design materials may be totally unsuitable for any purposes.

**UNITED STATES FCC AND CANADA IC REGULATORY COMPLIANCE
INFORMATION****The BeagleBone is annotated to comply with Part 15 of the FCC Rules.**

Operation is subject to the following two conditions: (1) This device may not cause harmful interference, and (2) this device must accept any interference received, including interference that may cause undesired operation. Changes or modifications not expressly approved by the party responsible for compliance could void the user's authority to operate the equipment.

This Class A or B digital apparatus complies with Canadian ICES-003. Changes or modifications not expressly approved by the party responsible for compliance could void the user's authority to operate the equipment. Cet appareil numérique de la classe A ou B est conforme à la norme NMB-003 du Canada. Les changements ou les modifications pas expressément approuvés par la partie responsable de la conformité ont pu vider l'autorité de l'utilisateur pour actionner l'équipement.

BeagleBoard.org provides the enclosed product(s) under the following conditions:

This evaluation board/kit is intended for use for **ENGINEERING DEVELOPMENT, DEMONSTRATION, OR EVALUATION PURPOSES ONLY** and is not considered by BeagleBoard.org to be a finished end-product fit for general consumer use. Persons handling the product(s) must have electronics training and observe good engineering practice standards. As such, the goods being provided are not intended to be complete in terms of required design-, marketing-, and/or manufacturing-related protective considerations, including product safety and environmental measures typically found in end products that incorporate such semiconductor components or circuit boards. This evaluation board/kit does not fall within the scope of the European Union directives regarding electromagnetic compatibility, restricted substances (RoHS), recycling (WEEE), FCC, CE or UL, and therefore may not meet the technical requirements of these directives or other related directives.

Should this evaluation board/kit not meet the specifications indicated in the User's Guide, the board/kit may be returned within **30 days** from the date of delivery for a full refund to the distributor from which you purchased the board. **THE FOREGOING WARRANTY IS THE EXCLUSIVE WARRANTY MADE BY SELLER TO BUYER AND IS IN LIEU OF ALL OTHER WARRANTIES, EXPRESSED, IMPLIED, OR STATUTORY, INCLUDING ANY WARRANTY OF MERCHANTABILITY OR FITNESS FOR ANY PARTICULAR PURPOSE.**

The user assumes all responsibility and liability for proper and safe handling of the goods. Further, the user indemnifies BeagleBoard.org from all claims arising from the handling or use of the goods. Due to the open construction of the product, it is the user's responsibility to take any and all appropriate precautions with regard to electrostatic discharge.

EXCEPT TO THE EXTENT OF THE INDEMNITY SET FORTH ABOVE, NEITHER PARTY SHALL BE LIABLE TO THE OTHER FOR ANY INDIRECT, SPECIAL, INCIDENTAL, OR CONSEQUENTIAL DAMAGES.

BeagleBoard.org currently deals with a variety of customers for products, and therefore our arrangement with the user **is not exclusive**. BeagleBoard.org assumes **no liability for applications assistance, customer product design, software performance, or infringement of patents or services described herein.**

Please read the System Reference Manual and, specifically, the Warnings and Restrictions notice in the User's Guide prior to handling the product. This notice contains important safety information about temperatures and voltages. For additional information on BeagleBoard.org environmental and/or safety programs, please visit BeagleBoard.org.

No license is granted under any patent right or other intellectual property right of BeagleBoard.org covering or relating to any machine, process, or combination in which such BeagleBoard.org products or services might be or are used.

Mailing Address:
BeagleBoard.org
4467 Ascot Ct.
Oakland TWP, MI 48306 U.S.A

WARRANTY: *The BeagleBoard is warranted against defects in materials and workmanship for a period of 90 days from purchase. This warranty does not cover any problems occurring as a result of improper use, modifications, exposure to water, excessive voltages, abuse, or accidents. All boards will be returned via standard mail if an issue is found. If no issue is found or express return is needed, the customer will pay all shipping costs.*

Before returning the board, please visit
BeagleBoard.org/support

For up to date SW images and technical information refer to
<http://circuitco.com/support/index.php?title=BeagleBone>

Please refer to **Section 9** of this document for the board checkout procedures.
To return a defective board, please request an RMA at
<http://BeagleBoard.org/support/rma>

Please DO NOT return the board without approval from the RMA team first.

All boards received without RMA approval will not be worked on.

Table of Contents

FIGURES	8
TABLES	10
1.0 INTRODUCTION	11
2.0 CHANGE HISTORY	11
3.0 QUICK START SECTION	12
3.1 WHAT'S THE IN THE BOX.....	12
3.2 BOARD DETAILS	13
3.2.1 TOP Side and BOTTOM Edge.....	13
3.2.2 Top Side Connector Details.....	14
3.2.3 TOP Edge and Bottom Side	16
3.2.4 Bottom Side Details	17
3.2.5 Top Side Major Components	19
3.2.6 Top Side Major Component Details	20
3.3 CHECK IT OUT.....	22
3.3.1 What is needed.....	22
3.3.2 SETUP INSTRUCTIONS	25
3.4 PLUG IN YOUR CABLES	26
3.4.1 ETHERNET	26
3.4.2 HDMI.....	26
3.4.3 eSATA	26
3.4.4 Keyboard and Mouse.....	27
3.4.5 AUDIO.....	27
3.4.6 Micro SD Card	28
3.4.7 USB Client.....	28
3.4.8 Serial Debug.....	28
3.4.9 Terminal Setup.....	29
3.4.10 Plug in Power Cable.....	29
3.4.11 Power LEDS	30
3.4.12 Turn ON HDMI monitor	30
3.4.13 Turn ON X15 Power	31
3.4.14 User LEDS	31
3.4.15 BOOTING	32
3.4.16 Boot Strapping	32
3.4.17 FAN Connection	33
3.4.18 FAN Mounting	33
3.5 TESTING.....	34
3.5.1 DEBUG.....	35
3.5.2 ETHERNET	36
3.5.3 SPEAKERS	37
3.5.4 eSATA	41
3.5.5 POWER ON and RESET.....	42
3.5.6 HIGH TEMP CAUTION.....	44
4.0 HARDWARE DESIGN OVERVIEW	45
4.1 FEATURES	46
4.2 BLOCK DIAGRAM.....	47
4.3 POWER SUBSYSTEM	48
4.3.1 Input Power and Conditioning	48
4.3.2 PMIC	49
4.3.3 Indicators.....	51

4.3.4	<i>Voltage Clamp Circuits</i>	51
4.3.5	<i>USB Power Bus</i>	52
4.4	AM5728 PROCESSOR	53
4.5	MEMORY BLOCK DIAGRAM	54
4.6	DDR3L	55
4.6.1	<i>DDR3 Terminations Regulator</i>	55
4.6.2	<i>DDR3 Terminations Resistors</i>	56
4.6.3	<i>Processor Interface</i>	57
4.6.4	<i>DDR3L Connections</i>	58
4.7	4G EMMC	59
4.8	EEPROM	59
4.9	USD CONNECTOR	60
4.10	BOOT MODES	60
4.11	I2C1 BUS	62
4.12	ETHERNET	63
4.12.1	<i>Ethernet 0 Processor Interface</i>	64
4.12.2	<i>Ethernet PHY Power</i>	65
4.12.3	<i>Ethernet 0 RJ45 Connections</i>	66
4.12.4	<i>Ethernet 1 RJ45 Connections</i>	67
4.13	HDMI	68
4.1	AUDIO	69
4.1.1	<i>Processor Interface</i>	69
4.1.2	<i>Power Circuitry</i>	70
4.1.3	<i>Audio In/Out</i>	71
4.2	USB 2.0 CLIENT PORT	72
4.3	USB 3.0 AND HUB	74
4.3.1	<i>Processor and HUB Interface</i>	74
4.3.2	<i>USB3 Port Power Control</i>	75
4.3.3	<i>USB3 Port Connectors</i>	76
4.4	eSATA/SATA	77
4.5	SERIAL DEBUG PORT	79
4.6	JTAG CONNECTOR	80
4.7	TEMPERATURE SENSOR	80
4.8	REAL TIME CLOCK	81
4.9	USER LEDS	82
4.10	FORGOTTEN PINS	83
5.0	EXPANSION CONNECTORS	84
5.1	EXPANSION HEADER PINOUTS	84
5.1	CREATING AND EXPANSION BOARD	85

Figures

Figure 1.	BeagleBoard-X15	12
Figure 2.	X15 Top Side View	13
Figure 3.	X15 Front Edge View	14
Figure 4.	BAT1 Location	15
Figure 5.	X15 Top Edge View	16
Figure 6.	Bottom Side of X15	17
Figure 7.	Location of Major ICs.....	19
Figure 8.	Desktop Configuration.....	25
Figure 9.	Ethernet Ports.....	26
Figure 10.	HDMI Ports.....	26
Figure 11.	eSATA/USB Port.....	26
Figure 12.	Keyboard Transmitter	27
Figure 13.	Audio Jacks.....	27
Figure 14.	MicroSD Card Cage.....	28
Figure 15.	USB Client Connector	28
Figure 16.	Serial Debug Port.....	28
Figure 17.	Terminal Window Setup.....	29
Figure 18.	DC Jack Into P1	29
Figure 19.	DC 12V LED	30
Figure 20.	Monitor Power Button	30
Figure 21.	Power LEDs.....	31
Figure 22.	User LEDs.....	31
Figure 23.	Terminal Window Showing Boot	32
Figure 24.	Boot Strap Resistors.....	32
Figure 25.	Fan Connector.....	33
Figure 26.	Fan Installation.....	33
Figure 27.	X15 test Setup.....	34
Figure 28.	Terminal Window	35
Figure 29.	Debian Desktop.....	36
Figure 30.	Open Web Browser.....	36
Figure 31.	Default Home Page.....	37
Figure 32.	Insert USB Flash Drive.....	37
Figure 33.	Adjacent USB Devices	38
Figure 34.	Media Insertion Notice	39
Figure 35.	Open And Play Sound File	39
Figure 36.	Volume Adjust.....	40
Figure 37.	eSATA Cable and Drive	41
Figure 38.	Attached eSATA Drive Notice	42
Figure 39.	Powering Off Using Shutdown Command	43
Figure 40.	Reset Button S2.....	43
Figure 41.	X15 Heat Zone.....	44
Figure 42.	System Block Diagram	47
Figure 43.	System Power Management Block Diagram	48
Figure 44.	TPS650374 Block Diagram	49

Figure 45.	Voltage Clamps.....	51
Figure 46.	USB 5V Switcher.....	52
Figure 47.	AM5728 Block Diagram.....	53
Figure 48.	System Memory Block Diagram	54
Figure 49.	DDR3 Termination Voltages	55
Figure 50.	DDR3 Termination Resistors.....	56
Figure 51.	DDR3 Processor Interface	57
Figure 52.	DDR3L Memory Device connections	58
Figure 53.	eMMC Circuitry.....	59
Figure 54.	EEPROM Circuitry.....	59
Figure 55.	uSD Circuitry	60
Figure 56.	Boot Pin Settings.....	61
Figure 57.	I2C1 Bus	62
Figure 58.	Ethernet System Block Diagram.....	63
Figure 59.	Ethernet 0 Processor Interface	64
Figure 60.	Ethernet Power Diagram.....	65
Figure 61.	Ethernet RJ45 Interface.....	66
Figure 62.	Ethernet 1 RJ45 Interface.....	67
Figure 63.	HDMI Interface Circuitry	68
Figure 64.	Stereo CODEC Processor Interface	69
Figure 65.	AIC3104 Power Circuitry	70
Figure 66.	Stereo CODEC Audio Connections.....	71
Figure 67.	USB Client Port	72
Figure 68.	Alternate VBUS Detect Circuitry	73
Figure 69.	USB3 and HUB Processor Interface.....	74
Figure 70.	USB3 Power Control	75
Figure 71.	USB Port 1 Connectors.....	76
Figure 72.	USB Port 2 and 3 Connectors	76
Figure 73.	eSATA Block Diagram.....	77
Figure 74.	eSATA Circuitry.....	78
Figure 75.	Debug Serial Port.....	79
Figure 76.	FTDI USB to Serial Adapter.....	79
Figure 77.	JTAG Port.....	80
Figure 78.	Temperature Sensor Circuitry.....	80
Figure 79.	Real Time Clock Circuitry.....	81
Figure 80.	User LEDs Circuitry	82
Figure 81.	Forgotten Pins	83
Figure 82.	Expansion Connector	84
Figure 83.	Expansion Board Measurements.....	85
Figure 84.	Expansion Mating Expansion Connector.....	86
Figure 85.	X15 Top Side View	87
Figure 86.	X15 Bottom Side View	88

Tables

Table 1.	Change History	11
Table 2.	List of Needed Accessories.....	22
Table 3.	BeagleBoard –X15 Features	46
Table 4.	Power, Current, Sequencing and Distribution	50
Table 5.	Boot Options	60
Table 6.	I2C1 Device Address	62
Table 7.	User LED GPIO Mapping	82

1.0 Introduction

This document is the **System Reference Manual** for the BeagleBoard X15 which is based on the TI AM5728 processor. This document covers the features and design of the board.

2.0 Change History

This section describes the change history of this document.

Table 1. Change History

Rev	Changes	Date	By
0.1	Preliminary release.	7/23/2015	EPD
0.2	Added pictures, connector details, accessories list	10/19/2015	EPD
A2	Limited Production Release	5/13/2016	EPD
B1	Update pictures	7/22/2016	EPD

3.0 Quick Start Section

3.1 What's the in the box

In the box you will find a BeagleBoard-X15 board inside an ESD bag.

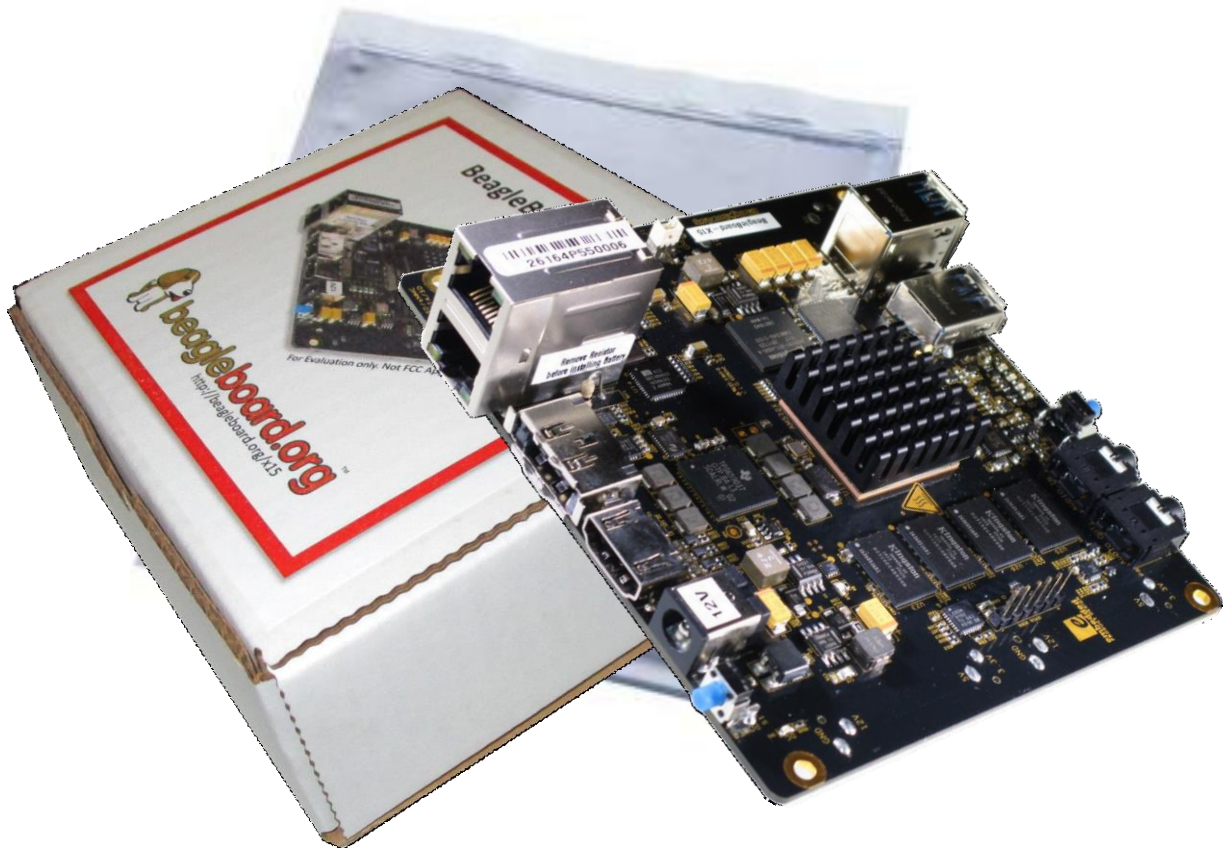

Figure 1. BeagleBoard-X15

3.2 Board Details

This section calls out key connectors and components on the board and provides a brief description of each.

3.2.1 TOP Side and BOTTOM Edge

Shown without the heatsink installed.

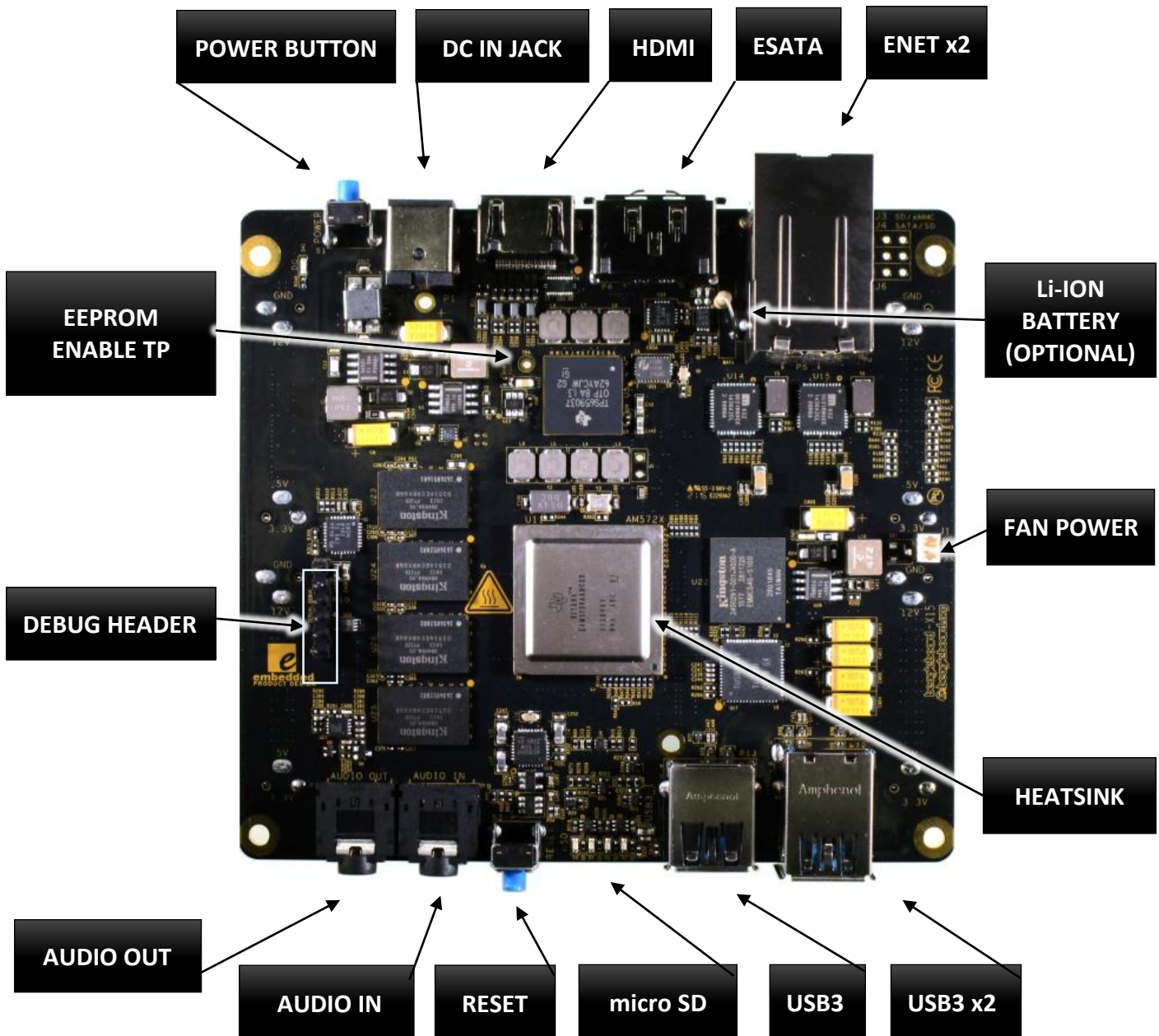

Figure 2. X15 Top Side View

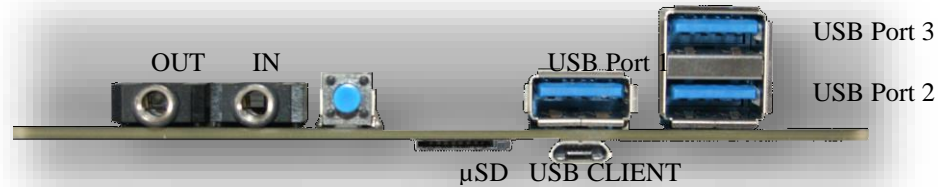

Figure 3. X15 Front Edge View

3.2.2 Top Side Connector Details

- **P5 ETHERNET x2**
 - Stacked RJ45 Jack with LEDs and integrated magnetics
 - Port Location shown in Figure 4
- **P6 ESATA/USB**
 - eSATA - USB Type A Receptacle Combo
 - Powered interface at 500mA
 - Powers HDD or SSD drives from 5V supply
- **P11 HDMI**
 - HDMI Type A - 19 Position Surface Mount, Right Angle
- **P1 DC JACK**
 - CONN PWR JACK DC 2.5X5.5 8A T/H
- **S1 POWER BUTTON**
 - Tactile SPST-NO 0.05A Momentary Switch
 - Hold 12 seconds to power OFF the board
- **P2-P3 CURRENT MONITOR SECTION**
 - Power Taps used for power measurements
 - 100mil pin headers need to be installed prior to taking measurements
- **P10 DEBUG HEADER**
 - Same as used on BeagleBone Black
 - See section 3.4.8 for details
- **P8-P9 AUDIO OUT/IN**
 - Standard 3.5mm jacks

- Stereo Audio Connector Jacks with single switch
- **S2 RESET BUTTON**
 - Momentary Tactile SPST-NO Switch
- **P12 Micro SD Card Cage**
 - ALPS Push-Push Type – Reverse mounting – Micro SD Connector
 - Insert microSD card face up
- **P13-P15 USB 3.0 CONNECTORS**
 - SuperSpeed Panel Mount USB3.0 connectors
 - Port numbering shown in Figure 3.
 - **NOTE:** Use narrower drives when plugging both Port-1 and Port-2
- **HEATSINK**
 - CPU 1.01” SQ with Vertical Fins and thermal tape adhesive backing
 - Fins spaced to support 4-40 screws that can hold an added CPU FAN
- **J1 FAN SOCKET**
 - The X15 can support a CPU FAN
 - The Fan can be purchased separately
 - Fan Part No: X15FANKIT-ND
 - Fan socket details shown in section 3.4.17
- **BAT1 Li-ION BATTERY**
 - A Li-Ion battery can be installed on the X15 PCB
 - Battery Part Number: RENATA CR1220MFR FV
 - Can be purchased here:
<http://www.mouser.com/Search/Refine.aspx?Keyword=CR1220MFR>
 - **NOTE:** Before Installing Battery BAT1 remove R416 from bottom side of PCB



Figure 4. BAT1 Location

3.2.3 TOP Edge and Bottom Side

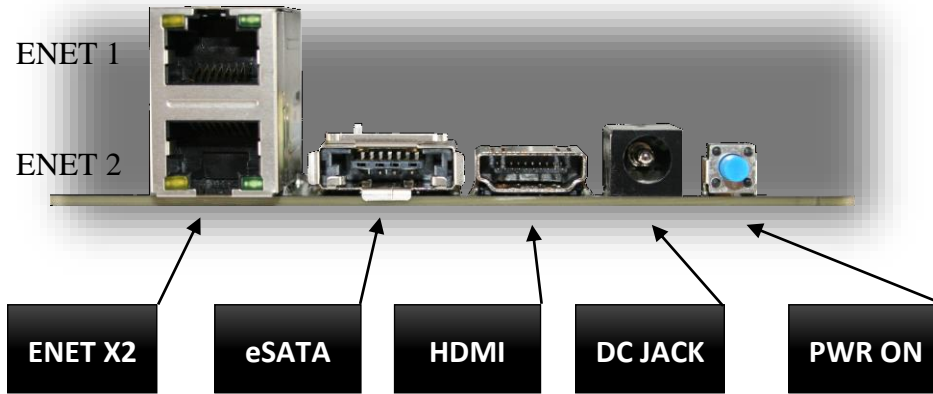

Figure 5. X15 Top Edge View

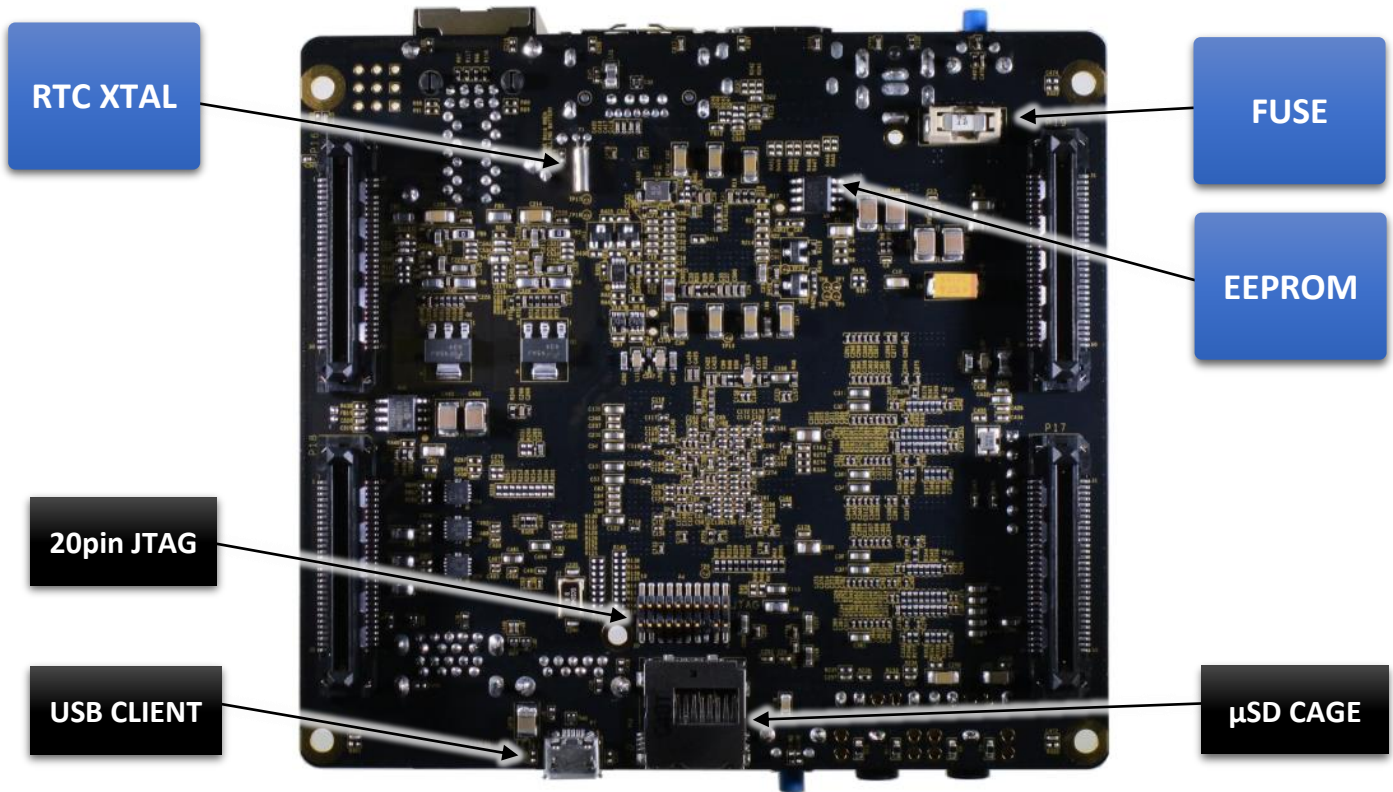

Figure 6. Bottom Side of X15

3.2.4 Bottom Side Details

Bottom Side Major Components Details

- **Y1** RTC Crystal
 - 32.768KHz REAL TIME CLOCK Tuning Fork Crystal
 - Used in conjunction with U6 and BAT1 (top side)
- **U8** EEPROM
 - 4KB EEPROM used to hold board information via I2C1
- **F1** 5A FUSE
 - 5A Fuse in SMT base
 - Replacement Fuse: 0454005.MR

Bottom Side Connector Details:

- **P4** 20-pin JTAG Connector
 - For use with TI JTAG emulators and CCS debugging tools

- **P7** USB Client
 - USB 2.0 Client port
 - USB Type B jack

- **P12** microSD cage
 - ALPS Push-Push Type – Reverse mounting – Micro SD Connector
 - Insert microSD card face up

3.2.5 Top Side Major Components

Figure 7 below shows the major IC and components on the BeagleBoard-X15.

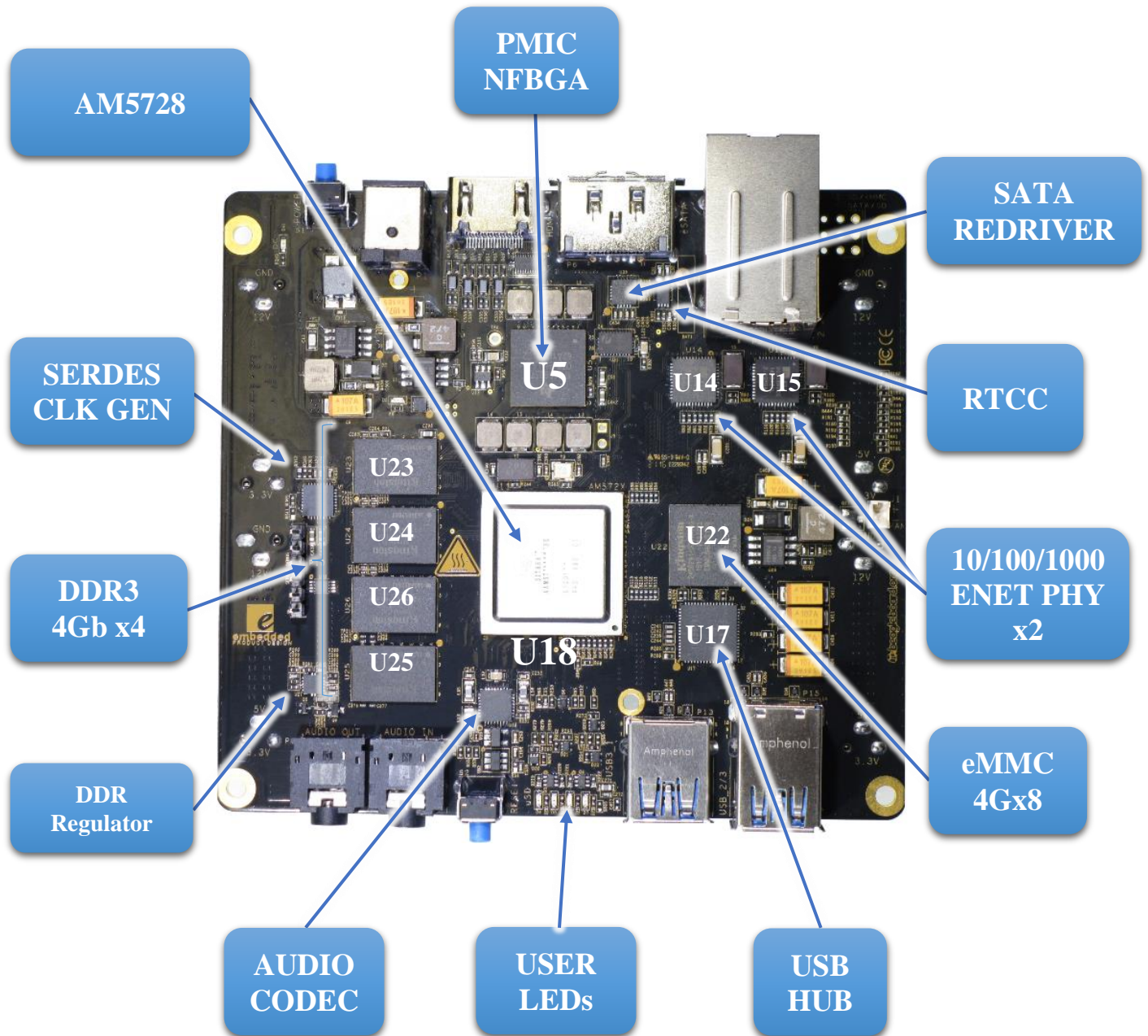

Figure 7. Location of Major ICs

3.2.6 Top Side Major Component Details

- **U5 PMIC**
 - Power Management IC (PMIC)
 - 13 x 13 nFBGA 0.8mm pitch
 - 7-configurable converters up to 6A output current
 - 7 LDOs for external use
 - 32KHz RC oscillator for power sequence
 - SPI or I2C control

- **U11 PROCESSOR**
 - Sitara AM5728, FCBGA 0.8mm pitch
 - Dual ARM Cortex-A15 @ 1.5GHz

- **U7 SERDES CLOCK GENERATOR**
 - Reference Clock generator for PCI Express (PCIe) Gen1-Gen3
 - Accepts 25MHz oscillator input

- **U23-U26 DDR3**
 - 4x 256Mb x16 DDR3L 2Gb (256MB)
 - 2x 32 bit memory buses with two 16 16b devices on each bus.

- **U27 DDR VTT REGULATOR**
 - TPS51200 Sink and Source DDR Termination Regulator
 - Lower Power DDR3 VTT Bus Termination

- **U18 AUDIO CODEC**
 - Low power stereo Audio DAC
 - Part No
 - 3D, EQ, PLL, LP Bypass, Notch Filtering

- **D4-D7 USER LEDs**
 - 4 user LEDs available
 - Part No: LTST-C191KFKT
 - GPIO Driven

- **U17 USB HUB**
 - 4-Port USB 3.0 HUB

- **U22 eMMC 4GB**
 - eMMC 5.0 (HS200) 153B 4GB
 - HS200 Standard

- **U14-U15 10/100/1000 ENET PHYs**
 - Single chip 10/100/1000Mbps ENET Transceiver

- RGMII3.3V/2.5V/1.8V tolerant IOs.
- **U6 RTCC**
 - 8pin RTC with optional battery backup
 - I2C I/F
- **U33 SATA REDRIVER**
 - 2 Ch 3-Gbps single lane redriver
 - Also supports SATA 1.5-Gbps
 - Hot Plug capable



3.3 CHECK IT OUT



This section provides instructions on how to check out the board after you receive it.

3.3.1 What is needed

Table shows the accessories needed to test all X15 peripherals. Some of these items may need to be purchased if the user does not already own them. For power supply and serial cables please observe power requirements when purchasing. The power jack on the BEAGLEBOARD-X15 accepts a 2.5mm barrel to differentiate it from other board supplies.

Table 2. List of Needed Accessories

<p>DC POWER SUPPLY</p> <ul style="list-style-type: none"> • 12V Supply • 60W (5A min) • 2.5mm x 5.5mm Barrel Plug Size • Option 1: TRG70A120 • Option 2: VEF65US12 • Option 3: CENB1060A1203F01 • Option 4: TRG70A120-02E01 	
<p>TTL TO USB SERIAL CABLE</p> <ul style="list-style-type: none"> • 3.3V USB to SERIAL • Compatible with the one used on BBB • Can be purchased from various sources • One such cable can be purchased here: http://www.digikey.com/product-detail/en/TTL-232R-3V3/768-1015-ND/1836393 	
<p>HDMI AUDIO-VIDEO CABLE</p> <ul style="list-style-type: none"> • Type A Male to Male • Full size cable – NOT as used for BeagleBone Black • Preferably 3ft or longer 	

<p>ETHERNET CABLE</p> <ul style="list-style-type: none"> • Two cables needed if both interfaces used • Use Cat6 cables • ENET PHYs have Auto MDI/MDI-x • Crossover or straight cables can be used 	
<p>AUDIO CABLE</p> <ul style="list-style-type: none"> • 3.5mm jacks on both ends • Need two if Speakers do not come with one 	
<p>SPEAKERS</p> <ul style="list-style-type: none"> • Any amplified desktop speaker system • Includes 3.5mm audio cable 	
<p>HDMI MONITOR</p> <ul style="list-style-type: none"> • HD monitor capable of 1080P • With integrated audio • Or Output jack for Audio 	
<p>MICRO SD CARD</p> <ul style="list-style-type: none"> • 4GB to 16GB • Class 10 • Standard Adapter 	
<p>eSATA ADAPTER CABLE</p> <ul style="list-style-type: none"> • eSATA to SATA cable • Combo cable • Below are two such cables: <p>http://www.cablesonline.com/19estosa22ex.html http://www.monoprice.com/product?p_id=8492</p>	

<p>SATA DRIVE</p> <ul style="list-style-type: none">• 2.5" SATA HDD - Hard Disk Drive <p>One option available here: Newegg.com</p> <ul style="list-style-type: none">• 2.5" SATA SSD - Solid State Drive <p>http://www.amazon.com/ADATA-Premier-2-5-Inch-Synchronous-ASP900S3-128GM-C/dp/B007RHT48S</p>	
<p>USB THUMB DRIVE</p> <ul style="list-style-type: none">• USB3.0 thumb drive• Needed for file storage• Or to boot from USB3	
<p>WIRELESS KEYBOARD/MOUSE</p> <ul style="list-style-type: none">• Wireless combo will save USB ports used• Less wire clutter	

Besides the accessories mentioned it is assumed the user has a PC or Laptop running Linux or Windows.

3.3.2 SETUP INSTRUCTIONS

Standalone w/Display and Keyboard/Mouse

In this configuration, the board works more like a PC, totally free from any connection to a PC as shown in **Figure 8**. It allows you to create your code to make the board do whatever you need it to do. It will however require certain common PC accessories. These accessories and instructions are described in the following section

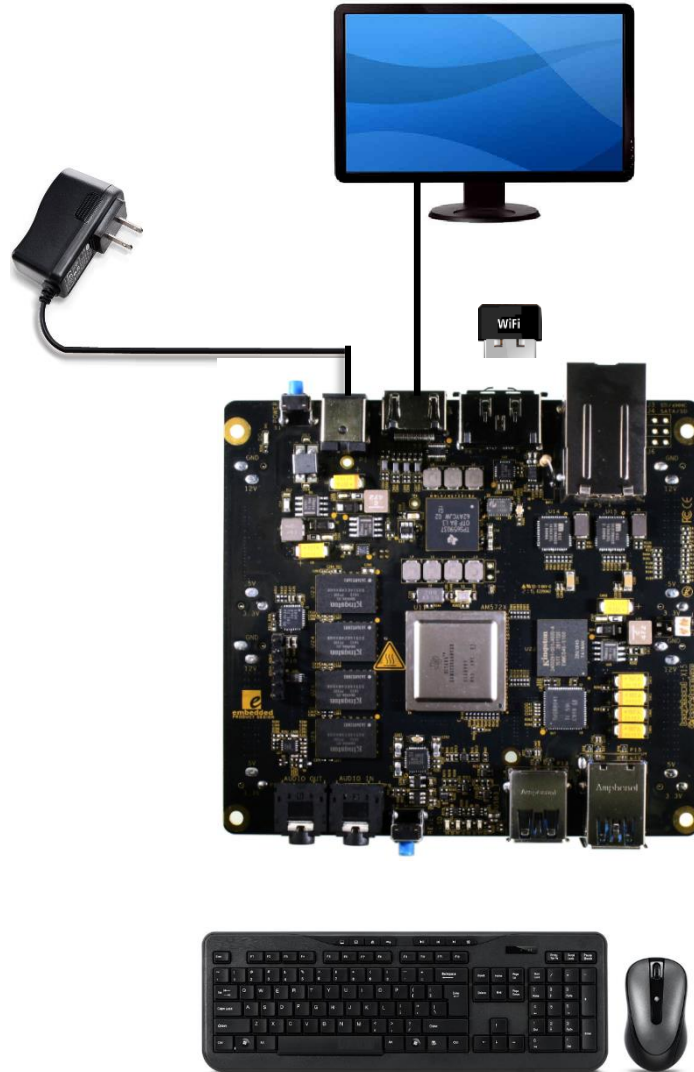

Figure 8. Desktop Configuration

Board is shown without the heatsink installed. Additionally, an Ethernet cable can be connected for network access if desired.

3.4 PLUG IN YOUR CABLES

3.4.1 ETHERNET

There are two ports on the Ethernet connector off the X15. Plug the cable into either port.

NOTE the orientation of cable insertion between the two ports in **Figure 9**.



Figure 9. Ethernet Ports

3.4.2 HDMI

Plug in HDMI cable into P11 HDMI connector on the top edge of the X15 board.



Figure 10. HDMI Ports

3.4.3 eSATA

Plug in the eSATA cable as shown in **Figure 10**. The same connector P6 can be used as a USB connector which is the 4th USB port on the X15.



Figure 11. eSATA/USB Port

3.4.4 Keyboard and Mouse

To avoid using up multiple USB ports a Wireless keyboard and mouse combination is preferred. The transceiver can be installed in any of the USB ports including P6 eSATA connector.

NOTE: USB 3.0 ports and devices have been shown to radiate radio-frequency noise that can interfere with some wireless or Bluetooth mice.

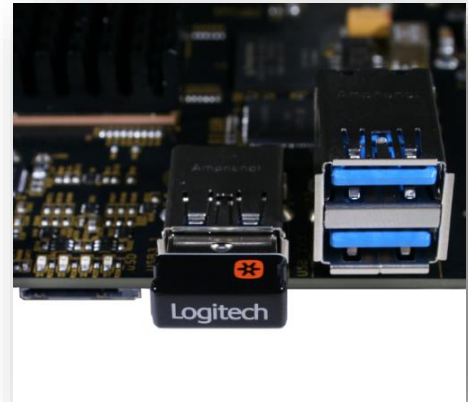

Figure 12. Keyboard Transmitter

3.4.5 AUDIO

To playback and record audio, insert speaker cable into Audio OUT jack of the X15 and an audio source into the Audio IN jack.

NOTE: Audio IN is not amplified. It is Line In only and does not support microphones.

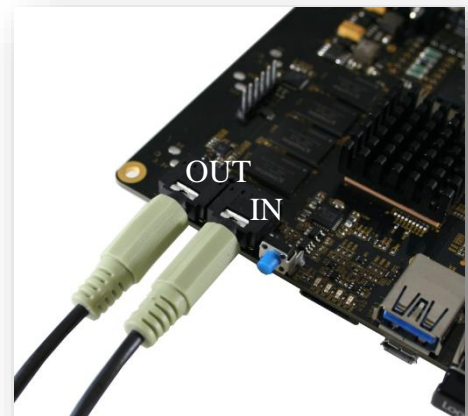

Figure 13. Audio Jacks

3.4.6 Micro SD Card

On the bottom edge of the X15 board, on the bottom side is the micro SD card cage. If booting from the SD card, the micro SD card is inserted as shown in **Figure 14** with the top side facing up.

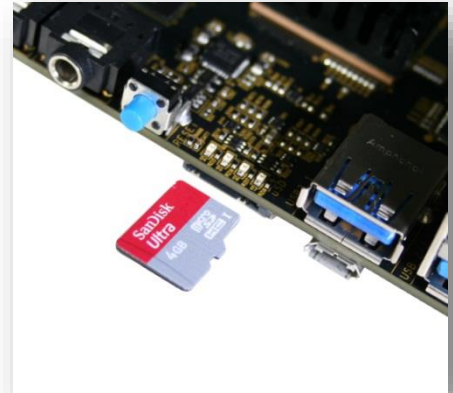

Figure 14. MicroSD Card Cage

3.4.7 USB Client

The USB Client connector P7 is located on the bottom side of the board below USB3 Port 1 and next to the uSD Card cage. Caution when inserting and removing the client cable as it will exert excessive pressure on the connector jack.

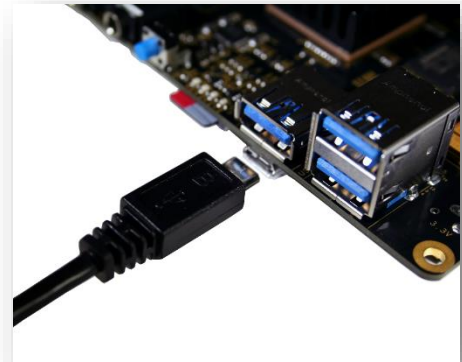

Figure 15. USB Client Connector

3.4.8 Serial Debug

Plug in the USB to Serial cable into the 6 pin header P10. Observe correct orientation. Pin1 is located at the top side of the header.

PIN NUMBER	SIGNAL
1	Ground
4	Receive
5	Transmit

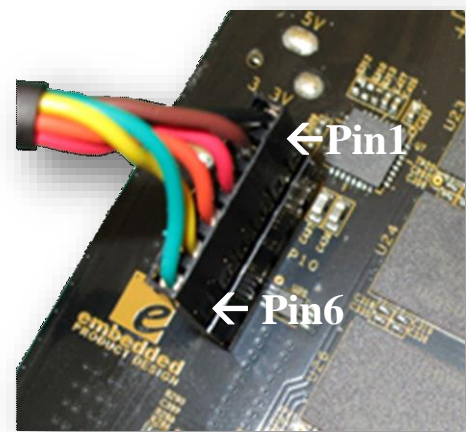

Figure 16. Serial Debug Port

3.4.9 Terminal Setup

Plug the USB end into your PC or Laptop and invoke MINICOM or TERATERM or your favorite Terminal emulator program.

The settings for serial communications are:

Baud rate:	115200
Data:	8 bit
Parity:	none
Stop:	1 bit
Flow control:	none

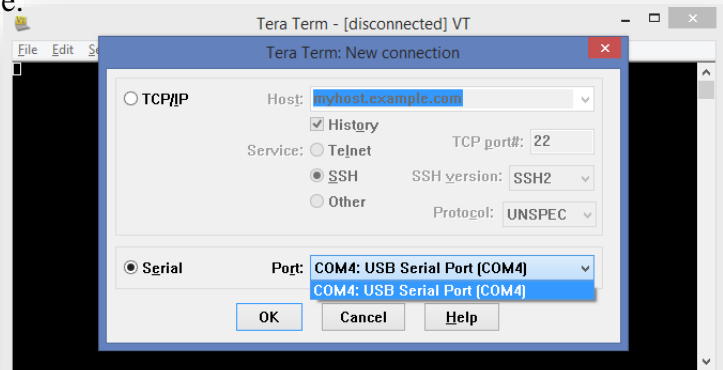

Figure 17. Terminal Window Setup

3.4.10 Plug in Power Cable

Once all the needed cables are inserted, plug in the DC power adapter into the P1 jack. This is a 2.5mm center contact and requires a supply that comes with a 2.5mm jack or an adapter to 2.5mm. See **Figure 18** for more info.



Figure 18. DC Jack Into P1

3.4.11 Power LEDS

Once the power plug is inserted in P1, the Power LED D41 will light up.

D41 - 12V Present LED

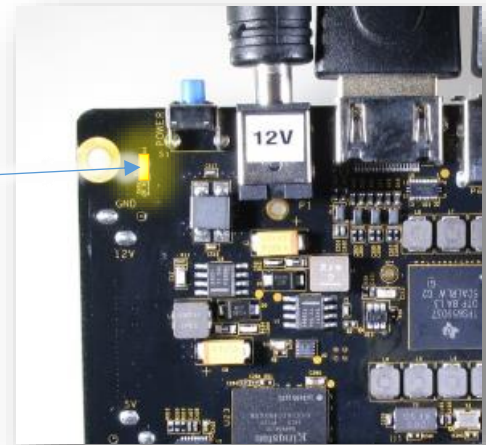

Figure 19. DC 12V LED

3.4.12 Turn ON HDMI monitor

Once power is connected, turn on the HDMI monitor. Change input to the HDMI port the X15 is connected to.



Figure 20. Monitor Power Button

3.4.13 Turn ON X15 Power

Though power is plugged in and the terminal is connected there will be no activity observed on the terminal. LED D41 will glow.

D41 - 12V Present LED

To turn ON the X15 main power press the blue momentary switch S1. This will cause LED D3 to glow showing that the board power is ON.

D3 - POWER ON LED

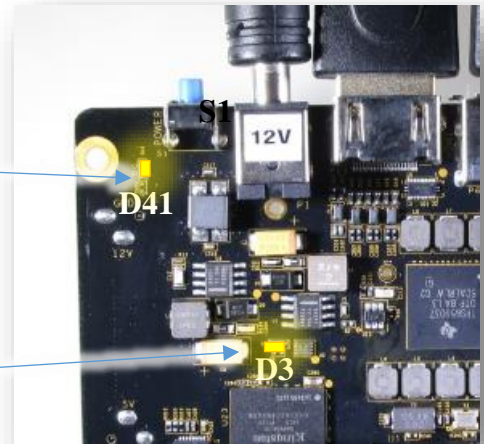

Figure 21. Power LEDs

3.4.14 User LEDs

The BB-X15 has four user LEDs for debug, and status indication. During the booting process the user may notice that the user LEDs will blink.

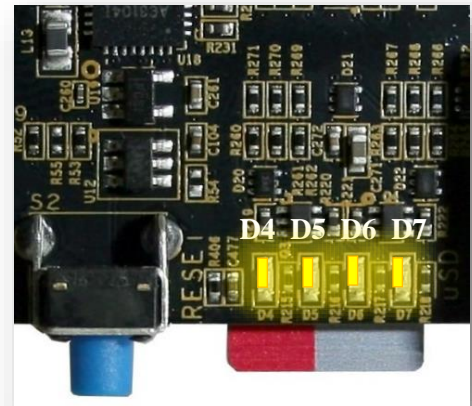

Figure 22. User LEDs

3.4.15 BOOTING

At this point the software present in eMMC or the SD card if installed will start to boot and activity can be seen on the terminal. The actual information printed out may vary based on the SW image used.

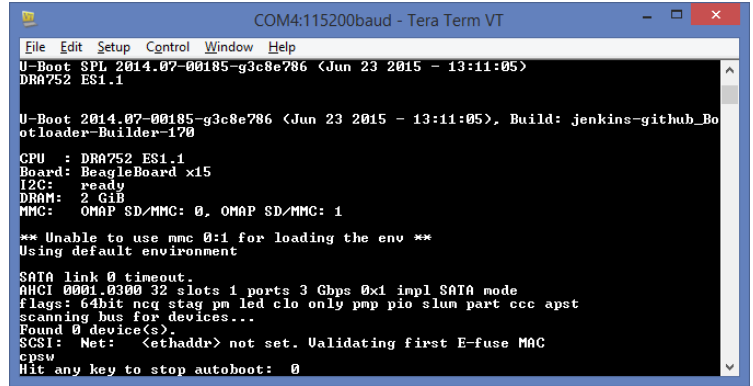
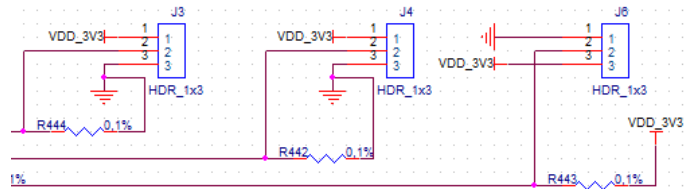

Figure 23. Terminal Window Showing Boot

3.4.16 Boot Strapping

The default option ,SD followed by eMMC setting, is hardwired via soldered on resistors. Table 3 shows the boot strap options for the BeagleBoard-X15. The default is SD then eMMC.

NOTE: To set different boot options Resistors R442-R444 will need to be de-soldered first and then solder in the other options. Be careful when doing this.



Boot Strap Options

		1-2	2-3
BOOT from SD then eMMC	J3		X
	J4		X
	J6		X
BOOT from UART	J3	X	
	J4	X	
	J6	X	
BOOT from SATA then SD	J3	X	
	J4		X
	J6		X

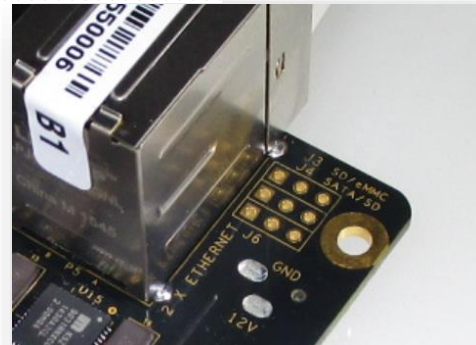

Figure 24. Boot Strap Resistors

3.4.17 FAN Connection

The X15 can support a 5V fan when a socket is installed at J1. Digikey offers a fan kit that will fit the X15 heatsink and plug into J1. Part number is [X15FANKIT-ND](#).

See **Figure 25** and the next section for one FAN option that is supported.

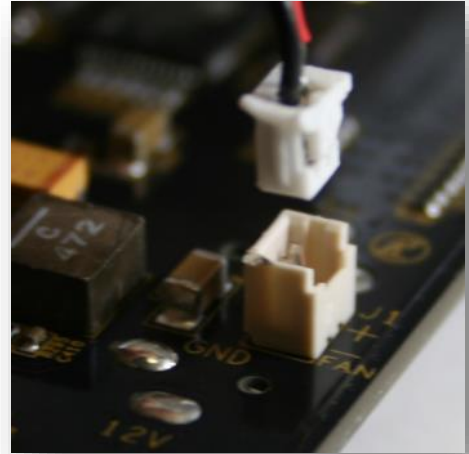

Figure 25. Fan Connector

3.4.18 FAN Mounting

The heatsink that comes with the X15 has a 7x7 fin matrix that can accept 4-40 self-threading screws at each corner. The screws will self-thread and hold the fan in place.

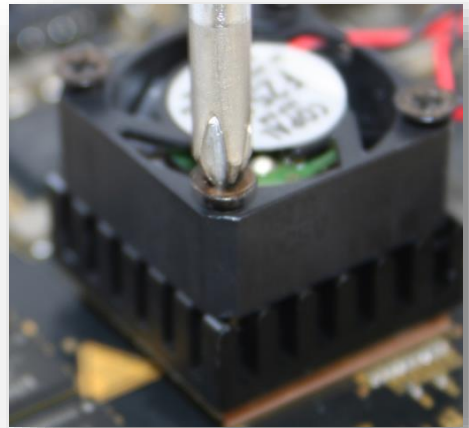

Figure 26. Fan Installation

3.5 TESTING

Once the X15 interfaces are connected your system is ready to test. This section will go through what you can quickly test on your new BB-X15

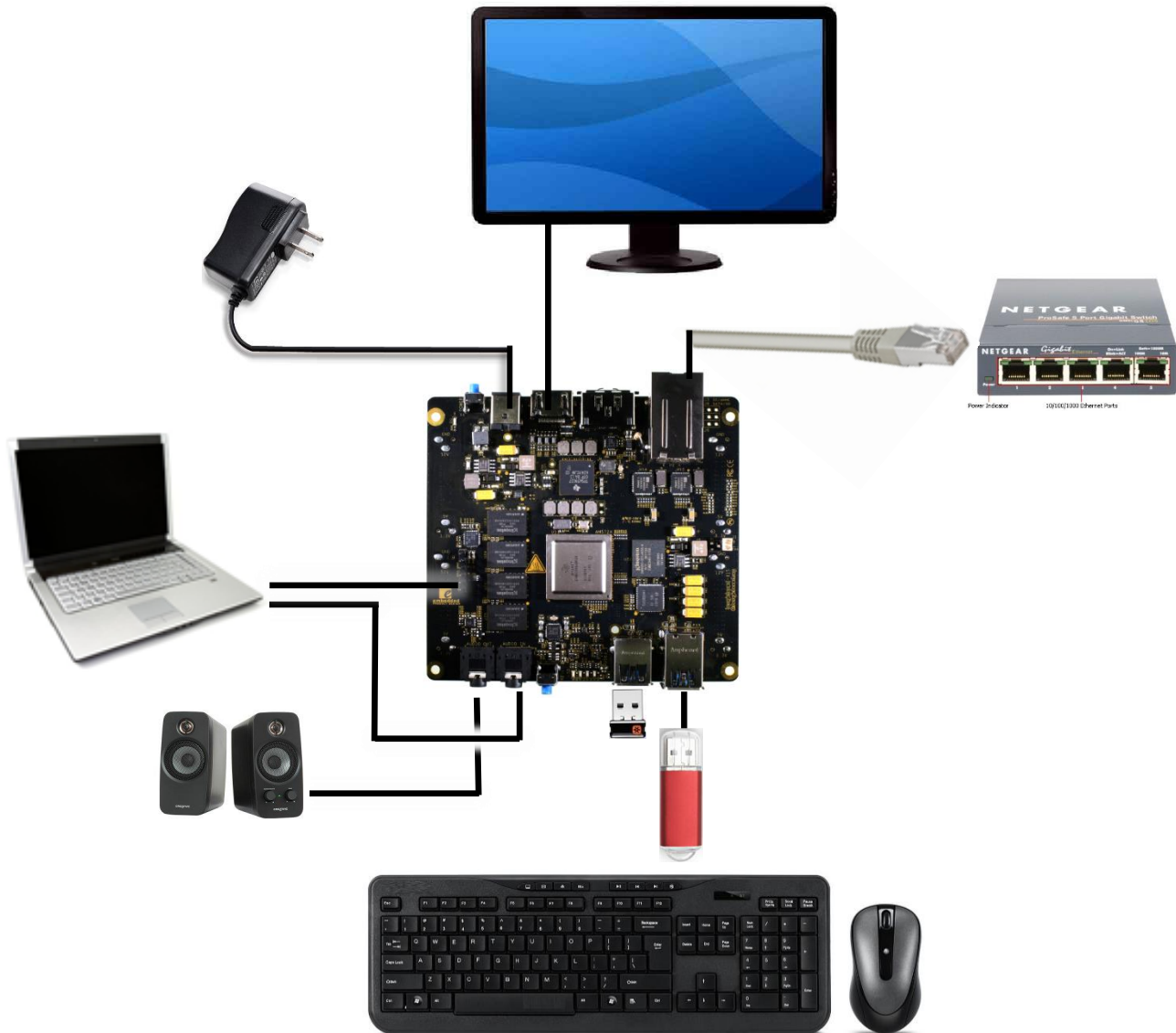

Figure 27. X15 test Setup

Using a wireless keyboard and mouse is preferred since it frees up USB ports. However, when using a wireless combo, please know that USB 3.0 ports and devices have been shown to radiate radio-frequency noise that can interfere with wireless mice

that rely on 2.4GHz radio-frequency dongles, as well as mice that use Bluetooth for connectivity. This is a common warning you see particular on laptops.

3.5.1 DEBUG

The Serial debug port on the processor is UART3 via a single 1x6 pin header. In order to use the interface a USB to TTL adapter will be required. The header is compatible with the one provided by FTDI and can be purchased from various sources. Signals supported are TX and RX. None of the handshake signals are supported. On the PC you will see activity that will take you to login prompt.

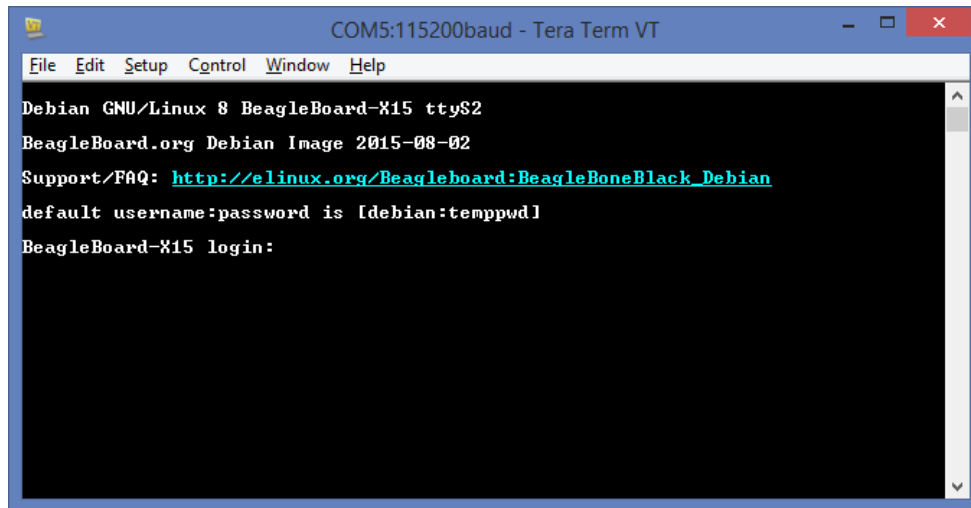

Figure 28. Terminal Window

A few seconds after the board power is turned on, the image in eMMC or SD if booting from SD, will boot and the Debian desktop will soon show up on the HDMI monitor.

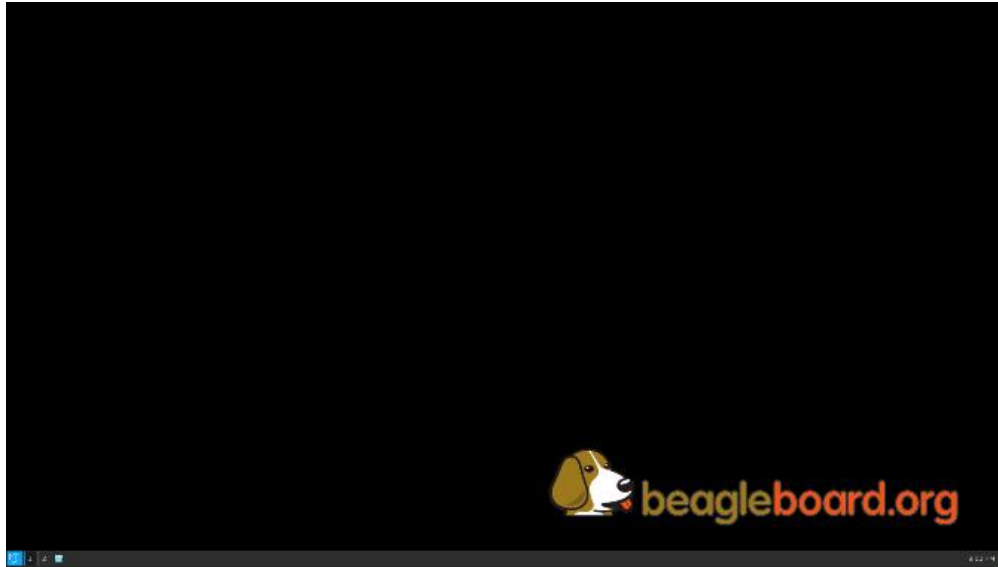

Figure 29. Debian Desktop

3.5.2 ETHERNET

Assuming the Ethernet cable is connected to one of the Ethernet ports on the Beagleboard-X15 a quick test can be performed by pointing the mouse to the bottom left corner of the Desktop and clicking the Debian menu logo. From here point to Internet → Chromium Browser.

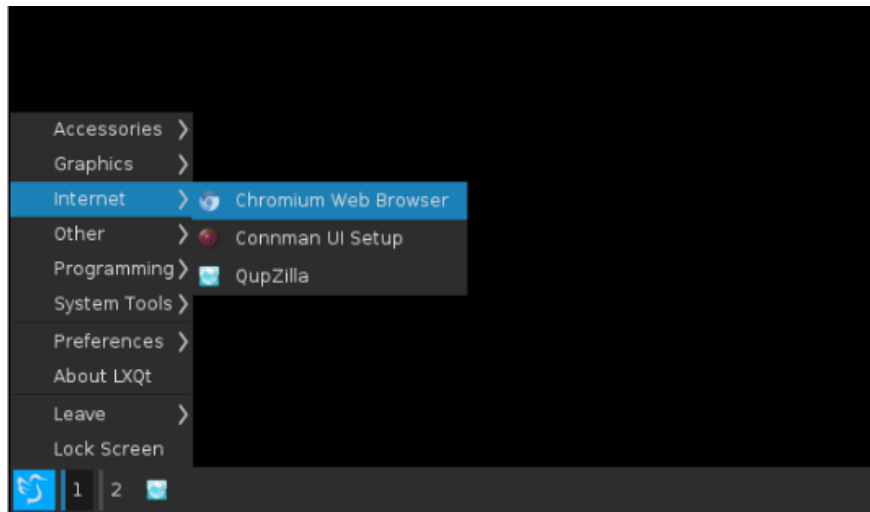

Figure 30. Open Web Browser

The browser window will open and if there is an internet connection, the browser will go to the default homepage.

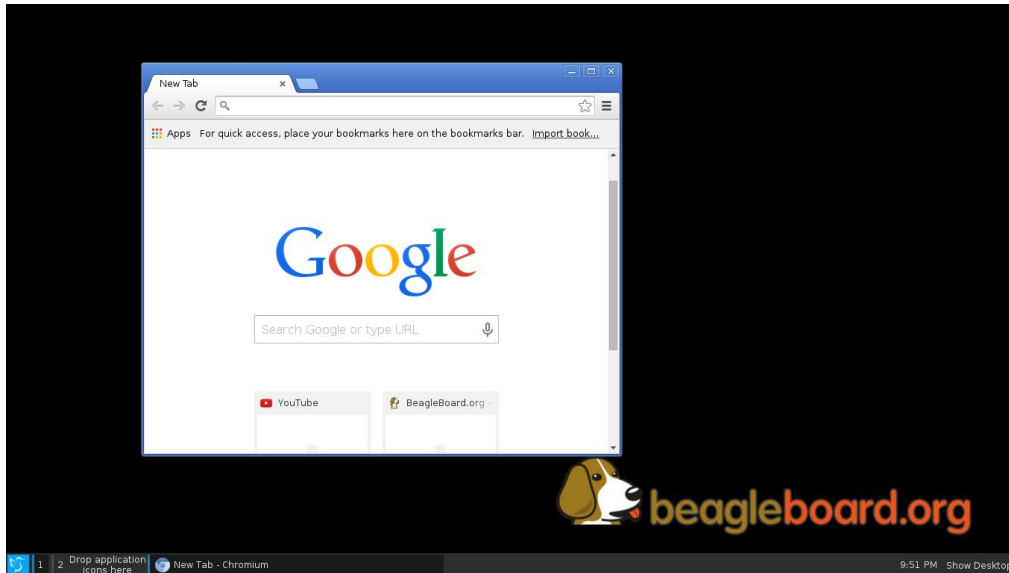

Figure 31. Default Home Page

The second Ethernet port can be similarly tested by moving the cable from ENET0 to ENET1. See **Section 3.4.1**

3.5.3 SPEAKERS

To test the sound of your X15 you can open a sound file and play it back. In the example below, a simple file is played via the Chromium Web browser. The sound file can be present in a USB flash drive plugged into one of the USB3/2 connectors at the bottom edge of the board or you could copy a file onto the X15 eMMC .



Figure 32. Insert USB Flash Drive

NOTE: Depending on the width of the flash drive used, two adjacent drives may not fit well in P13 Port-1 and P15 Port-2 connectors due to the proximity of the two connectors. If two drives will not fit, do not force but use a narrower flash drive in one of the bottom ports.

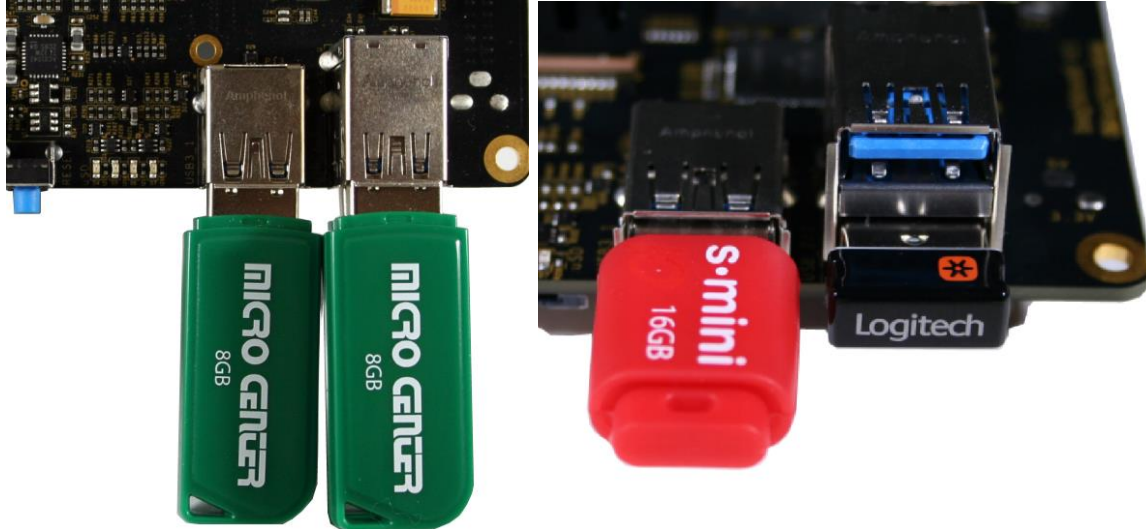

Figure 33. Adjacent USB Devices

On the Debian Desktop a window will pop-open and ask you if you want to see the contents of the newly installed flash drive. Also on the Tera Term console you can also read the logs associated with the insertion of the drive.

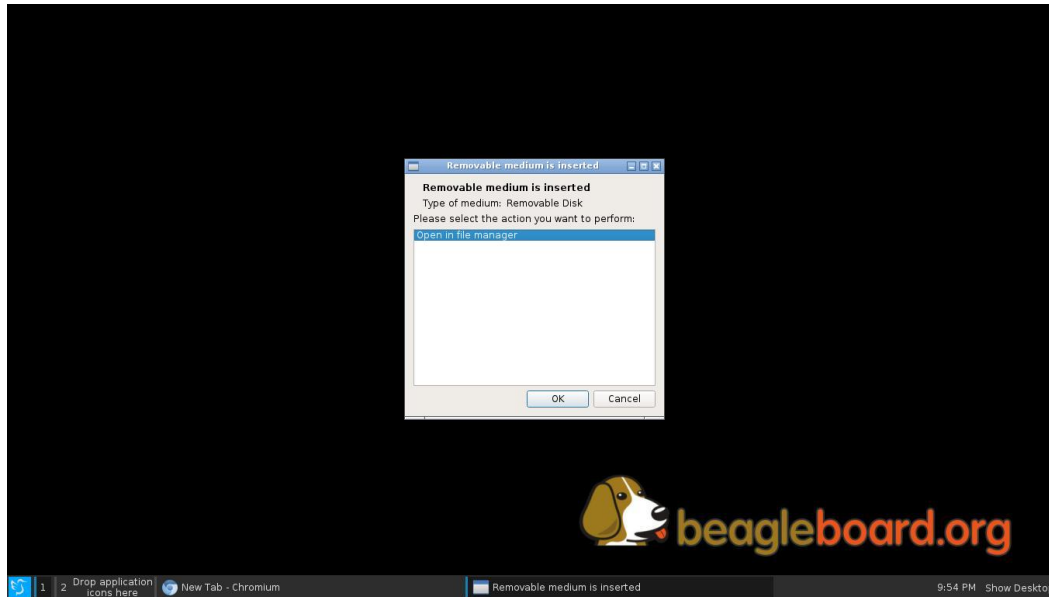

Figure 34. Media Insertion Notice

Click 'Open in file Manager' to see the contents of the flash drive. Proceed to open the sound file. In case there is no music player installed yet, open the wav file with Chromium Brower. Then click play.

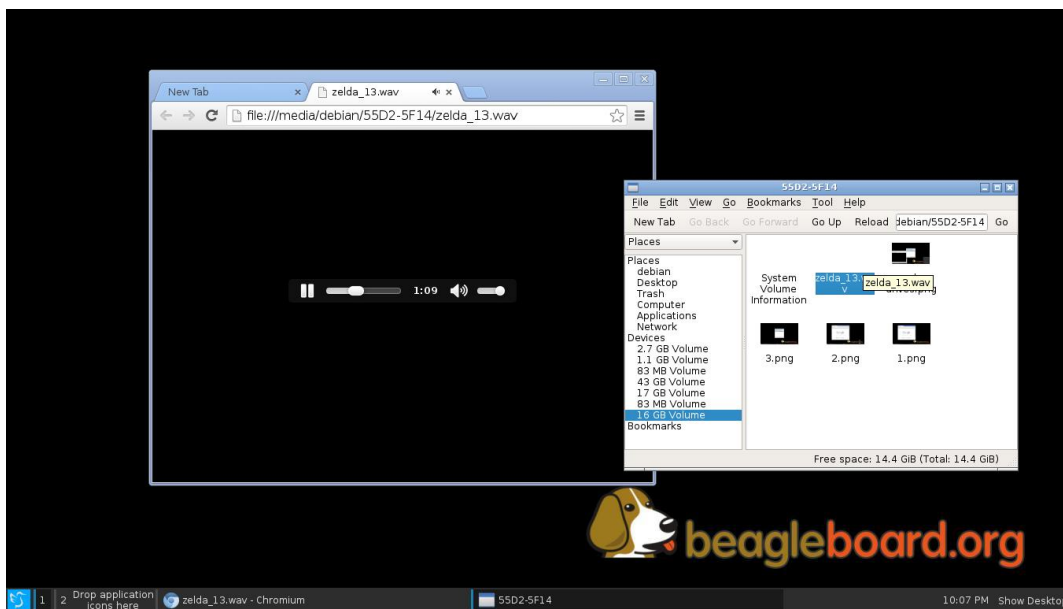

Figure 35. Open And Play Sound File

To adjust volume make sure your speakers are connected and the speaker volume is turned to a nominal volume. The X15 volume can be adjusted by clicking on the lower

right hand side left of the clock (icon missing in this example) and adjusting the volume lever up and down.

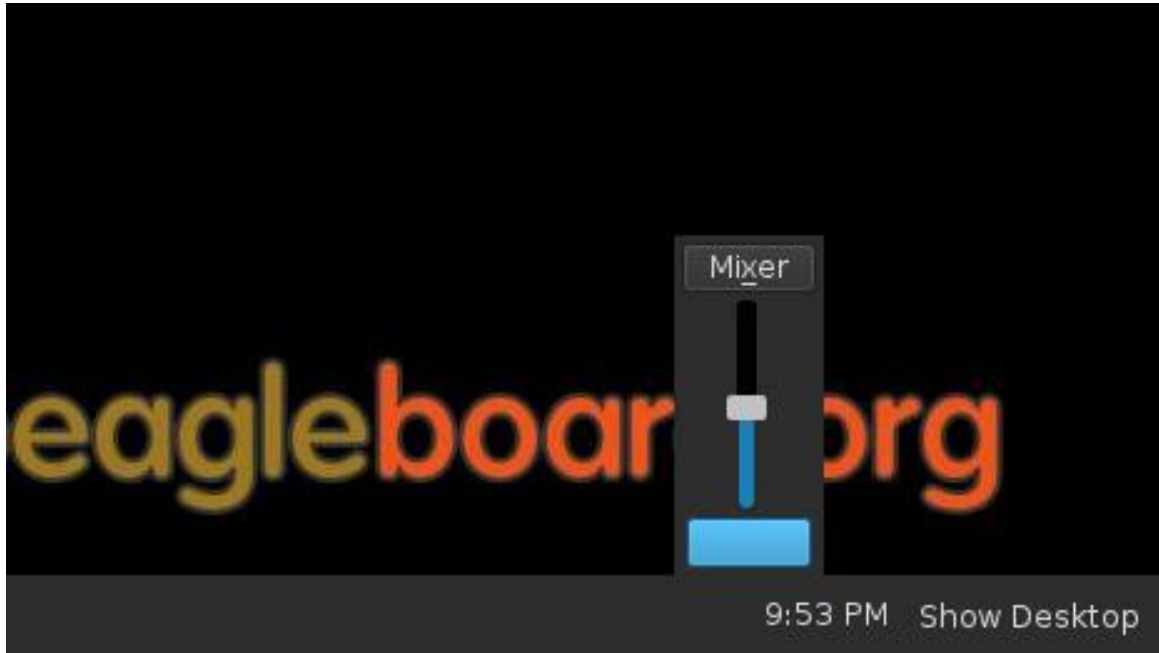

Figure 36. Volume Adjust

Audio In can be similarly tested by using a 3.5mm to 3.5mm audio cable between a PC playing a sound file and the X15 recording it via connector jack P9.

3.5.4 eSATA

To test the eSATA interface you will need a cable and drive as described in **Section 3.4.3**. This drive has to be 2.5" drive since this interface will only support 3.3V drives. Simply plug in the cable into connector P6 and the drive will be detected. The connector also accepts a USB 2.0 flash drive or other USB 2.0 devices.



Figure 37. eSATA Cable and Drive

When plugged in, the eSATA or USB will be listed on the Debian Desktop as shown below:

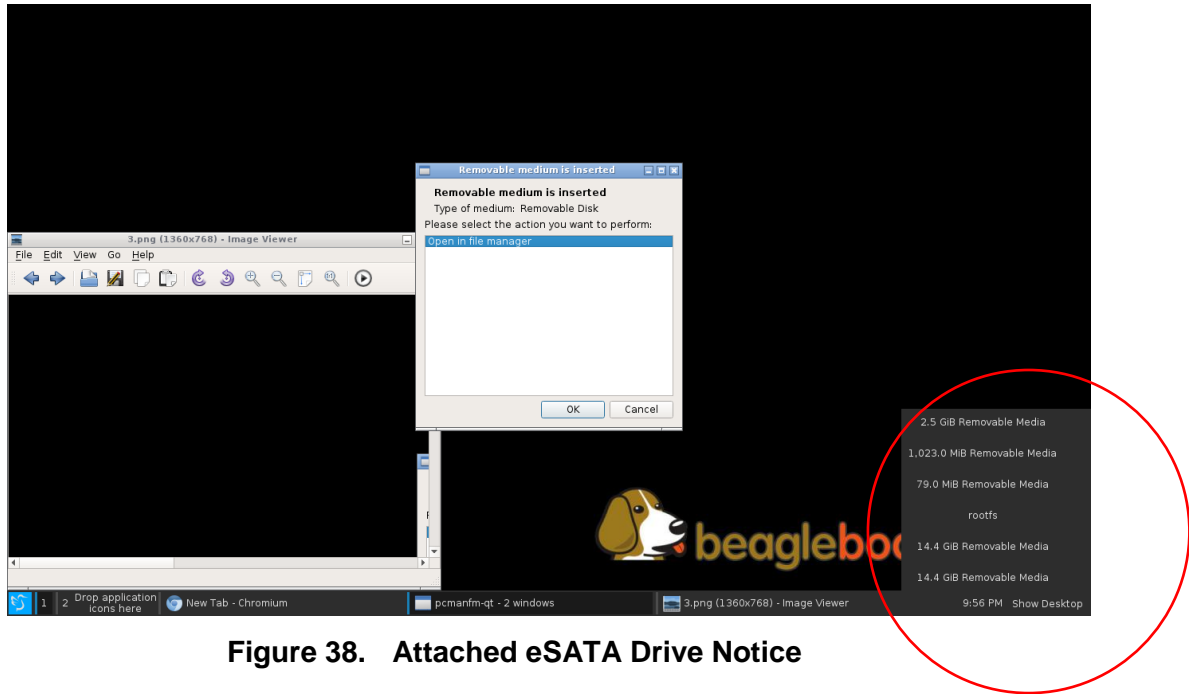

Figure 38. Attached eSATA Drive Notice

3.5.5 POWER ON and RESET

To power OFF the board you can Press-and-Hold the power button for 12 seconds. Another way to power off the board is to use the **'shutdown'** command at the terminal prompt. The board will then start powering off.

```
COM5:115200baud - Tera Term VT
File Edit Setup Control Window Help
Unmounting /run/user/1000...
Unmounting /sys/kernel/debug...
[ OK ] Stopped Load/Save Random Seed.
[ OK ] Unmounted /media/debian/55D2-50264.
[ OK ] Unmounted /media/debian/55D2-50263.
[ OK ] Unmounted /media/debian/55D2-50262.
[ OK ] Unmounted /run/user/1000.
[ OK ] Unmounted /sys/kernel/debug.
[ OK ] Reached target Unmount All Filesystems.
[ OK ] Stopped target Local File Systems (Pre).
Stopping Create Static Device Nodes in /dev...
[ OK ] Stopped Create Static Device Nodes in /dev.
Stopping Remount Root and Kernel File Systems...
[ OK ] Stopped Remount Root and Kernel File Systems.
[ OK ] Reached target Shutdown.
[ OK ] Reached target Final Step.
Starting Power-Off...

Broadcast message from root@BeagleBoard-X15 (Thu 2015-08-27 23:32:26 UTC):
The system is going down for power-off NOW!
[ 222.644810] reboot: Power down
```

Figure 39. Powering Off Using Shutdown Command

To **RESET** the board you can press the RESET button S2. Pressing once should reboot the board.



Figure 40. Reset Button S2

3.5.6 HIGH TEMP CAUTION



CAUTION: *The BeagleBoardX15 may reach elevated temperatures. Avoid handling the board while power is applied, especially in area shown below. The same is true for the bottom side of the board.*

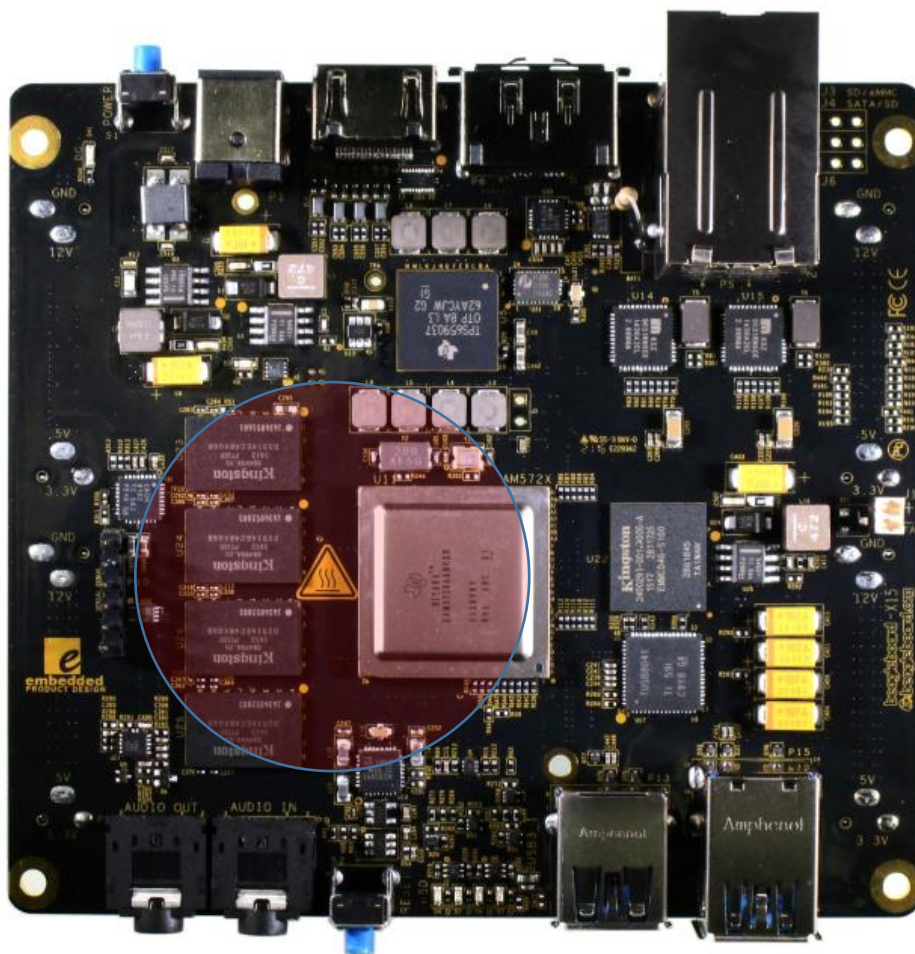

Figure 41. X15 Heat Zone

4.0 Hardware Design Overview

This section provides a more detailed description of the design of the board. This is intended to provide a more complete description of each circuit. It is intended to provide basic knowledge of the devices used and how they interface to one another. It does not provide details of their designs or specification. Please refer to the datasheet for each device from their respective suppliers if this information is needed.

4.1 Features

The Table 2 below provides the high level features of the BeagleBoard-X15.

Table 3. BeagleBoard –X15 Features

	BeagleBoard-X15
Processor	Dual ARM Cortex-A15 @ 1.5GHz, TI Sitara AM5728
Graphics	Dual Core SGX544 3D, 532MHZ
DSP	Dual C66x, 700MHZ
Video Accelerator	IVA, 532MHZ
Graphics	GC3230 2D BTBLT
GP ARM Cores	DUAL ARM M4, 212MHZ
SDRAM	2GB DDR3L, Dual 32bit bus, Non-ECC 533MHZ
Onboard Flash	4GB, 8bit Embedded eMMC
PMIC	TPS659037
Debug Support	20-pin CTI JTAG, Serial debug header
PCB	4.2" x 4", 12 layers
Indicators	(2) Power, (4) Ethernet, (4) User Controllable
HS USB 3.0 Host	(2) Type A 900ma (1) 1800mA (1)
USB 2.0 Host	(1) 500mA via eSATA Connector
USB 2.0 Client	(1) micro USB Type B
Ethernet	(2) 10/100/1000 RJ4
SATA	(1) eSATA Connector- Powered 500mA
LCD Ports	(2) Via Expansion
PCIe	(2) Channels via expansion
Camera Ports	(1) Via expansion
SD	(1) microSD
User Input	(1) Reset Button (1) Power Button
HDMI	(1) Full Size connector, 24b 1920x1080 60FPS, EDID
Audio	HDMI and AIC3104 (Stereo In/Out)
Expansion	(4) 60 pin dual row headers
GPIO pins	157
UARTs	7
SPI/I2C/CAN	1/1/1
PRU Pins	185
Real Time Clock	8pin RTC with optional battery backup, I2C I/F
Current Taps	(4) 5V, 3.3V, VDD_MPU, VDD_DSP, VDD_CORE
Weight	TBD
Power	12VDC@2A (3A additional if USB3 ports fully loaded)

4.2 Block Diagram

The figure below is a block diagram of the board. There are more detailed block diagrams in some of the sections that follow along with condensed schematics for the various circuits.

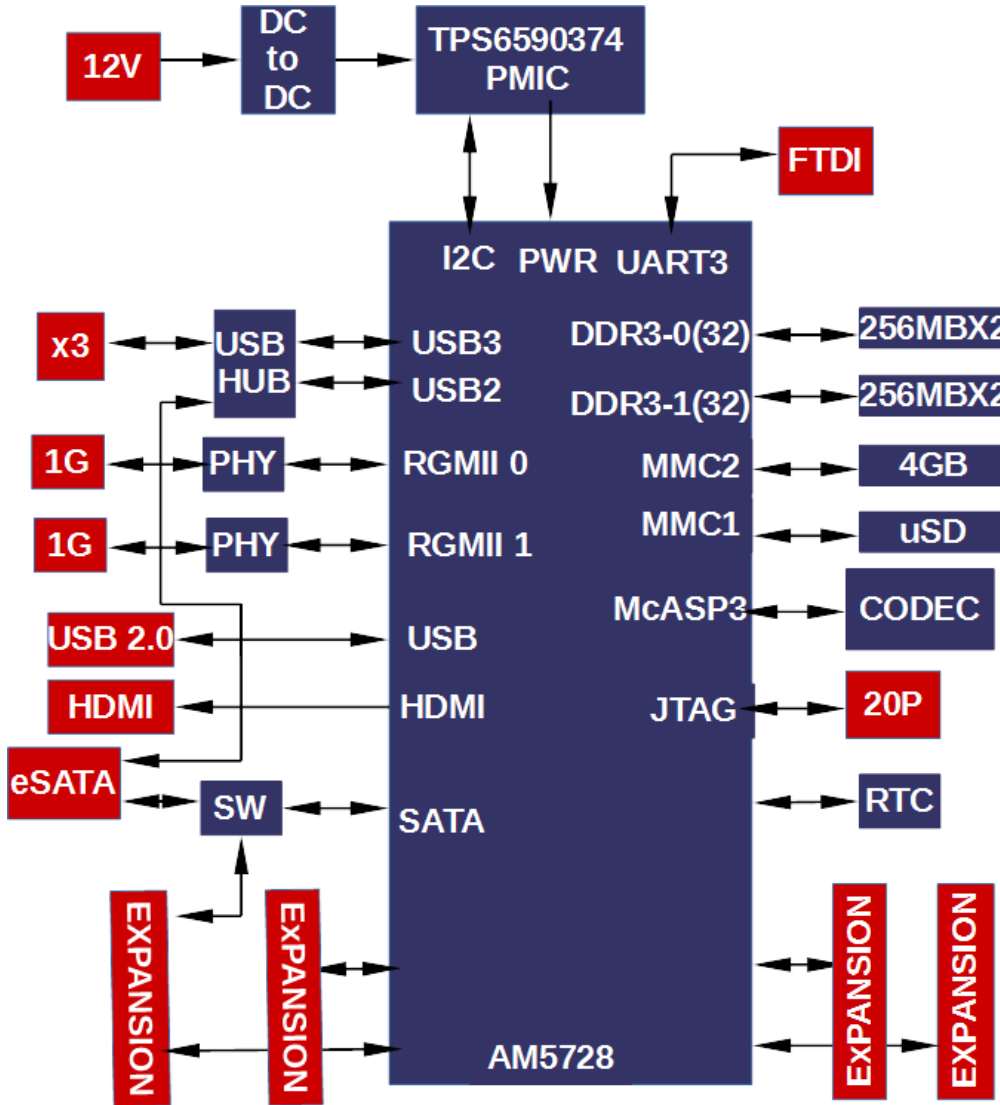

Figure 42. System Block Diagram

4.3 Power Subsystem

Figure 17 is the high level block diagram of the system power architecture of the board.

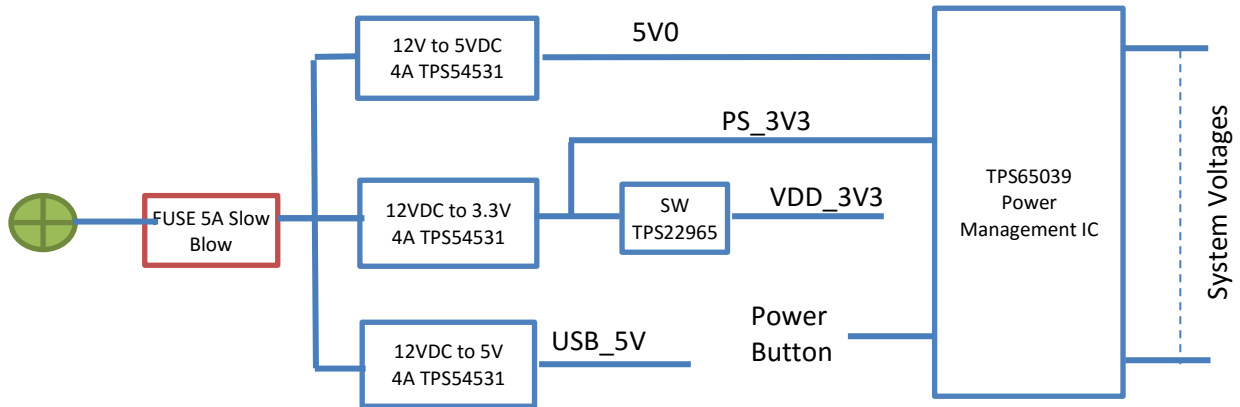

Figure 43. System Power Management Block Diagram

4.3.1 Input Power and Conditioning

The board is powered from a 12V 5A power supply using a 2.5mm x 5.5mm connector.

There are three switching regulators that are used to create the four main voltage rails required by the system.

- **5V0**.....Provides 5V to the PMIC, LEDs, HDMI, and the expansion headers.
- **PS3V3**.....Provides the main 3.3V I/O rail supply, via the SW, and to the PMIC.
- **VDD_3V3**....Provides main I/O rail for the board and the expansion headers. This is controlled by a power FET.
- **USB 5V**.....The USB requires a lot of current to meet the USB3 requirements. This switcher is dedicated to supplying the power to the USB3 ports.

There is a fuse provided to limit the current to the 5A rating of the power supply. The fuse is replaceable.

4.3.2 PMIC

The figure below is the high level block diagram of the TPS659039-Q1 Power management IC used on the board.

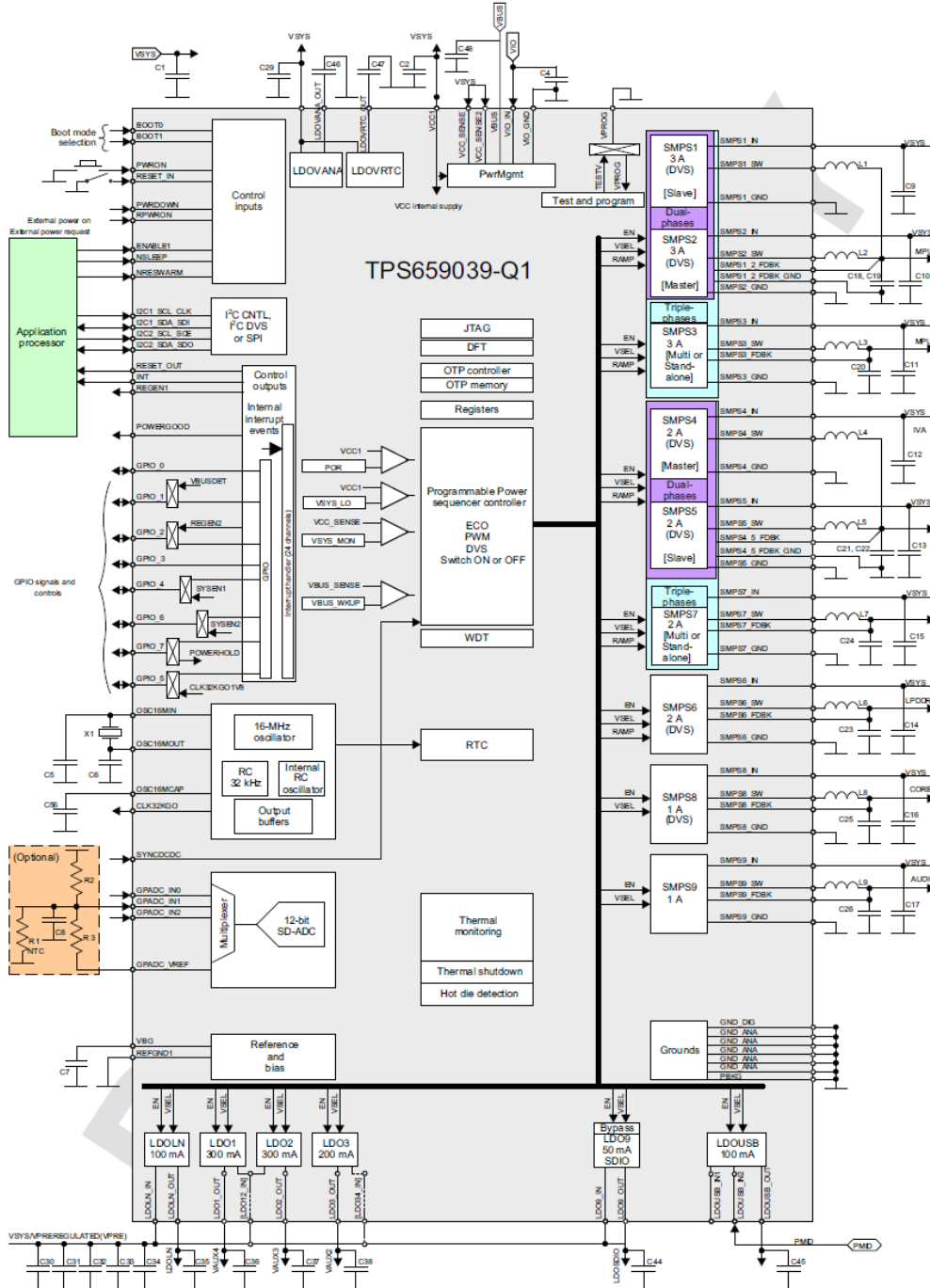

Figure 44. TPS650374 Block Diagram

The PMIC has multiple switchers and LDOs that provide power to the processors and the overall system. The one exception to this is the VDD_3V3 rail that is used to power the I/O rails of the processor and the other devices in the system. This rail is controlled by the TPS65039 to insure proper power sequencing. The table below shows the distribution of the various rails and the sequence in which they come up.

Table 4. Power, Current, Sequencing and Distribution

SEQ	SIGNAL	VOLTS	mA	DELAY	PMIC RAIL	MODE		AM57X
						ON	SLEEP	
1	LDO_VRTC	1.8V	250	0	LDOVRTC	ON	ON	vdda_rtc
2	VDD_1V8	1.8V	1000	550	SMPS8	Forced PWM	OFF	vdds_mlbp
								vdds18v
								vdds18v_dds1
								vdds18v_dds2
3	VDD_RTC	1.05V	50	0	LDO9	ON	ON	vdd_rtc
4	VDDA_1V8_PLL	1.8V	100	550	LDOLN	ON	OFF	vdda_abe_per
								vdda_ddr
								vdda_debug
								vdda_dsp_eve
								vdda_gmac_core
								vdda_gpu
								vdda_iva
								vdda_video
								vdda_mpu
								vdda_osc
5	VDD_CORE	1.03V	2000	550	SMPS6	Forced PWM	OFF	vdd
6	VDD_MPU	1.09V	6000	550	SMPS1&2	Forced PWM	OFF	vdd_mpu
7	VDD_DSP	1.06V	4000	550	SMPS4&5	Forced PWM	OFF	vdd_dspeve
								vdd_gpu
								vdd_iva
8	VDDA_1V8_PHY	1.8V	200	0	LDO3	ON	OFF	vdda_usb1
								vdda_usb2
								vdda_hdmi
								vdda_pcie
								vdda_pcie0
								vdda_pcie1
								vdda_sata
								vdda_usb3
9	VDD_SHV5	3.3V	300	550	LDO2	ON	ON	vddshv5
10	VDD_3V3	3.3V		550	REGEN1 (TPS54531D via TPS22965 switch)	ON	OFF	vddshv1
								vddshv10
								vddshv11
								vddshv2
								vddshv3
								vddshv4
								vddshv6
								vddshv7
								vddshv9
								vddshv12
11	VDD_DDR	1.35V	2000	550	SMPS3	ON	OFF	vdds_dds2
					TPS51200	ON	OFF	vdds_dds1
12	VUSB_3V3	3.3V	100	0	LDOUSB	ON	OFF	ddr1_vref0
								ddr2_vref0
								vdda33v_usb1
13	VDD_SD	3.3V	300	550	LDO1	ON	OFF	vdda33v_usb2
								vddshv8
14		RESET_OUT				ON	OFF	

In order for the board to power on, you will need to press the power button one time. Press and release and do not hold the button down.

4.3.3 Indicators

There are two orange indicators on the board for the power rails:

- DC...indicates that the 12V DC supply is connected. It does not indicate that the voltage is within specification, but only that it is connected.
- POWER...indicates that the PMIC has powered on and that the voltages are then applied to the board. It does not indicate that any voltages are within specification, but only that it is connected.

4.3.4 Voltage Clamp Circuits

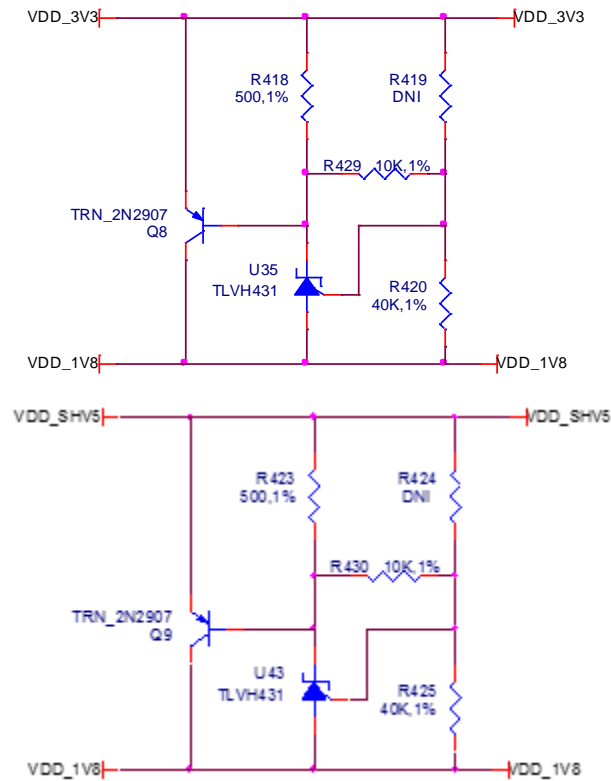

Figure 45. Voltage Clamps

During power down it should be ensured that the difference between VDD_{DS} and VDD_{SHVx} [1–6] during the entire power-down sequence is < 2 V. If this is violated it can result in reliability risks for the processor.

This solution was added to make sure that the difference between the 3.3-V VDDSHVx rails and the 1.8-V VDDS rail never exceeds 2V.

4.3.5 USB Power Bus

The board is designed with a USB 3.0 HUB and supports three USB 3.0 ports. The requirement is that each port support up to 900mA per port. For a high current charging port, this number is raised to 1.5A. This brings the total to 3.3A max of 5V. In order to supply this much current if needed, a dedicated 5V switcher is supplied. The figure below shows the switcher.

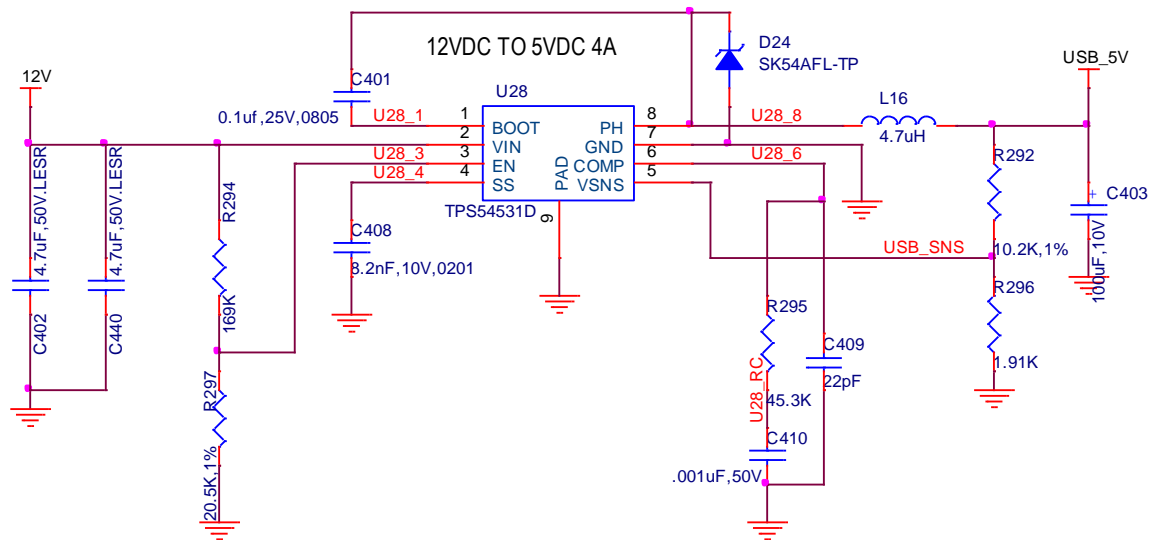

Figure 46. USB 5V Switcher

The switcher is capable of supplying up to 4A. It is not expected to reach that much, but the capacity is provided. In the event that it is required to compensate for onboard voltage drop, the voltage level can be adjusted by changing R292 and R296 as indicated in the datasheet for the switcher. The need for this is not expected, but a user may want to create a little higher voltage to compensate for devices connected to the ports.

4.4 AM5728 Processor

This board is designed to support the AM5728 processor. For detailed information on the AM5728 processor you can go to <http://www.ti.com/product/AM5728/compare> for more information. **Figure 47** is the block diagram of the AM5728 processor.

Sitara™ AM572x Processors

Benefits

- Sitara's highest performance ARM® devices w/DSP accelerators
- 10,500 ARM Cortex®-A15 DMIPS
- Upgraded graphics performance with HD Video support

Sample Applications

- Human Machine Interface (HMI)
- Industrial PC
- Digital Signage
- Medical Imaging

Key Features

- Dual 1.5GHz Cortex-A15s, 213MHz M4s, and 750MHz C66x DSPs
- 1080p Video Decoder/Encode
- 3D (x2) and 2D acceleration
- Multiple Video Input Ports
- Display Subsystem
- Quad core Programmable Real-time Unit (PRU)/Industrial Communications Subsystem
- USB3, PCIe, SATA

Package: 23x23, 760 pin, 0.8mm

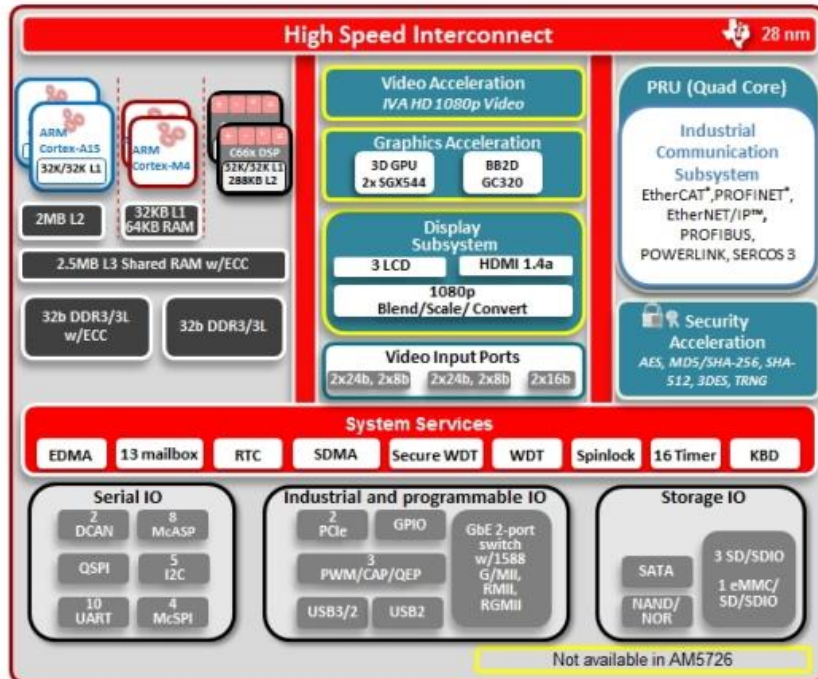

 TEXAS INSTRUMENTS

Figure 47. AM5728 Block Diagram

4.5 Memory Block Diagram

Figure 48 below shows the block diagram of the memory system on the board.

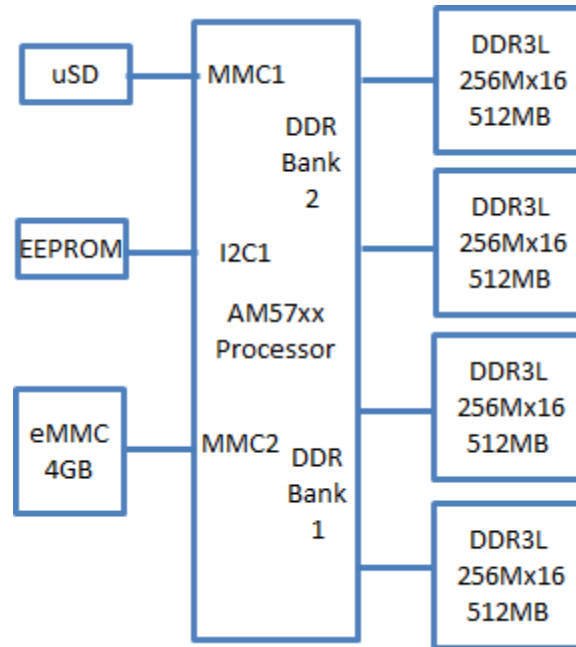

Figure 48. System Memory Block Diagram

- uSDThe SD card cage that supports booting for the processor
- EEPROM...provides board identification information
- eMMC....provides boot source for the processor
- DDR3L...main program space from which the processor operates.

Each of these are discussed in their own sections to follow.

4.6 DDR3L

There are four 256Mb x16 DDR3L 2Gb (256MB) memory devices used in the design. The memory used is either the MT41K256M16HA-125:E from Micron or the D2516EC4BXGGB from Kingston. There are two 32 bit memory buses with two devices on each bus.

4.6.1 DDR3 Terminations Regulator

Figure 22 below is the regulator that handles the VTT voltage rail. The regulator creates the voltage for the termination circuits and the DDR_VREF level as well.

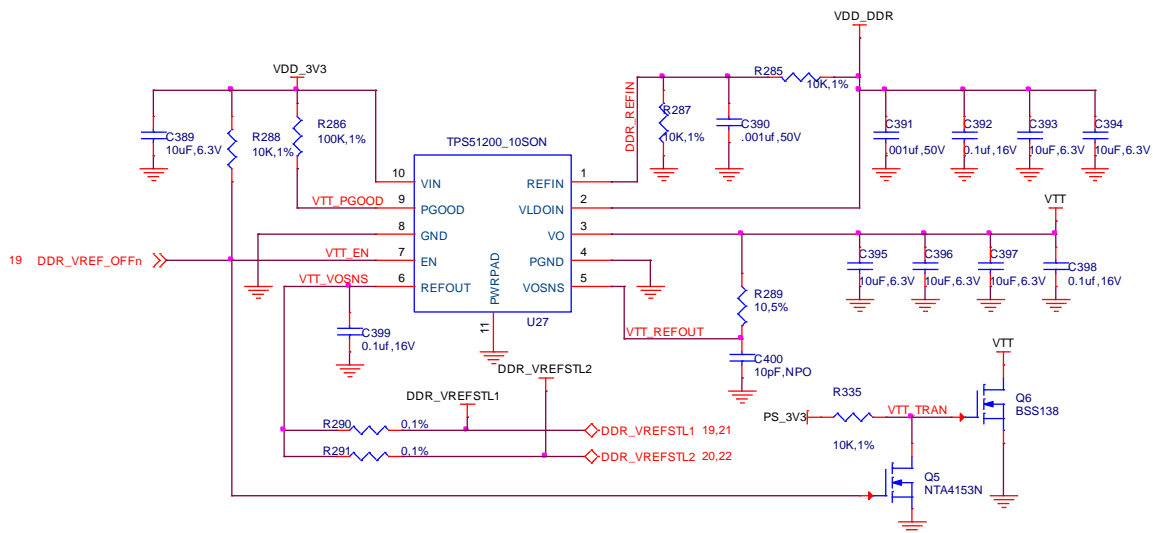

Figure 49. DDR3 Termination Voltages

This regulator supplies the required functions for both of the DDR3L banks on the board. Q5 and Q6 are added to force a drain off of the VTT voltage after powering off the system to bleed off any residual voltage left on that pin in order to prevent damage to the processor.

4.6.2 DDR3 Terminations Resistors

The figure below is the terminations on the control lines of the DDR3 interface. This is the same for both busses. Only one is shown here. Refer to the schematic for more information.

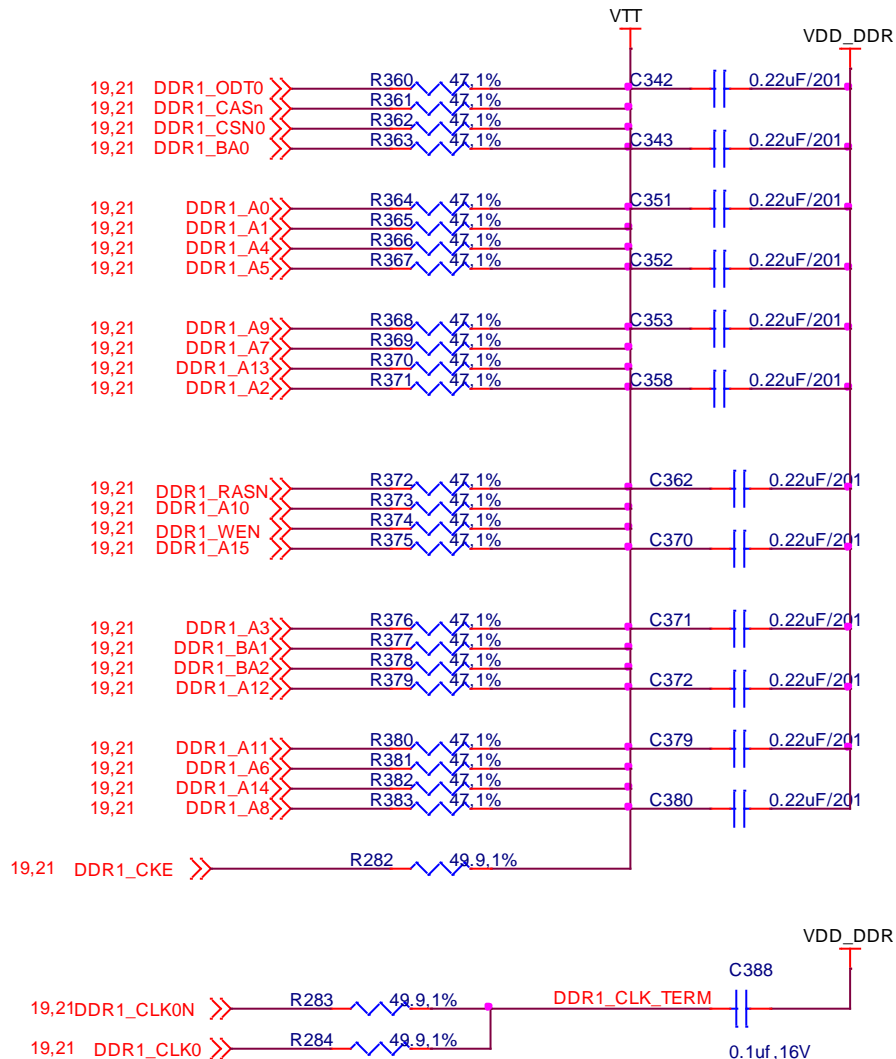

Figure 50. DDR3 Termination Resistors

4.6.3 Processor Interface

The figure below shows the connections to the processor. This is the same for both busses. Only one is shown here. Refer to the schematic for more information.

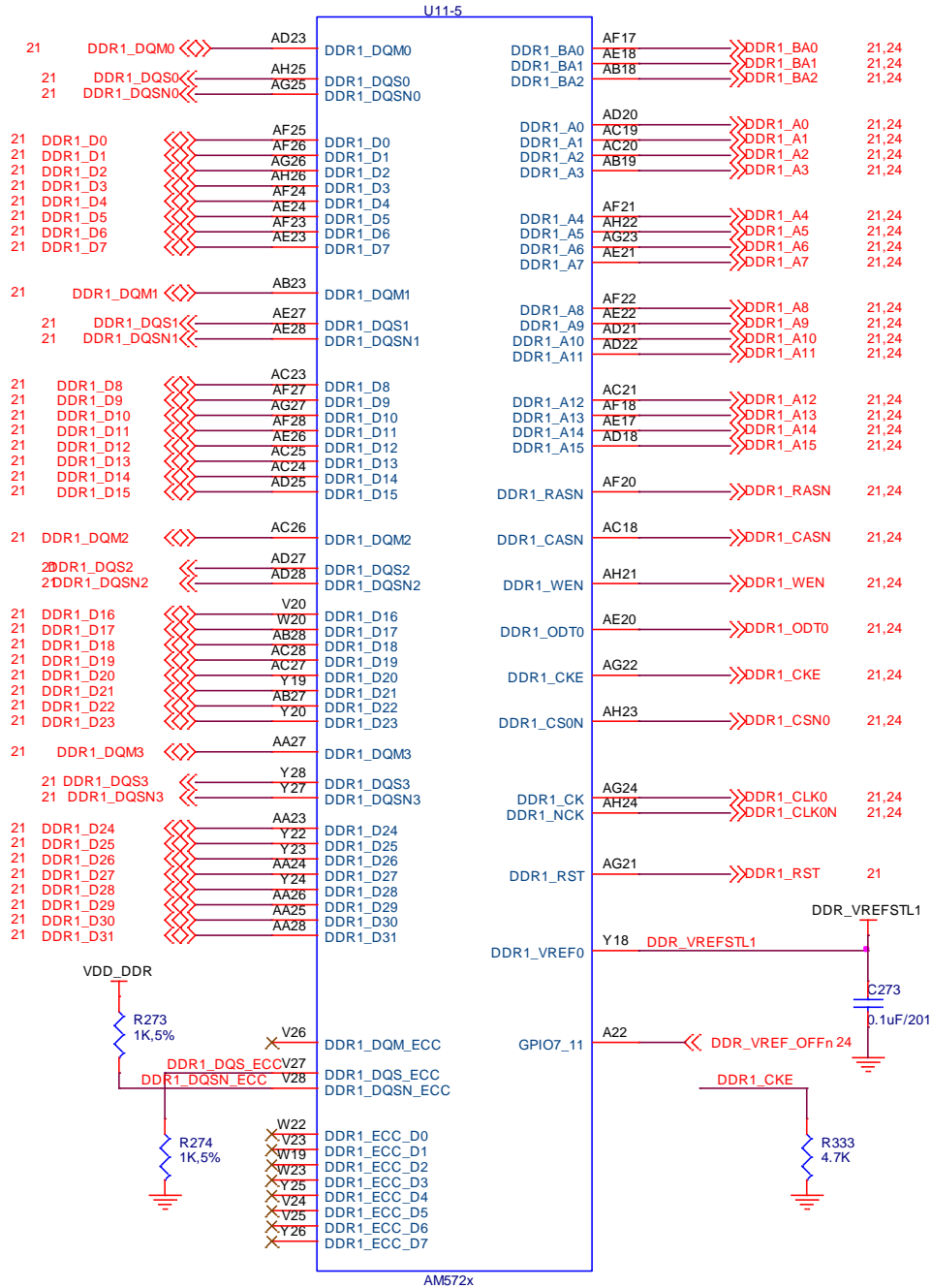

Figure 51. DDR3 Processor Interface

4.6.4 DDR3L Connections

The figure below shows the connections to the DDR3 memory device. One device has connections to DDRD0 to D15. The other device has connections to DDRD16 to D31 as shown below. You will notice that the DDR data pins are scrambled. This is done to facilitate the layout of the board and provide for an optimal layout. Address line DDR1_A15 is not used in the default configuration as shipped. If desired a 1G DDR3 part can be used, which will double the memory on the board.

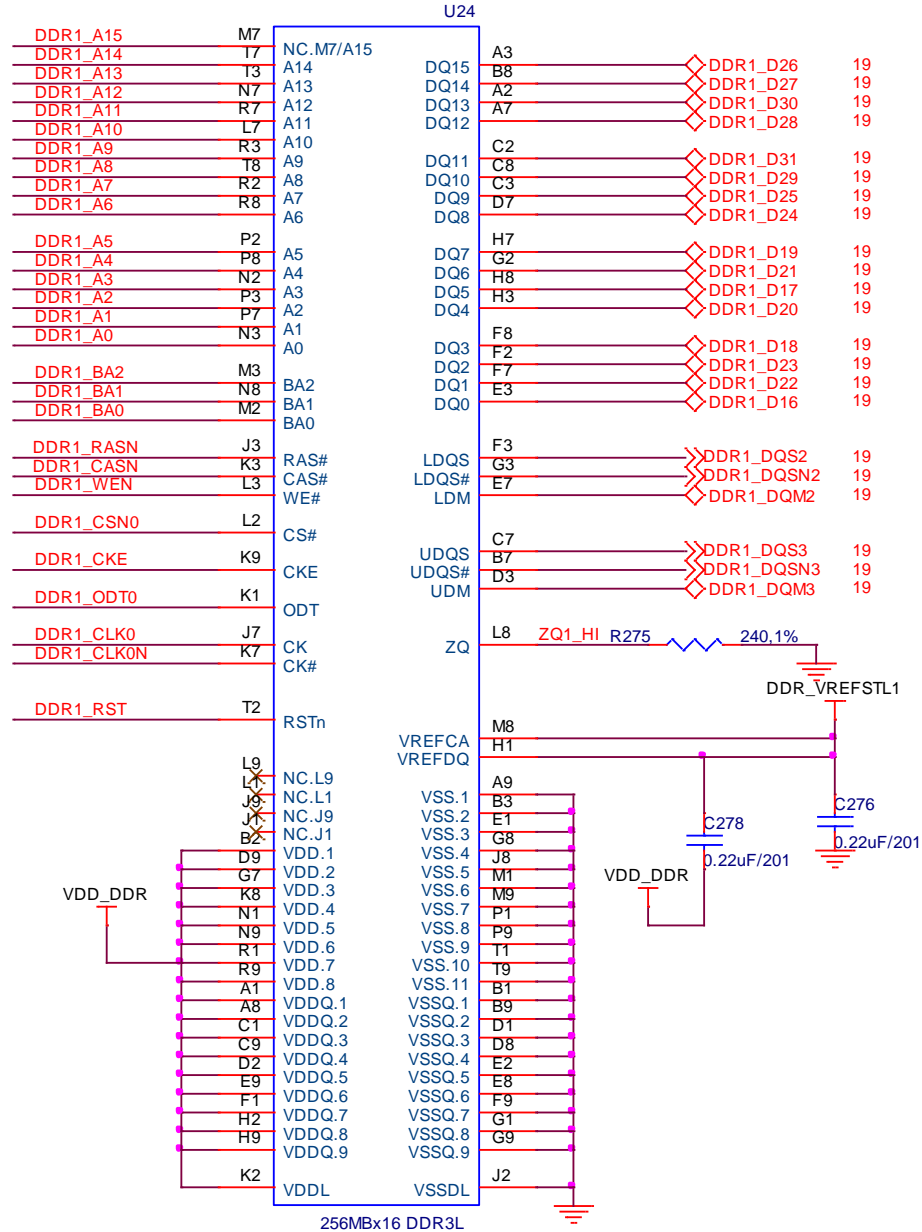

Figure 52. DDR3L Memory Device connections

4.7 4G eMMC

A single 4GB embedded MMC (eMMC) device is on the board. The device connects to the MMC1 port of the processor, allowing for 8bit wide access. This is the secondary boot device but as long as a bootable uSD is not inserted, it will be the primary boot source. The expectation is that this will be the primary boot source for the board.

Figure 21 below is the connection schematic of the eMMC to the processor.

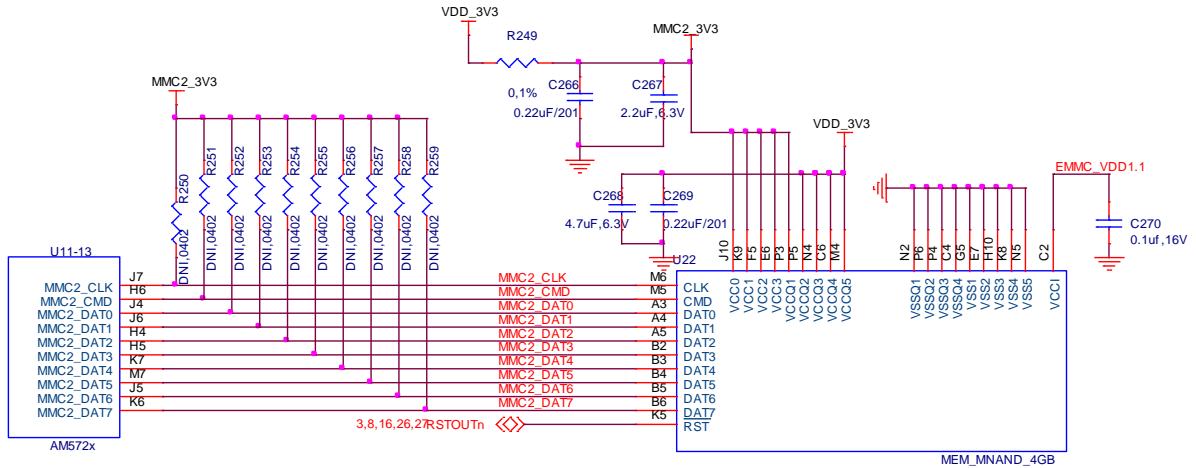

Figure 53. eMMC Circuitry

4.8 EEPROM

The board has an EEPROM for the storing of information about the board. This information can be used by the software to determine the board's information such as name and revision. When J2 is installed the EEPROM can be written to. J2 is not installed to prevent writing over the EEPROM information.

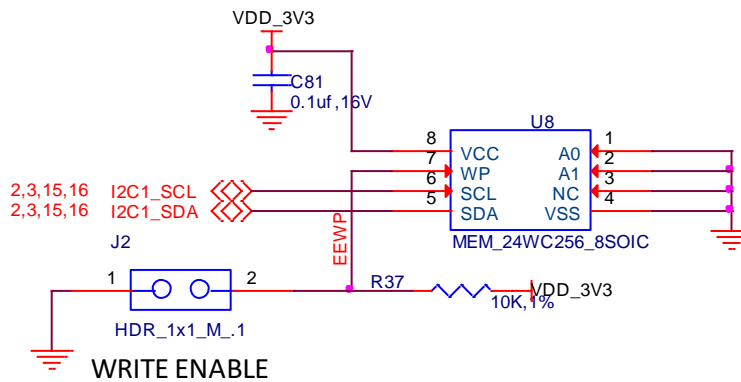

Figure 54. EEPROM Circuitry

4.9 uSD Connector

The board is equipped with a single microSD connector to act as the primary boot source for the board if inserted and configured as bootable. There is no boot button as on earlier boards. The uSD is the default boot option so if it is inserted it will boot from the uSD slot if a bootable source is present. The figure below is the circuitry for the uSD card connector.

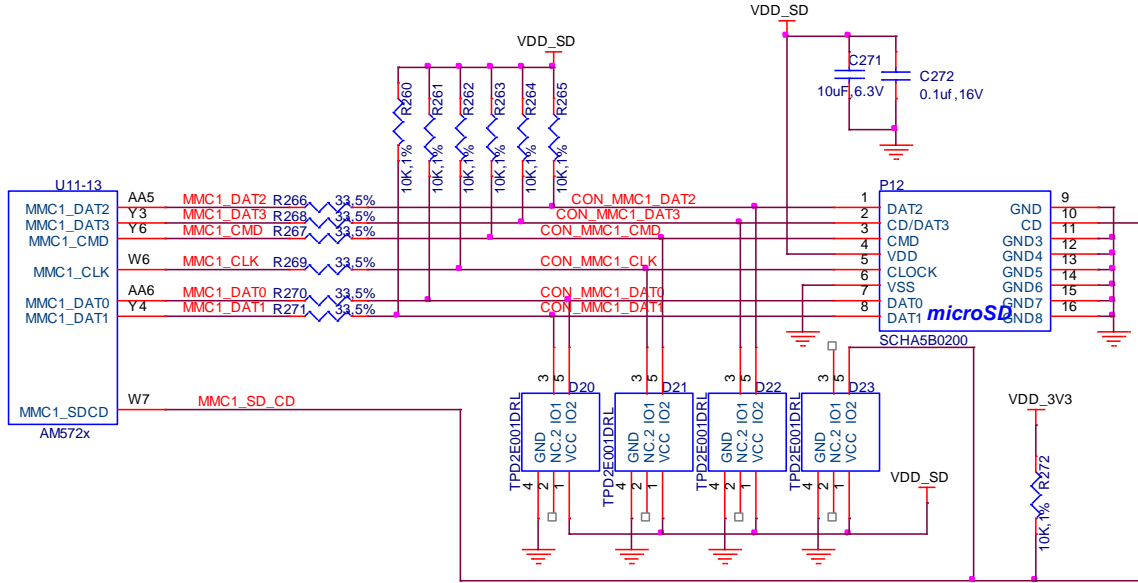

Figure 55. uSD Circuitry

4.10 Boot Modes

As supplied, the board is strapped to boot from the uSD card as default, followed by the eMMC. If desired, the user can remove the resistors and add jumpers to implement an option based boot mode scenario.

The **Table 5** below shows the modes selected by the three jumpers.

Table 5. Boot Options

		1-2	2-3
BOOT from SD then eMMC	J3		X
	J4		X
	J6		X
BOOT from UART	J3	X	
	J4	X	
	J6	X	
BOOT from SATA then SD	J3	X	
	J4		X
	J6		X

The figure below is the schematic of the boot option jumpers. By default, the board does not have the headers loaded and there are resistors that short out pins 2 and 3 of each of the jumpers.

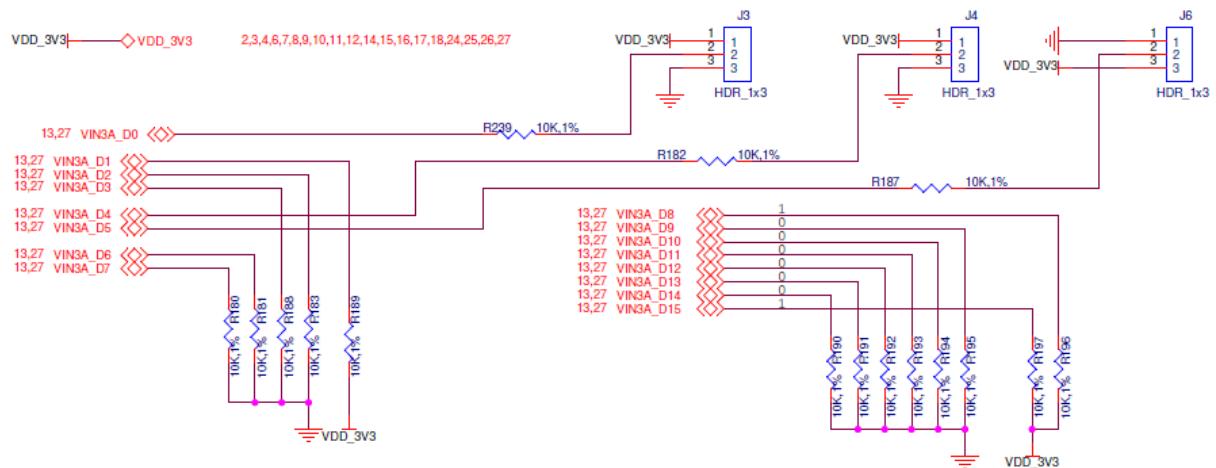

Figure 56. Boot Pin Settings

The boot pins are also routed to the expansion headers. In the event an expansion board was created, the boot modes could be overridden. Care should be taken if these pins are used for other functions, that they not be driven during power up when they are sampled for the boot setting.

4.11 I2C1 Bus

The I2C1 bus is only connected on the board and does not appear on the expansion headers. There are four devices connected to this bus:

- Board ID EEPROM
- Temperature Sensor
- TPS65074 PMIC

The figure below shows the connection between the processor and the devices.

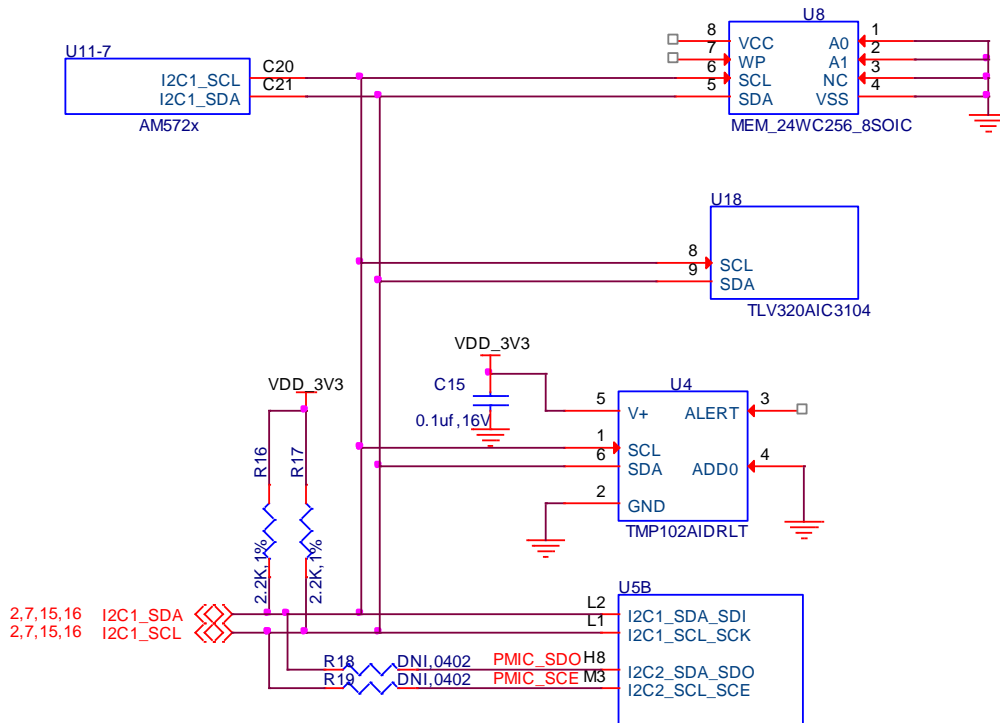

Figure 57. I2C1 Bus

The table below provides the addresses of each of the devices on the bus.

Table 6. I2C1 Device Address

DEVICE	ADDRESS	FUNCTION
TPS65039	0x58	Power Registers
TPS65039	0x59	Power resources
TPS65039	0x5A	Trimming and test
TPS65039	0x5B	OTP
TPS65039	0x12	DVS
EEPROM	0x50	Board information
TMP102	0x48	Temperature
AIC3104	0x18	Audio CODEC

4.12 Ethernet

There are two 10/100/1000 Ethernet ports on the board that connect to the RGMII interfaces of the processor. They are accessible via a stacked RJ45 connector.

Figure 58 below is the block diagram Ethernet section.

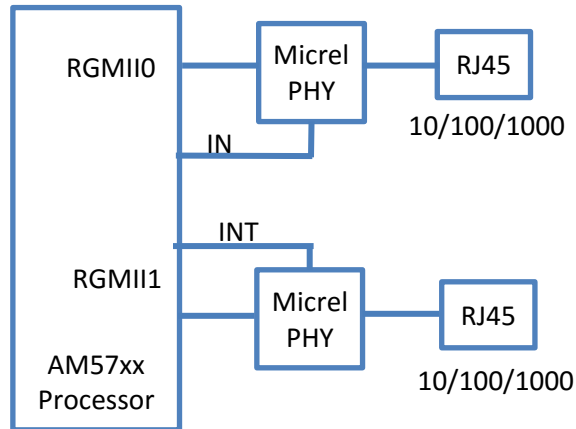

Figure 58. Ethernet System Block Diagram

The external circuitry is the same for both of the Ethernet PHY devices in the following sections only port 0 will be described.

4.12.1 Ethernet 0 Processor Interface

Figure 59 below shows the connections between the Ethernet 0 PHY and the RGMII interface of the processor.

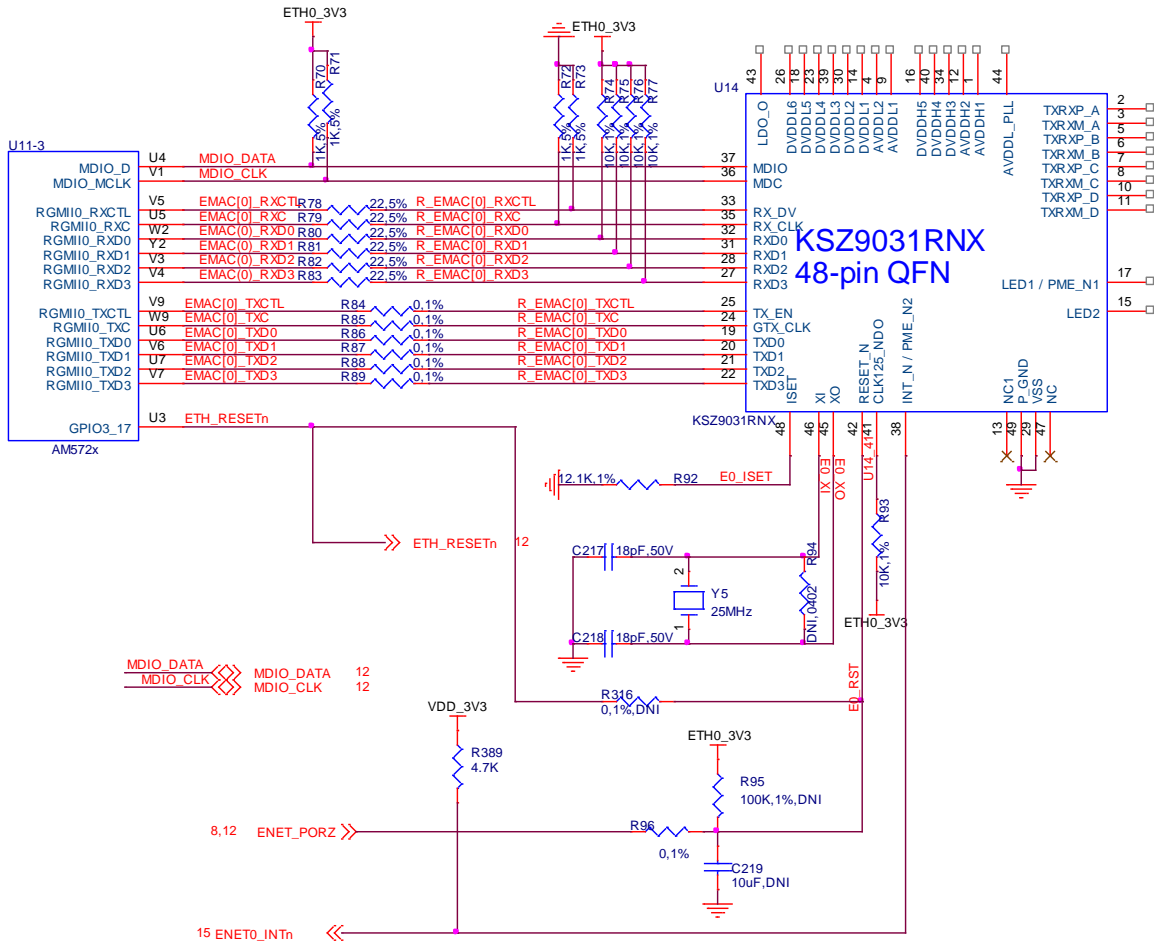

Figure 59. Ethernet 0 Processor Interface

Resistors R72-R77 are used to set the default modes of the PHY. You can refer to the KSZ9031RXN datasheet for more information on these settings.

The PHY uses a 25MHz crystal to generate the required clocks.

A series of 22ohm resistors are used in series with the RX signals from the PHY to the processor to prevent reflections. Zero ohm resistors are supplied in the TX path to provide test points if needed. They could also be used to minimize reflections if required.

An optional reset signal, GPIO3_17 is provided if there is a need for an asynchronous reset of the PHY from the processor. This is not enabled by default. It also connects to Ethernet 1 port as well.

4.12.2 Ethernet PHY Power

Figure 60 shows the power connections to the KSZ9031RNX PHY.

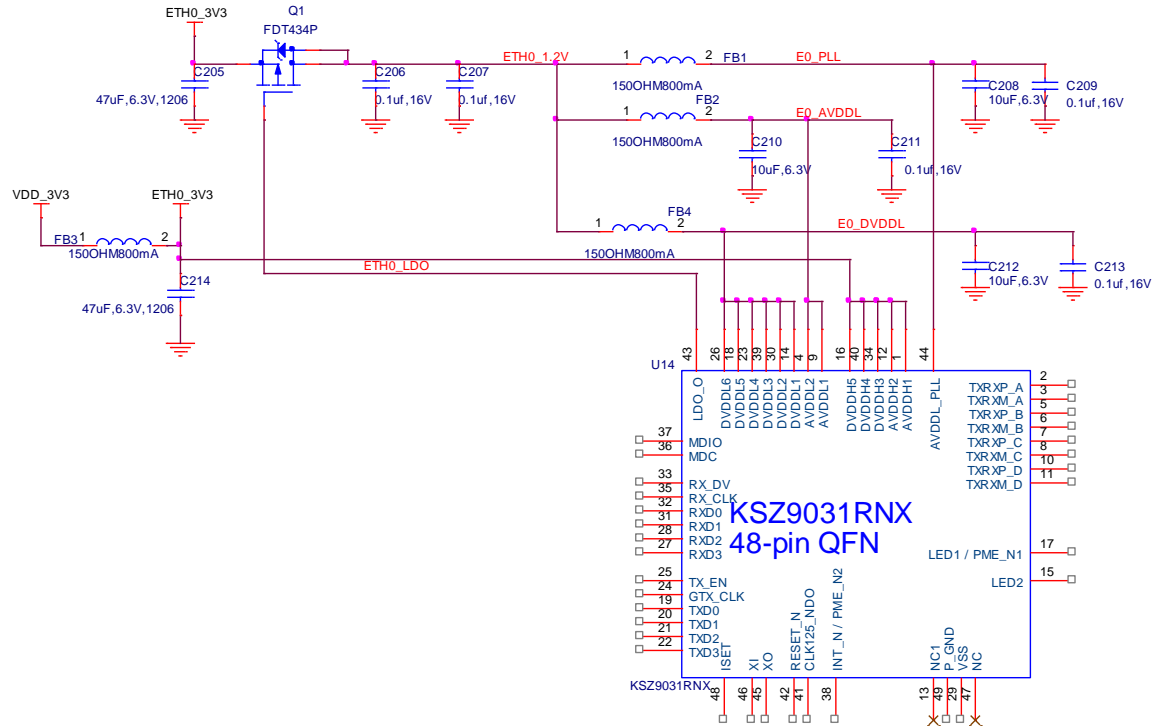

Figure 60. Ethernet Power Diagram

An external FET is required to generate the 1.2V required by the PHY core. The FET is controlled by the PHY itself. The FET requires some heat sink function which is provided by the PCB layout in the form of added copper.

All power for the PHY is derived from the VDD_3V3 rail, the main board power. Filters are provided on all rails to minimize noise.

4.12.3 Ethernet 0 RJ45 Connections

Figure 61 is the connections from the PHY to the RJ45. Each of the pairs of signals an run as differential pairs on the board layout.

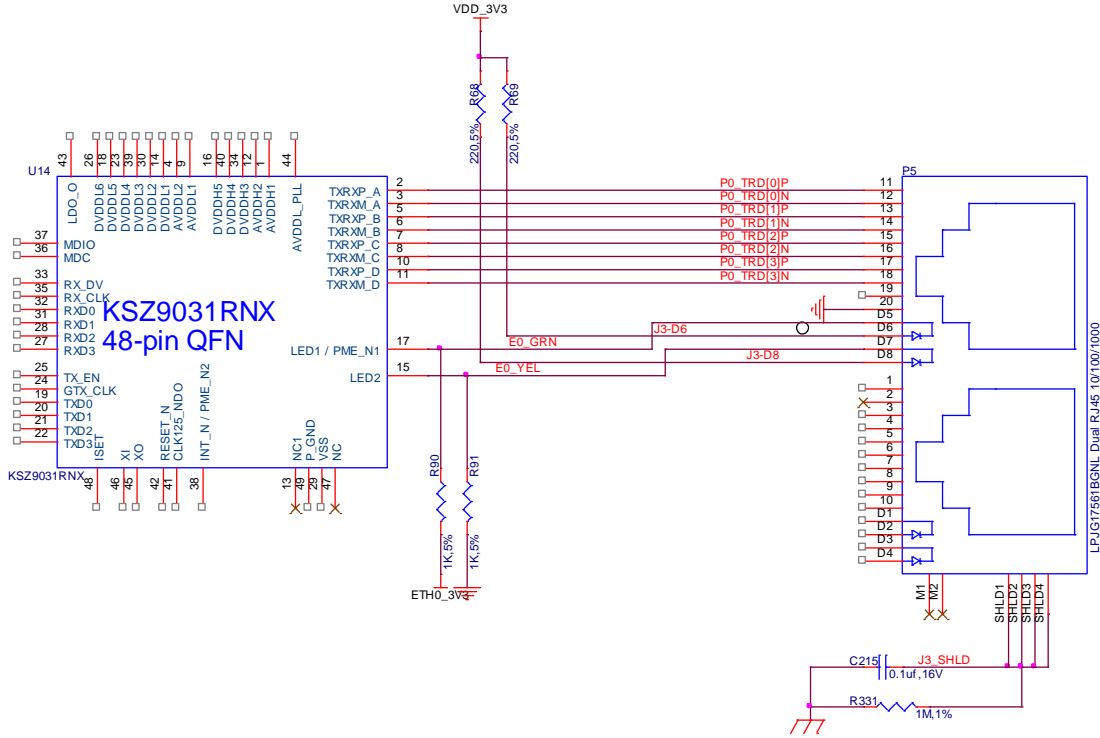

Figure 61. Ethernet RJ45 Interface

Two LEDs, one red and one green, are located in the RJ45 connector and are driven by the LED outputs of the PHY.

4.12.4 Ethernet 1 RJ45 Connections

Figure 37 is the connections from the PHY to the RJ45. Each of the pairs of signals are run as differential pairs on the board layout.

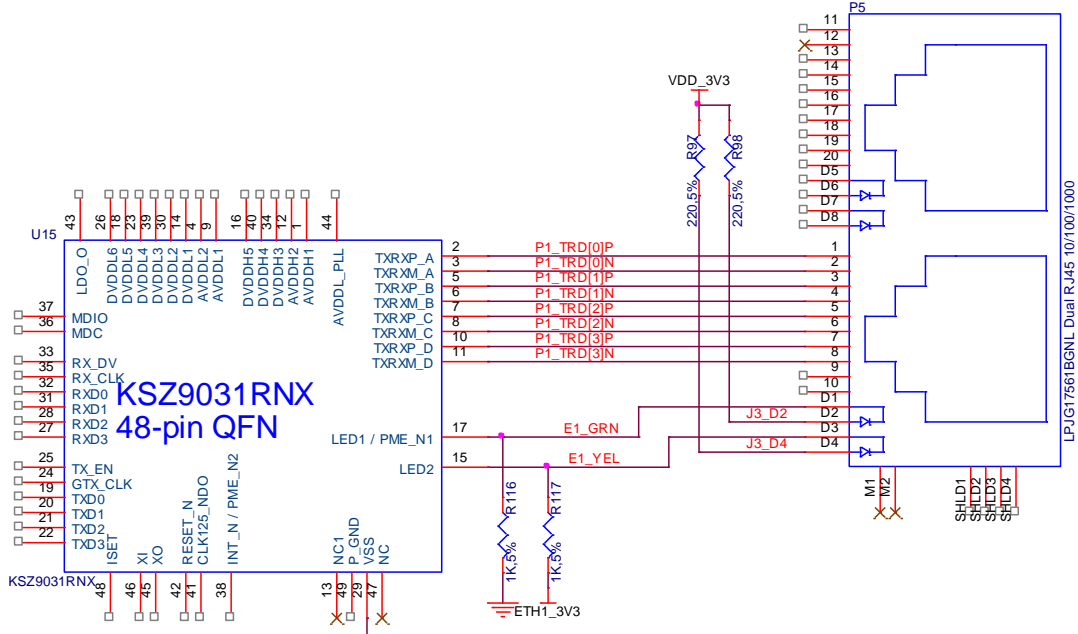

Figure 62. Ethernet 1 RJ45 Interface

Two LEDs, one red and one green, are located in the RJ45 connector and are driven by the LED outputs of the PHY.

4.13 HDMI

There is a single HDMI interface present on the processor. No external framer or circuitry other than protection circuitry is required. This interface is capable of doing 1920x180 at 60 FPS.

Figure 63 below is the HDMI interface circuitry.

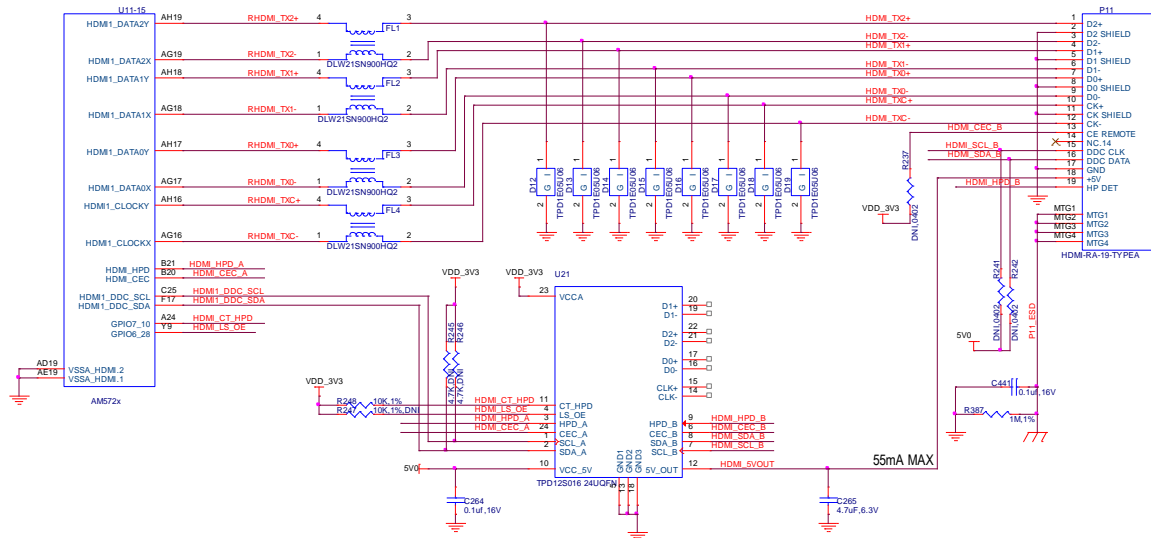

Figure 63. HDMI Interface Circuitry

Each of the output pairs are filtered using chokes FL1-FL4 specifically designed for HDMI emissions suppression. This is to help on the FCC and CE emissions testing. Also provided is ESD protection in the form of D12-D19.

U21 provides for the level shifting interface to the HDM connector. It also provides 55mA at 5V to power the EDID EEPROM on the monitor. It is not intended to provide power for a HDMI to VGA converter.

The two pullup resistors for the I2C are not populated because the level shifter has its own internal pullups.

A full size HDMI connector is used as the interface to the display.

4.1 Audio

There are two sources of audio from the board, the HDMI interface or the stereo CODEC. Only the CODEC will support Audio input. This section covers the stereo CODEC.

4.1.1 Processor Interface

Figure 64 below shows the interface between the processor and the AIC3104.

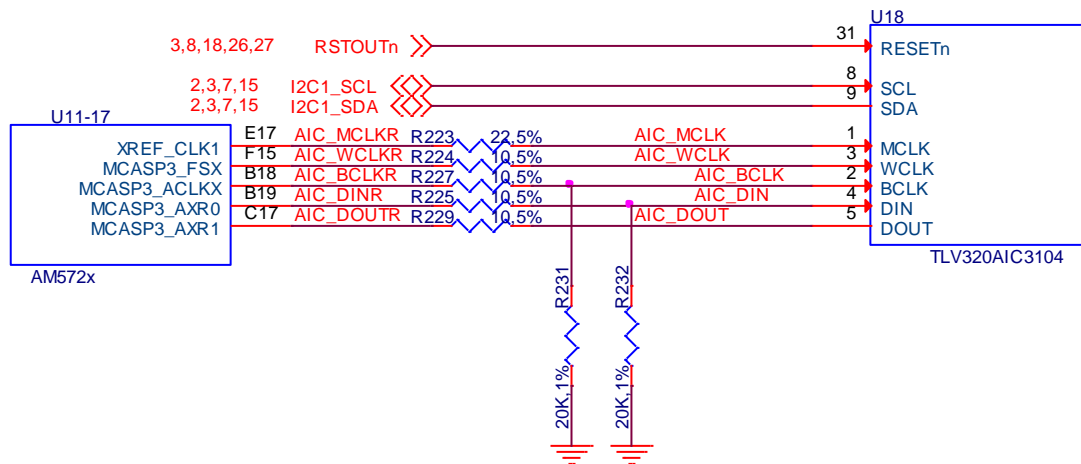

Figure 64. Stereo CODEC Processor Interface

The AIC3104 requires a master clock (**MCLK**) that is supplied by the processor using the XREF_CLK1 pin. Depending on the requirements, this clock can be any range from 512KHz to 50MHz. The most likely frequencies to be used are 12MHz, 13MHz, 16MHz, 19.2MHz or 19.68MHz.

Connection to the processor uses the McASP3 I2S interface.

RSTOUTn signal provides a reset to the AIC3014 whenever the system is reset.

The I2C1 interface is used to change the internal registers of the AIC3104. The I2C address is 0x18.

4.1.2 Power Circuitry

Figure 65 below is the power circuitry for the AIC3104.

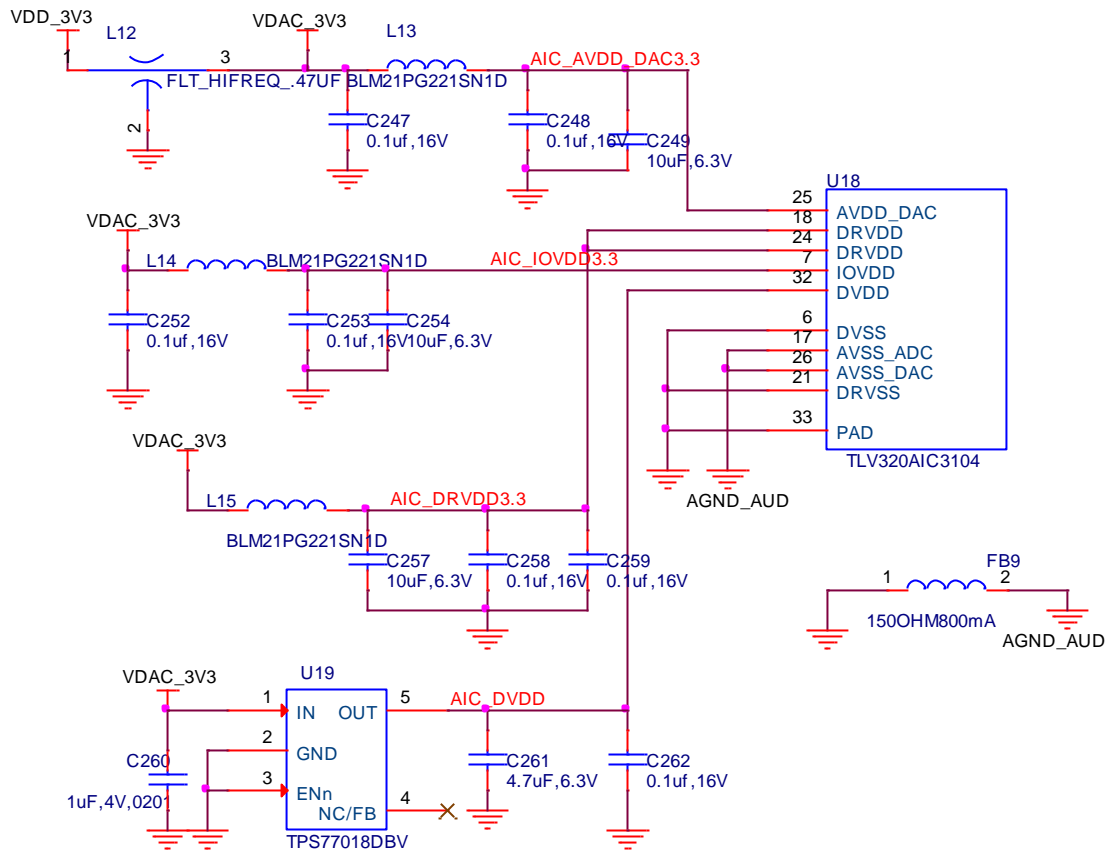

Figure 65. AIC3104 Power Circuitry

The primary power source is the VDD_3V3 rail. You will notice a filter is used on the rail in order to keep the noise down on the audio I/O. After the filter the rail becomes the VDAC_3CV3 rail. This rail is then run through ferrite beads to create the AVDD_DAC, IOVDD, and DRVDD rails.

The core circuitry inside the AIC3104 requires a 1.8V power rail on the DVDD pin. The TPS77018 device generates that voltage from the VDAC_3V3 rail.

There is a separate ground plane under the CODEC that connects to the system ground at a single point through FB9, a ferrite bead, in order to minimize any noise that might be present in the ground plane.

4.1.3 Audio In/Out

Figure 66 is the audio jacks for the Audio in and out.

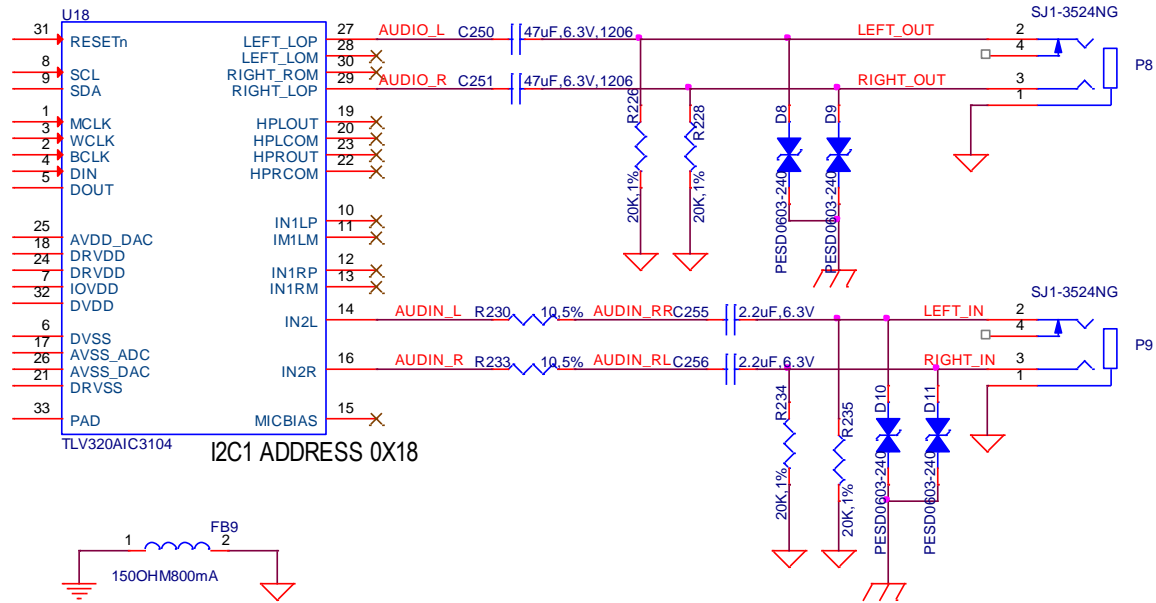

Figure 66. Stereo CODEC Audio Connections

Each of the connectors is a 3.5mm stereo jack. D8-D11 provides ESD protection for the user connections. The termination signals on the interfaces are connected to a single point ground. In the layout is a single dedicated ground for the CODEC circuitry. It is connected to the system ground through FB9.

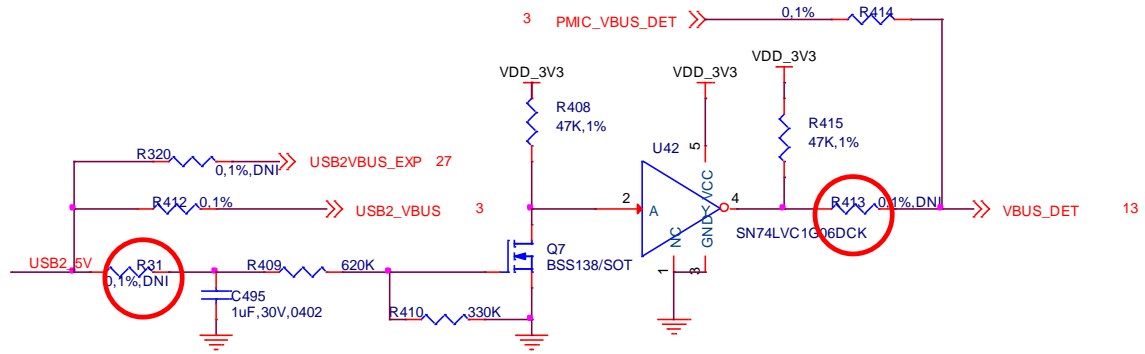

Figure 68. Alternate VBUS Detect Circuitry

4.3 USB 3.0 and HUB

There are three USB3 ports on the board, implemented by using a USB3 HUB connected to the processor. The processor only has one USB3 port and requires the HUB to handle additional ports.

4.3.1 Processor and HUB Interface

Figure 69 shows the main connections between the processor and the HUB.

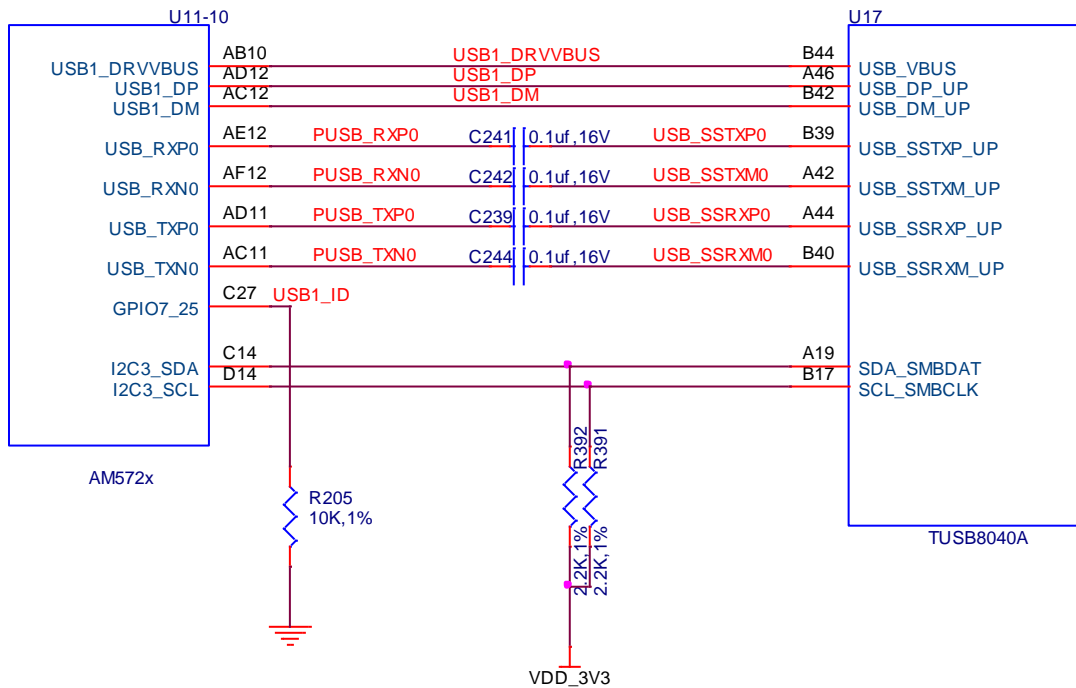

Figure 69. USB3 and HUB Processor Interface

The USB signals are connected between the HUB and the processor via capacitors. The TX and RX lines are swapped between the two.

There is not a dedicated ID pin for the ID function, so GPIO7_26 is used for that function. Pulling it low sets the port to host mode. The I2C3 port is not connected by default and is not currently being used for processor to HUB communications.

4.3.2 USB3 Port Power Control

Figure 70 is the power control for the USB3 ports. Each rail is controlled by the USB HUB. Each voltage rail has filter caps, bulk caps, and a ferrite bead for noise emissions reduction. Resistors R293 and R298 set the current limit on each of the switches. Ports 1 and 2 are set for the 1200mA charge current. Only port one has that function enabled at the HUB. The other USB3 port, port 3, is set for 900mA.

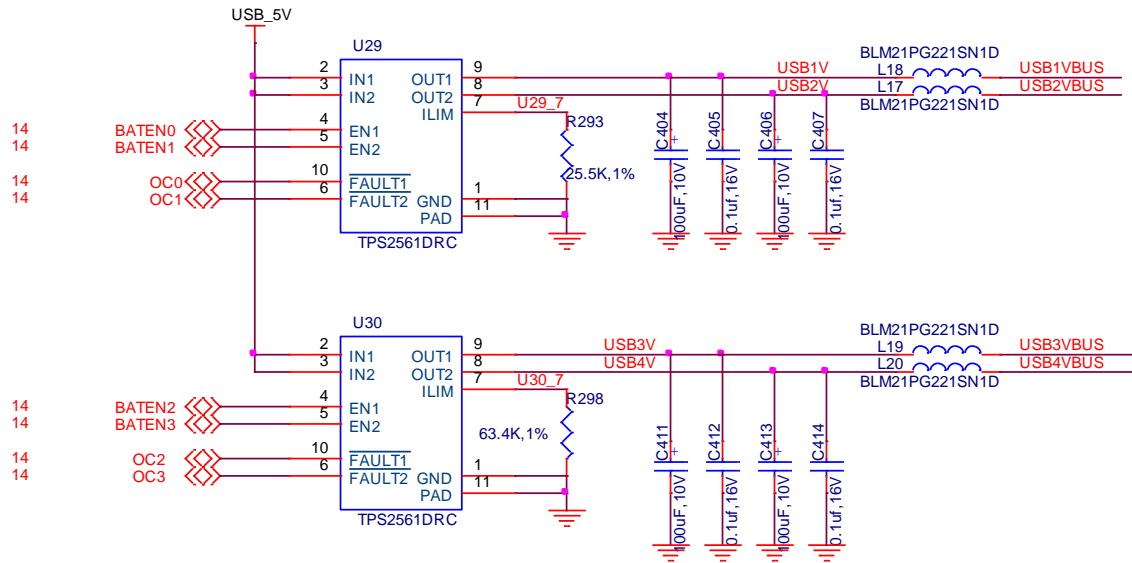

Figure 70. USB3 Power Control

The USB4VBUS is in support of the eSATA connector and can deliver 900mA to the eSATA port.

4.3.3 USB3 Port Connectors

Figure 71 shows connections to the connectors on the board. The port has ESD protection on all signals. P13 is a single USB 3.0 connector.

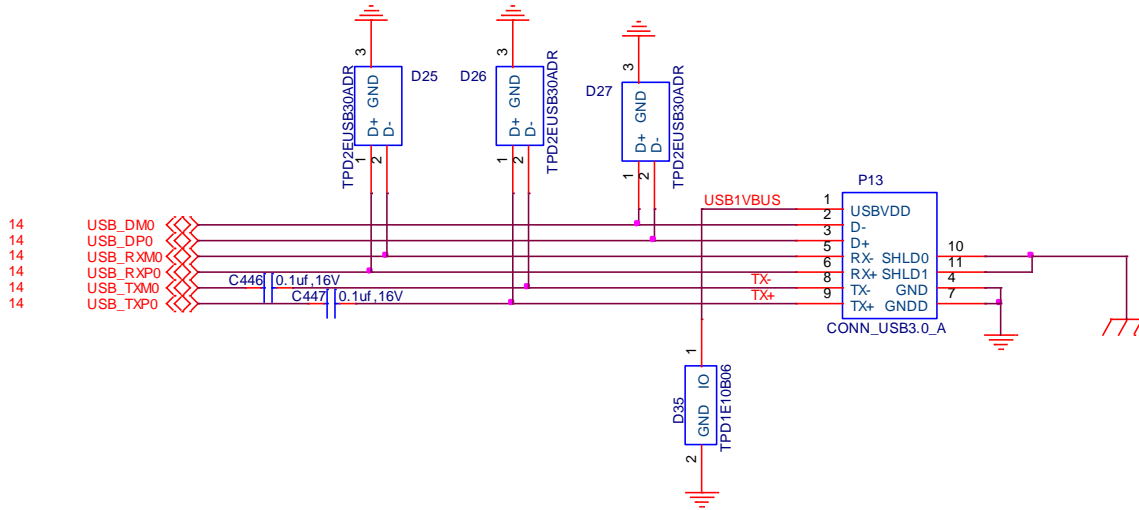

Figure 71. USB Port 1 Connectors

Figure 72 shows the connection for USB3 ports 2 and 3. P15 is a dual stacked UBS 3.0 connector. Each pin has a dedicated ESD device.

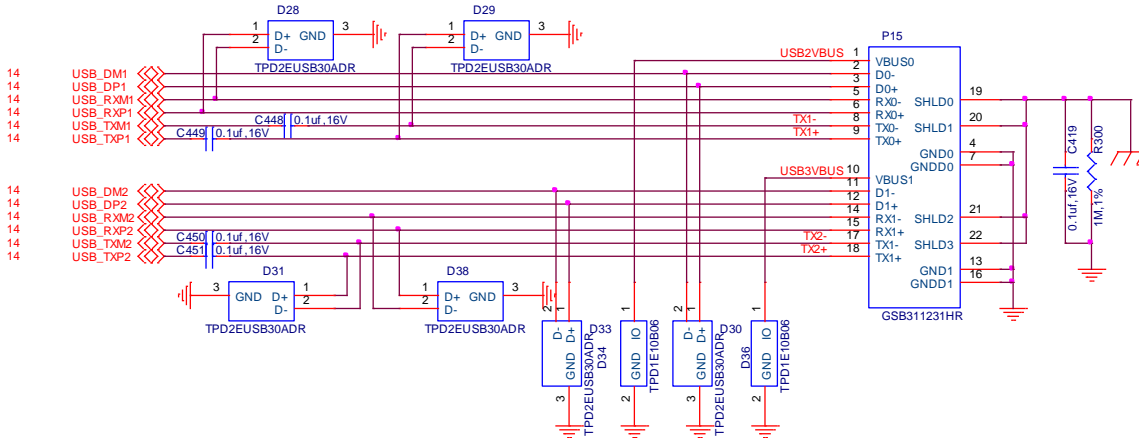

Figure 72. USB Port 2 and 3 Connectors

4.4 eSATA/SATA

Figure 73 is the block diagram of the SATA section.

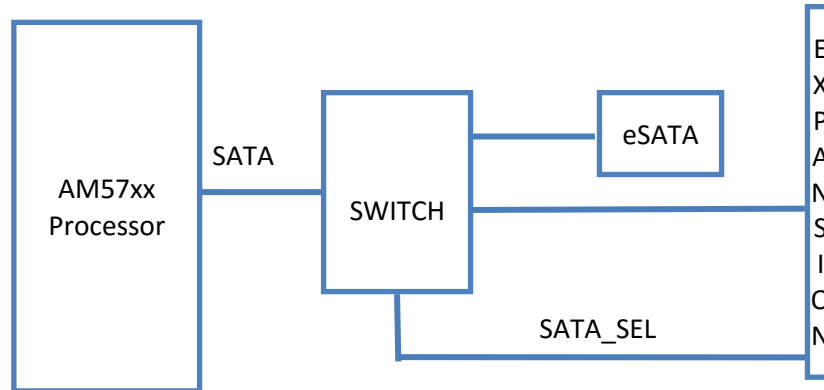

Figure 73. eSATA Block Diagram

A switch is used to direct the SATA signals to the onboard eSATA connector or to the expansion header, where they can be used by add-on boards. If the signal on the expansion header, P19-4, is left open, the signals go to the eSATA onboard connector. If the pin is grounded, the switch is activated and the signals are routed to the expansion headers. If the SATA signals are routed to the expansion headers, the eSATA connector can still be used as USB port.

The **Figure 74** is the detailed design of the eSATA interface. The eSATA interface is a combination of two separate interfaces, SATA and USB. The eSATA port can be used as an eSATA or a USB 2.0 port. Power for the eSATA is from the USB power pins, 5V.

The USB signals originate from the USB 3.0 HUB. The SATA interfaces originate from the AM5728 processor via the switch.

Power is routed to the eSATA connector via the TPS2560 FET switch. It is capable of providing the 5V at 900mA required by the eSATA connector.

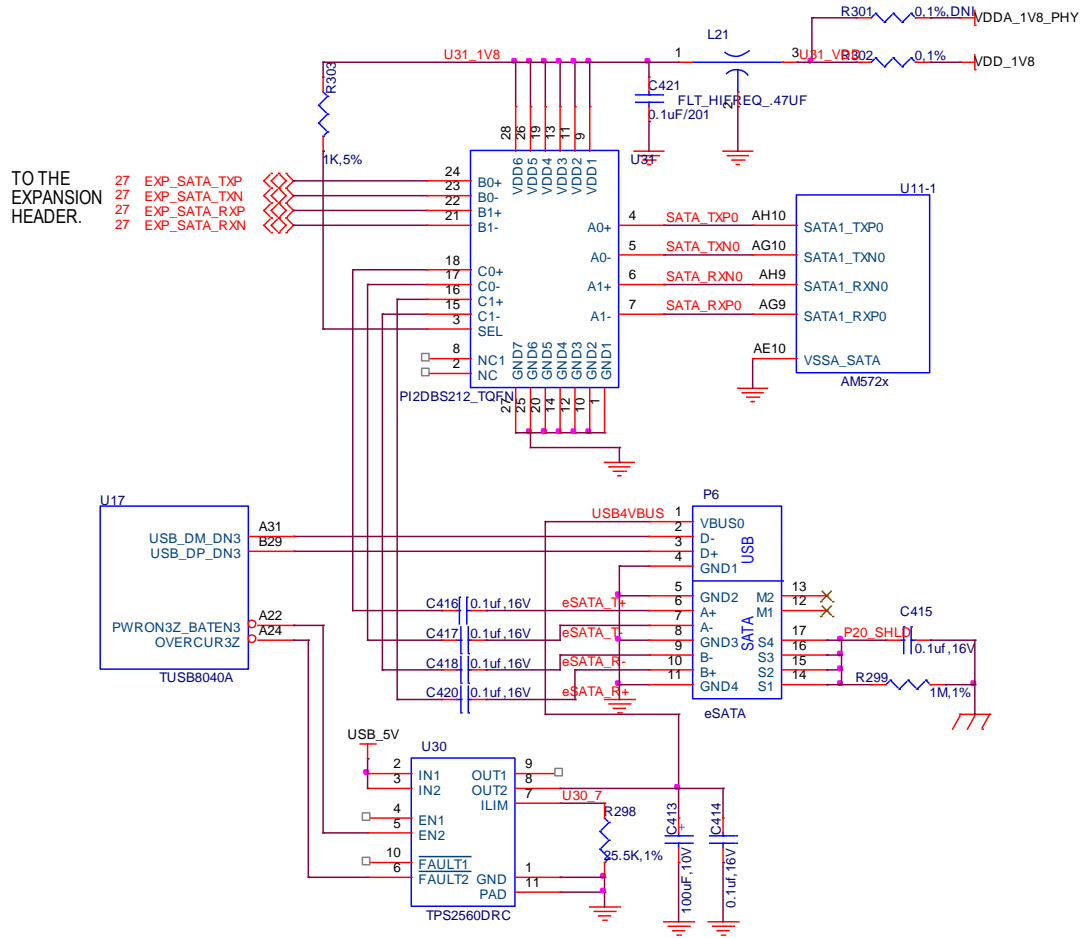

Figure 74. eSATA Circuitry

4.5 Serial Debug Port

The **Figure 75** is the serial debug port on the board. It provides TX, RX, and ground signals. The SN74LVC2G241 is an isolation buffer to prevent the signals from being fed back into the processor when the board is powered off.

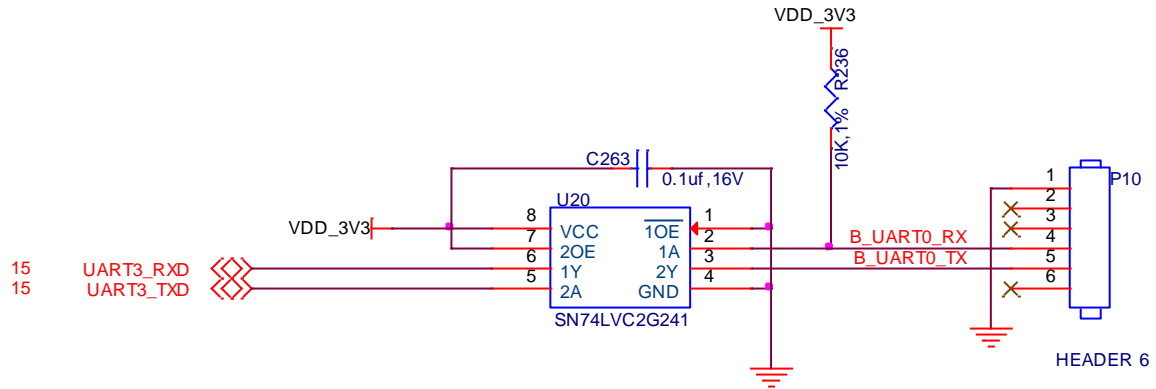

Figure 75. Debug Serial Port

The TX and RX signals are 3.3V level. In order to connect them to a PC, a USB to serial converter is required. A common one is the FTDI USB to TTL cable as shown in **Figure 76** below. May sure you use the 3.3V version and not the 5V version.



Figure 76. FTDI USB to Serial Adapter

4.6 JTAG Connector

A JTAG connector is provided for those requiring advanced debug capability. Because the AM5728 processor has a pair of DSPs, those using the DSP may find this feature very useful. **Figure 77** below shows the connection diagram.

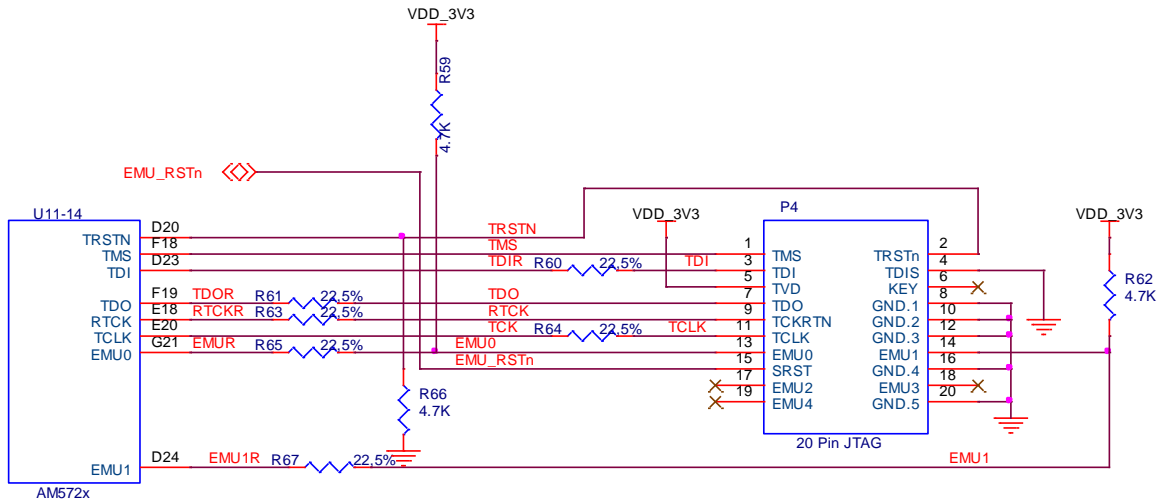

Figure 77. JTAG Port

4.7 Temperature Sensor

A TMP102A temperature sensor is located near the processor. There is also a temperature sensor inside the processor. This sensor is intended to measure the ambient temperature near the processor. The sensor is connected to the I2C3 bus on the processor. The alert pin that indicates the the temperature has exceeded the set limit is connected to GPIO7_16. **Figure 78** below shows the temperature sensor circuitry.

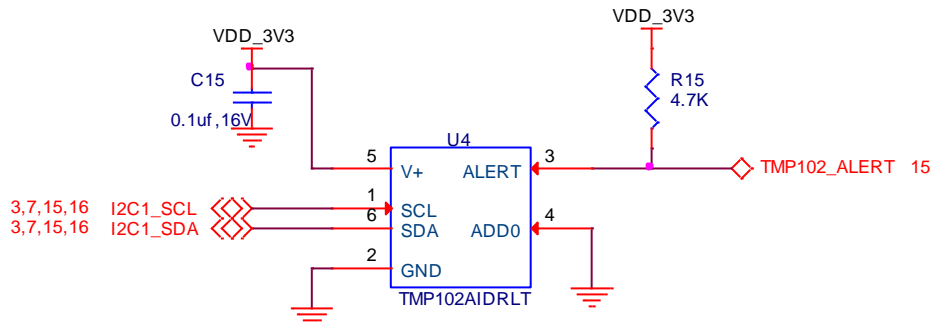

Figure 78. Temperature Sensor Circuitry

4.8 Real Time Clock

A battery back external Real Time Clock (RTC) MCP79410 is provided to keep the current clock active while the board is powered down. It can be used in conjunction with the internal Real Time Clock of the processor which will reset when power is removed from the board.

In addition to the typical RTC functions, the device has 64 bytes of battery backed RAM and 1Kb of EEPROM.

The CR1229 non-rechargeable battery supplies 35mAh of backup power which is sufficient to keep the RTC active for a couple of years. Make sure you do not short the battery by placing the board on a conductive surface when not in use as you will lose the time.

Figure 79 below is the RTC circuitry.

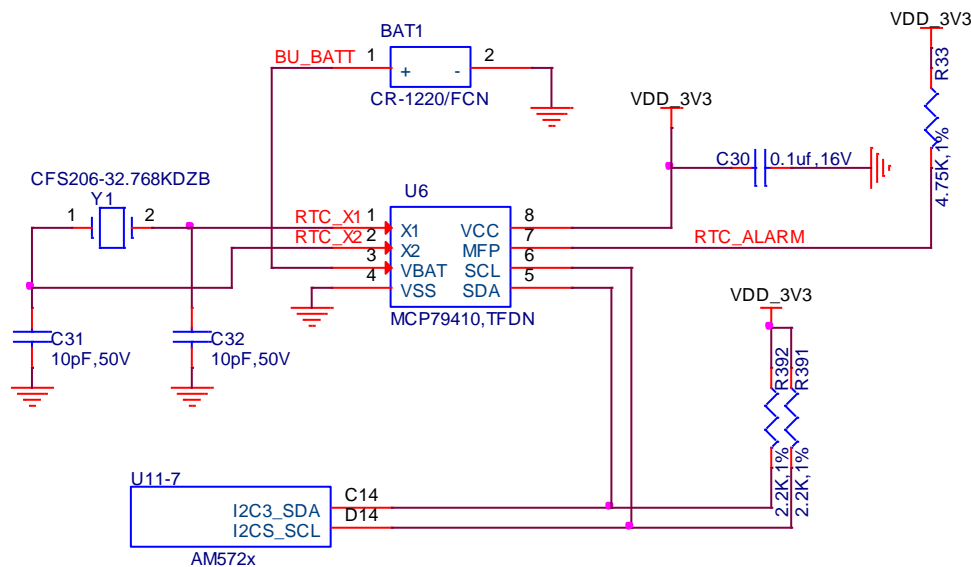

Figure 79. Real Time Clock Circuitry

The RTC_ALARM connects to the Wakeup3 signal on the processor.

Communication to the processor uses the I2C3 bus. Registers and settings can be found in the RTC datasheet.

4.9 User LEDs

There are four User LEDs on the board. By setting the corresponding GPIO pin to a 1, the LED will turn on. **Figure 80** shows the User LED circuitry.

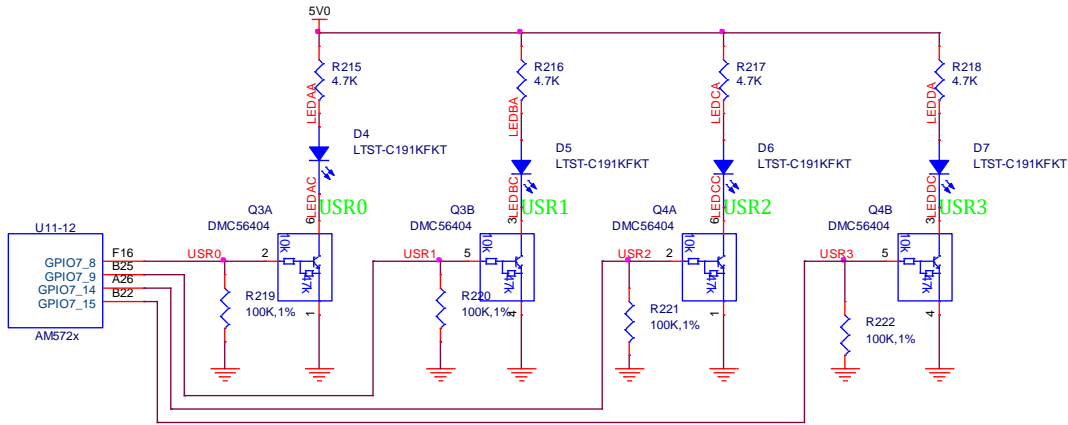

Figure 80. User LEDs Circuitry

Table 7 below gives the GPIO pins used for each LED.

Table 7. User LED GPIO Mapping

LED	GPIO PIN
USER0	GPIO7_8
USER1	GPIO7_9
USER2	GPIO7_14
USER3	GPIO7_15

4.10 Forgotten Pins

If you look on page 15 of the schematics, you will see a group of pins that are not used. **Figure 81** shows those pins.

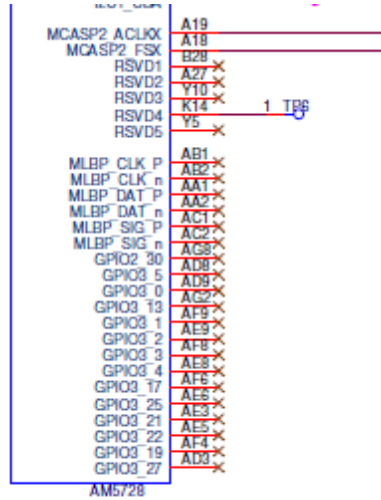

Figure 81. Forgotten Pins

These pins are useable from the AM5728 processor. The original design of the X15 was to support both the AM5728 and the AM5718 processor with the AM5718 being the lead for the design. In other words the plan was to make it work best of the AM5718. Along the way things shifted toward the AM5728 as the initial processor. Those pins have different functions on the AM5718, so they were not brought out to create a compatibility scenario so as not to lose features when moving between the processors.

For more information on the differences between the two processor go to <http://www.ti.com/lit/an/sprabx8b/sprabx8b.pdf>

5.0 Expansion Connectors

There are four expansion connectors on the board. The connector used are the Hirose FX18 series. **Figure 82** below is a picture of the connector.

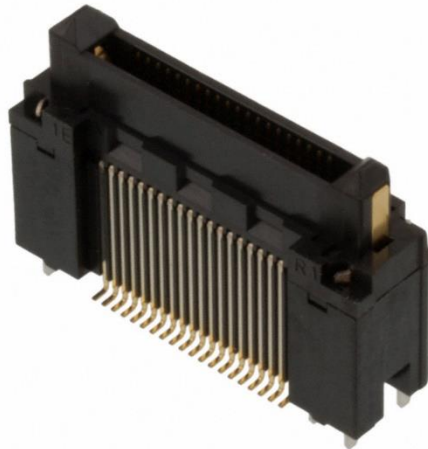

Figure 82. Expansion Connector

When the alpha board was designed, .025 pins and headers were used. The insertion force and retention force of those connectors made them impossible to use as there were too many signals. It was impossible to get the boards pulled apart.

On the final version the Hirose connector was used to reduce the insertion and removal force significantly and to provide for higher speed signal handling required by the PCIe and SATA signals.

5.1 Expansion Header Pinouts

The following pages cover the functions found on the expansion headers. The actual pinout is not covered in this document. This information can be found in the [Pin Map](#) spreadsheet that is sortable on all columns, making it easier to search for pins across various categories such as:

- By expansion header
- By function (PRU, LCD, etc.)
- By name

The Pin Map spreadsheet can be found on the X15 Support Wiki.

<http://elinux.org/BeagleBoard:BeagleBoard-X15>

5.1 Creating and Expansion Board

The expansion connectors are located on the bottom side of the board. There are three possible options for creating your own expansion board.

- Create a board that connects to one expansion connector
- Create a board that connects to two of the connectors
- Create a board that connects to all 4 connectors

Figure 83 below shows the dimensions of the board and the placement of the connectors. This view is looking through the X15. This would also be the same view used for any expansion board that were designed. The expansion board mounts on the back side of the board. **DO NOT** mount the X15 under the expansion board, unless it is mounted at an angle to where you get proper airflow, such as when used with an LCD panel.

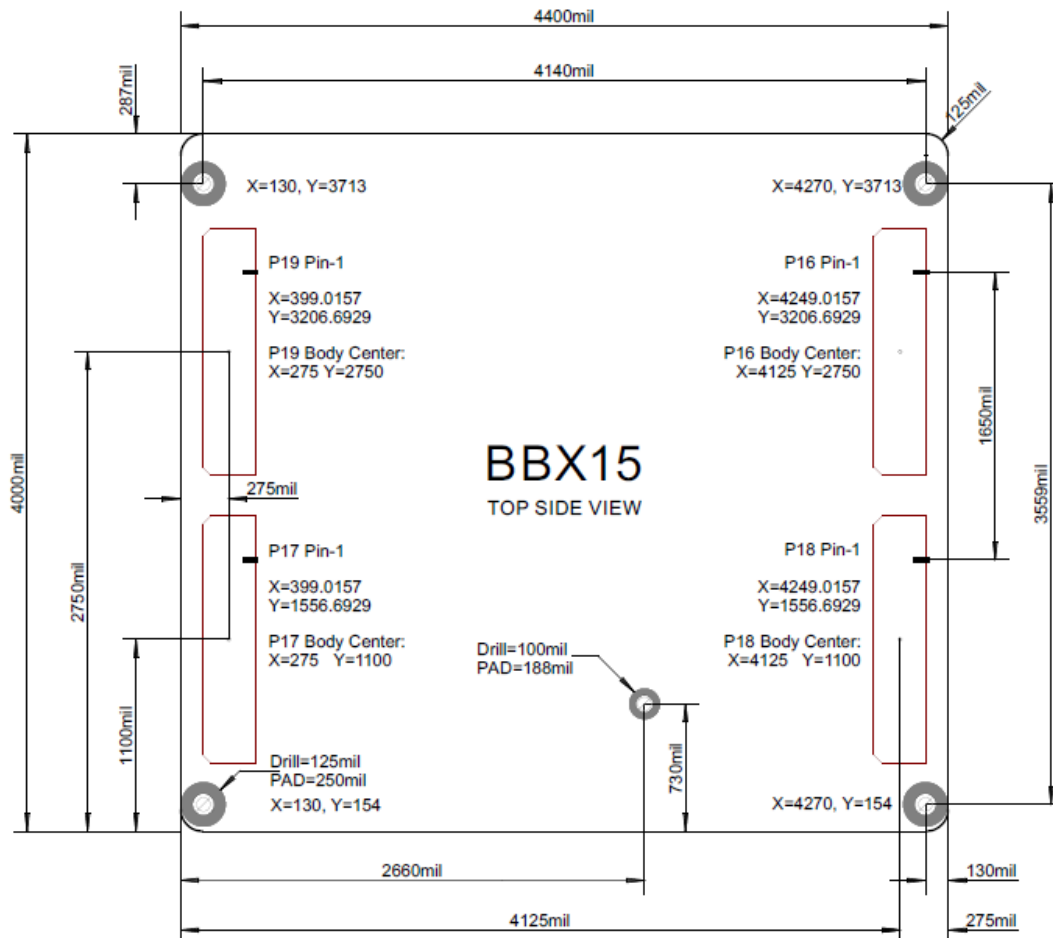

Figure 83. Expansion Board Measurements

The mating connector is the **Hirose FX18-60S-0.8SV15**. If you need different heights than this one, they are available as well. **Figure 84** is a picture of this connector.

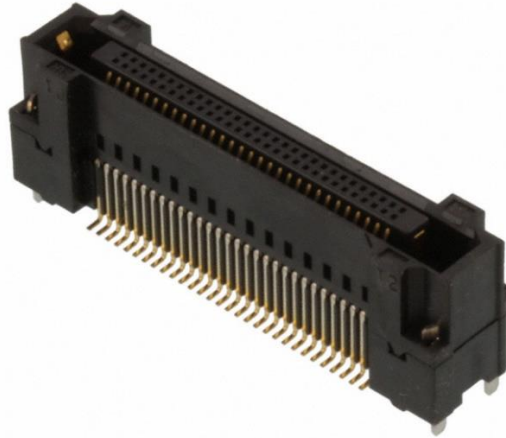

Figure 84. Expansion Mating Expansion Connector

These connectors can be purchased from the following suppliers:

<http://www.digikey.com/product-search/en?keywords=FX18-60S-0.8SV15>

<http://www.mouser.com/ProductDetail/Hirose-Connector/FX18-60S-08SV15/?qs=sGAEpiMZZMvffgRu4KC1R93sqY37AFrhtQh7fBPpuqI%3d>

<http://www.newark.com/hirose-hrs/fx18-60s-0-8sv15/connector-rcpt-60pos-2row-0-8mm/dp/59Y7142?ost=FX18-60S-0.8SV15&categoryId=&categoryName=>

<http://www.sager.com/fx18-60s-0-8sv15-3614937.html>

<https://estore.heilind.com/FX18-60S-0.8SV15/HIRFX18-60S-0.8SV15.html>

Supply will vary so leave yourself enough time when ordering the parts.

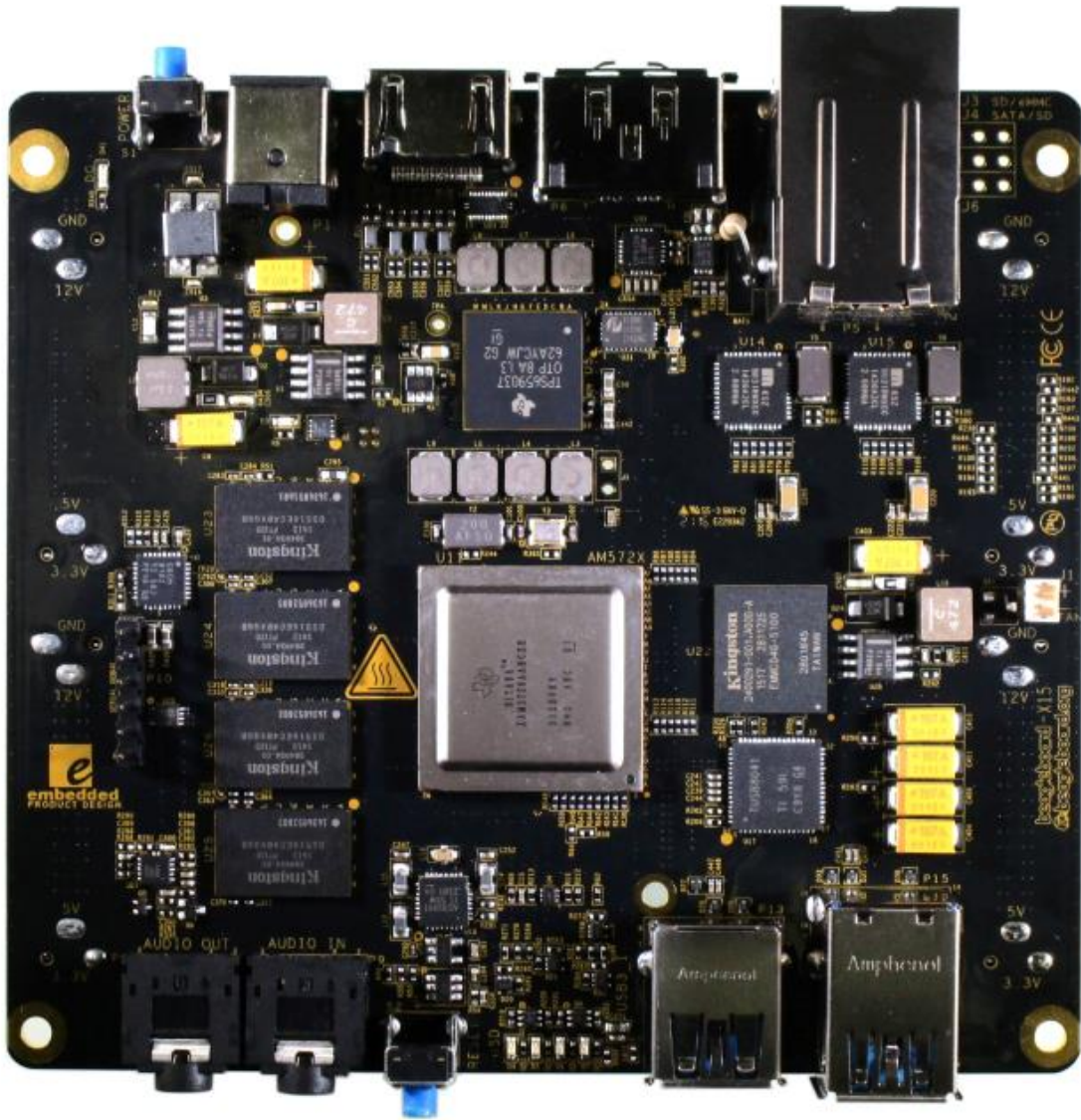

Figure 85. X15 Top Side View

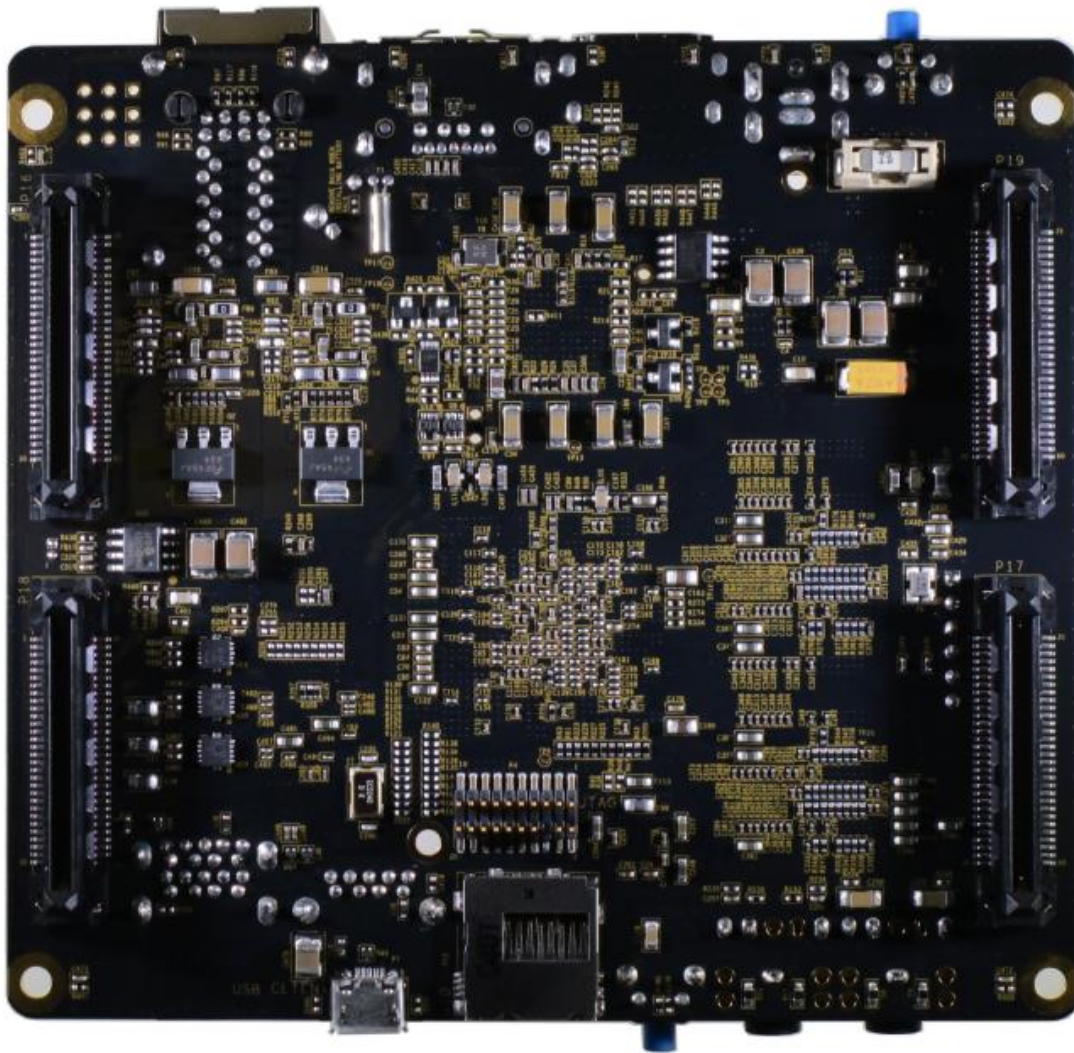

Figure 86. X15 Bottom Side View

X-ON Electronics

Largest Supplier of Electrical and Electronic Components

Click to view similar products for [Single Board Computers](#) category:

Click to view products by [BeagleBoard](#) manufacturer:

Other Similar products are found below :

[MANO882VPGGA-H81](#) [SSD3200W-S-SLC-INN 20-101-0738](#) [MVME61006E-2173R](#) [SHB230DGGA-RC](#) [CM2-BT2-E3825-ETT](#)
[IMB210VGGA](#) [IB915F-3955](#) [MI958F-16C](#) [S2600WFT](#) [S2600STB](#) [BBS2600BPS](#) [BLKNUC7I3DNHNC1978015](#) [DEV-17745](#)
[BEAGLEBOARD POCKET](#) [MICROSOM I2 + WIFI/BT](#) [HUMMINGBOARD-I2EX BASE + WIFI/BT](#) [HUMMINGBOARD-I4 PRO +](#)
[WIFI/BT](#) [VAB-600-B](#) [MITX-440-DVI-2E](#) [ATCA-7365-D-24GB](#) [NITX-315-DEVKIT](#) [A13-SOM-512](#) [NITX-315](#) [BANANA PI BPI-M1+](#)
[A13-SOM-WIFI-4GB](#) [AM3359-SOM-EVB-IND](#) [UPS-APLC2-A10-0432](#) [DFR0419](#) [UPS-APLP4-A10-0864](#) [UPS-APLP4-A10-0432](#) [UPS-](#)
[APLP4-A10-08128](#) [MI977F-Q27](#) [BBBLUE](#) [IB811F-I30](#) [DFR0470-ENT](#) [Nit6Q_i](#) [M2M \(TELIT\)](#) [RELAY](#) [PROFESSIONAL](#)
[GCS22.2.080.2.2.I](#) [GCS22.8.100.4.2.I](#) [GLS11.2.053.2.2.E](#) [A20-OLINUXINO-LIME-E16GS16M](#) [A20-OLINUXINO-LIME-S16M](#) [A20-](#)
[OLINUXINO-LIME2-E16GS16M](#) [A20-OLINUXINO-MICRO-S16M](#) [BANANA PI BPI-W2](#) [T2-OLINUXINO-LIME2-S16M-IND](#) [T2-](#)
[OLINUXINO-MICRO-E8GS16M-IND](#)