



H38 | INCREMENTAL OPTICAL ENCODER



Introduction

The H38 is an explosion proof version of the field-proven H25 encoder series. The H38 is UL certified for NEMA Class 4X and 6 (outdoor nonhazardous locations) and Class 4X and 13 (indoor non-hazardous locations). It is available with single and triple certifications for use in hazardous locations and includes a standard shaft seal, double bearing seals, and a cast aluminum housing with hard anodized and dichromate sealed finish. The H38 is suitable for use in petroleum service industries, solvent refining operations, spray painting applications, and explosive dust environments.



SPECIFICATIONS

Mechanical

Shaft Diameter	3/8" nominal
Shaft Loading	Up to 40 pounds axial and 20 pounds radial applied 1/4" from housing
Shaft Runout	0.0005 T.I.R
Starting Torque at 25°C	4.0 in-oz (max)
Bearings	Class ABEC 7 standard
Shaft Material	303 stainless steel
Enclosure	Die cast aluminum, hard anodized with dichromate sealed finish. Shaft seals and sealed bearings are standard to achieve environmental ratings.
Bearing Life	2 X 10 ⁸ revs (1300 hrs at 2500 RPM) at rated load; 1 X 10 ¹⁰ revs (67,000 hrs at 2500 RPM) at 10% of rated load
Maximum RPM	10,000 RPM (see frequency response, below)
Moment of Inertia	4.1 X 10 ⁻⁴ oz-in-sec ² UL & MSHA/ 1.7 X 10 ⁻³ oz-in-sec ² CEN
Weight	64 oz typical (approx 4 lbs)



Electrical

Code	Incremental
Output Format	2 channels in quadrature, 1/2 cycle index gated with negative B channel
Cycles per Shaft Turn	1 to 72,000 (see table 2, page 5). For resolutions above 3,600 see Note 7.
Supply Voltage	5 to 28 VDC
Current Requirements	100 mA typical +output load, 250 mA (max)
Voltage/Output	(see note 3) 15V/V: Line Driver, 5–15 VDC in, $V_{out} = V_{in}$ 28V/V: Line Driver, 5–28 VDC in, $V_{out} = V_{in}$ 28V/5: Line Driver, 5–28 VDC in, $V_{out} = 5$ VDC 28V/OC: Open Collector, 5–28 VDC in, OCout
Protection Level	Reverse, overvoltage and output short circuit (see note 3)
Frequency Response	100 KHz Typical, Higher frequency response available, see note 5
Output Terminations	see Table 1, page 5
Termination Type	Compression type, UL recognized. Accepts AWG 14 to 22, stranded wire, strip 1/4"
Note	Consult factory for other electrical options

Environmental

Enclosure Rating	NEMA 4 X & 6 (IP66), outdoor Non-Hazardous locations, NEMA 4 X & 13 (IP66), indoor Non-Hazardous locations
Temperature	Standard operating all models, 0° to +70°C; Storage all models, -50° to +90°C; Extended temp testing avail.: for UL, -40° to +80°C; for CEN, -50° to +90°C
Shock	50 g's at 11 msec
Vibration	5 to 2000 Hz @ 20 g's
Humidity	100% RH
Hazardous Area Rating	UL listed for use in hazardous locations. Class I, Group D, or Class I, Groups C & D, and Class II, Groups E, F & G. NEMA Enclosure 7.

Notes & Tables: All notes and tables referred to in the text can be found on pages 4 and 5.



DIMENSIONS

Dimensions in inches

H38 WITH UL MODEL OPTION

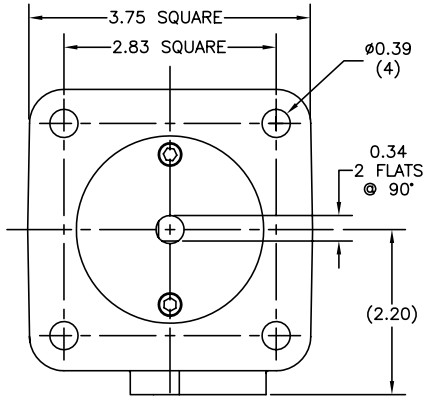

H38 WITH CEN MODEL OPTION

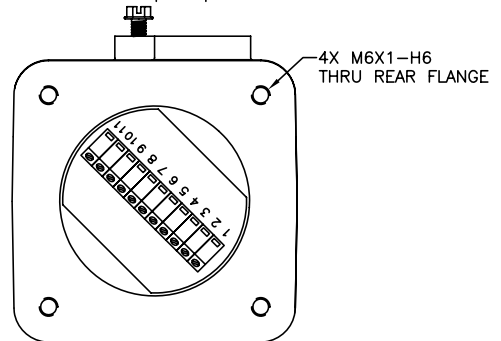
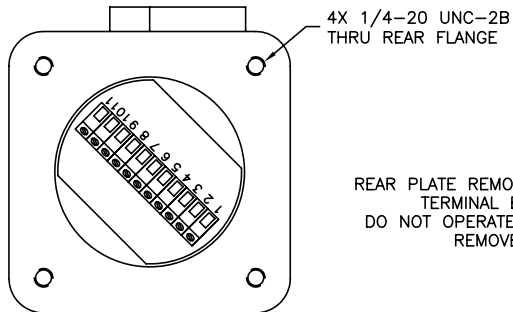
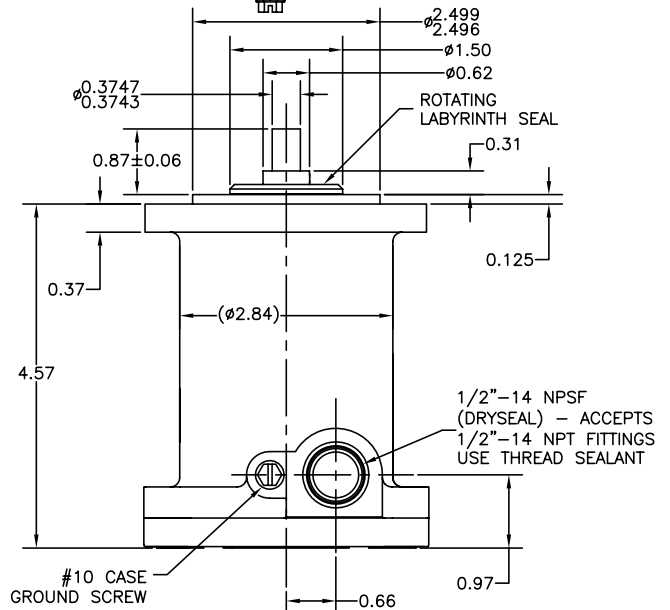
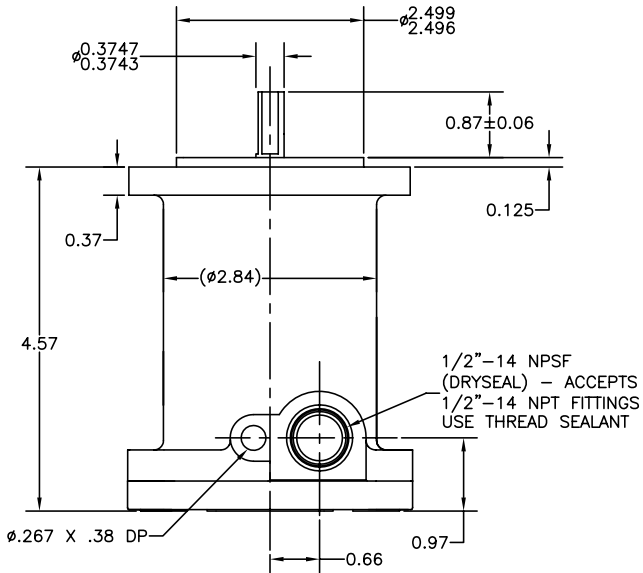
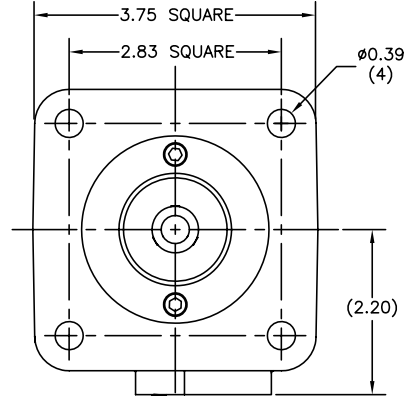

REAR PLATE REMOVED TO SHOW TERMINAL BOARD.
DO NOT OPERATE WITH PLATE REMOVED.

1. Non-standard index widths and multiple indices are available by special order. Consult factory.
2. Complementary outputs are recommended for use with line driver type (source/sink) outputs. When used with differential receivers, this combination provides a high degree of noise immunity.
3. **Output IC's:** Output IC's are available as either Line Driver (LD) or NPN Open Collector (OC) types. Open Collectors require pull-up resistors, resulting in higher output source impedance (sink impedance is similar to that of line drivers). In general, use of a Line Driver style output is recommended. Line Drivers source or sink current and their lower impedance means better noise immunity and faster switching times. **Warning:** Do not connect any line driver outputs directly to circuit common/OV. Those may damage the driver. Unused outputs should be isolated and left floating. Our applications specialists would be pleased to discuss your system requirements and the compatibility of your receiving electronics with Line Driver type outputs.
28V/V: Multi-voltage Line Driver (7272*): 100 mA source/sink. Input voltage 5 to 28 VDC +/- 5% standard (Note: $V_{out} = V_{in}$). This driver is TTL compatible when used with 5 volt supply. Supply lines are protected against overvoltage to 60 volts and reverse voltage. Outputs are short circuit protected for one minute. Supply current is 120 mA typical (plus load current). This is the recommended replacement for 3904R and 7406R open collector outputs with internal pullup resistors. It is also a direct replacement for any 4469, 88C30, 8830 or 26LS31 line driver
28V/5: Multi-voltage Line Driver (7272*): 100 mA source/sink. Input voltage 5 to 28 VDC +/- 5% standard, internally regulated with 5V (TTL compatible) logic out. Supply lines are protected against overvoltage to 60 volts and reverse voltage. Outputs are short circuit protected for one minute. Supply current is 90 mA typical (plus load current).
15V/V: Multi-voltage Line Driver (4469*): 100 mA source/sink. Input voltage 5 to 15 VDC +/- 5% standard (Note: $V_{out} = V_{in}$). TTL compatible when used with 5 volt. Supply lines are protected against overvoltage to 60 volts and reverse voltage. Outputs are short circuit protected for one minute. Supply current is 90 mA typical (plus load current). This is a direct replacement for the 4469 Line Driver.
28V/OC: NPN Open Collector (3904*, 7273*). Current sink of 80 mA max. Current sourced by external pull-up resistor. Output can be pulled up to voltage other than supply voltage (30 V max). Input voltage 5 to 28 VDC +/- 5% standard. Supply current is 120 mA typical. This replaces prior IC's with designations of 3904, 7406, 3302, 681 and 689. 5V/OCR, **15V/OCR, 24V/OCR:** Open Collector (3904R*, 7406R*, 7273R*): Current sink of 70 mA max. Includes internal pull-ups sized at approximately 100 ohms/volt. Max current source is 10 mA. Supply current is 100 mA typical, 120 mA with internal pull-ups. The 5V/OCR, 15V/OCR and 24V/OCR are often replaced by the 28V/V in system upgrades.
4. Special -S at the end of the model number is used to define a variety of non-standard features such as special shaft lengths, voltage options, or special testing. Please consult the factory to discuss your special requirements.
5. Higher frequency response may be available. Please consult with the factory.
6. Extended temperature ratings are available. Consult with factory for more specific information.
7. For interpolation options, contact factory. See Doc. 01059-000 supplied with encoders for Important Installation and Usage notes summarized here.

Encoder Installation

1. Environment: Hazardous Locations — **UL** Complies with UL and cUL requirements; **CEN** Shall comply with UL requirements plus CENELAC/ATEX plus IECEx standards
2. WARNING: Open all circuits prior to connecting this product to power and controller.
3. The installation must comply with NEC Class 2 circuits or with the regulations of the country of use.
4. AWG 14 - 22 stranded wire stripped to .25" [6.3mm] is recommended.
5. Use agency approved 105° C minimum rated cable/conductors housed within an approved rigid conduit.
6. Conduit runs must have a sealing fitting certified to 60079-0 Ex d IIB immediately at the entrance to the device.
7. Tightly close terminal block access cover prior to applying power.
8. For maximum bearing life, a flexible coupling is recommended between encoder shaft and driving shaft.
9. Thread sealant compound should be used for 1/2-14 fitting or cable gland to prevent ingress of contamination.

During Use

1. Keep terminal block access tightly secured during use.
2. DO NOT loosen two 5/16" set screws at opposite face.

Maintenance and Service

1. There are no user serviceable parts inside. Encoder must be returned to factory for service.
2. WARNING: Open all circuits to this product prior to opening access cover to disconnect wires.

Table 1 - Output Terminations	
Terminal Pin No.	Ouput
1	CASE GROUND
2	0V
3	+V
4	A
5	B
6	Z
7	\bar{A}
8	\bar{B}
9	\bar{Z}
10	SPARE
11	SPARE

Table 2 –Disc Resolutions for Incremental Encoder Model H38
1, 2, 3, 5, 6, 7, 8, 10, 13, 16, 20, 24, 25, 26, 30, 32, 33, 34, 36, 37, 40, 45, 48, 50, 51, 56*, 60, 64, 66, 72, 75, 80, 86, 88, 90, 100, 102, 120, 122, 125, 127, 128, 132, 144, 148, 150, 158, 160, 175, 176, 180, 187, 192, 200, 202, 204*, 217, 220, 240, 250, 254, 255, 256, 264*, 274, 280, 283, 288, 292, 300, 312, 320, 321, 325, 360, 366, 372, 375, 377, 380, 381, 384, 385, 393, 400, 430, 432, 450, 462, 480, 490, 500, 502, 508, 512, 522, 530, 550, 560*, 576, 598, 600, 604, 625, 628, 635, 638, 640, 660, 672, 676, 680, 687, 690, 700, 720, 725, 735, 740, 744, 748, 750, 762, 768, 780, 785, 800, 812, 825, 850, 864, 878, 888, 900, 912, 914, 938, 942, 955, 960, 1000, 1016, 1024, 1030, 1035, 1036, 1040, 1054, 1056, 1074, 1076, 1080, 1088, 1100, 1101, 1125, 1136, 1200, 1237, 1250, 1257, 1270, 1280, 1300, 1314, 1332, 1333, 1390, 1400, 1414, 1427, 1440, 1484, 1500, 1562, 1570, 1596, 1600, 1650, 1666, 1718, 1745, 1774, 1800, 1840*, 1850, 1855, 1875, 1894, 1920, 1952, 1968, 1979, 1995, 2000, 2048, 2080, 2094, 2100, 2160, 2164, 2199, 2200, 2250, 2356, 2400, 2485, 2500, 2514, 2519, 2540, 3000, 3125, 3600, 4000, 4096, 5000

*AB or ABC output only.

NOTE: Resolutions up to 72,000 are available. See Note 7.



H38 **D** - **2000** - **ABZ** **C** - **28V/V** - **SC** - **CEN** -

Type
H = Heavy Duty;
38 = 3.75" Square

Housing Configuration
D = Standard (see dimensions, page 3)

Cycles Per Turn
 Enter Cycles, See Table 2

No. of Channels
A = Single Channel
AB = Dual Quad. Ch.
ABZ = Dual with Index
AZ = Single with Index
 See note 1

Complements
C = Complementary Outputs,
Blank = None
 See note 2

Voltage/Output
15V/V = 5-15 V_{in/out}
28V/V = 5-28V_{in/out}
28V/5 = 5-28V_{in} /5V_{out}
28V/OC = 5-28V_{in} /OC_{out}
 See note 3

Output Termination
SC = Side Conduit, 1/2-14 NPSF (dryseal) straight pipe threads Accepts both NPS and NPT Type fittings

Certification
UL = Class I Group D Environments
CEN = UL, Cenelec, IECEx
MSHA = Mine Safety and Health Administration Certified

Special Features
S = Special features specified on purchase order (consult factory)
 See note 4

AGENCY APPROVALS & CERTIFICATIONS

 EN 61000-6-4 and EN 61000-6-2



II 2 G Ex d IIB T4 Gb



Class I, Group C & D;
Class II Group E, F & G;



Ex d IIB T4 Gb
IECEx UL 14.0006X



The Mine Safety and Health Administration (MSHA) is an organization that operates in the United States and enforces compliance with safety and health standards in the Nation's mines. Consult factory for MSHA rated product.

Sensata Technologies, Inc. ("Sensata") data sheets are solely intended to assist designers ("Buyers") who are developing systems that incorporate Sensata products (also referred to herein as "components"). Buyer understands and agrees that Buyer remains responsible for using its independent analysis, evaluation and judgment in designing Buyer's systems and products. Sensata data sheets have been created using standard laboratory conditions and engineering practices. Sensata has not conducted any testing other than that specifically described in the published documentation for a particular data sheet. Sensata may make corrections, enhancements, improvements and other changes to its data sheets or components without notice.

Buyers are authorized to use Sensata data sheets with the Sensata component(s) identified in each particular data sheet. HOWEVER, NO OTHER LICENSE, EXPRESS OR IMPLIED, BY ESTOPPEL OR OTHERWISE TO ANY OTHER SENSATA INTELLECTUAL PROPERTY RIGHT, AND NO LICENSE TO ANY THIRD PARTY TECHNOLOGY OR INTELLECTUAL PROPERTY RIGHT, IS GRANTED HEREIN. SENSATA DATA SHEETS ARE PROVIDED "AS IS". SENSATA MAKES NO WARRANTIES OR REPRESENTATIONS WITH REGARD TO THE DATA SHEETS OR USE OF THE DATA SHEETS, EXPRESS, IMPLIED OR STATUTORY, INCLUDING ACCURACY OR COMPLETENESS. SENSATA DISCLAIMS ANY WARRANTY OF TITLE AND ANY IMPLIED WARRANTIES OF MERCHANTABILITY, FITNESS FOR A PARTICULAR PURPOSE, QUIET ENJOYMENT, QUIET POSSESSION, AND NON-INFRINGEMENT OF ANY THIRD PARTY INTELLECTUAL PROPERTY RIGHTS WITH REGARD TO SENSATA DATA SHEETS OR USE THEREOF.

All products are sold subject to Sensata's terms and conditions of sale supplied at www.sensata.com SENSATA ASSUMES NO LIABILITY FOR APPLICATIONS ASSISTANCE OR THE DESIGN OF BUYERS' PRODUCTS. BUYER ACKNOWLEDGES AND AGREES THAT IT IS SOLELY RESPONSIBLE FOR COMPLIANCE WITH ALL LEGAL, REGULATORY AND SAFETY-RELATED REQUIREMENTS CONCERNING ITS PRODUCTS, AND ANY USE OF SENSATA COMPONENTS IN ITS APPLICATIONS, NOTWITHSTANDING ANY APPLICATIONS-RELATED INFORMATION OR SUPPORT THAT MAY BE PROVIDED BY SENSATA.

Mailing Address: Sensata Technologies, Inc., 529 Pleasant Street, Attleboro, MA 02703, USA.

CONTACT US

Americas

+1 (800) 350 2727 – Option 1
sales.beisensors@sensata.com
Europe, Middle East & Africa
+33 (3) 88 20 8080
position-info.eu@sensata.com

Asia Pacific

sales.isasia@list.sensata.com
China +86 (21) 2306 1500
Japan +81 (45) 277 7117
Korea +82 (31) 601 2004
India +91 (80) 67920890
Rest of Asia +886 (2) 27602006
ext 2808

X-ON Electronics

Largest Supplier of Electrical and Electronic Components

Click to view similar products for [Encoders](#) category:

Click to view products by [BEI Sensors](#) manufacturer:

Other Similar products are found below :

[6-1393048-5](#) [62AG22-H5-P](#) [62B22-LP-030C](#) [62D22-02-P](#) [62R22-01-040S](#) [63K25](#) [63K32](#) [63KS100](#) [63KS64](#) [63R100](#) [63R50-020](#) [63RS256-060](#) [700-09-36](#) [E6C2-CWZ6C-10 500P/R 5M](#) [E6C3-CWZ5GH 1000P/R 2M](#) [25LB22-G-Z](#) [T101-5C2-111-M1](#) [T101-5C3-111-M1](#) [T101-5C4-111-M1](#) [25LB45-Q-Z](#) [HEDS-8905](#) [385001M0439](#) [385001M0216](#) [DPL12SV2424A25K3](#) [E69-1](#) [E69-DF15](#) [E69-FBA-02](#) [E69-FCA](#) [E6B2-CWZ1X 2000P/R 0.5M](#) [E6B2-CWZ3E 600P/R 0.5M](#) [E6C3-CWZ3EH 800P/R 2M](#) [ENA1D-472-L00050L](#) [61S64-2](#) [62B11-LP-100S](#) [62B11-LPP-P](#) [62C1111-02-020C](#) [62N11-P](#) [62S22-H9-120S](#) [62S30-L0-200C](#) [62V15-02-080S](#) [62V22-02-030C](#) [632911-128](#) [63K64](#) [63KS100-040](#) [63R64-050](#) [63RS256](#) [63RS64](#) [700-16-16](#) [3-1393048-1](#) [63KS128](#)