

THE INFORMATION CONTAINED HEREIN IS CONSIDERED "PROPRIETARY" TO BEL FUSE INC. AND SHALL NOT BE COPIED, REPRODUCED OR DISCLOSED WITHOUT THE WRITTEN APPROVAL OF BEL FUSE INC.

LED1 POLARITY			LED2 POLARITY		
PIN 13	PIN 14	COLOR	PIN 15	PIN 16	COLOR
-	+	YELLOW	+	-	ORANGE
			-	+	GREEN

RoHS



ELECTRICAL CHARACTERISTICS @ 25°C

URNS RATIO

TP1	1CT : 1CT ±2%
TP2	1CT : 1CT ±2%
TP3	1CT : 1CT ±2%
TP4	1CT : 1CT ±2%

□CL @ 100kHz/100mVRMS

8mA DC BIAS	350µH MIN.
INS. LOSS	
0.1MHz TO 1MHz	-1.1 dB MAX
1MHz TO 65MHz	-0.5 dB MAX
65MHz TO 100MHz	-0.8 dB MAX
100MHz TO 125MHz	-1.2 dB MAX

RET. LOSS (MIN)

0.5MHz-40MHz	-18 dB
40MHz-100MHz	-12+20LOG(f/80MHz) dB

CM TO CM REJ

100kHz - 100MHz	-30 dB MIN
-----------------	------------

CM TO DM REJ

100kHz - 100MHz	-35 dB MIN
-----------------	------------

HIPOT (Isolation Voltage): 1500 Vrms
100% OF PRODUCTION TESTED TO COMPLY WITH IEEE 802.3 ISOLATION REQUIREMENTS.

OPERATING TEMPERATURE: -40°C TO +85°C

LED 1

VF (FORWARD VOLTAGE)	IF=20mA	YELLOW	2.1V TYP.
λD (DOMINANT WAVELENGTH)	IF=20mA	YELLOW	590nm TYP.

LED 2

VF (FORWARD VOLTAGE)	IF=20mA	GREEN	2.2V TYP.
		ORANGE	2.0V TYP.
λD (DOMINANT WAVELENGTH)	IF=20mA	GREEN	570nm TYP.
		ORANGE	605nm TYP.

USB ELECTRICAL:

INSULATION RESISTANCE:	1000 MEGA (MIN)
CONTACT RESISTANCE:	25 MILLI Ω (MAX)
DIELECTRIC WITHSTANDING:	750 VAC

SCHEMATIC

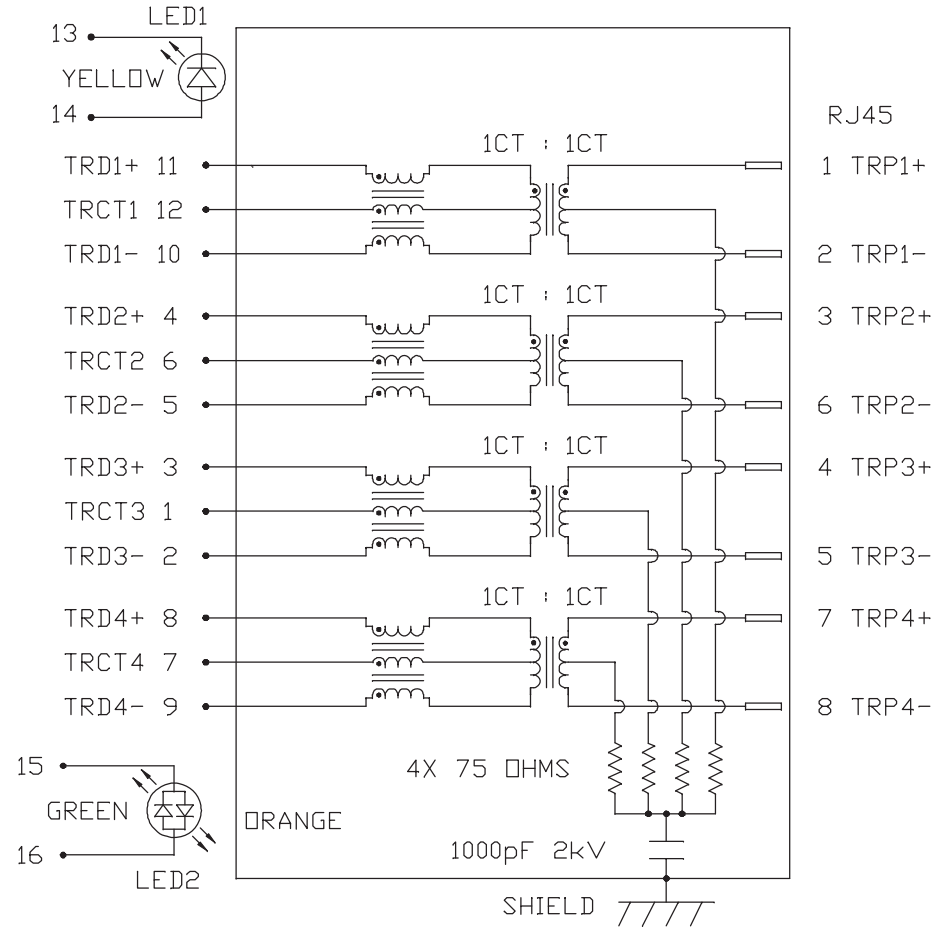

ORIGINATED BY
CHOW WANCHUNG
DATE 2015-10-13

TITLE
gigabit MagJack® Combo
(Single USB)
Extended temperature
0821-1X1T-32-F
PATENTED

PART NO. / DRAWING NO.
08211X1T32-F

FILE NAME
08211X1T32-F_C.DWG

STANDARD DIM.
TOL. IN INCH
[] METRIC DIM.
AS REF.
UNIT : INCH [mm]
SCALE : N/A
SIZE : A4

REV. : C PAGE : 2



THE INFORMATION CONTAINED HEREIN IS CONSIDERED "PROPRIETARY" TO BEL FUSE INC. AND SHALL NOT BE COPIED, REPRODUCED OR DISCLOSED WITHOUT THE WRITTEN APPROVAL OF BEL FUSE INC.

RoHS



MECHANICAL SPECIFICATION

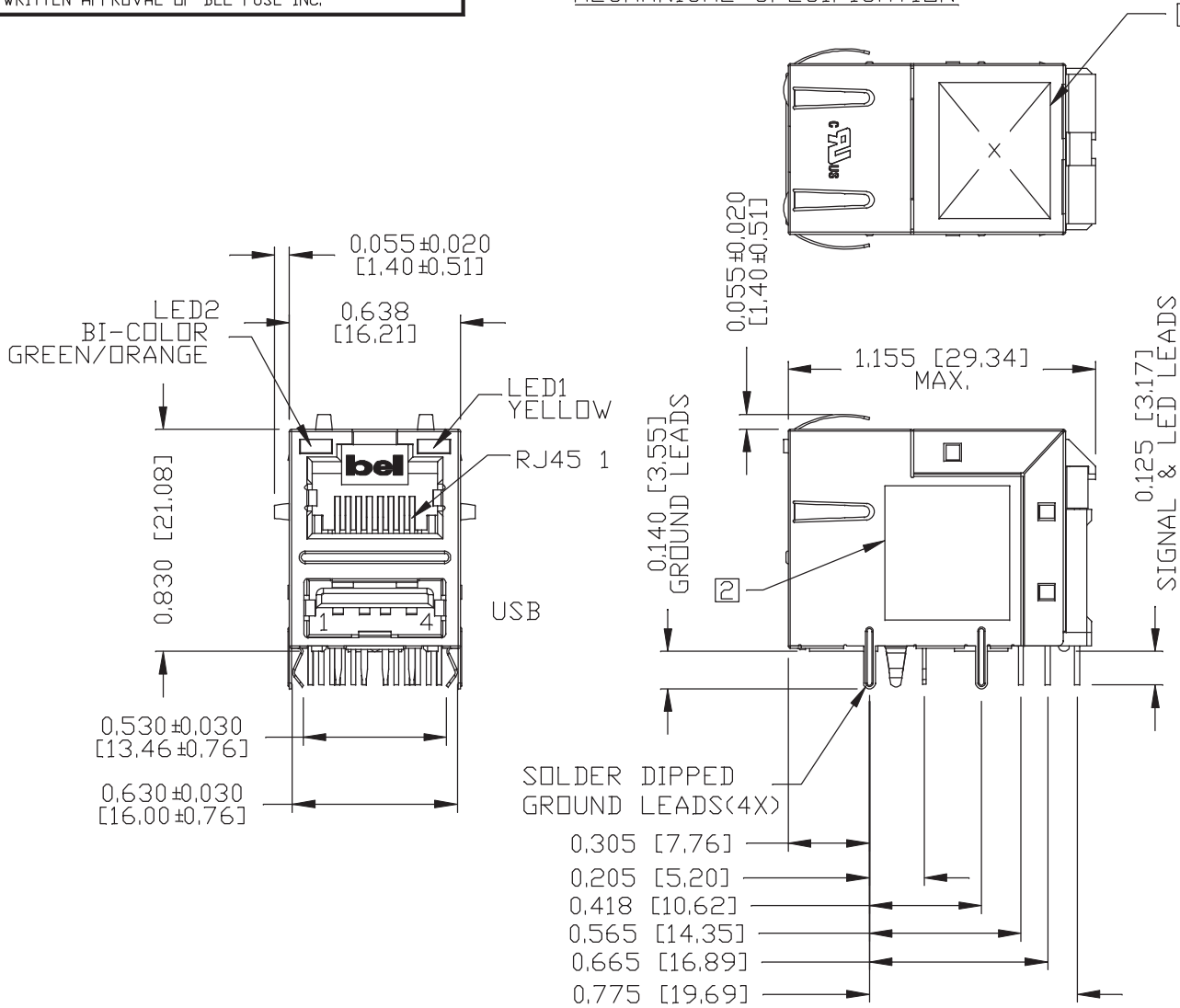

RJ45 MECHANICAL:

PLASTIC HOUSING: THERMOPLASTIC PBT
 FLAMMABILITY RATING UL 94V-0
 CONTACT PLATING: 30 MICRO-INCH HARD GOLD PLATING OR EQUIVALENT,
 PINS: TIN-COATED COPPER WIRE, DIA 0.018 INCH.
 METAL SHIELD: NICKEL PLATED ON COPPER ALLOY, (ALL GROUND LEADS ARE SOLDER DIPPED)

USB MECHANICAL:

MATING FORCE: 35 NEWTONS MAXIMUM
 UNMATING FORCE: 10 NEWTONS MINIMUM
 CONTACT: PROSPHER BRONZE
 30 MICRO-INCH MIN GOLD PLATING ON CONTACT AREA AND TIN ON SOLDER TAIL.

① MARK PART WITH MFG. LOGO, MFG. NAME, PART NUMBER AND DATE CODE.

UL RECOGNIZED - FILE #E196366 AND E169987.

② MARKING "PATENTED".

3. THE PRODUCT IS RoHS COMPLIANT.

4. THE PRODUCT IS PATENTED, THE PATENT NUMBER IS U.S. PAT. 7,123,117.

ORIGINATED BY
ANTON LIAO
DATE 2015-10-13
DRAWN BY
JESSE LI
DATE 2015-10-13

TITLE
gigabit MagJack® Combo (Single USB)
Extended temperature
0821-1X1T-32-F
PATENTED

PART NO. / DRAWING NO.
08211X1T32-F
FILE NAME
08211X1T32-F_C.DWG

STANDARD DIM. TOL. IN INCH		[] METRIC DIM. AS REF.
.X		UNIT : INCH [mm]
.XX		SCALE : N/A
.XXX	±0.010	SIZE : A4

REV. : C PAGE : 3



THE INFORMATION CONTAINED HEREIN IS CONSIDERED "PROPRIETARY" TO BEL FUSE INC. AND SHALL NOT BE COPIED, REPRODUCED OR DISCLOSED WITHOUT THE WRITTEN APPROVAL OF BEL FUSE INC.

RoHS



RECOMMENDED PCB FOOTPRINT
COMPONENT SIDE VIEW

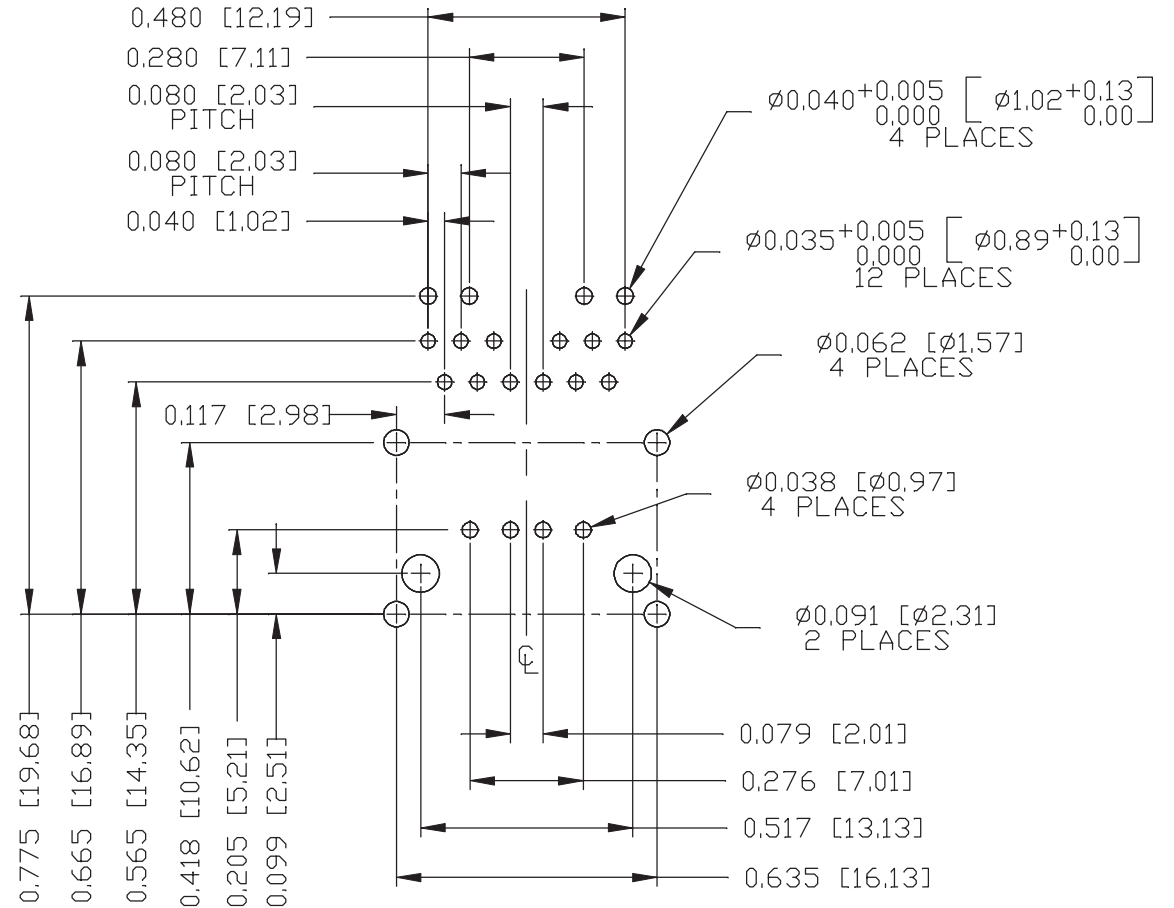
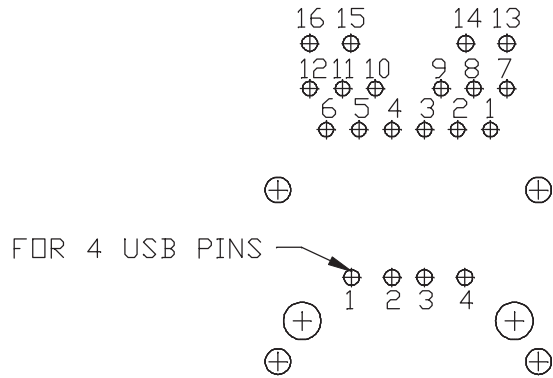

REV. : C PAGE : 4

ORIGINATED BY
ANTON LIAO
DATE 2015-10-13
DRAWN BY
JESSE LI
DATE 2015-10-13

TITLE
gigabit MagJack® Combo
(Single USB)
Extended temperature
0821-1X1T-32-F
PATENTED

PART NO. / DRAWING NO.
08211X1T32-F
FILE NAME
08211X1T32-F_C.DWG

STANDARD DIM. TOL. IN INCH		[] METRIC DIM. AS REF.
.X		UNIT : INCH [mm]
.XX		SCALE : N/A
.XXX	±0.004	SIZE : A4



THE INFORMATION CONTAINED HEREIN IS CONSIDERED "PROPRIETARY" TO BEL FUSE INC. AND SHALL NOT BE COPIED, REPRODUCED OR DISCLOSED WITHOUT THE WRITTEN APPROVAL OF BEL FUSE INC.

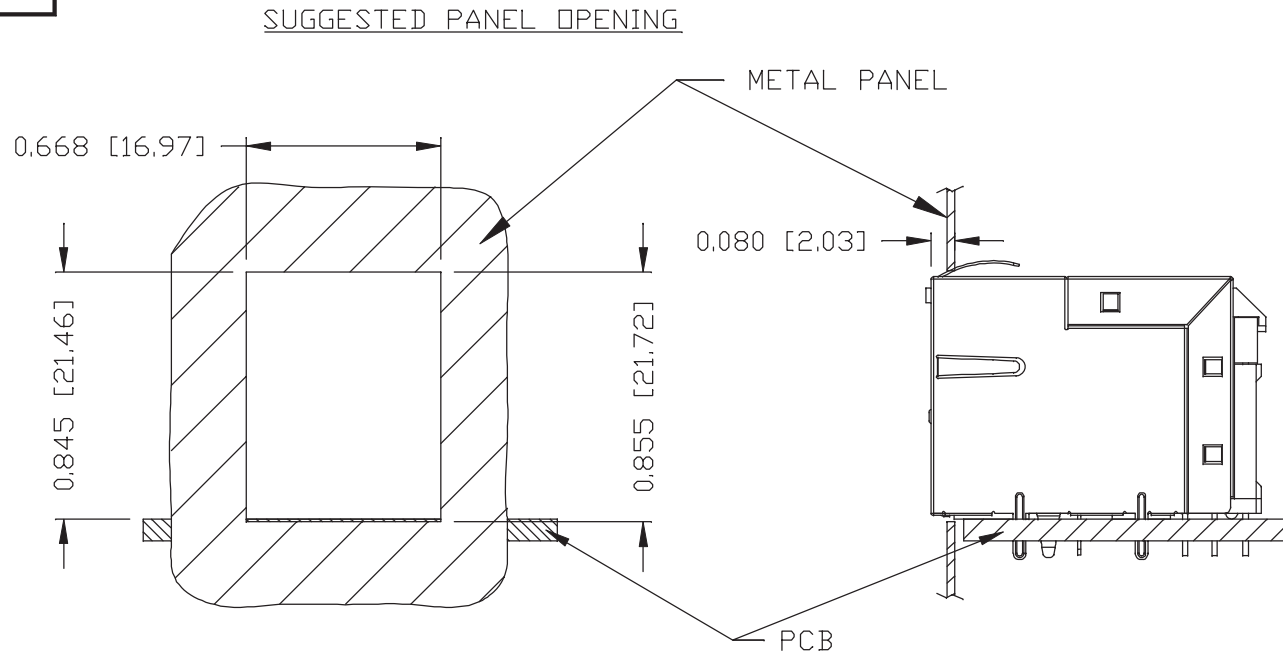

NOTES:

THE DISTANCE OF PANEL INSIDE SURFACE RELATIVE TO FRONT SURFACE OF PART IS ONLY A SUGGESTION. IN CASE THIS DISTANCE IS DIFFERENT, THE REQUIRED PANEL OPENING DIMENSIONS CHANGE ACCORDINGLY.

PACKING INFORMATION

PACKING TRAY : 0200-0148-48 (TOP)
0200-0148-49 (BOTTOM)

PACKING QUANTITY : 60 PCS FINISHED GOODS PER TRAY
8 TRAYS (480 PCS FINISHED GOODS) PER CARTON BOX

NOTE : CARDBOARDS ARE PLACED BETWEEN LAYERS OF PACKING TRAY INSIDE CARTON BOX
(INCLUDE THE UPPERMOST AND LOWERMOST TRAY)

REV. :	C	PAGE :	5
--------	---	--------	---

ORIGINATED BY ANTON LIAO
DATE 2015-10-13
DRAWN BY JESSE LI
DATE 2015-10-13

TITLE gigabit MagJack® Combo (Single USB) Extended temperature 0821-1X1T-32-F PATENTED

PART NO. / DRAWING NO. 08211X1T32-F
FILE NAME 08211X1T32-F_C.DWG

STANDARD DIM. TOL. IN INCH	[] METRIC DIM. AS REF.
.X	UNIT : INCH [mm]
.XX	SCALE : N/A
.XXX ±0.004	SIZE : A4



X-ON Electronics

Largest Supplier of Electrical and Electronic Components

Click to view similar products for [Modular Connectors / Ethernet Connectors](#) category:

Click to view products by [Bel Fuse](#) manufacturer:

Other Similar products are found below :

[8949-H88/06BLKA/SN](#) [74441-0010/BKN](#) [MP1010RX-1000](#) [MP44RX-1000](#) [PHJ-4P4C-1-V-4](#) [PHP-6P6C-5](#) [GAX-3-66](#) [GAX-8-62](#) [GDCX-PA-66-50](#) [GDCX-PN-64](#) [GDCX-PN-66](#) [GDCX-PN-66-50](#) [GDLX-A-66](#) [GDLX-N-66](#) [GDLX-S-66](#) [GDLX-S-88K](#) [GDLX-SMT-S-88](#) [GDTX-S-88-50](#) [GDX-PA-1010](#) [GLX-N-1010M-BLK](#) [GLX-S-88M-BLK](#) [GMX-N-1010](#) [GMX-S-1010](#) [GMX-S-66](#) [GMX-SMT4-N-88](#) [GPX-2-64](#) [GSGX-N-2-88](#) [GSGX-N-4-88](#) [GSX-NS2-88-3.05](#) [GSX-NS2-88-3.05-50](#) [GSX-NS-88-3.05-50](#) [PT-108A-8C-UL](#) [PT-J951-8C](#) [PTS-J531-8CS-50UL](#) [1-1775629-2](#) [A-2014-0-4](#) [GWLX-S-88-GR](#) [GWLX-S9-88-YG](#) [DC-1021-8-WH-6](#) [1300530003](#) [1324640-4](#) [RJ11FTVC2G](#) [RJ11FTVC2N](#) [RJFTVX2SA1G](#) [132764-001](#) [1413235](#) [MP88X-1000](#) [MPS88RX-5000](#) [E5288-S000K3-L](#) [E5908-15A242-L](#)