

THE INFORMATION CONTAINED HEREIN IS CONSIDERED "PROPRIETARY" TO BEL FUSE INC. AND SHALL NOT BE COPIED, REPRODUCED OR DISCLOSED WITHOUT THE WRITTEN APPROVAL OF BEL FUSE INC.



ELECTRICAL CHARACTERISTICS @ 25°C

URNS RATIO

| | |
|-----|---------------|
| TP1 | 1CT : 1CT ±2% |
| TP2 | 1CT : 1CT ±2% |
| TP3 | 1CT : 1CT ±2% |
| TP4 | 1CT : 1CT ±2% |

OCL @ 100kHz/100mVRMS

8mA DC BIAS 350µH MIN.

INS. LOSS

| | |
|------------------|-------------|
| 0.1MHz TO 1MHz | -1.1 dB MAX |
| 1MHz TO 65MHz | -0.5 dB MAX |
| 65MHz TO 100MHz | -0.8 dB MAX |
| 100MHz TO 125MHz | -1.2 dB MAX |

RET. LOSS (MIN)

| | |
|--------------|-----------------------|
| 0.5MHz-40MHz | -18 dB |
| 40MHz-100MHz | -12+20LOG(f/80MHz) dB |

CM TO CM REJ

100kHz - 100MHz -30 dB MIN

CM TO DM REJ

100kHz - 100MHz -35 dB MIN

HIPOT (Isolation Voltage): 1500 Vrms or 2250VDC

SCHEMATIC

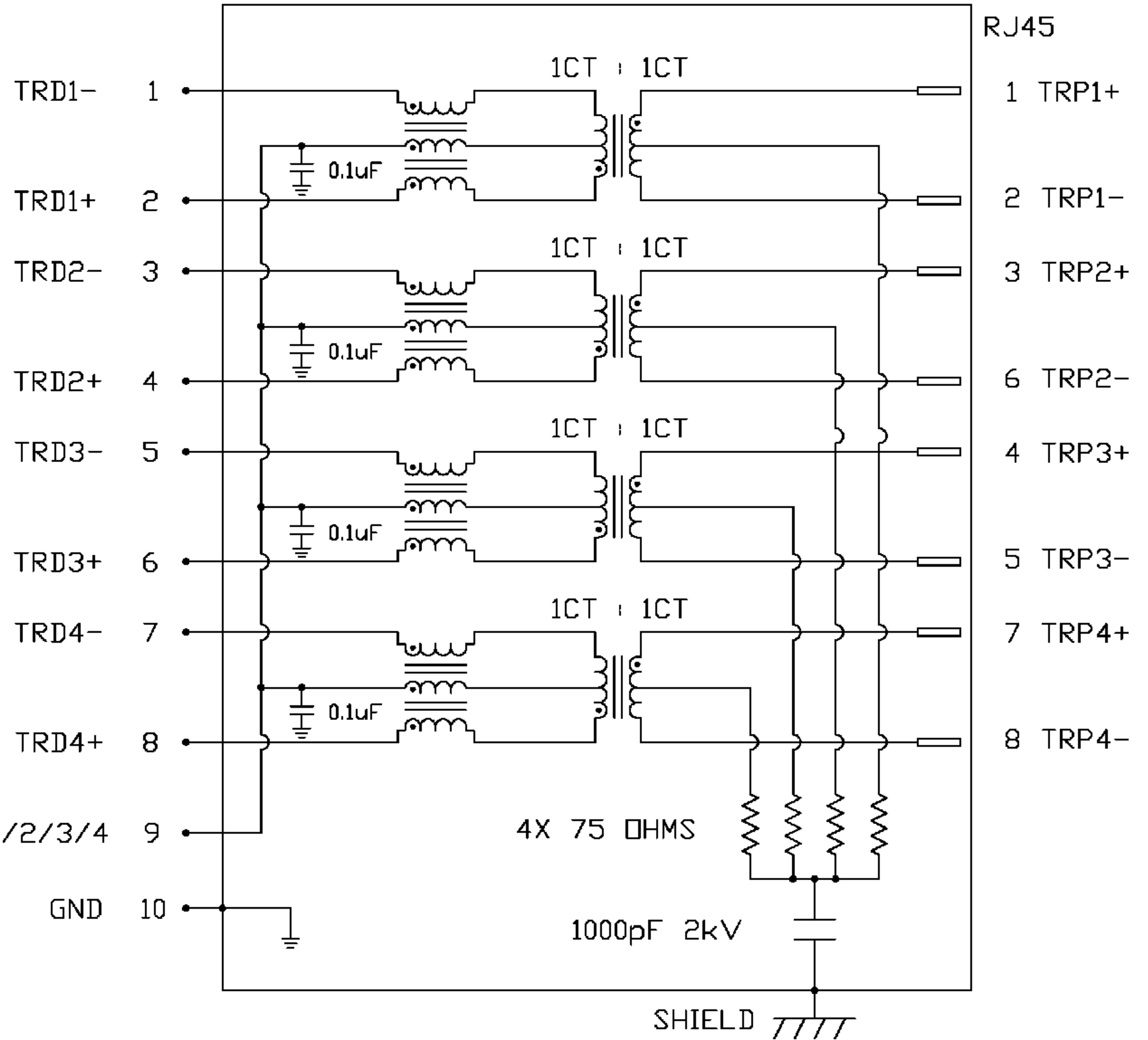

| | | | | | | | |
|---------------|----------|-----------------------------------|------------------------|----------------------------|------------------------------|---------------------------------------|-----------|
| ORIGINATED BY | DATE | TITLE | PART NO. / DRAWING NO. | STANDARD DIM. TOL. IN INCH | [] METRIC DIM. AS REFERENCE | COMPONENTS FOR A CONNECTED PLANET | |
| CHUNG | 03-21-06 | 2X4 gigabit MagJack® (8 Cores) | 08332X4R54-F | .X | UNIT : INCH [mm] | | REV. : B |
| DRAWN BY | DATE | | FILE NAME | .XX | SCALE : N/A | | SIZE : A4 |
| DE | 03-21-06 | 0833-2X4R-54-F | 08332X4R54-FB.DWG | .XXX | PAGE : 2 | | |

THE INFORMATION CONTAINED HEREIN IS CONSIDERED "PROPRIETARY" TO BEL FUSE INC. AND SHALL NOT BE COPIED, REPRODUCED OR DISCLOSED WITHOUT THE WRITTEN APPROVAL OF BEL FUSE INC.

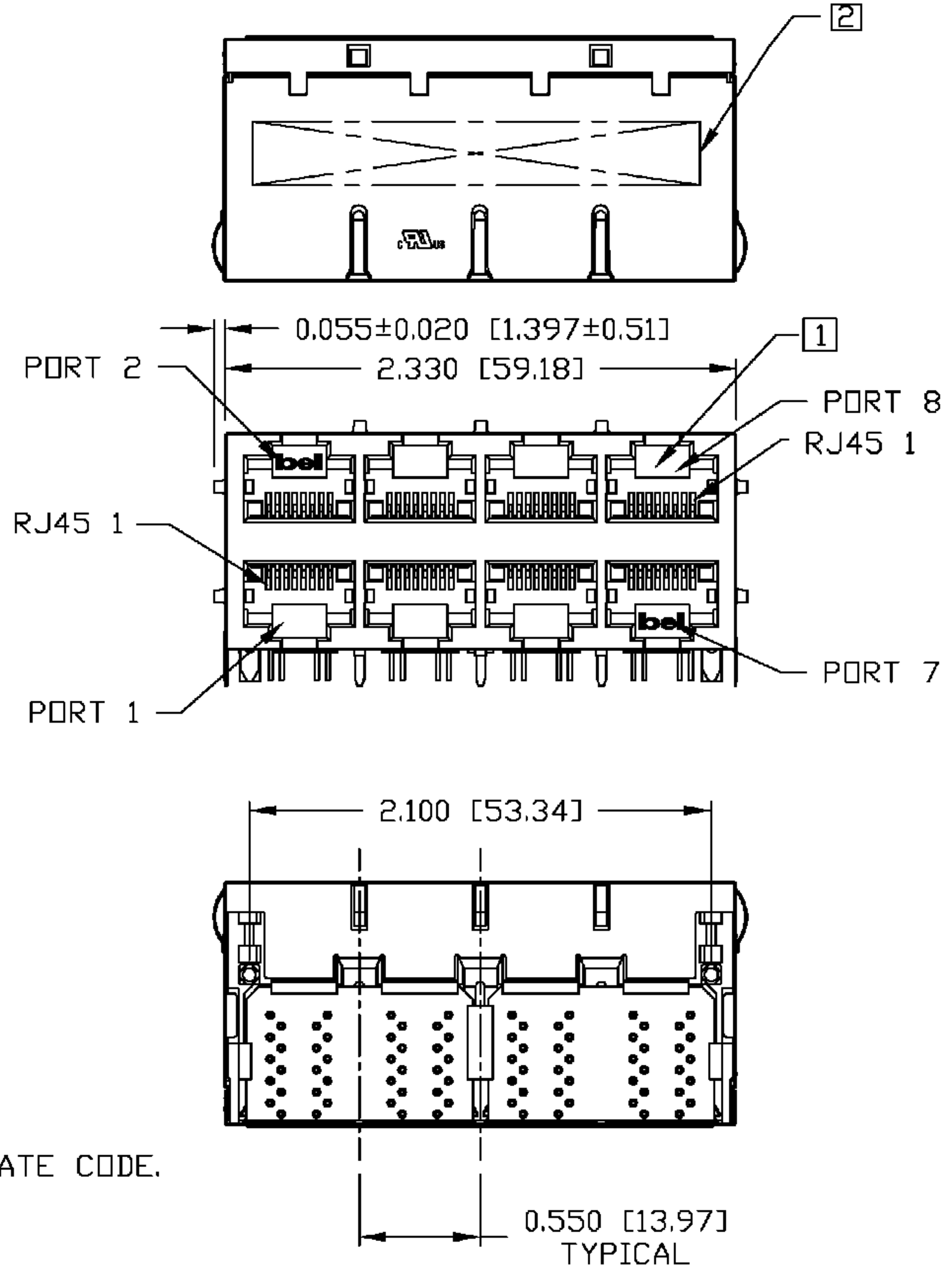
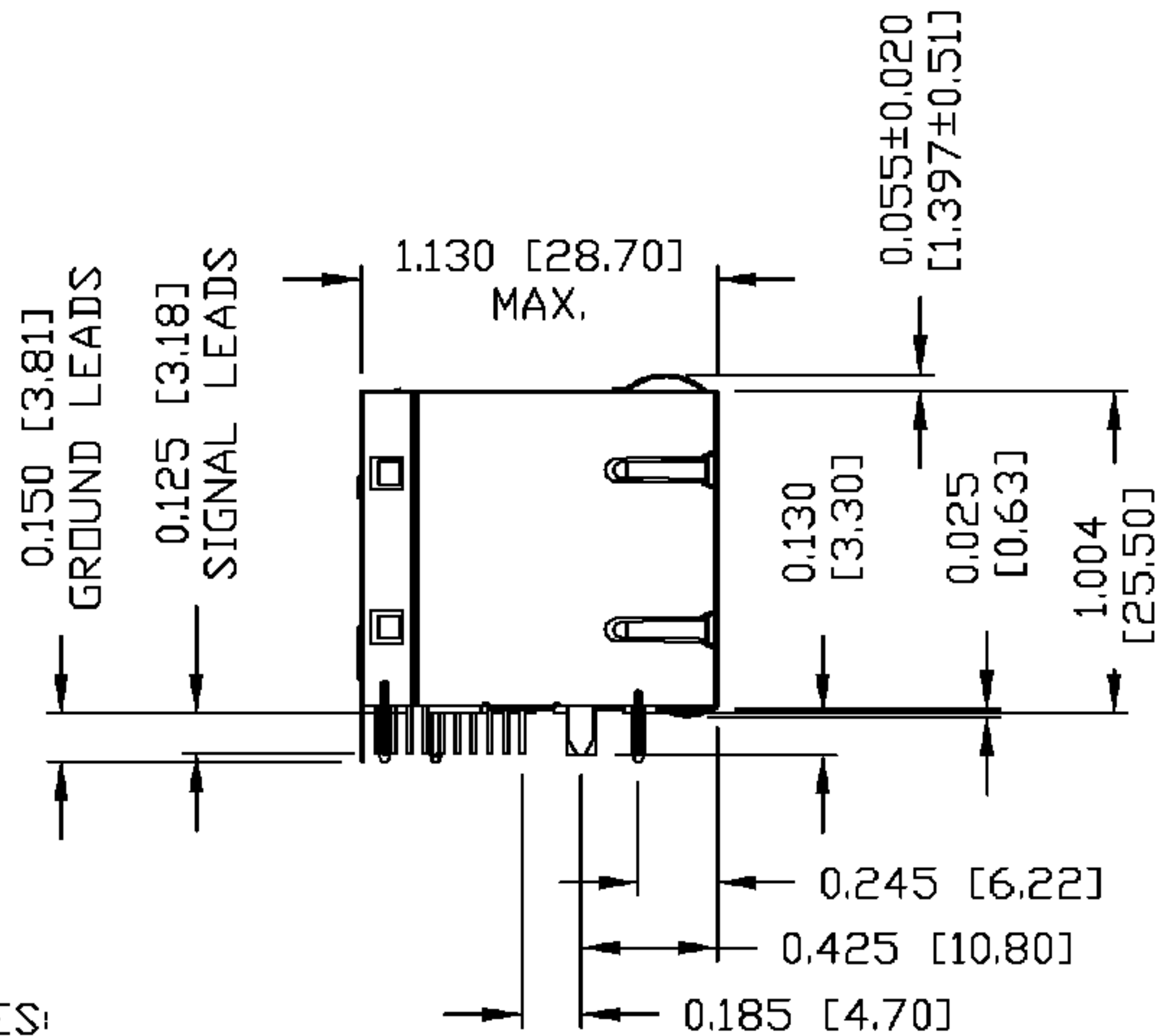

NOTES:

- PLASTIC HOUSING: THERMOPLASTIC PBT
FLAMMABILITY RATING UL 94V-0
- CONTACT PLATING: 50 MICRO-INCH HARD GOLD PLATING
- OUTPUT PINS: TIN-COATED COPPER WIRE, DIA 0.018 INCH.
- METAL SHIELD: NICKEL PLATED ON COPPER ALLOY.
(ALL GROUND LEADS ARE SOLDER DIPPED)

- [1] JACK CAVITY CONFORMS TO FCC RULES AND REGULATIONS, PART 68 SUBPART F.
- [2] MARK PART WITH MFG LOGO, MFG NAME, PART NUMBER, AND DATE CODE.

UL UL RECOGNIZED - FILE #E196366 AND E169987.
RoHS COMPLIANT, PER EU DIRECTIVE 2002/95/EC.

| | | | | | | | | |
|----------------------------|--|--|--|------------------|----------|------------------------------|--|---|
| ORIGINATED BY QIN/KEUNG | DATE 03-21-06 | TITLE 2X4 gigabit MagJack® (8 Cores) 0833-2X4R-54-F | PART NO. / DRAWING NO. 08332X4R54-F | STANDARD DIM. | | [] METRIC DIM. AS REFERENCE | | COMPONENTS FOR A CONNECTED PLANET |
| | TOL. IN INCH .X .XX .XXX ±0.010 | | | UNIT : INCH [mm] | REV. : B | | | |
| DRAWN BY LING | DATE 03-21-06 | FILE NAME 08332X4R54-FB.DWG | SCALE : N/A | SIZE : A4 | | | | |
| | | | | PAGE : 3 | | | | |

THE INFORMATION CONTAINED HEREIN IS CONSIDERED "PROPRIETARY" TO BEL FUSE INC. AND SHALL NOT BE COPIED, REPRODUCED OR DISCLOSED WITHOUT THE WRITTEN APPROVAL OF BEL FUSE INC.

RoHS
2002/95/EC

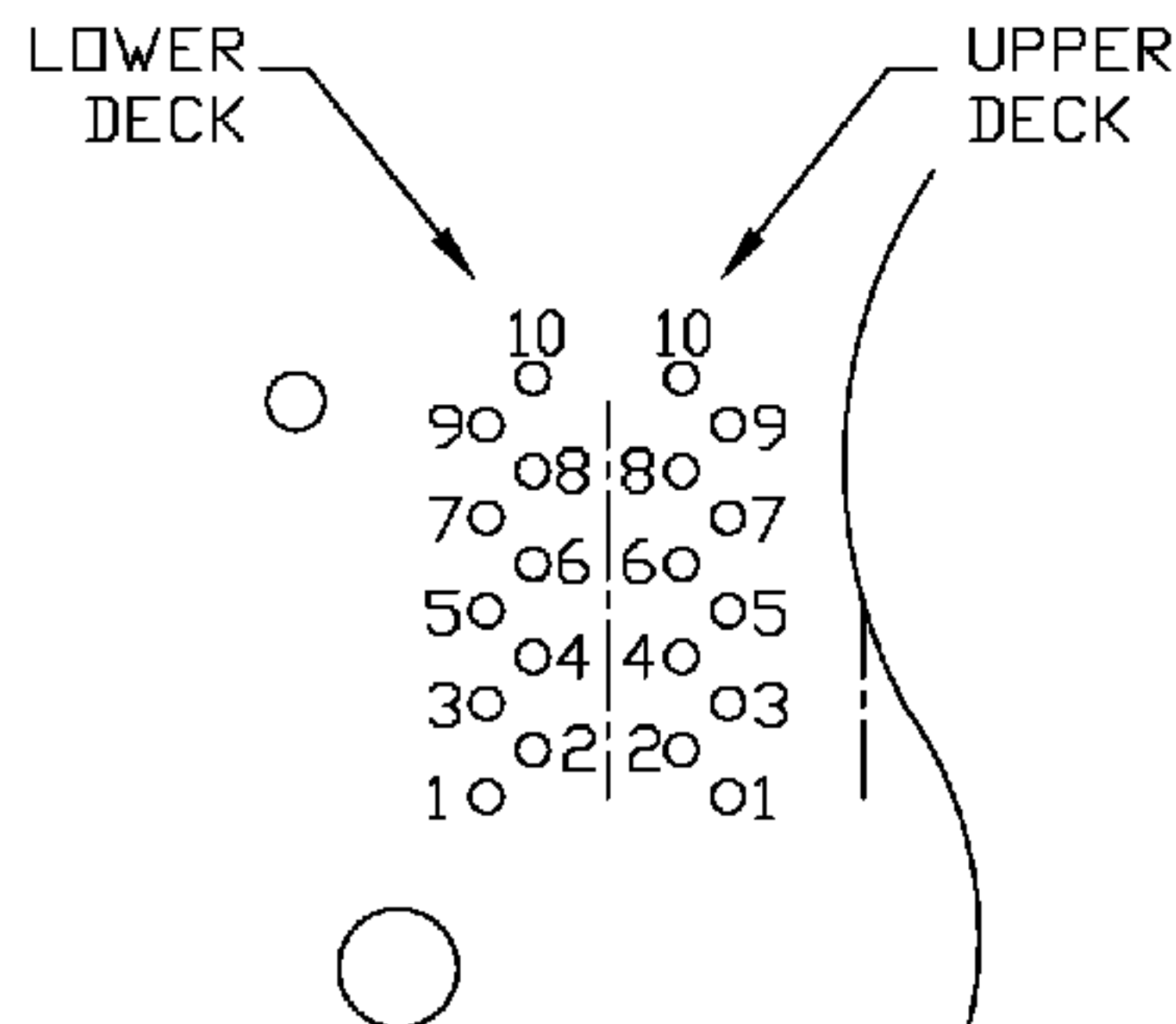

PIN-OUT INFORMATION
(COMPONENT SIDE VIEW)

| | |
|----|--------------|
| 10 | GND |
| 9 | TRDCT1/2/3/4 |
| 8 | TRD 4+ |
| 7 | TRD 4- |
| 6 | TRD 3+ |
| 5 | TRD 3- |
| 4 | TRD 2+ |
| 3 | TRD 2- |
| 2 | TRD 1+ |
| 1 | TRD 1- |

PORT ASSIGNMENT
(COMPONENT SIDE VIEW)

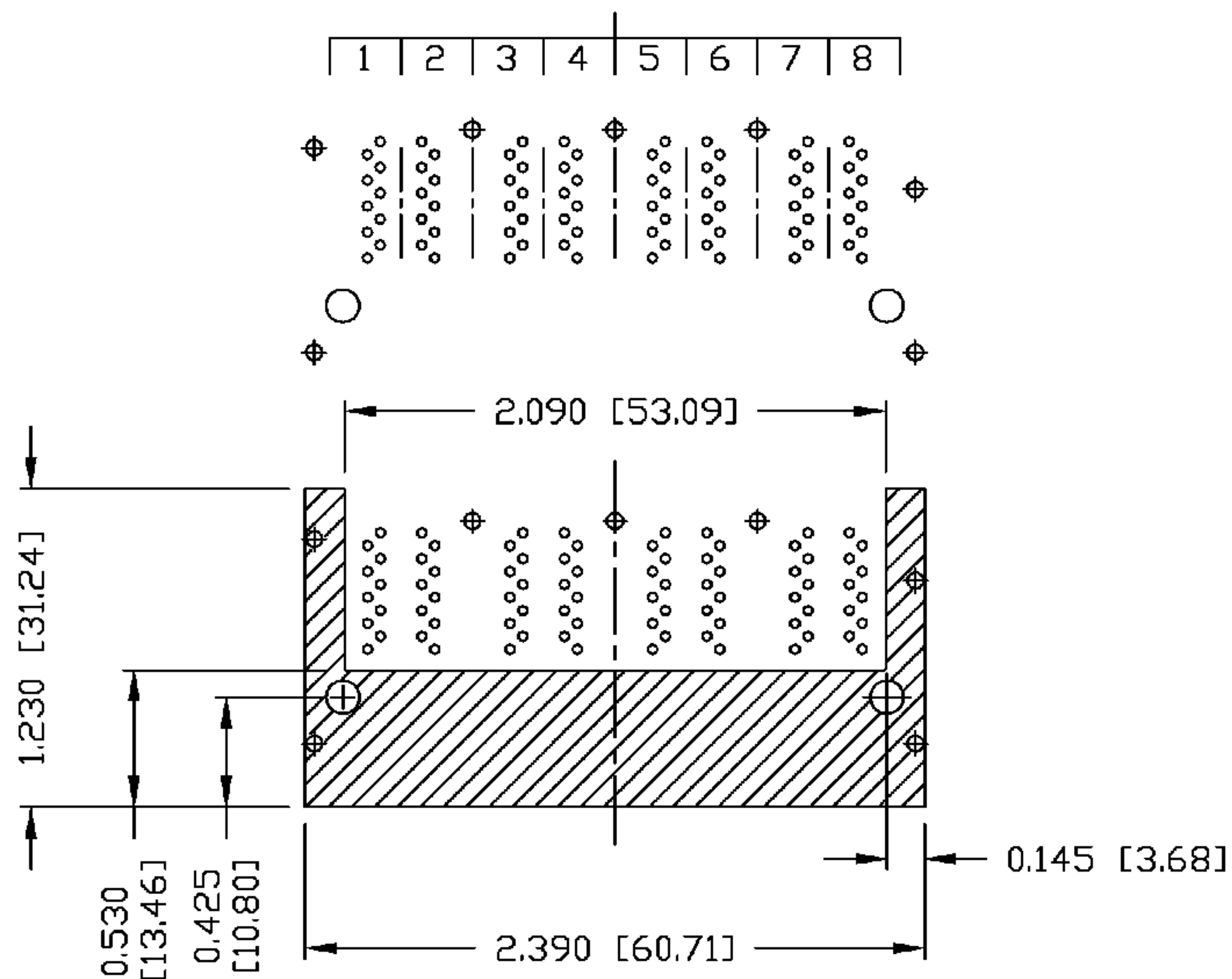

THE SHADED AREA ON THE CUSTOMER BOARD ARE RECOMMENDED TO BE CLEAR OFF ANY VIA HOLE OR COMPONENT PAD.

| | | | | | | |
|-----------------------------|------------------|--|--|-------------------------------------|--|-----------|
| ORIGINATED BY BILL/KEUNG | DATE 03-21-06 | TITLE 2X4 gigabit MagJack® (8 Cores) | PART NO. / DRAWING NO. 08332X4R54-F | STANDARD DIM. TOL. IN INCH .X | [] METRIC DIM. AS REFERENCE UNIT : INCH [mm] | REV. : B |
| DRAWN BY LING | DATE 03-21-06 | 0833-2X4R-54-F | FILE NAME 08332X4R54-F.B.DWG | .XX | SCALE : N/A | SIZE : A4 |
| | | | | .XXX ±0.004 | | PAGE : 4 |



THE INFORMATION CONTAINED HEREIN IS CONSIDERED "PROPRIETARY" TO BEL FUSE INC. AND SHALL NOT BE COPIED, REPRODUCED OR DISCLOSED WITHOUT THE WRITTEN APPROVAL OF BEL FUSE INC.

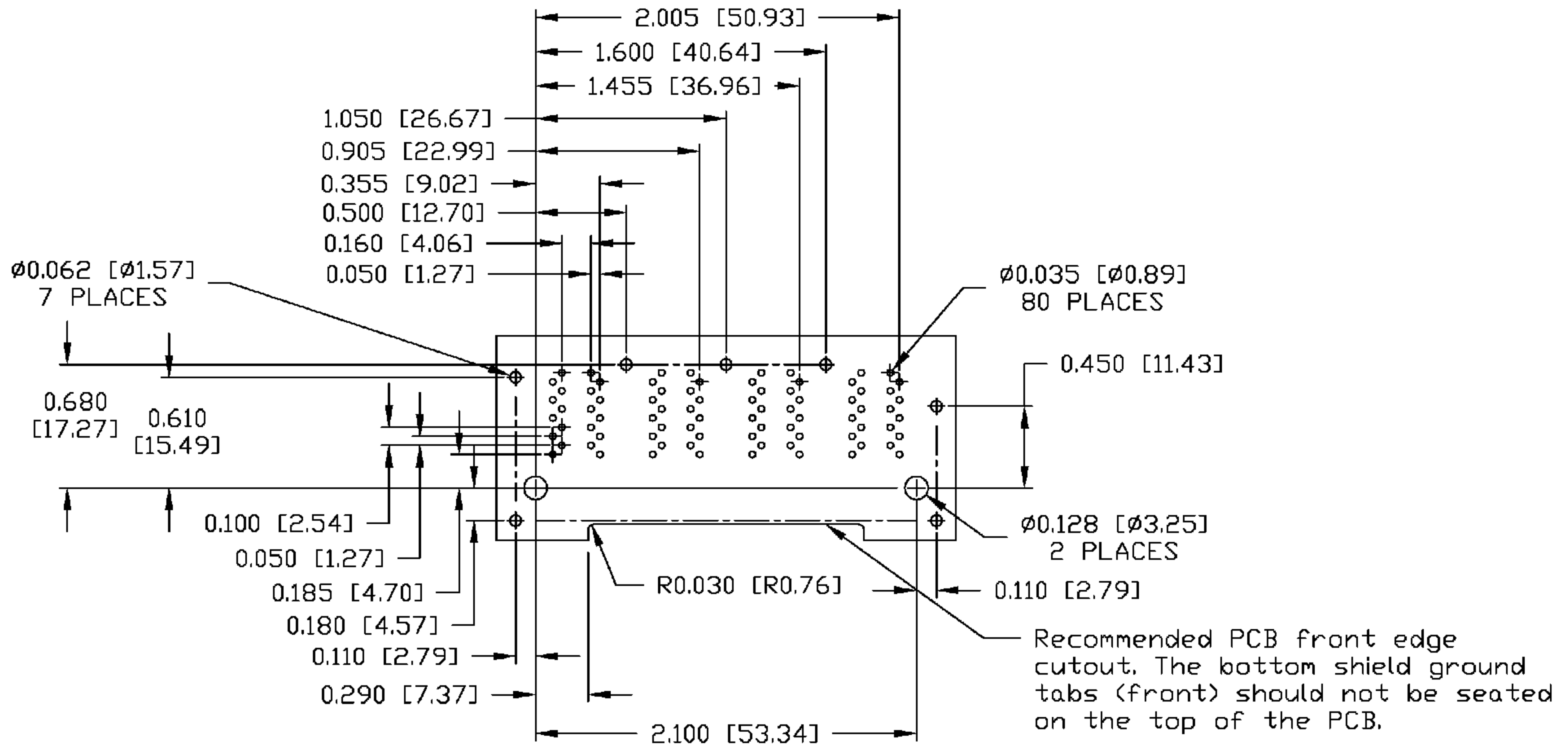

SUGGESTED FOOTPRINT
(COMPONENT SIDE VIEW)

| | | | | | | |
|---------------|----------|-----------------------------------|------------------------|---------------|------------------------------|-----------|
| ORIGINATED BY | DATE | TITLE | PART NO. / DRAWING NO. | STANDARD DIM. | [] METRIC DIM. AS REFERENCE | |
| BILL/KEUNG | 03-21-06 | 2X4 gigabit MagJack® (8 Cores) | 08332X4R54-F | TOL. IN INCH | UNIT : INCH [mm] | REV. : B |
| DRAWN BY | DATE | | FILE NAME | .X | SCALE : N/A | SIZE : A4 |
| LING | 03-21-06 | 0833-2X4R-54-F | 08332X4R54-FB.DWG | .XX | | PAGE : 5 |
| | | | | .XXX ±0.004 | | |



THE INFORMATION CONTAINED HEREIN IS CONSIDERED "PROPRIETARY" TO BEL FUSE INC. AND SHALL NOT BE COPIED, REPRODUCED OR DISCLOSED WITHOUT THE WRITTEN APPROVAL OF BEL FUSE INC.



SUGGESTED PANEL OPENING

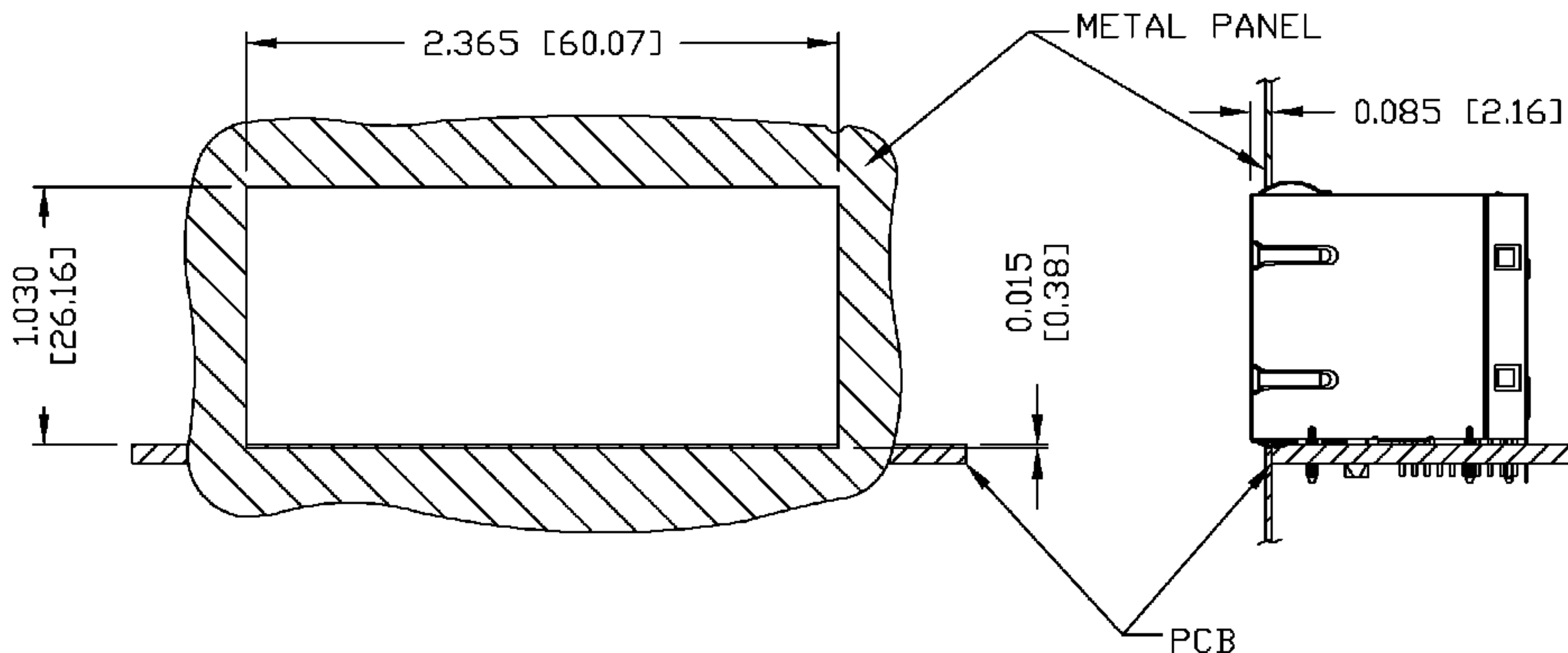

NOTES:

THE DISTANCE OF PANEL INSIDE SURFACE RELATIVE TO FRONT SURFACE OF PART IS ONLY A SUGGESTION. IN CASE THIS DISTANCE IS DIFFERENT, THE REQUIRED PANEL OPENING DIMENSIONS CHANGE ACCORDINGLY.

PACKING INFORMATION

PACKING TRAY : 0200-0148-46 (TOP)

0200-0148-47 (BOTTOM)

PACKING QUANTITY : 20 PCS FINISHED GOODS PER TRAY.

7 TRAYS (140 PCS FINISHED GOODS) PER CARTON BOX.

NOTE : CARDBOARDS ARE PLACED BETWEEN LAYERS OF PACKING TRAY INSIDE CARTON BOX.
(INCLUDE THE UPPERMOST AND LOWERMOST TRAY)

| | | | | | | | | |
|-----------------------------|------------------|--|--|---------------|------------------|------------------------------|-----------|---|
| ORIGINATED BY BILL/KEUNG | DATE 03-21-06 | TITLE 2X4 gigabit MagJack® (8 Cores) 0833-2X4R-54-F | PART NO. / DRAWING NO. 08332X4R54-F | STANDARD DIM. | | [] METRIC DIM. AS REFERENCE | | COMPONENTS FOR A CONNECTED PLANET |
| | | | | TOL. IN INCH | UNIT : INCH [mm] | REV. : B | | |
| DRAWN BY LING | DATE 03-21-06 | | FILE NAME 08332X4R54-FB.DWG | .X | | SCALE : N/A | SIZE : A4 | |
| | | | | .XX | | | PAGE : 6 | |
| | | | | .XXX | ±0.004 | | | |

X-ON Electronics

Largest Supplier of Electrical and Electronic Components

Click to view similar products for [Modular Connectors / Ethernet Connectors](#) category:

Click to view products by [Bel Fuse](#) manufacturer:

Other Similar products are found below :

[8949-H88/06BLKA/SN](#) [74441-0010/BKN](#) [MP1010RX-1000](#) [MP44RX-1000](#) [PHJ-4P4C-1-V-4](#) [PHP-6P6C-5](#) [GAX-3-66](#) [GAX-8-62](#) [GDCX-PA-66-50](#) [GDCX-PN-64](#) [GDCX-PN-66](#) [GDCX-PN-66-50](#) [GDLX-A-66](#) [GDLX-N-66](#) [GDLX-S-66](#) [GDLX-S-88K](#) [GDLX-SMT-S-88](#) [GDTX-S-88-50](#) [GDX-PA-1010](#) [GLX-N-1010M-BLK](#) [GLX-S-88M-BLK](#) [GMX-N-1010](#) [GMX-S-1010](#) [GMX-S-66](#) [GMX-SMT4-N-88](#) [GPX-2-64](#) [GSGX-N-2-88](#) [GSGX-N-4-88](#) [GSX-NS2-88-3.05](#) [GSX-NS2-88-3.05-50](#) [GSX-NS-88-3.05-50](#) [PT-108A-8C-UL](#) [PT-J951-8C](#) [PTS-J531-8CS-50UL](#) [1-1775629-2](#) [A-2014-0-4](#) [GWLX-S-88-GR](#) [GWLX-S9-88-YG](#) [DC-1021-8-WH-6](#) [1300530003](#) [1324640-4](#) [RJ11FTVC2G](#) [RJ11FTVC2N](#) [RJFTVX2SA1G](#) [132764-001](#) [1413235](#) [MP88X-1000](#) [MPS88RX-5000](#) [E5288-S000K3-L](#) [E5908-15A242-L](#)