

# 0RCY-F0S10x

## Isolated DC-DC Convert

The 0RCY-F0S10x is an isolated DC/DC converter that operate from a nominal 50 V/54 V source. This converter is intended to provide isolation and step down to generate a regulated intermediate bus for the purpose of powering non-isolated Point-of-Load (POL) converters.

This unit will provide up to 500 W of output power from a nominal 50 V/54 V input. The output of the converter has the droop function which allow the modules operating in parallel with high output current sharing precision.

This converter is provided in an 1/8 brick package.

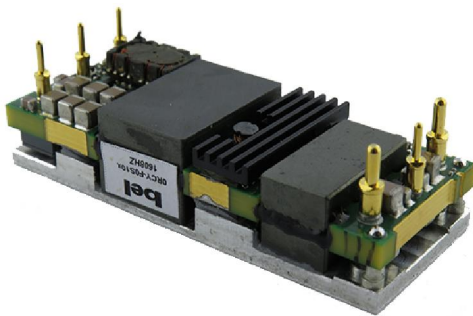

### Key Features & Benefits

- 45-56 VDC Input / 10.2 VDC @ 49 A Output
- Output /1/8th Brick Converter
- Isolated
- Fixed Frequency (300 kHz)
- High Efficiency
- High Power Density
- Input Under Voltage Lockout
- OCP/SCP
- Output Over-voltage Protection
- Over Temperature Protection
- Remote On/Off
- Parallel Operation
- Low Cost
- Approved to UL/CSA 60950-1, 2nd +A2 version(pending)
- Class 2, Category 2, Isolated DC/DC Converter (refer to IPC-9592B)

### Applications

- Networking
- Computers and peripherals
- Telecommunications

## 1. MODEL SELECTION

MODEL NUMBER	OUTPUT VOLTAGE	INPUT VOLTAGE	MAX. OUTPUT CURRENT	MAX. OUTPUT POWER	TYPICAL EFFICIENCY
ORCY-F0S10L	10.2 VDC	45 VDC – 56 VDC	49 A	500 W	97%
ORCY-F0S10B	10.2 VDC	45 VDC – 56 VDC	49 A	500 W	97%
ORCY-F0S10D	10.2 VDC	45 VDC – 56 VDC	49 A	500 W	97%

**NOTE:** Add "G" suffix at the end of the model number to indicate Tray Packaging.

### PART NUMBER EXPLANATION

0	R	CY	-	F0	S	10	x	y
Mounting Type	RoHS Status	Series Name		Output Power	Input Range	Output Voltage	Active Logic	Package Type
Through hole mount	RoHS	1/8th Brick		500 W	45 – 56V	10.2 V	L – active low, with HSK B – active low, with HSK plate D – active low, with HSK with Fins	G – Tray package

## 2. ABSOLUTE MAXIMUM RATINGS

PARAMETER	DESCRIPTION	MIN	TYP	MAX	UNITS
Continuous non-operating Input Voltage		-0.3	-	60	V
Remote On/Off		-0.3	-	16	V
Ambient temperature, Long-Term Operating	The components on the Unit meet IPC-9592 derating guidelines	-5	-	85	°C
Ambient temperature, Short-Term Operating (96 hours/year)	The component temperatures might exceed IPC-9592 derating guidelines but not exceed component temperature ratings	-20	-	90	°C
Altitude		-	-	4000	m
Storage Temperature		-40	-	100	°C

**NOTE:** Ratings used beyond the maximum ratings may cause a reliability degradation of the converter or may permanently damage the device.

### 3. INPUT SPECIFICATIONS

All specifications are typical at 25°C unless otherwise stated.

PARAMETER	DESCRIPTION	MIN	TYP	MAX	UNIT
Operating Input Voltage		45	50/54	56	V
Input Current (full load)		-	-	12	A
Input Current (no load)		-	100	120	mA
Remote Off Input Current		-	20	30	mA
Input Reflected Ripple Current (rms)	Vin=45-56V, Io=100% load, With simulated source impedance of 10uH, 5Hz to 20MHz. Use a 470uF/80V electrolytic capacitor.	-	5	10	mA
Input Reflected Ripple Current (pk-pk)		-	18	30	mA
I <sub>pt</sub> Inrush Current Transient	Vin=50V, with a 100uF/100V input electrolytic capacitor	-	-	1	A <sup>2</sup> s
Turn-on Voltage Threshold		42.5	44	45.0	V
Turn-off Voltage Threshold		39.0	41	42.5	V
Over-voltage Shutdown Threshold	Output shuts down after 20ms delay.	58	-	61	V
	Output shuts down immediately.	61	-	64	V

**CAUTION: This converter is not internally fused. An input line fuse must be used in application.** Recommend a fast-acting fuse with maximum rating of 15 A on system board. Refer to the fuse manufacture's datasheet for further information.

#### 4. OUTPUT SPECIFICATIONS

All specifications are typical at nominal input, full load at 25°C unless otherwise stated.

PARAMETER	DESCRIPTION	MIN	TYP	MAX	UNIT
Output Voltage Set Point	Vin=45-56V, Pout=250W	10.45	10.5	10.55	V
	Vin=45-56V	10.15	-	10.88	V
Load Regulation( Output drop voltage )	Vin=50V, Io=0~100% load.	-	0.60	0.73	V
Line Regulation	Vin=45~56V,Io=100% load	-	25	40	mV
Regulation Over Temperature		-	± 30	± 60	mV
Ripple and Noise (pk-pk)	Vin=50V, Io=100%load, 0-20MHz BW, with 3 * 22 µF ceramic capacitor at output.	-	45	90	mV
Ripple and Noise (rms)		-	12	25	mV
Output Ripple and Noise(Pk-Pk) under worst case	Over all operating input voltage, load and ambient temperature condition	-	-	150	mV
Output Current Range		0	-	49	A
Output DC Current Limit		55	61	68	A
Current Share Accuracy	Vin=50V, Io=20% -100% full load, two unit paralleling operation	-	-	± 5	%
Rise time		-	-	15	ms
Turn on Time	Enable from Vin to 10% of Vout	20	-	30	ms
	Enable from ON/OFF to 10% of Vout	-	-	5	ms
Overshoot at Turn on	Overshoot at turn on	0	-	3	%
Output Capacitance	50% ceramic + 50% Oscon	0	-	3125	µF
<b>Transient Response</b>					
ΔV 50%~75% of Max Load		-	160	350	mV
Settling Time	di/dt=1A/us, Vin=50Vdc, with 8 * 22 µF ceramic capacitor and 1940uF AL. cap at output.	-	100	200	us
ΔV 75%~50% of Max Load		-	160	350	mV
Settling Time		-	100	200	us

5. OUTPUT PLOT VS INPUT

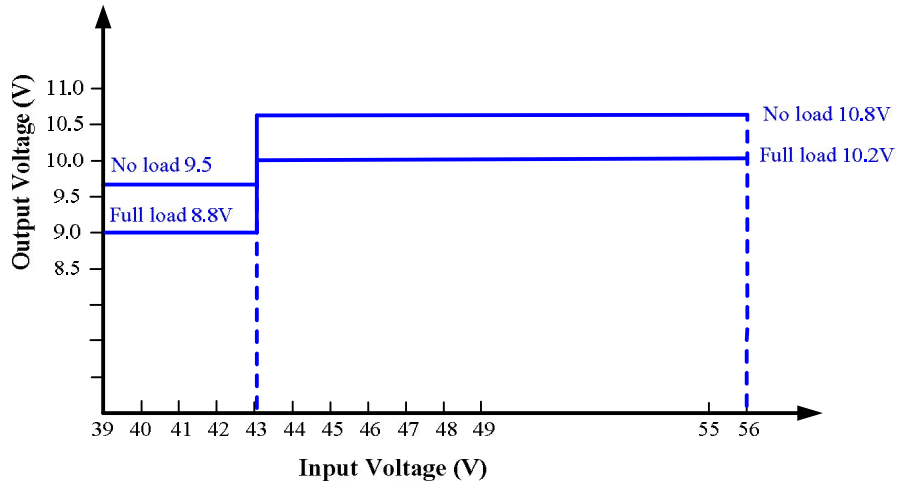

Note:

PARAMETER	MIN	TYP	MAX	UNITS
Turn-on Voltage Threshold	42.5	44	45	V
Turn-off Voltage Threshold	39	41	42.5	V

6. GENERAL SPECIFICATIONS

PARAMETER	DESCRIPTION	MIN	TYP	MAX	UNIT
Efficiency	Vin=50V, full load	95	97	-	%
Switching Frequency		280	300	320	kHz
Over Temperature Protection		-	130	-	°C
Output Over Voltage Protection		-	-	15	V
Weight	0RCY-F0S10L	-	41.7	-	g
	0RCY-F0S10B	-	52.4	-	g
	0RCY-F0S10D	-	76.2	-	g
MTBF	Calculated Per Telcordia SR-332, Issue 3 (Vin=50 V, Po=500W, Ta = 25C)	2.0	TBD	-	Mhrs
Dimensions Inches (L x W x H) Millimeters (L x W x H)	0RCY-F0S10L	2.30 x 0.90 x 0.48 58.42 x 22.86 x 12.20			Inches Millimeters
	0RCY-F0S10B	2.30 x 0.90 x 0.57 58.42 x 22.86 x 14.50			Inches Millimeters
	0RCY-F0S10D	2.30 x 0.90 x 1.18			Inches
		58.42 x 22.86 x 30.00			Millimeters
<b>Isolation Characteristics</b>					
Input to Output		-	-	500	V
input to case		-	-	500	V
output to case		-	-	500	V
Isolation Resistance		10M	-	-	Ohm
Isolation Capacitance		-	1000	-	pF



Asia-Pacific  
+86 755 298 85888

Europe, Middle East  
+353 61 225 977

North America  
+1 408 785 5200

7. EFFICIENCY DATA

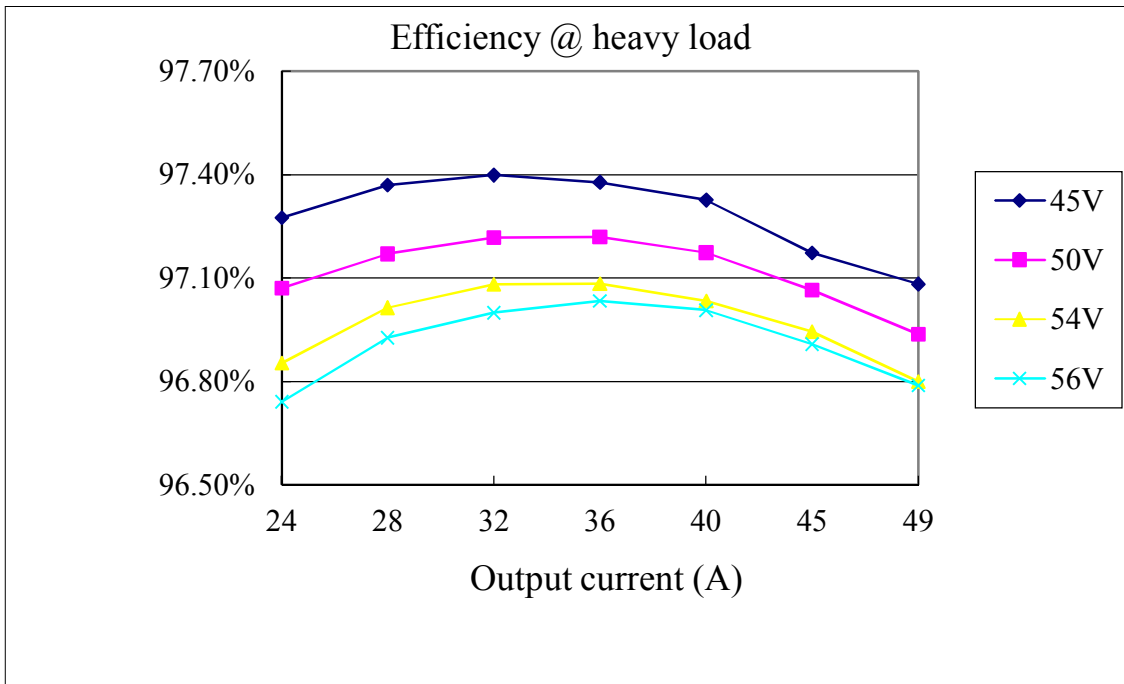
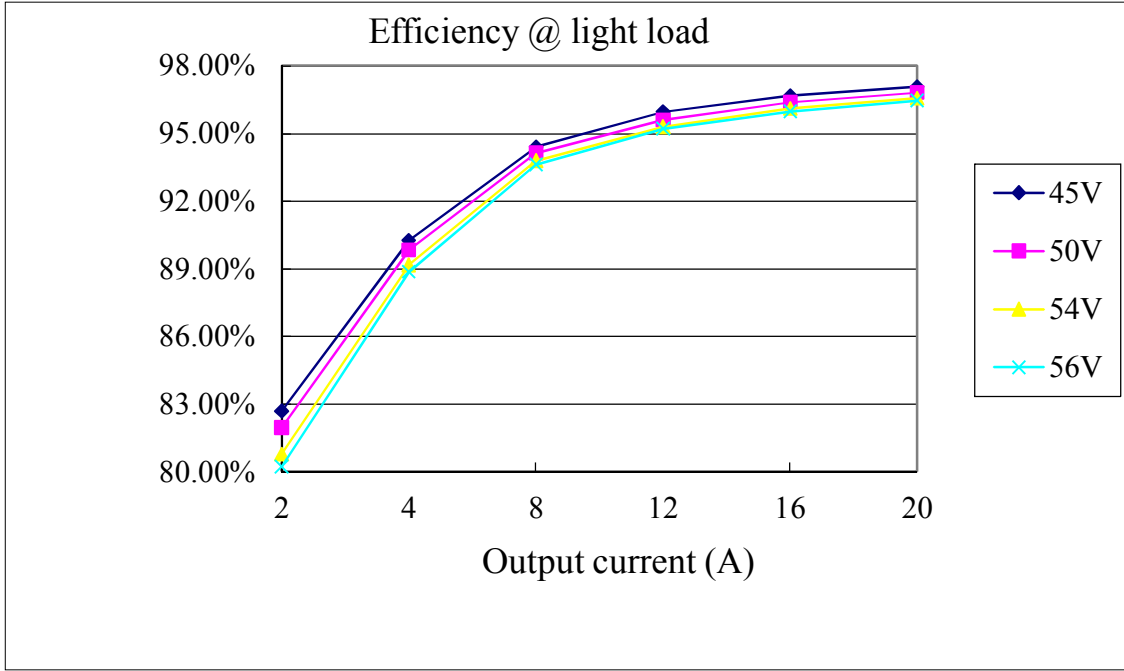

**8. REMOTE ON/OFF**

PARAMETER		DESCRIPTION	MIN	TYP	MAX	UNIT
Signal Low (Unit On)	Active Low	Remote On/Off pin is open, the module is off.	-0.3	-	0.8	V
Signal High (Unit Off)			2.4	-	16	V
Current (Out of pin)		Module is on, Venab= -0.3-0.8V	-	-	200	µA
		Module is off, Venab=2.4V	10	-	-	µA
Current (into pin)		Remote on/off pin is pulled up to 10V.	-	-	300	µA
		Remote on/off pin is pulled up to 15V.	-	-	500	µA
Open circuit voltage			-	-	15	V

Recommended remote on/off circuit for active low

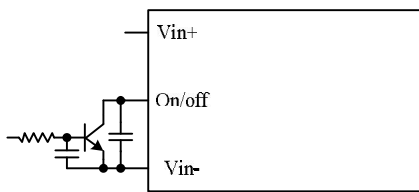

Control with open collector/drain circuit

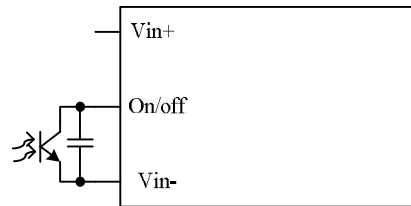

Control with photocoupler circuit

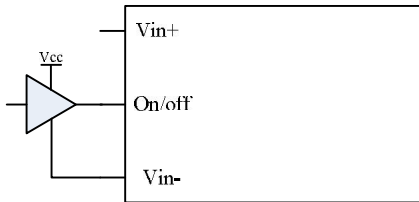

Control with logic circuit

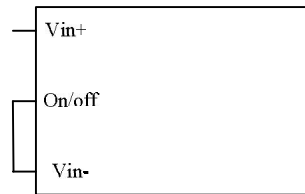

Permanently on

## 9. POWER GOOD

### Note:

1. The Power Good signal is a non-latching open-collector output that is Low during normal operation and is pulled High when any of the following conditions occur:

- Over-Temperature
- Over-Current
- Vout is outside of the DC Output Band while Vin is within the Vin Operating Range
- Vin is within the Vin Operating Range but the unit is not operating (to determine if 1 Unit used in a parallel configuration is not operating)
- Vin is outside of the Vin Operating Range

2. The Power Good signal is referenced to Vout(-).

PARAMETER	DESCRIPTION	MIN	TYP	MAX	UNIT
Output Voltage Low (trigger limits)		8.2	-	8.6	V
Output Voltage High (trigger limits)		12.6	-	13.1	V
Input Voltage Low (trigger limits) Rising	PG signal indicates good when Vin is within operating range and indicates bad ~20ms before unit is shut-down due to UV or OV	42.5	-	45	V
Input Voltage High (trigger limits) Rising		58	-	61	V
Hysteresis		-	1	-	V
High State Voltage		0	-	5.5	V
High State Leakage Current (into Pin)		0	-	10	μA
Low State Voltage		0	-	0.8	V
Low State Current (into Pin)		0	-	5	mA
Power Good Signal De-assert Response Time	Duration between the fault occurring and the Power-Good Signal de-asserting	0	-	3	ms
Power Good Signal Assert Response Time	Duration between unit powering up with no faults and the Power Good Signal asserting	0	-	3	ms
Power Good Signal Duration	Duration the Power-Good signal stays de-asserted if a transient fault occurs	200		600	ms
Over Temperature Warning	For OT Warning, the PG signal will toggle as an impulse wave.		10degC below OTP threshold		°C
OT Warning PG signal frequency		90	100	110	kHz
OT Warning PG signal duty cycle		47.5	50	52.5	%



**10. OVER CURRENT PROTECTION**

To provide protection in a fault output overload condition, the module is equipped with internal current-limiting circuitry and can endure current limiting for a few milli-seconds. If the overcurrent condition persists beyond a few milliseconds, the module will shut down into hiccup mode and restart once every 400ms. The module operates normally when the output current goes into specified range. The typical average output current is 5.6A during hiccup.

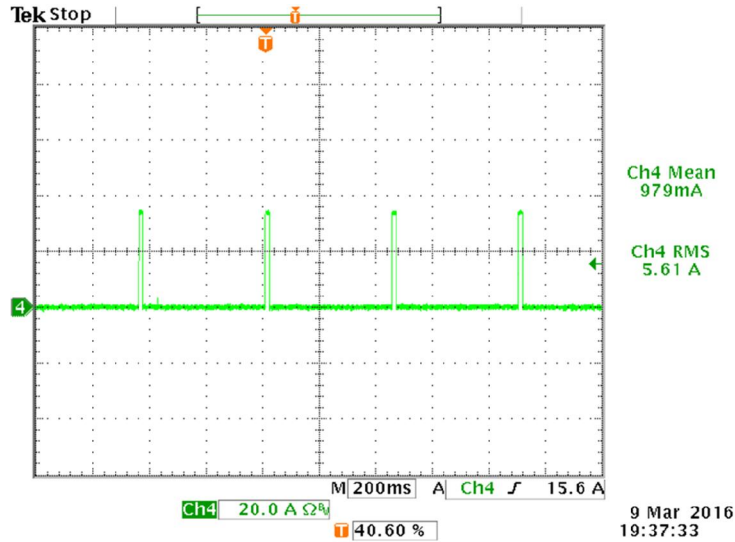

CH4: Output Current Waveform  
Test condition: Vin=54V

**11. INPUT REFLECTED RIPPLE CURRENT**

Testing setup

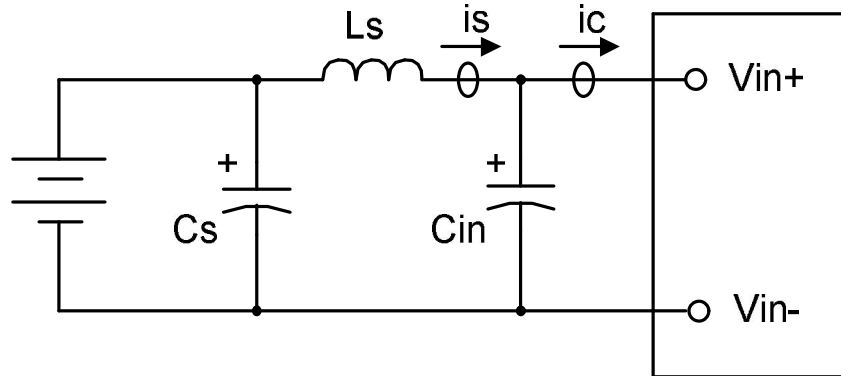

Notes and values in testing.

*is*: Input Reflected Ripple Current

*ic*: Input Terminal Ripple Current

*Ls*: Simulated Source Impedance (10μH)

*Cs*: NIL

*Cin*: Electrolytic capacitor, should be as closed as possible to the power module to swallow *ic* ripple current and help with stability.

Recommendation: 470uF, ESR<0.045Ω @100KHz,20 °C

Below measured waveforms are based on above simulated and recommended inductance and capacitance.

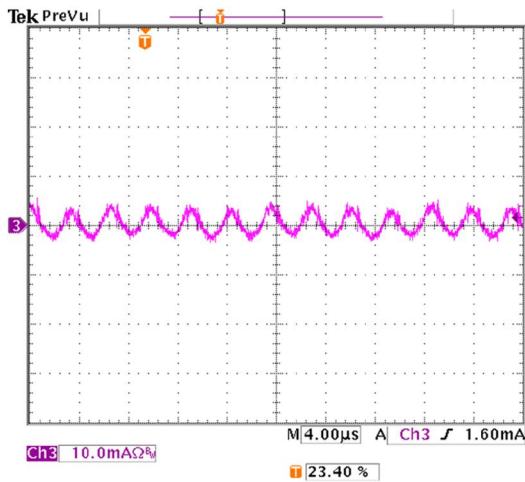

*is* (input reflected ripple current), AC component

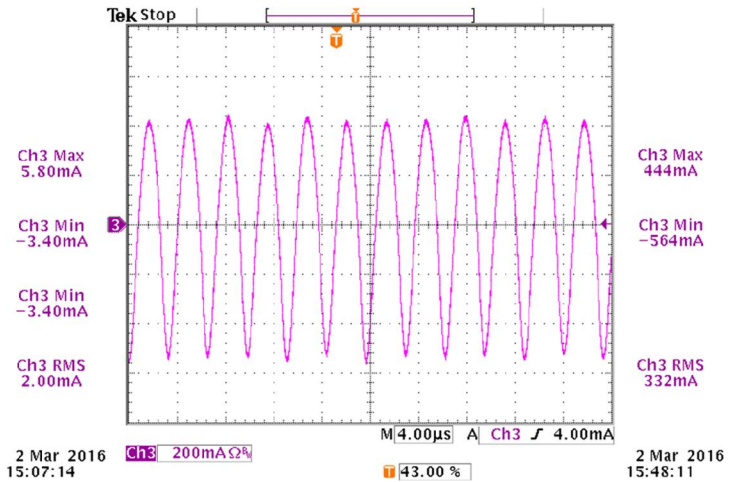

*ic* (input terminal ripple current), AC component

**Test condition:** 50Vdc input, 10.2Vdc/49A output and Ta=25 deg C, with 8 \* 22 μF ceramic capacitor and 1940uF AL. cap at output.

12. RIPPLE AND NOISE WAVEFORM

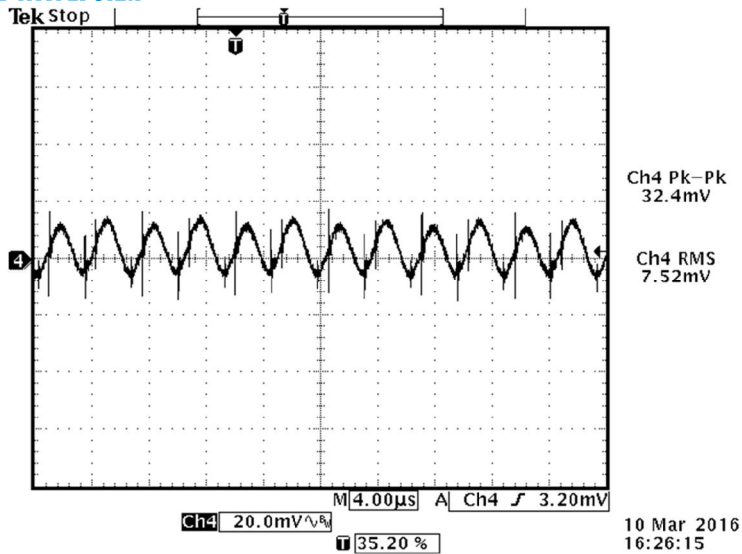

Ripple and noise, 54Vdc input, 500W output, Ta=25 deg C, with Cout = 500µF (50% ceramic, 50%)

13. TRANSIENT RESPONSE WAVEFORMS

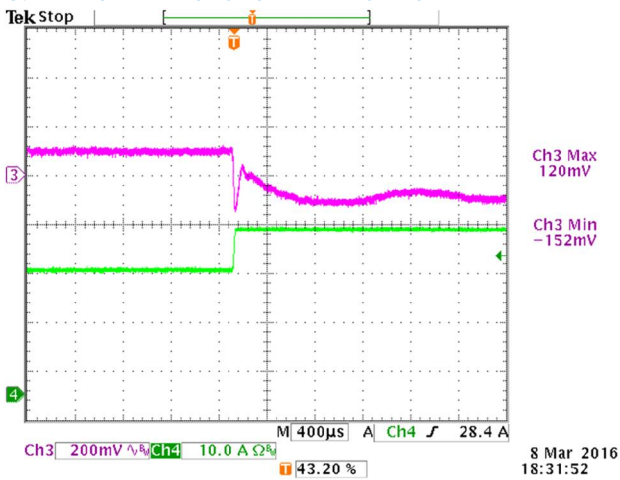

CH3: Vo  
CH4: Io

50%-75% Load Transients at Vin=50V@Ta=25 °C

Note: Transient Response: di/dt=1A/µS, with 8 \* 22 µF ceramic capacitor and 1940µF AL. cap at output.

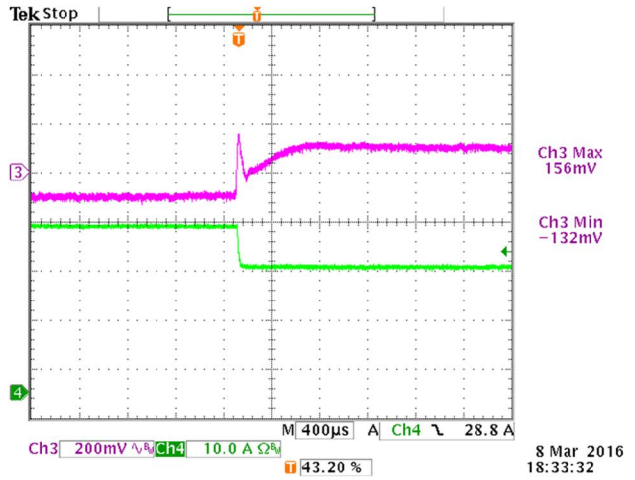

CH3: Vo  
CH4: Io

75%-50% Load Transients at Vin=50V@Ta=25 °C

Note: Transient Response: di/dt=1A/µS, with 8 \* 22 µF ceramic capacitor and 1940µF AL. cap at output.



Asia-Pacific  
+86 755 298 85888

Europe, Middle East  
+353 61 225 977

North America  
+1 408 785 5200

**14. INPUT UNDER-VOLTAGE LOCKOUT**

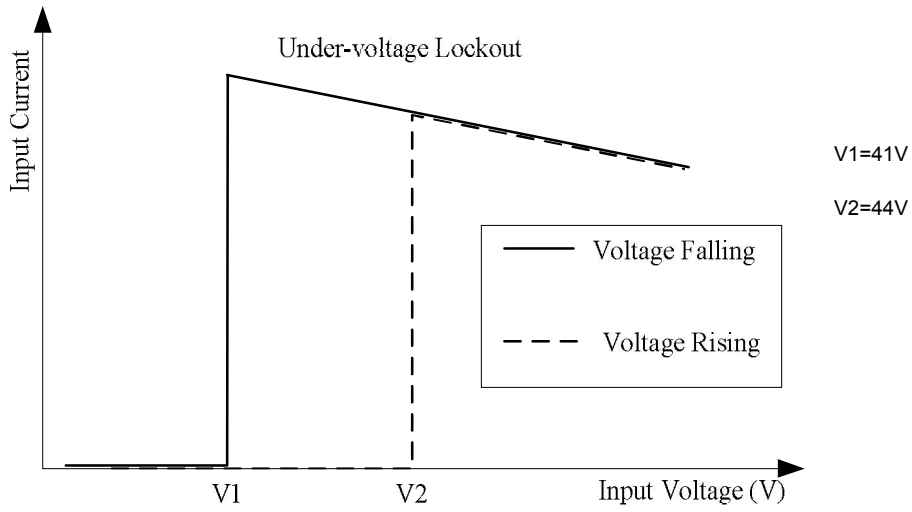

**15. STARTUP&SHUTDOWN**

Turn on Rise time

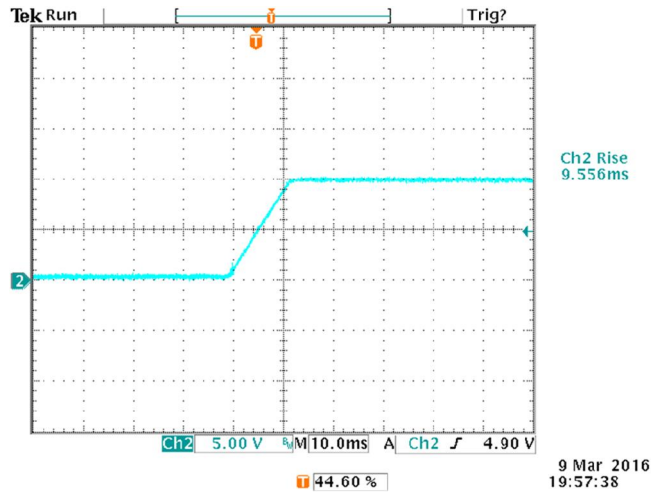

*Vin= 50V, Po=500W, with Cext=3125Uf*

**STARTUP & SHUTDOWN(CONTINUED)**

**Turn on delay time**

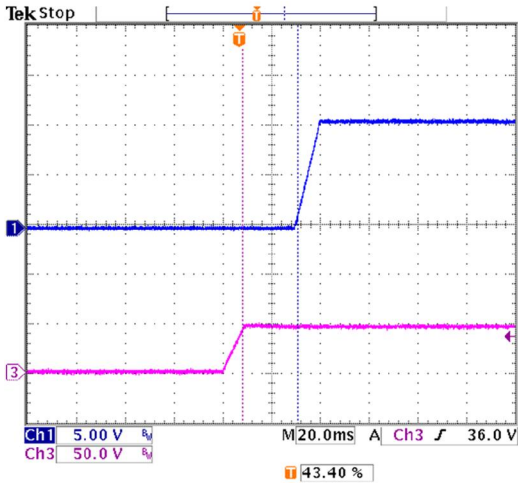

Startup from Vin  
Ch1: Vo  
Ch3: Vin  
Vin= 50V, Po=500W, with Cext=3125uF

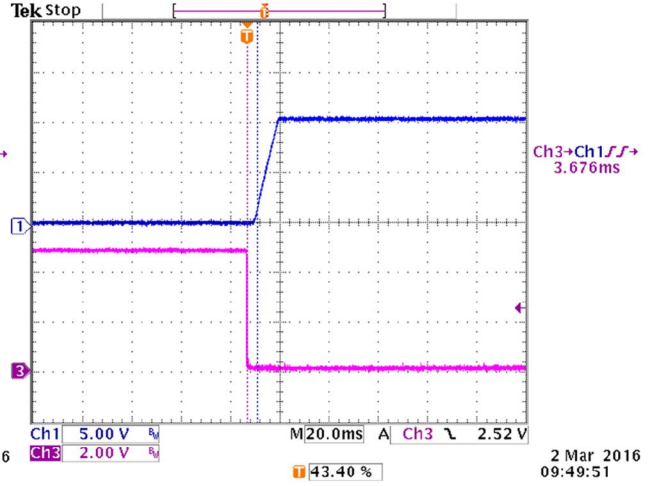

Startup from on/off Logic low  
Ch1: Vo  
Ch3: on/off  
Vin= 50V, Po=500W, with Cext=3125uF

**Shutdown**

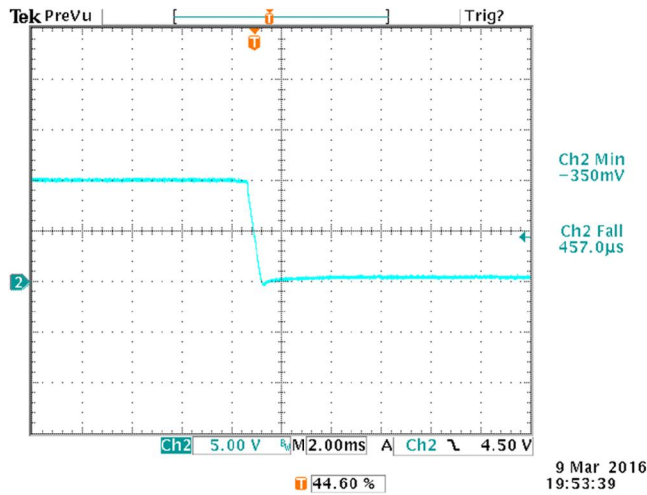

Vin=50V, Po=500W, with Cext=3125uF

**16. THERMAL CONSIDERATIONS**

New high power architectures require an accurate thermal design. Design engineers have to optimize the module working conditions and ensure reliable operation. Convection cooling is the common mode to cool down the module. Heat transfer is dependent on a test setup and it is important to characterize the module in an environment similar to existent electronic applications. Reported thermal data reflects real operating conditions because the values are physically measured in a wind tunnel.



Asia-Pacific  
+86 755 298 85888

Europe, Middle East  
+353 61 225 977

North America  
+1 408 785 5200

**17. THERMAL TEST SETUP**

A module in electronic cards is typically located in a busy area without relevant space around it. To simulate a real condition and avoid turbulence we add a cover with defined dimensions. The distance has to be 6.35mm (0.25"inch) from the top of the module and 6.35mm (0.25"inch) on the left and right side of the module. The values reflect most of the real applications and it is a common procedure in the power module market. Ambient temperature and airflow are measured in front of the module at the distance of 76.2mm (3"inch).

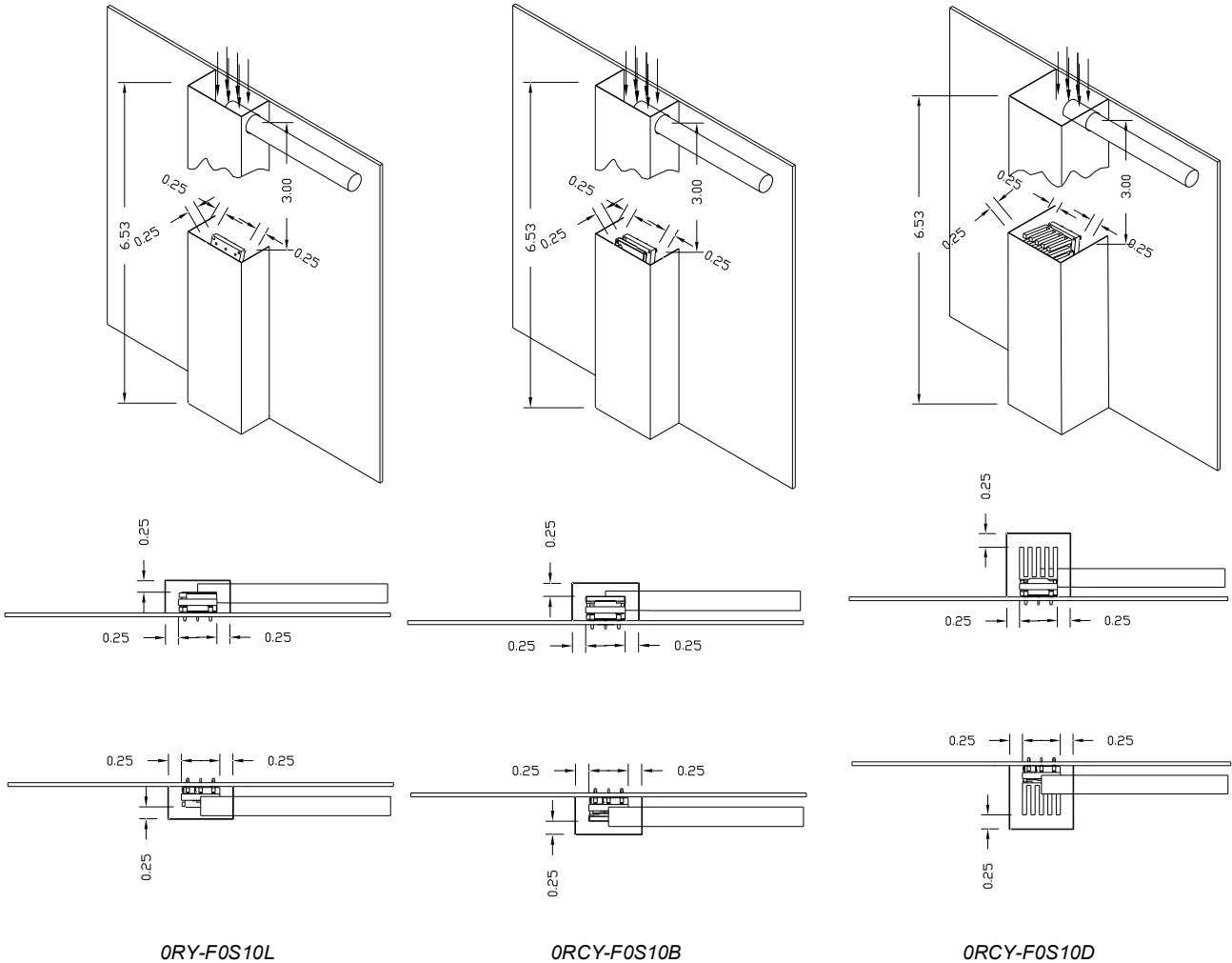

*Tests setup drawing all measures are in inch[mm]*

**18. THERMAL DERATING CURVE**

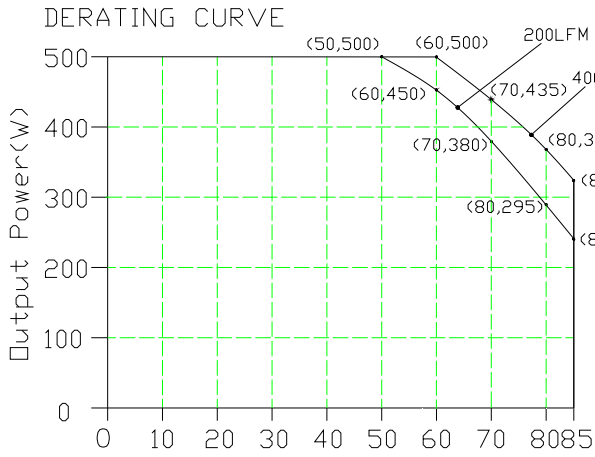

AMBIENT TEMPERATURE,  $T_a$ (°C)  
Output Power vs. Local Ambient Temperature and Air Velocity  
**ORCY-F0S10L**

*Note: Output power vs. ambient temperature and air velocity @  $V_{in}=56V$  (Longitudinal Orientation, airflow from Vout to Vin)*

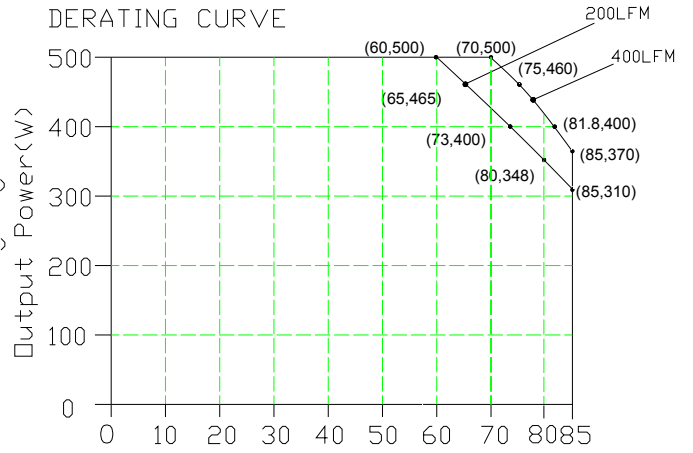

AMBIENT TEMPERATURE,  $T_a$ (°C)  
Output Power vs. Local Ambient Temperature and Air Velocity

**ORCY-F0S10B**

*Note: Output power vs. ambient temperature and air velocity @  $V_{in}=56V$  (Longitudinal Orientation, airflow from Vout to Vin)*

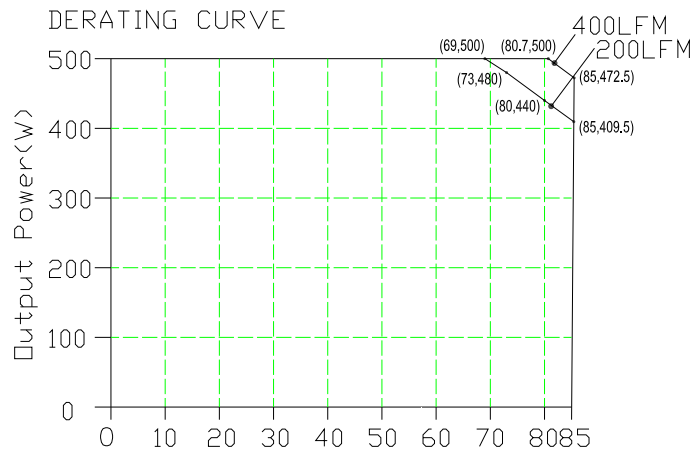

AMBIENT TEMPERATURE,  $T_a$ (°C)  
Output Power vs. Local Ambient Temperature and Air Velocity

**ORCY-F0S10D**

*Note: Output power vs. ambient temperature and air velocity @  $V_{in}=56V$  (Longitudinal Orientation, airflow from Vout to Vin)*



Asia-Pacific  
+86 755 298 85888

Europe, Middle East  
+353 61 225 977

North America  
+1 408 785 5200

**19. MECHANICAL DIMENSIONS**

**ORCY-FOS10L**

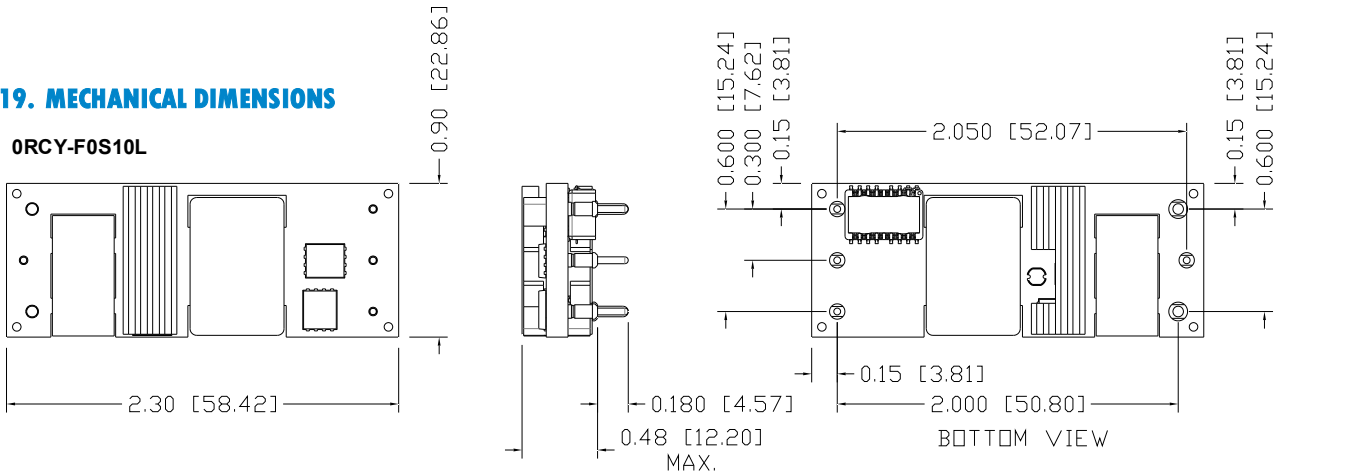

UNIT: INCH [mm]

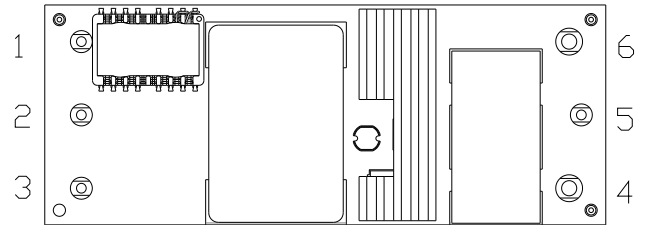
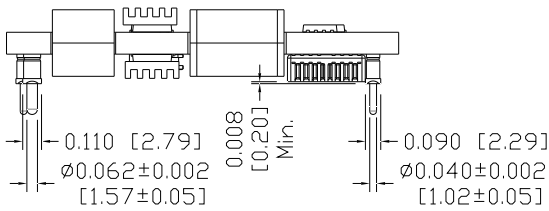

**BOTTOM VIEW**

**PIN CONNECTIONS**

PIN	FUNCTION	PIN SIZE
1	Vin (+)	0.04"
2	ON/OFF	0.04"
3	Vin (-)	0.04"
4	Vout(-)	0.062"
5	PG	0.04"
6	Vout(+)	0.062"

**RECOMMENDED PAD LAYOUT**

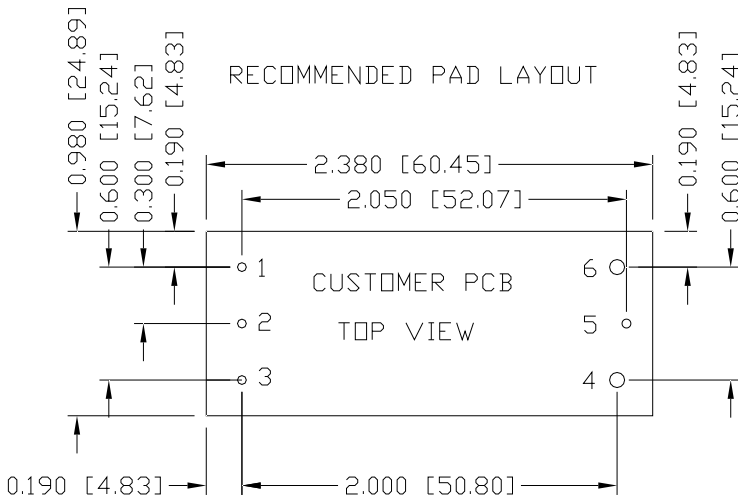

1,2,3,5  $\varnothing 0.050$  HOLE SIZE,  $\varnothing 0.11$  min PAD SIZE  
 4,6  $\varnothing 0.074$  HOLE SIZE,  $\varnothing 0.13$  min PAD SIZE

**Note:** This module is recommended and compatible with Pb-Free Wave Soldering and must be soldered using a peak solder temperature of no more than 260 °C for less than 5 seconds.

**NOTES:**

- 1) All Pins: Material - Copper Alloy; Finish - Tin plated
- 2) Undimensioned components are shown for visual reference only.
- 3) All dimensions in inches; Tolerances: x.xx +/-0.02 in [0.51 mm]. x.xxx +/-0.010 in [0.25 mm].



## 20. MECHANICAL DIMENSIONS

### ORCY-FOS10B

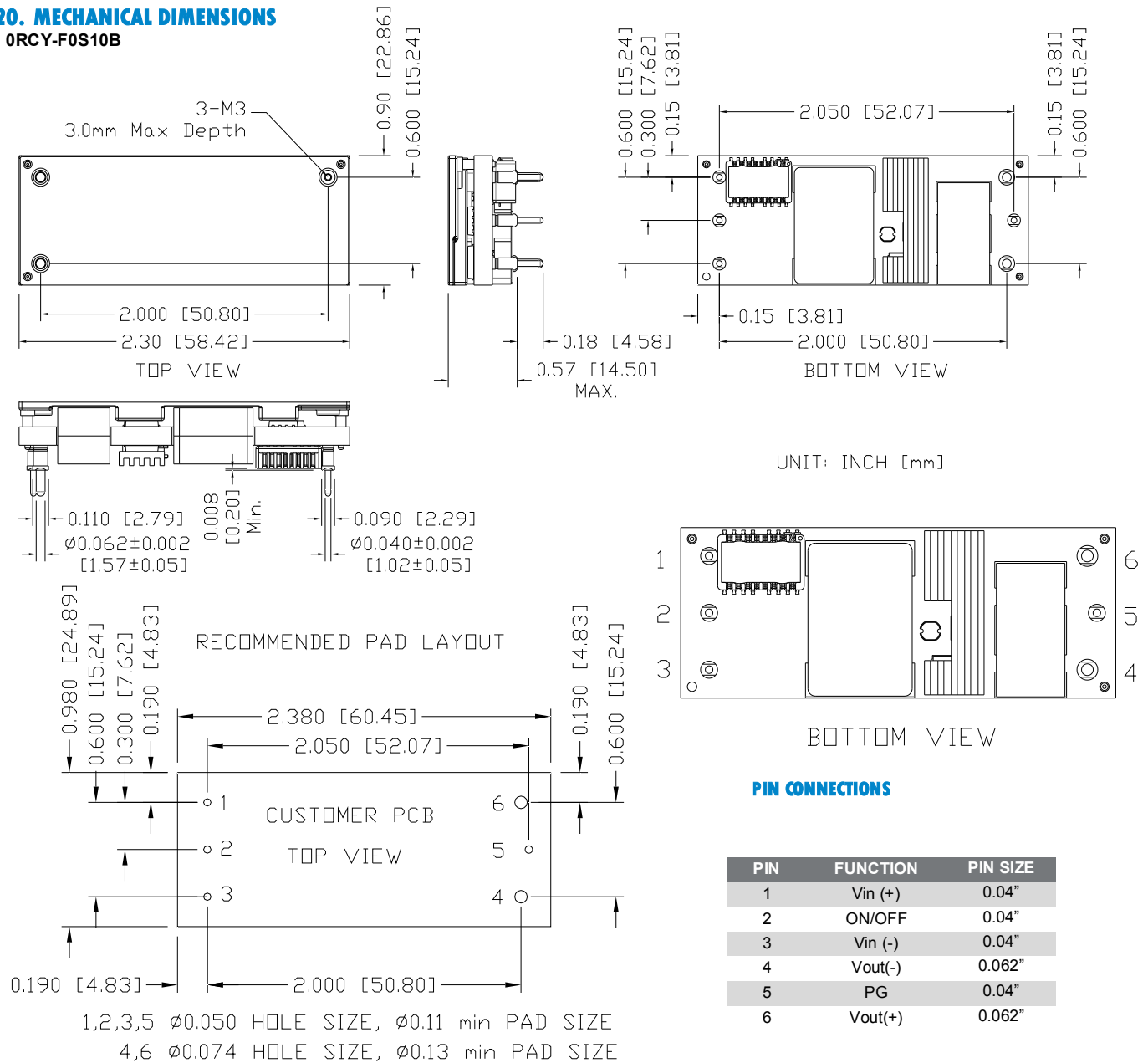

**Note:** This module is recommended and compatible with Pb-Free Wave Soldering and must be soldered using a peak solder temperature of no more than 260 °C for less than 5 seconds.

**NOTES:**

- 1) All Pins: Material - Copper Alloy; Finish – Tin plated
- 2) Undimensioned components are shown for visual reference only.

All dimensions in inches; Tolerances: x.xx +/-0.02 in [0.51 mm]. x.xxx +/-0.010 in [0.25 mm].



Asia-Pacific  
+86 755 298 85888

Europe, Middle East  
+353 61 225 977

North America  
+1 408 785 5200

**21. MECHANICAL DIMENSIONS**

**ORCY-FOS10D**

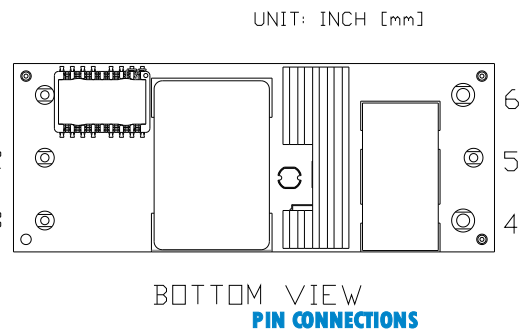
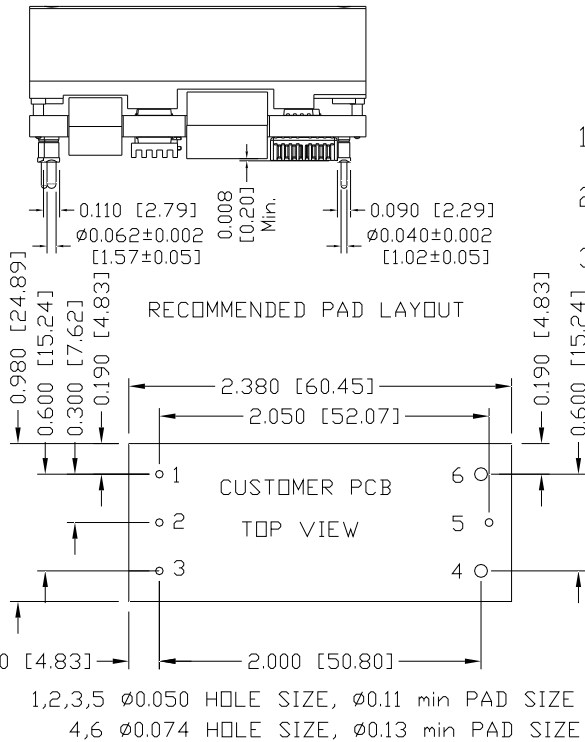
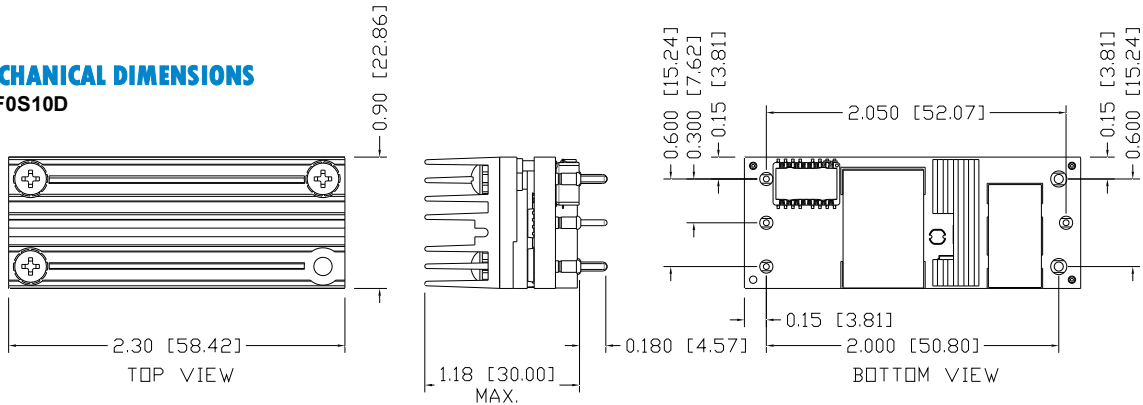

PIN	FUNCTION	PIN SIZE
1	Vin(+)	0.040"
2	ON/OFF	0.040"
3	Vin(-)	0.040"
4	Vout(-)	0.062"
5	PG	0.040"
6	Vout(+)	0.062"

**Note:** This module is recommended and compatible with Pb-Free Wave Soldering and must be soldered using a peak solder temperature of no more than 260 °C for less than 5 seconds.

**NOTES:**

- 1) All Pins: Material - Copper Alloy; Finish - Tin plated
- 2) Undimensioned components are shown for visual reference only.
- 3) All dimensions in inches; Tolerances: x.xx +/-0.02 in [0.51 mm]. x.xxx +/-0.010 in [0.25 mm].

**For more information on these products consult: [tech.support@psbel.com](mailto:tech.support@psbel.com)**

**NUCLEAR AND MEDICAL APPLICATIONS** - Products are not designed or intended for use as critical components in life support systems, equipment used in hazardous environments, or nuclear control systems.  
**TECHNICAL REVISIONS** - The appearance of products, including safety agency certifications pictured on labels, may change depending on the date manufactured. Specifications are subject to change without notice.



## X-ON Electronics

Largest Supplier of Electrical and Electronic Components

*Click to view similar products for [Isolated DC/DC Converters](#) category:*

*Click to view products by [Bel Fuse](#) manufacturer:*

Other Similar products are found below :

[ESM6D044440C05AAQ](#) [FMD15.24G](#) [PSL486-7LR](#) [Q48T30020-NBB0](#) [JAHW100Y1](#) [SPB05C-12](#) [SQ24S15033-PS0S](#) [18952](#) [19-130041](#)  
[CE-1003](#) [CE-1004](#) [GQ2541-7R](#) [RDS180245](#) [MAU228](#) [J80-0041NL](#) [DFC15U48D15](#) [XGS-0512](#) [XGS-1205](#) [XGS-1212](#) [XGS-2412](#) [XGS-2415](#) [XKS-1215](#) [06322](#) [NCT1000N040R050B](#) [SPB05B-15](#) [SPB05C-15](#) [L-DA20](#) [DCG40-5G](#) [QME48T40033-PGB0](#) [XKS-2415](#) [XKS-2412](#)  
[XKS-1212](#) [XKS-1205](#) [XKS-0515](#) [XKS-0505](#) [XGS-2405](#) [XGS-1215](#) [XGS-0515](#) [PS9Z-6RM4](#) [73-551-5038I](#) [AK1601-9RT](#) [VI-N61-CM](#) [VI-R5022-EXWW](#) [PSC128-7iR](#) [RPS8-350ATX-XE](#) [DAS1004812](#) [PQA30-D24-S24-DH](#) [VI-M5F-CQ](#) [VI-LN2-EW](#) [VI-PJW01-CZY](#)