

50 Ohm SMB PC Mount Straight Jack Receptacle

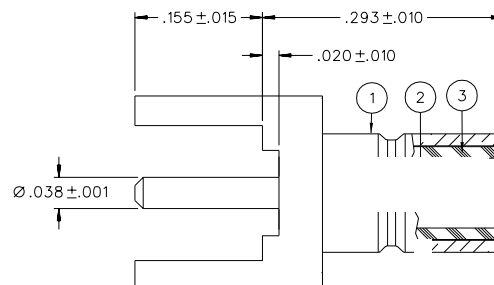

Mounting Hole Layout

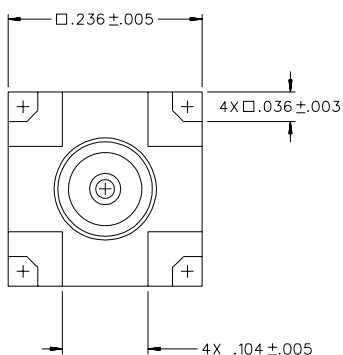
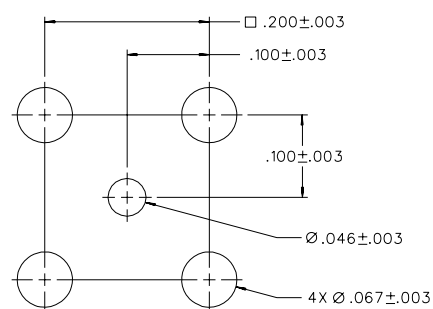

Mating Engagement for SMB Series per MIL-C-39012

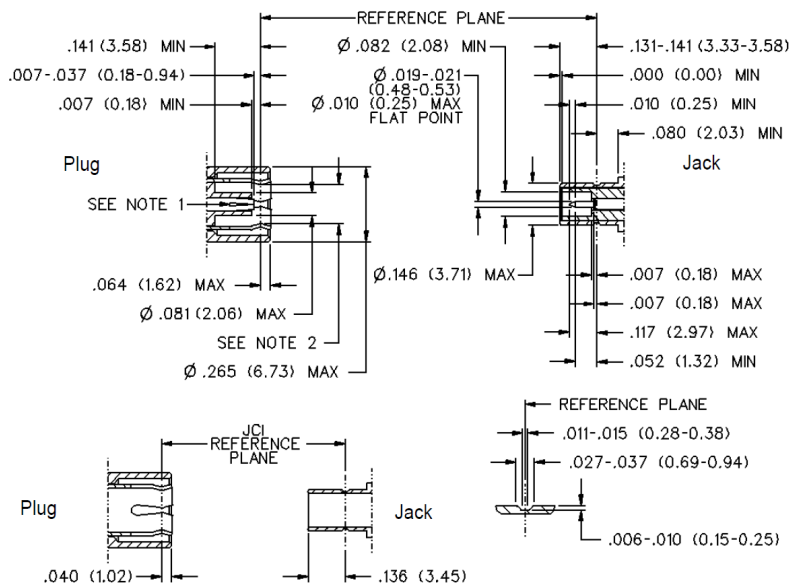

- NOTES
1. ID of contact to meet VSWR mating characteristics and connector durability when mated with a dia .019 / 0.53 male contact.
 2. Must meet the force to engage and disengage when mated with mating part.

50 Ohm SMB PC Mount Straight Jack Receptacle



Technical Specifications

Electrical Ratings

Impedance	50 ohm		
Frequency Range	Connectors	0 - 4 GHz	
	Dummy Loads	0 - 1 GHz	
VSWR (f = GHz)		Straight Cabled	Right Angle Cabled
	RG-178 Cable	1.30 + .04f	1.45 + .06f
	RG-316, RG-58, .086 Semi Rigid Cable	1.25 + .04f	1.35 + 0.4f
	Adapters	1.20 + .04f	
	Uncabled Receptacles, Dummy Loads	N/A	
Working Voltage (VRMS maximum)†	Connectors for Cable Type	Sea Level	70,000 Feet
	RG-178	250	60
	RG-316, RG-58, .086 Semi Rigid, Uncabled Receptacles, Adapters	335	85
	Dummy loads	N/A	
Dielectric Withstanding Voltage (VRMS minimum at Sea level)†	Connectors for RG-178	750	
	Connectors for RG-316, RG-58, .086 Semi Rigid, Uncabled Receptacles, Adapters	1000	
	Dummy Loads	N/A	
Corona Level (Volts minimum at 70,000ft)†	Connectors for RG-178	185	
	Connectors for RG-316, RG-58, .086 Semi Rigid	250	
	Uncabled Receptacles, Adapters, Dummy Loads	N/A	
Insertion Loss (dB maximum, tested at 1.5 GHz)	Straight Cable Connectors	0.30 dB	
	Right Angle Cable Connectors	0.60 dB	
	Uncabled Receptacles, Adapters, Dummy Loads	N/A	
Insulation Resistance	1000 megohms minimum		
Contact Resistance (milliohms max)		Initial	After Environmental
	Center Contact (straight cabled connectors and uncabled receptacles)	6.0	8.0
	Center Contact (right angle cabled connectors and adapters)	12.0	16.0
	Outer Contact (Gold plated connectors)	1.0	1.5
	Outer Contact (Nickel plated connectors)	2.5	3.5
	Braid to Body (Gold plated connectors)	1.0	N/A
	Braid to Body (Nickel plated connectors)	2.5	N/A
RF Leakage (dB minimum tested at 2.5 GHz)	Cable Connectors	-55 dB	
	Uncabled Receptacles, Adapters, Dummy Loads	N/A	
RF High Potential Withstanding Voltage (VRMS minimum, tested at 4 and 7 MHz)†	Connectors for RG-178	500	
	Connectors for RG-316, RG-58	700	
	Uncabled Receptacles and Adapters	600	
	Dummy Loads	N/A	
Power Rating (Dummy Load)	0.5 watt @ +25°C, derated to 0.25 watt @ +125°C		

† Avoid user injury due to misapplication. See safety advisory definitions inside front cover.

50 Ohm SMB PC Mount Straight Jack Receptacle



Mechanical Ratings

Engagement Design	MIL-C-39012, Series SMB		
Engagement / Disengagement Force	2lbs min to 14lbs max axial force		
Contact Retention	4lbs min axial force (captivated contacts)		
	1 inch-ounce min torque (uncabled receptacles)		
Cable Retention		Axial Force* (pounds)	Torque (in-oz)
	Connectors for RG-178	10	N/A
	Connectors for RG-316	20	N/A
	Connectors for RG-58	40	16
	Connectors for .086 Semi-Rigid	30	16
Durability	500 Cycles minimum		

* Or cable breaking strength, whichever is less

Environmental Ratings

(Meets or exceeds the applicable paragraph of MIL-C-39012)

Temperature Range	Connectors	-65°C to +165°C
	Dummy Loads	-65°C to +125°C
Thermal Shock	MIL-STD-202, Method 107, Condition B (N/A Dummy Loads)	
Corrosion	MIL-STD-202, Method 101, Condition B (N/A Dummy Loads)	
Shock	MIL-STD-202, Method 213, Condition B (N/A Dummy Loads)	
Vibration	MIL-STD-202, Method 204, Condition B (N/A Dummy Loads)	

Material Specifications

Bodies	Brass per QQ-B-626 or Zinc per ASTM B86-71, Gold Plated** per MIL-G-45204 .00001 min or Nickel Plated per QQ-N-290
Contacts	Male - Brass per QQ-B-626, Gold Plated per MIL-G-45204 .00003" min. Female - Beryllium Copper per QQ-C-530, Gold Plated per MIL-G-45204 .00003" min
Insulators	PTFE Fluorocarbon per ASTM D 1710 and ASTM D 1457 or Teflon PFA 340
Expansion Caps	Brass per QQ-B-613, Gold Plated per MIL-G-45204 .00001" min. or Nickel Plated per QQ-N-290
Crimp Sleeves	Copper per WW-T-799, Gold Plated per MIL-G-45204 .00001" min. or Nickel Plated per QQ-N-290
Mounting Hardware	Brass (nuts) per QQ-B-626 or Phosphor Bronze (lockwashers) QQ-B-750, Gold Plated per MIL-G-45204 .00001" min. or Nickel Plated per QQ-N-290
Cover Rings	Phosphor Bronze per QQ-B-750, Gold Plated per MIL-G-45204 .00001 min. or Nickel Plated per QQ-N-290.

** All gold plated parts include a .00005" min. nickel underplate barrier layer



Asia Pacific
+86 21 5442 7668
ccs.asia.sales@as.cinch.com

Europe, Middle East & Africa
+44 (0) 1245 342060
CinchConnectivity@eu.cinch.com

North America
+1 630 705 6000
inquiry@us.cinch.com

belfuse.com/cinch

X-ON Electronics

Largest Supplier of Electrical and Electronic Components

Click to view similar products for [RF Connectors / Coaxial Connectors](#) category:

Click to view products by [Bel Fuse](#) manufacturer:

Other Similar products are found below :

[8915-1511-000](#) [89674-0827](#) [6001-7071-019](#) [6002-7051-003](#) [6002-7551-202](#) [6059674-1](#) [619550-1](#) [630059-000](#) [M39030/3-01N](#) [6500-7071-046](#) [6769](#) [CX050L2AQ](#) [7002-1541-010](#) [7002-1542-011](#) [7004-1512-000](#) [7009-1511-004](#) [7010-1511-000](#) [7029-1511-060](#) [7101-1541-010](#) [7101-1571-002](#) [7145-1521-002](#) [7203-1571-003](#) [7209-1511-011](#) [7210-1511-015](#) [7210-1511-019](#) [73137-5015](#) [73216-2241](#) [73404-2300](#) [7405-1521-005](#) [7405-1521-802](#) [8527](#) [8547](#) [FS11V](#) [877931](#) [9049-9513-000](#) [9074-9513-000](#) [9101-9573-002](#) [910A205F](#) [9130-9573-002](#) [PL11SC-026](#) [PL375-33](#) [PL40-5](#) [PL74C-221](#) [PL75MC-217](#) [PL803-7](#) [980-8666-005](#) [1200690078](#) [1-201144-1](#) [R107003010W](#) [R110A172100](#)