

MODEL NO.	PACKAGING
134-1000-014	ONE PCS PER BAG

REV	ECO	DATE
001	ECO-17-002	11/28/2017

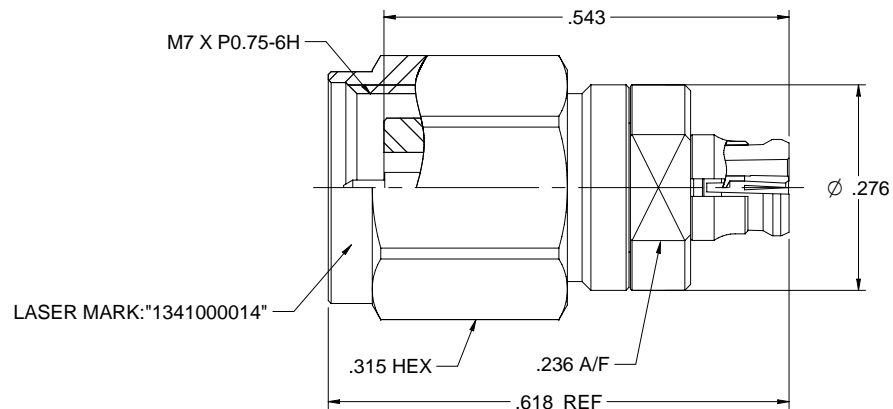

NOTES: UNLESS OTHERWISE SPECIFIED

1. MATERIAL & FINISH:

- 1.1 BODY & SHELL: PASSIVATED STAINLESS STEEL
- 1.2 CONTACT PIN,C RING & CONTACT BODY: GOLD PLATED BERYLLIUM COPPER
- 1.3 INSULATOR: ULTEM 1000 AMBER
- 1.4 C RING: BERYLLIUM COPPER
- 1.5 GASKET: SILICONE RED

2. ELECTRICAL:

- 2.1 IMPEDANCE: 50 OHMS
- 2.2 FREQUENCY RANGE: 0-40 GHz
- 2.3 VOLTAGE STANDING WAVE RATIO: 1.25 MAX
- 2.4 CONTACT RESISTANCE: CENTER CONTACT: 6 MILLIOHMS MAX
OUTERR CONTACT: 2.5 MILLIOHMS MAX
- 2.5 DIELECTRIC WITHSTANDING VOLTAGE: 500 VRMS MIN
- 2.6 INSULATION RESISTANCE: 5000 MOHM MIN

3. MECHANICAL:

- 3.1 ENGAGEMENT FORCE: 0.23 NM MAX (2.4MM)
FULL DETENT: 68 N MAX, LIMITED DETENT: 45 N MAX, SMOOTH BORE: 9 N MAX (SMP)
- 3.2 DISENGAGEMENT FORCE: 0.23 NM MAX (2.4MM)
FULL DETENT: 22 N MAX, LIMITED DETENT: 9 N MAX, SMOOTH BORE: 2.2N MAX (SMP)
- 3.3 CONTACT RETENTION: 20 N MIN
- 3.4 COUPLING PROOF TORQUE: 1.65 NM MIN
- 3.5 COUPLING NUT RETENTION: 267 N MIN
- 3.6 DURABILITY: 500 CYCLES MIN (2.4MM)
FULL DETENT: 100 CYCLES MIN, LIMITED DETENT: 500 CYCLES MIN, SMOOTH BORE: 1000 CYCLES MIN (SMP)

4. ENVIRONMENT:

- 4.1 THERMAL SHOCK: MIL-STD-202, METHOD 107, CONDITION B.
- 4.2 OPERATING TEMPERATURE: -55 TO 125°C
- 4.3 SALT SPRAY: MIL-STD-202, METHOD 101, CONDITION B
- 4.4 SHOCK: MIL-STD-202, METHOD 213, CONDITION I
- 4.5 VIBRATION: MIL-STD-202, METHOD 204, CONDITION D
- 4.6 MOISTURE RESISTANCE: MIL-STD-202, METHOD 106

	Model No. 134-1000-014	Johnson
	Date: 10/27/2017	Sheet 1 of 1
	Size: C	Rev: 001
	DO NOT SCALE DRAWING	Sheet 1 of 1

X-ON Electronics

Largest Supplier of Electrical and Electronic Components

Click to view similar products for [RF Adapters - Between Series category:](#)

Click to view products by [Bel Fuse manufacturer:](#)

Other Similar products are found below :

[5945-9503-000](#) [MCX/F-SMA/M](#) [R192417010](#) [ADBJ20-E1-BJ379](#) [ADM2](#) [ADPL75-A1-PL75](#) [242191](#) [9317505](#) [29-3835P](#) [AD130](#) [ADBJ20-E1-PL74](#) [ADBJ20-E2-BJ79](#) [ADBJ77-E1-UPL20](#) [ADRMF370](#) [242215](#) [242228](#) [R125680000W](#) [R192430000](#) [UAD95](#) [1057367-1](#) [8311505](#) [R114704000](#) [R451034500](#) [R451030500](#) [R451543000](#) [HDVDPN](#) [ADBJ20-K1-PL20](#) [R451570000](#) [R192419000](#) [R451034000](#) [J9](#) [J3WE-5](#) [R451032500](#) [242201RP](#) [17K132-K00S5](#) [AD-RSMAF-RTNC](#) [53K156-K00N5](#) [02K119-K00E3](#) [29S132-K01N5](#) [53S156-K00N5](#) [02S119-S00E3](#) [28K132-K00N5](#) [02S109-K00S3](#) [27-8200TP](#) [242235](#) [ADBJ20-E1-BJ89](#) [000-2900](#) [321-102-003 \(SMA-50/2-H155/W1.03 AU\)](#) [1057377-1](#) [321-350-001 \(SMA-50-R/2-RG316/N2.01\)](#)