

PRODUCT CATALOG

RF & Microwave Connectors & Cable Assemblies



EMERSON
Network Power

Johnson
Connectivity Solutions

Emerson Network Power Connectivity Solutions has a wide range of cable assemblies and connectors suited for RF, Microwave and Fiber Optic signal transmission. Connectivity Solutions is a vertically integrated supplier of custom, fixed length and semi-rigid cable assemblies from DC to 50 GHz. Our product lines deliver custom-engineered products and solutions to satisfy the most demanding and complex requirements.

AIM-Cambridge

Connectivity Solutions



AIM-Cambridge has a universal line of products that offer cost effective, high quality solutions for connectivity. Our connectors are available in BNC, Type N, F Type, RCA, UHF, Mini-UHF, TNC, D-Sub and Modular Plugs for Data/Telecom applications. In addition, we stock a wide variety of cables for A/V, SATV, CATV, computer and LAN applications, as well as a complete line of termination tools and structured cabling products. AIM-Cambridge promises that its product will provide you with unmatched consistency, quality, reliability and ease of use.

Johnson

Connectivity Solutions



Johnson designs and manufactures an industry leading line of RF coaxial connectors and adapters, which are available in both 50 and 75 ohm versions. Johnson connectors are designed to provide the highest quality data transmission for audio, video and data applications. The Johnson line of products can address frequency ranges from DC to 46GHz and all sizes from Ultra-miniature interfaces (UMC), Micro-miniature, (MCX, MMCX, SMP), Subminiature (SMA, SMB, SMK, kwiQMate™), Medium connectors (Type N connectors) through to large connectors (DIN7/16). The breadth of products available within the Johnson range includes board and cable mount connectors as well as semi-rigid, conformable, and flexible RF coaxial cables.

Midwest Microwave

Connectivity Solutions



Midwest Microwave manufacturers passive coaxial microwave components that are known for their precision performance and high quality that meets the precise requirements of the RF/Microwave industry. Our broad product portfolio includes: Attenuators, Precision Adapters, Terminations, DC Blocks, Power Dividers, Couplers, Equalizers, Phase Shifters, Connectors, Custom Cable Assemblies and Test Cables that are designed and manufactured for both military and commercial applications.

Midwest also offers a wide variety of Qualified Product List (QPL) approved products in the M3933, M39030 and M39012 series, as well as many DESC/DSCC approved models.

Semflex

Connectivity Solutions



Semflex designs and manufactures low loss, flexible, microwave coaxial cable and custom cable assemblies for the military/aerospace, commercial OEM and test instrumentation markets. Semflex offers cables ranging from DC to 50 GHz, available with ultra low insertion loss, power ratings up to 21 KW, and available with all popular connectors.

Stratos

Connectivity Solutions



Stratos optical connectivity products is globally recognized as highly reliable, cost-effective, and provides optical connectivity solutions that are virtually immune to dust, mud, oil, water, and other contaminants.

Our expanded beam connectivity products are ideal for harsh environment applications in the broadcast, industrial, petrochemical and military/aerospace markets where high reliability, low maintenance and quick serviceability are critical requirements. Our optical active products are used mainly in military, aerospace and industrial markets where high speed/high reliable performance is mission critical. The actives product line includes optical transceivers, optical media converters and custom devices tailored to your application.

Trompeter

Connectivity Solutions



Trompeter is recognized as a global leader in delivering best in class RF connectivity products. The Trompeter line of patch jacks, RF connectors, cable assemblies, HDTV digital technology and DS3 connectivity solutions is unrivalled. Our mission is to provide products that continually deliver the highest quality signal integrity for the most demanding applications in Telecom, Central Office, Broadcast, Military Aerospace, and Instrumentation markets worldwide. Our extensive line of cost-effective products are rigorously designed and tested to provide the critically engineered solutions necessary to enhance the end-user's overall experience.

Vitelec

Connectivity Solutions



Vitelec provides a comprehensive range of RF coaxial interconnect products and cable assemblies. The company has a long established reputation for offering quality and innovation with a wide range of both standard and custom designed products for the electronic and communication industries.

Specifications

Electrical Specifications

Impedance: 50 Ohms

Frequency Range:

Connectors	0-6 GHz
Dummy loads.....	0-1 GHz

VSWR (max): (f = GHz)

	<u>Straight Cable Connectors</u>	<u>Right Angle Cable Connectors</u>
.047 OD	1.20	1.14 + .07f
RG-178, RG-316, RG-316 DS	1.20	1.25
RG-405	1.15	1.15
Uncabled receptacles, dummy loads		N/A

Working Voltage:

Connectors	170 VRMS at sea level†
Dummy loads.....	N/A

Dielectric Withstanding Voltage:

Connectors... ..	500 VRMS at sea level†
Dummy loads.....	N/A

Insulation Resistance: 1000 megohms min

Contact Resistance: (milliohms max)

	<u>Initial</u>	<u>After Environmental</u>
Center contact (straight cabled connectors and uncabled receptacles)	5.0	8.0
Center contact (right angle cabled connectors).....	5.0	15.0
Outer contact (all connectors).....	1.0	1.5
Braid to body	1.5	N/A

Corona Level:

Connectors	190 volts min at 70,000 feet†
Dummy loads.....	N/A

Insertion Loss: (dB max, tested at 1 GHz)

Straight cabled connectors	0.1
Right angle cabled connectors.....	0.2
Uncabled receptacles, dummy loads.....	N/A

RF Leakage: (dB min, tested at 2.5 GHz)

Flexible cable	-60 dB
RG-405	-70 dB
Dummy loads	N/A

RF High Potential Withstanding Voltage: (400 VRMS at 4 and 7 MHz)†

Power Rating (Dummy Load): 0.5 watt @ +25°C, derated to 0.25 watt @ +125°C

†Avoid user injury due to misapplication. See safety advisory definitions inside front cover.

Mechanical Specifications

Engagement Design: Series MMCX

Engagement/Disengagement Force: 8 lbs max axial engagement
1.4 lbs min axial disengagement

Contact Retention: 2.0 lbs min axial force

Cable Retention:

	<u>Axial Force* (lbs)</u>	<u>Torque (oz-in)</u>
.047 flexible	3.5	N/A
RG-178	7.0	N/A
RG-316	20.0	N/A
RG-316 DS	25.0	N/A
RG-405	30.0	16

*Or cable breaking strength whichever is less.

Durability: 500 cycles min

Semi-Rigid and Flexible Cable

Right Angle Solder Type Plug – Captivated Contact

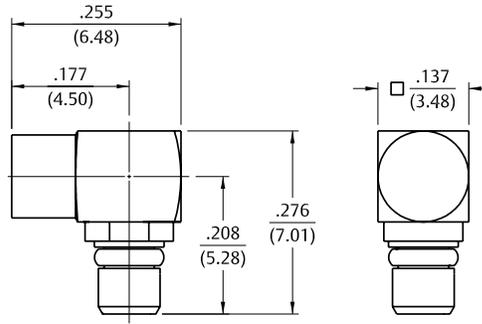

Cable Type	Gold Plated
RG-405	135-3693-101

Assembly instructions page 198.

Right Angle Crimp Type Plug – Captivated Contact

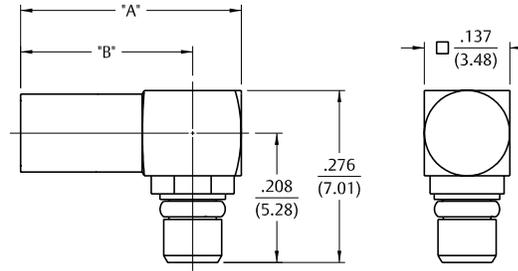

Cable Type	Gold Plated	"A"	"B"	Termination
.047" OD Flexible	135-3436-101	.354 (8.99)	.276 (7.01)	Crimp Insert
RG-178, 196	135-3402-101	.354 (8.99)	.276 (7.01)	Crimp Insert
RG-178, 196	135-3402-111	.412 (10.46)	.334 (8.48)	Crimp Sleeve
RG-316, 188, 161, 174, 179, 187	135-3403-101	.412 (10.46)	.334 (8.48)	Crimp Sleeve
RG-316 DS, 188 DS	135-3404-101	.412 (10.46)	.334 (8.48)	Crimp Sleeve

Assembly instructions page 200 and 201.

PC Mount

Right Angle Jack Receptacle



Gold Plated	"A"
135-3701-301	.115 (2.92)
135-3701-311	.068 (1.73)

Mounting Hole layout figure 12 page 194.

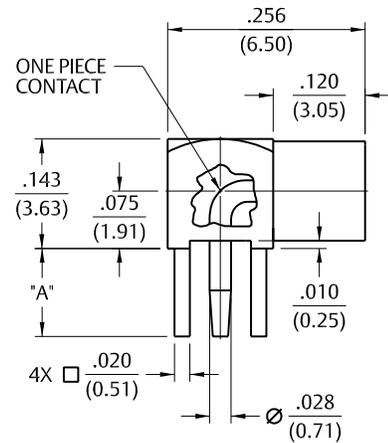

Straight Jack Receptacle



Gold Plated	"A"
135-3701-201	.115 (2.92)
135-3701-211	.068 (1.73)

Mounting Hole layout figure 12 page 194.

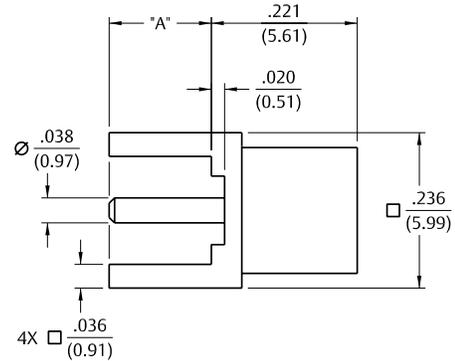

Straight Surface Mount Jack Receptacle



Gold Plated	Packaging
135-3711-201	Stock
135-3711-202	Tape and Reel, 1500 pcs/reel

Recommended Land Pattern figure 15 page 195.
Tape and Reel .315 (8.0) component pitch .630 (16.0) wide.

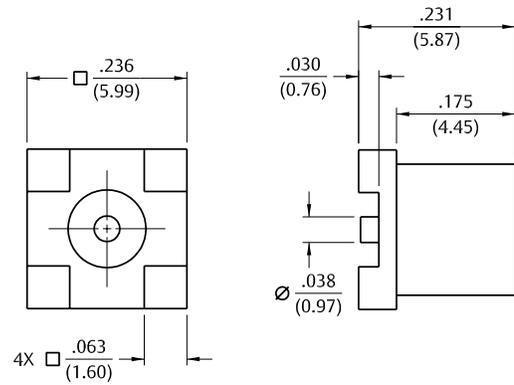

Non-Magnetic RF Connectors

Non-Magnetic Connectors

Our line of non-magnetic connectors is one of many successful examples of how Johnson® commercializes the high-end, custom application into the cost-sensitive solution that maintains the original Mil-Spec performance. As MRI and other magnetically sensitive technologies grow and evolve so to must the Johnson connector portfolio. Stronger magnetic fields, demands for better signal-to-noise ratios, custom-sized and modular flex coils for increasingly smaller machines: the RF connectors within the equipment have to bear an increasingly tricky role of delivering higher through-put while creating less interference.

With SMA, SMB, MCX, MMCX and soon SMP interfaces made available in a variety of PC and Cable-Mount designs, we can deliver the imaging performance your customers count on.

- The materials and finishes of our connectors meet the stringent limits of image and magnetic field distortion in an MR environment.
- The connector electrical performance exceeds the frequency requirements of the Receive/Transmit RF Coils in MR equipment (typically DC-6 GHz).
- The copper alloys of the body, springs and contact parts are designed to provide uniformity and maintain low permeability and magnetic susceptibility.
- Gold finishes are altered to eliminate magnetic barrier layers and provide excellent corrosion resistance and wear characteristics.
- Plugs maintain their electrical and mechanical performances in the environments of high-vibration common with MRI machines.
- A robust connector assembly design allows for a high count of mating cycles.
- As a helpful visual cue the connectors are marked “NM”.



Emerson Connectivity Solutions Non-Magnetic design capabilities expand beyond the parts and interfaces listed in this catalog. Please contact technical support to discuss the options for manufacturing your customized interconnects.

Flexible Cable and PC Mount

Right Angle Crimp Type Plug – Captivated Contact

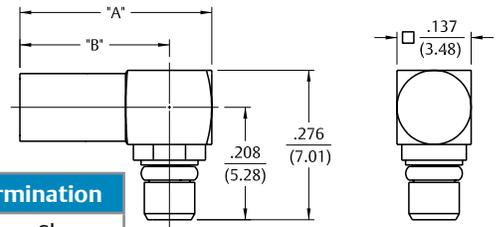

Cable Type	Gold Plated	"A"	"B"	Termination
RG-316, 188, 187, 179, 161, 174	135-9403-101	.412 (10.46)	.334 (8.48)	Crimp Sleeve
RG-178, 196	135-9402-111	.412 (10.46)	.334 (8.48)	Crimp Sleeve
.047 OD Flexible	135-9436-101	.354 (8.99)	.276 (6.98)	Crimp Insert

Assembly instructions page 199 and 200.

Straight Crimp Type Plug – Solder or Crimp Contact – Captivated Contact

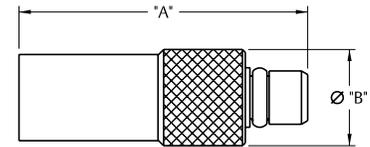

Cable Type	Gold Plated	"A"	"B"	Termination
RG-316, 188, 161, 174	135-9403-001	.509 (12.93)	.173 (4.39)	Crimp Sleeve
RG-178, 196	135-9402-001	.462 (11.73)	.137 (3.48)	Crimp Insert
.047 OD Flexible	135-9436-001	.462 (11.73)	.137 (7.01)	Crimp Insert

Assembly instructions page 204 and 205.

Straight Jack Receptacle



Gold Plated	"A"
135-9701-201	.115 (2.92)
135-9701-211	.068 (1.73)

Mounting hole layout figure 12 on page 195.

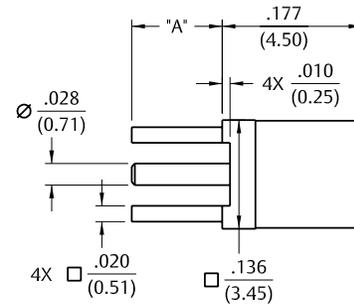

Right Angle Jack Receptacle



Gold Plated	"A"
135-9701-301	.155 (3.94)
135-9701-311	.068 (1.73)

Mounting hole layout figure 12 on page 195.

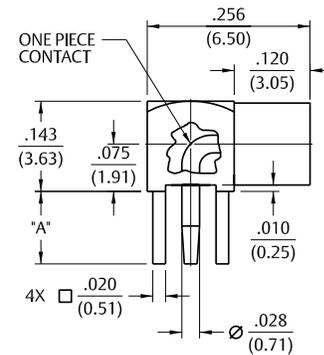

End Launch Surface Mount Jack Receptacle



Gold Plated	Packaging
135-9711-801	Stock
135-9711-802	Tape and Reel 1000 pcs/reel

Recommended land pattern figure 14 on page 195.
Tape and Reel .316 (8.0) component pitch .630 (16.0) wide.

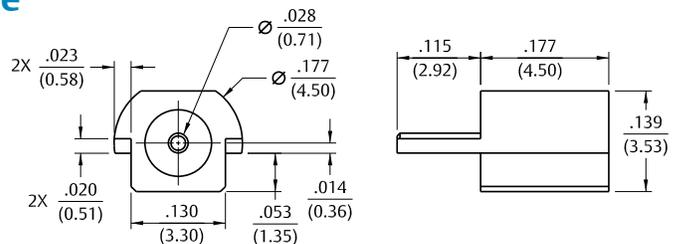

Specifications

Electrical Specifications

Impedance: 50 Ohms

Frequency Range:

Connectors.....	0-6 GHz
Dummy loads.....	0-1 GHz

VSWR: (max) (f = GHz)

	Straight Cabled Connectors	Right Angle Cabled Connectors
RG-178.....	1.17 + .04f	1.07 + .06f
RG-316 and RG-405.....	1.13 + .04f	1.07 + .04f
Adapters.....		1.13 + .04f
Uncabled receptacles, Dummy loads.....		N/A

Working Voltage: (VRMS max)†

	Sea Level	70K Feet
RG-178.....	250	65
RG-316, RG-405, uncabled receptacles, adapters.....	335	85
Dummy loads.....		N/A

Dielectric Withstanding Voltage: (VRMS min at sea level)†

RG-178.....	750
RG-316, RG-405, uncabled receptacles, adapters.....	1000
Dummy loads.....	N/A

Insulation Resistance: 1,000 megohms min

Contact Resistance: (milliohms max)

	Initial	After Environmental
Center contact (straight cabled connectors and uncabled receptacles).....	5.0	8.0
Center contact (right angle cabled connectors, adapters).....	5.0	15.0
Outer contact (all connectors).....	1.0	1.5
Braid to body (gold plated connectors).....	1.0	N/A
Braid to body (nickel plated connectors).....	2.5	N/A

Corona Level: (Volts min at 70,000 feet)

RG-178.....	190
RG-316, RG-405 uncabled receptacles, adapters.....	250
Dummy loads.....	N/A

Insertion Loss: (dB max tested at 1 GHz)

Straight cabled connectors, adapters.....	0.1 dB
Right angle cabled connectors.....	0.2 dB
Uncabled receptacles, dummy loads.....	N/A

RF Leakage: (dB min, tested at 2.5 GHz)

Cable connectors.....	-55 dB
Uncabled receptacles and adapters, dummy load.....	N/A

RF High Potential Withstanding Voltage: (VRMS min, tested at 4 and 7 MHz)†

RG-178.....	500
RG-316 and adapters.....	700
RG-405.....	670
Uncabled receptacles.....	600
Dummy loads.....	N/A

Power Rating (Dummy Load): 0.5 watt @ +25°C, derated to 0.25 watt @ +125°C

† Avoid user injury due to misapplication. See safety advisory definitions inside front cover.

Mechanical Specifications

Engagement Design: Compatible with CECC 22220, Series MCX

Engagement Force: 5.6 lbs max axial force

Disengagement Force: 8 lbs max axial force, 1 lb min

Contact Retention: 2.3lbs min axial force (captivated contacts) 1 oz-in min torque (uncabled receptacles)

	Axial Force* (lbs)	Torque (oz-in)
RG-178.....	10.0	N/A
RG-316.....	20.0	N/A
RG-316 DS.....	25.0	N/A
RG-405.....	30.0	16

*Or cable breaking strength whichever is less.

Durability:.....500 cycles min

Semi-Rigid Cable & Flexible Cable

Straight Solder Type Plug

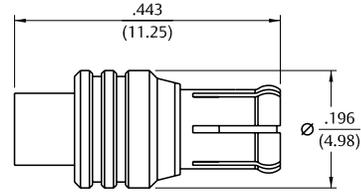

Cable Type	Gold Plated	Nickel Plated
RG-405	133-3693-001	133-3693-006

Assembly instructions page 206.

Right Angle Solder Type Plug – Captivated Contact

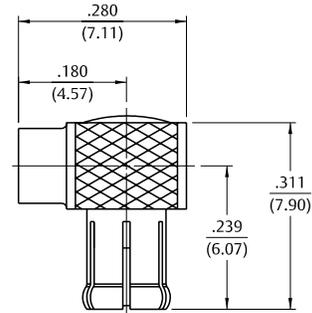

Cable Type	Gold Plated	Nickel Plated
RG-405	133-3693-101	133-3693-106

Assembly instructions page 206.

Straight Crimp Type Plug – Solder or Crimp Contact

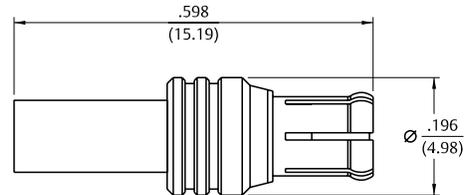

Cable Type	Gold Plated	Nickel Plated	Captivated Contact
RG-178, 196	133-3402-001	133-3402-006	No
RG-316, 188, 161, 174	133-3403-001	133-3403-006	Yes
RG-316 DS, 188DS	133-3404-001	133-3404-006	Yes
RG-179, 187	133-3433-001	133-3433-006	Yes

Assembly instructions page 207.

PC Mount

Straight Plug Receptacle



Gold Plated	Nickel Plated
133-3801-201	133-3801-206

Mounting hole layout figure 4 page 194.

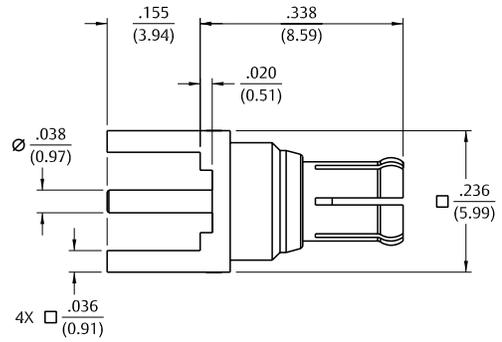

Straight Plug Receptacle – Low Profile



Gold Plated	Nickel Plated
133-3801-211	133-3801-216

Mounting hole layout figure 4 page 194.

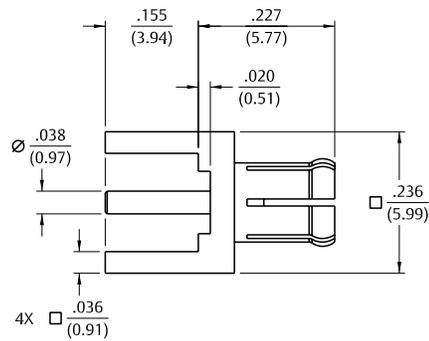

Straight Jack Receptacle



Gold Plated	Nickel Plated	"A"
133-3701-201	133-3701-206	.155 (3.94)
133-3701-211	133-3701-216	.110 (2.79)
133-3701-221	133-3701-226	.068 (1.73)

Mounting hole layout figure 4 page 194.

Four and six connector ganged receptacles available. See page 190.

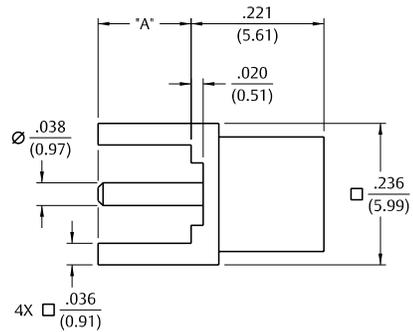

PC Mount

Right Angle Jack Receptacle



Gold Plated	Nickel Plated	"A"
133-3701-301	133-3701-306	.155 (3.94)
133-3701-311	133-3701-316	.110 (2.79)
133-3701-321	133-3701-326	.068 (1.73)

Mounting hole layout figure 4 page 194.

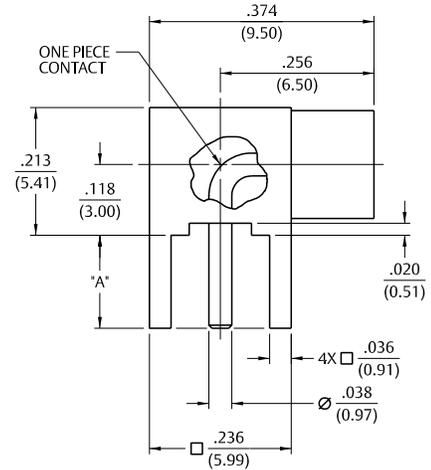

Right Angle Surface Mount Jack Receptacle



Gold Plated	Packaging
133-3711-301	Stock
133-3711-302	Tape and Reel 750 pcs/reel

Recommended land pattern figure 13 on page 195.
Tape and Reel .472 (12.0) component pitch .945 (24.0) wide.

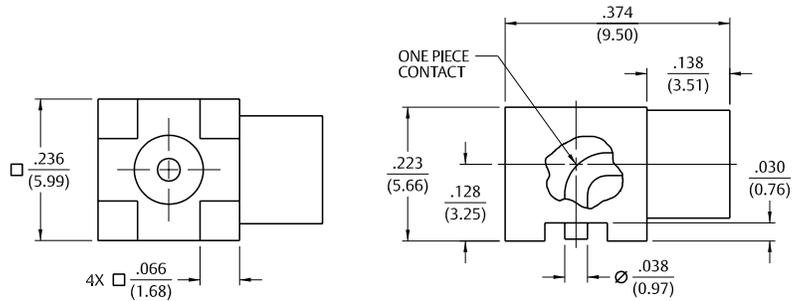

Right Angle Surface Mount Jack Receptacle



Gold Plated	Packaging
133-3711-311	Stock
133-3711-312	Tape and Reel 750 pcs/reel

Recommended land pattern figure 4 on page 194.
Tape and Reel .472 (12.0) component pitch .945 (24.0) wide.

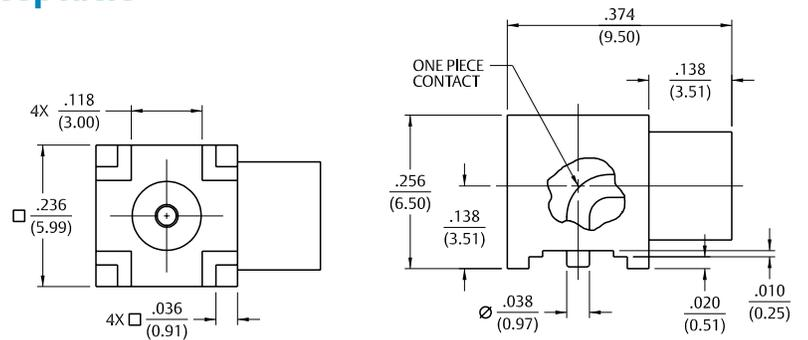

PC Mount, Bulkhead Mount & Panel Mount

End Launch Surface Mount Jack Receptacle



Gold Plated	Packaging
133-3711-801	Stock
133-3711-802	Tape and Reel 1000 pcs/reel

Recommended land pattern figure 21 page 195.
Tape and Reel .472 (12.0) component pitch .945 (24.0) wide

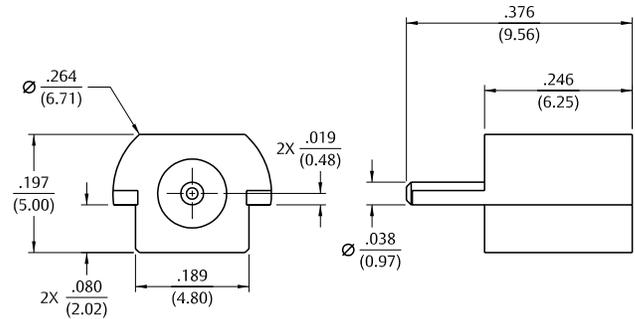

Front Mount Bulkhead Jack Receptacle



Gold Plated	Nickel Plated	Mounting Style	Fig
133-3701-401	133-3701-406	D Flat Threaded	1
133-3701-411	133-3701-416	Press Fit Knurl	2

Mounting hole layout for 133-3701-401 figure 5 page 194.
Mounting hole layout for 133-3701-406 figure 5 page 194.
Mounting hole layout for 133-3701-411 figure 10 page 194.
Mounting hole layout for 133-3701-416 figure 10 page 194.

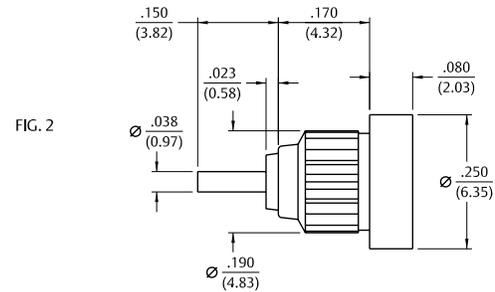
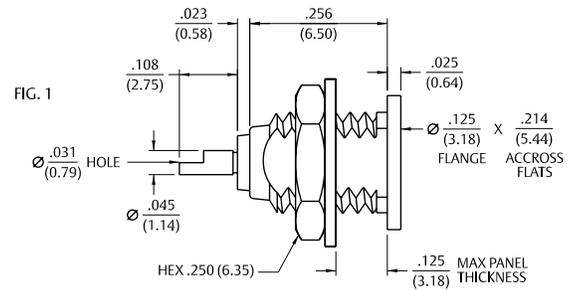

2-Hole Flange Mount Jack Receptacle – Flush Dielectric



Gold Plated	Nickel Plated
133-3701-601	133-3701-606

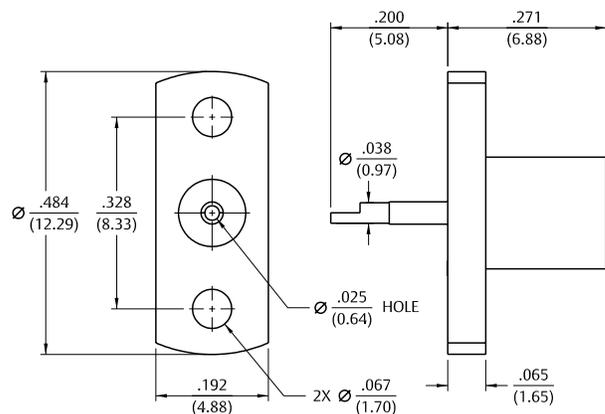

Flexible Cable

Straight Crimp Type Plug – Solder or Crimp Contact

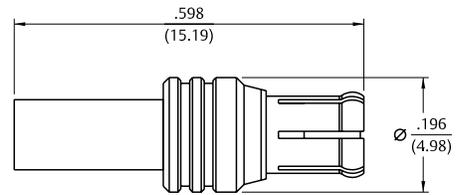

Cable Type	Gold Plated	Nickel Plated	Captivated Contact
RG-178, 196	133-5402-001	133-5402-006	No
RG-316, 188, 161, 174	133-5403-001	133-5403-006	Yes
RG-316 DS, 188 DS	133-5404-001	133-5404-006	Yes

Assembly instructions page 207.

Right Angle Crimp Type Plug – Captivated Contact

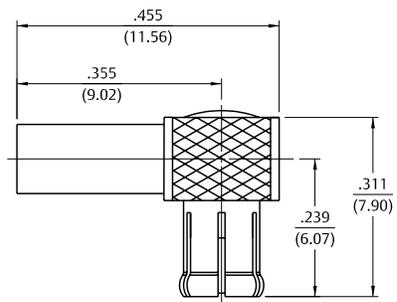

Cable Type	Gold Plated	Nickel Plated
RG-178, 196	133-5402-101	133-5402-106
RG-316, 188, 161, 174	133-5403-101	133-5403-106
RG-316 DS, 188 DS	133-5404-101	133-5404-106

Assembly instructions page 210.

Straight Crimp Type Bulkhead Jack – Solder or Crimp Contact

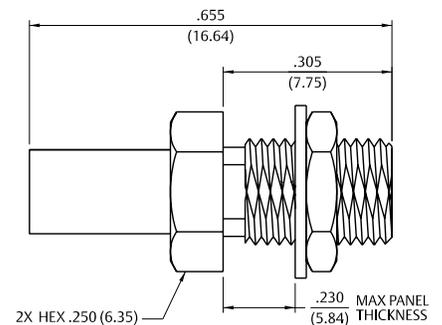

Cable Type	Gold Plated	Nickel Plated	Captivated Contact
RG-178, 196	133-5302-401	133-5302-406	No
RG-316, 188, 161, 174	133-5303-401	133-5303-406	Yes
RG-316 DS, 188 DS	133-5304-401	133-5304-406	Yes

Mounting hole layout figure 5 page 194.
 Assembly instructions page 207.

Specifications

Electrical Specifications

Impedance: 75 Ohms

Frequency Range: 0-6 GHz

VSWR: (max) (f=GHz)

	<u>Straight Cabled Connectors</u>	<u>Right Angle Cabled Connectors</u>
RG-179	1.13 + .04f	1.07 + .04f
In-series adapters	1.07 + .03f	
Between-series adapters, loads	1.05 + .01f	

Uncabled receptacles..... N/A

Working Voltage: (VRMS max)† Sea Level 70K Feet

RG-179

	335	85
--	-----	----

Uncabled receptacles, adapters

	335	85
--	-----	----

Loads, matching pad..... N/A

Dielectric Withstanding Voltage: (VRMS min at sea level)†

RG-179..... 1000

Uncabled receptacles, adapters..... 1000

Loads..... N/A

Insulation Resistance: 1,000 megohms min

Contact Resistance: (milliohms max)

	<u>Initial</u>	<u>After Environmental</u>
Center contact (straight cabled connectors and uncabled receptacles)	5.0	8.0
Center contact (right angle cabled connectors, adapters).....	10.0	15.0
Center contact (loads).....	N/A	
Outer contact.....	1.0	1.5
Braid to body (gold plated connectors).....	1.0	N/A

Corona Level: (Volts min at 70,000 feet) †

RG-179..... 250

Uncabled receptacles, adapters..... 250

Loads matching pad..... N/A

Insertion Loss: (dB max tested at 1 GHz)

Straight cabled connectors

	0.1 dB
--	--------

Right angle cabled connectors..... 0.2 dB

Uncabled receptacles, adapters..... N/A

RF Leakage: (dB min, tested at 2.5 GHz)

Cable connectors

	-55 dB typical
--	----------------

Uncabled receptacles, adapters, loads

	N/A
--	-----

RF High Potential Withstanding Voltage: (VRMS min, tested at 4 and 7 MHz)†

Cabled Connectors for RG-179

	700
--	-----

Uncabled receptacles, adapters..... 600

Loads..... N/A

Power Rating: (Loads) 1.0 Watt at +25°C, derated linearly to 0.5 Watts at +125°C

† Avoid user injury due to misapplication. See safety advisory definitions inside front cover.

Specifications

Mating Engagement for 75 Ohm MCX Series (Intermatable with CECC22220 50 Ohm MCX)

1. ID of contact to meet VSWR mating characteristics and connector durability when mated with a dia. .019-.021 (0.48-0.53) dia. male contact.
2. Must meet the force to engage and disengage when mated with mating part.
3. Interface shall intermate with MCX 50 Ohm interface per CECC 22220.

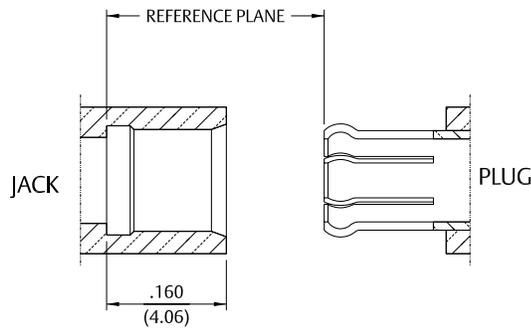
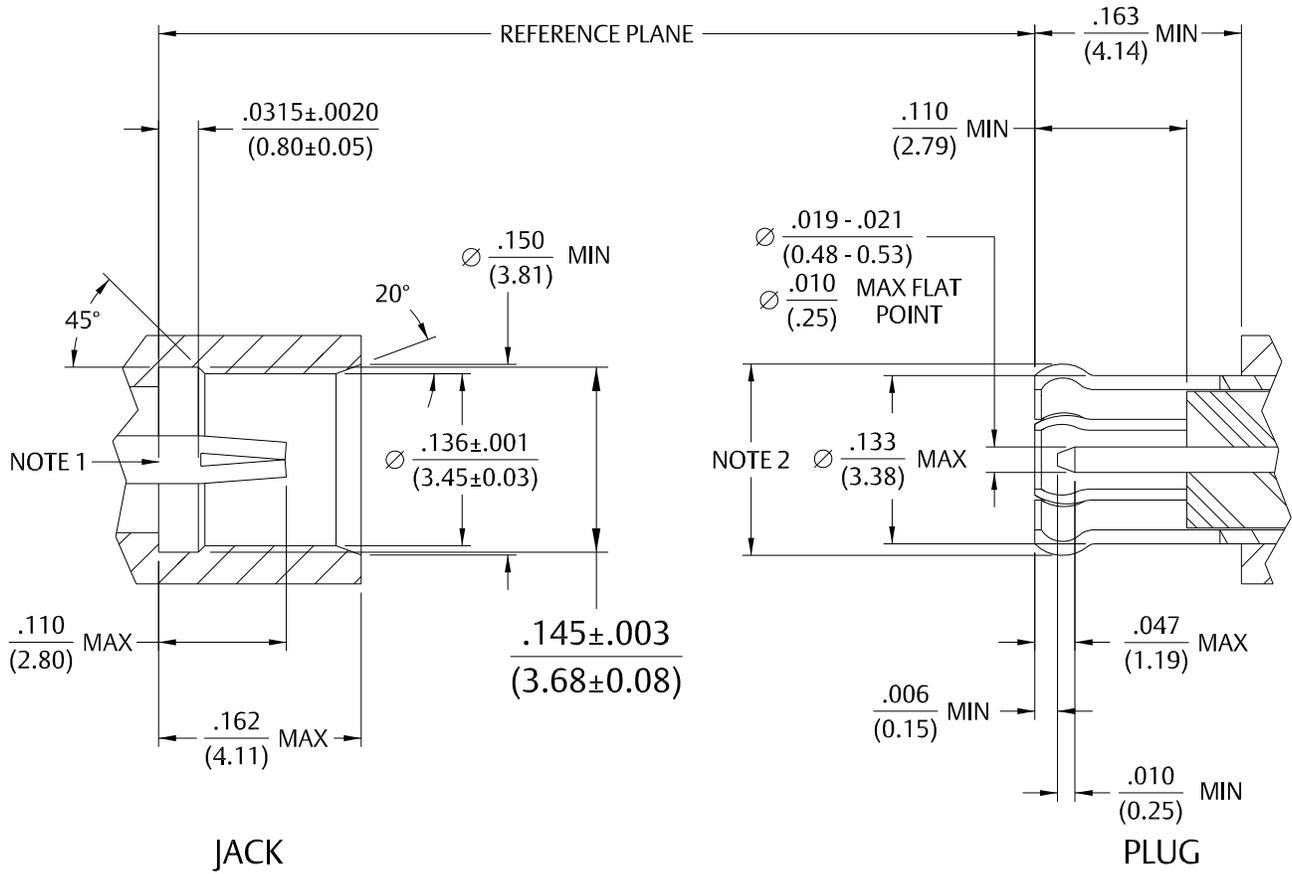

Flexible Cable & PC Mount

Straight Crimp Type Bulkhead Jack – Solder or Crimp Captivated Contact



Cable Type	Gold Plated
RG-179	133-8333-401
RG-179 DS	133-8334-401

Assembly instructions page 209.
Mounting hole layout figure 5 page 194.

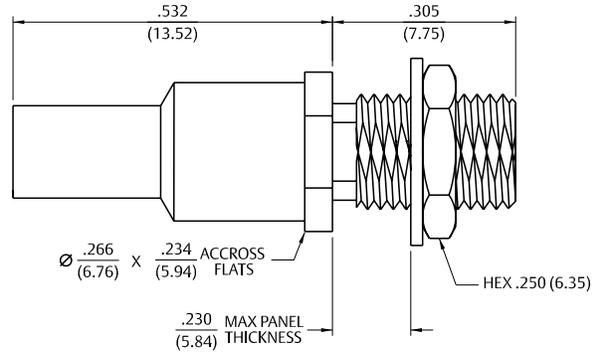

Straight Plug Receptacle



Gold Plated	"A"	"B"
133-8801-201	.155 (3.80)	.343 (8.71)
133-8801-211	.110 (2.70)	.343 (8.71)
133-8801-221	.155 (3.80)	.510 (12.95)

Mounting hole layout figure 20 page 195.

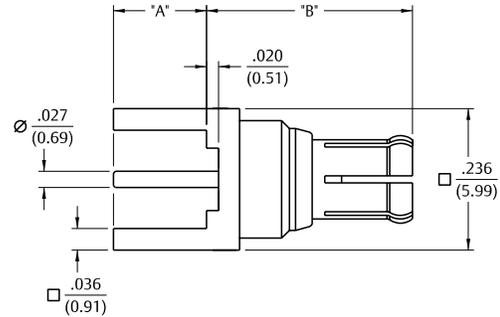

Straight Jack Receptacle



Gold Plated	"A"
133-8701-201	.155 (3.80)
133-8701-211	.100 (2.54)

Mounting hole layout figure 20 page 195.

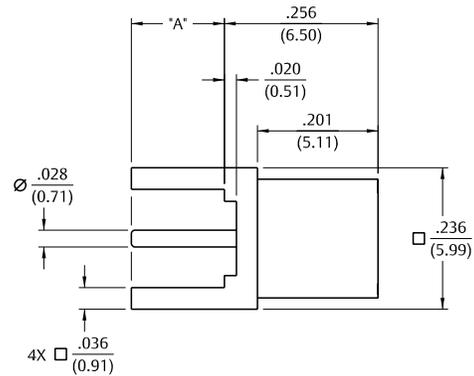

Surface Mount Jack Receptacle



Gold Plated	Packaging
133-8711-201	Bulk Packs
133-8711-202	Tape and Reel 770 pcs/reel

Mounting hole layout figure 11 page 194.
Tape and Reel .472 (12.0) component pitch .630 (16.0) wide.

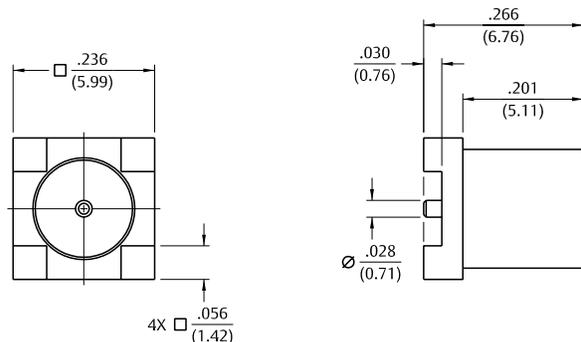

In-Series Adapters & Between Series Adapters

Jack to Plug Adapter



Gold Plated

133-8901-821

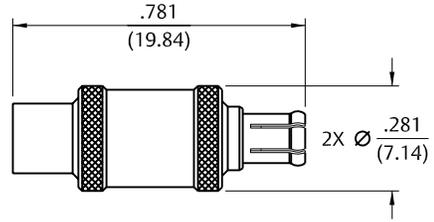

75 Ohm Type N Plug to 75 Ohm MCX Plug Adapter



Stainless Steel Passivated

134-1068-001

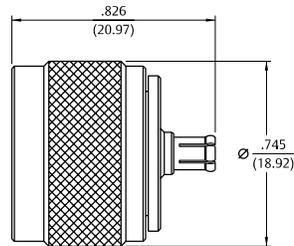

75 Ohm Type N Plug to 75 Ohm MCX Jack Adapter



Stainless Steel Passivated

134-1068-011

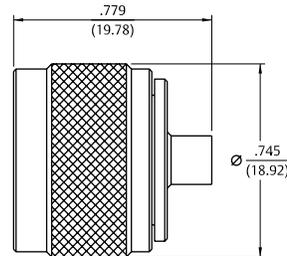

Specifications

Electrical Specifications

Impedance: 50 Ohms		
Frequency Range:		0-6 GHz
VSWR (max): (f=GHz)		
	<u>Straight</u>	<u>Right Angle</u>
	<u>Cabled Connectors</u>	<u>Cabled Connectors</u>
RG-316 cable.....	1.13 + .04f	1.07 + .04f
Uncabled receptacles.....		N/A
Working Voltage: (VRMS max)†	<u>Sea Level</u>	<u>70K Feet</u>
RG-316	335	85
Dielectric Withstanding Voltage: (VRMS min at sea level)†		
RG-316, uncabled receptacles		1000
Insulation Resistance: 1,000 megohms min		
Contact Resistance: (milliohms max)		After
	<u>Initial</u>	<u>Environmental</u>
Center contact (straight cabled connectors and uncabled receptacles).....	5.0	8.0
Center contact (right angle cabled connectors).....	5.0	15.0
Outer contact.....	1.0	1.5
Braid to body.....	1.0	N/A
Corona Level: (Volts min at 70,000 feet) †		
RG-316, uncabled receptacles		250
Insertion Loss: (dB max tested at 1 GHz)		
Straight cabled connectors		0.1 dB
Right angle cabled connectors		0.2 dB
Uncabled receptacles		N/A
RF Leakage: (dB min, tested at 2.5 GHz)		
Cabled connectors.....		-55 dB
Uncabled receptacles		N/A
RF High Potential Withstanding Voltage: (VRMS min tested at 4 and 7 MHz)		
Cabled Connectors		700
Uncabled receptacles		600

† Avoid user injury due to misapplication. See safety advisory definitions.

Mechanical Specifications

Engagement Design:	Compatible with CECC 22220, Series MCX 50 Ohm	
Engagement Force:	5.6 lbs max axial force	
Disengagement Force:	8 lbs max axial force, 1 lb min	
Contact Retention:	2.3 lbs min axial force (captivated contacts) 1 oz-in min torque (uncabled receptacles)	
	<u>Axial Force (lbs) *</u>	<u>Torque (oz-in)</u>
RG-316.....	20.0	N/A
RG-316 DS.....	25.0	N/A
*Or cable breaking strength whichever is less.		
Durability:		500 cycles min

Environmental Specifications

(Meets or Exceeds the Applicable Paragraph of MIL-PRF-39012)

Temperature Range:	- 65°C to + 165°C
Thermal Shock:	MIL-STD-202, Method 107, Condition F
Corrosion:	MIL-STD-202, Method 101, Condition B
Shock:	MIL-STD-202, Method 213, Condition B
Vibration:	MIL-STD-202, Method 204, Condition B
Moisture Resistance:	MIL-STD-202, Method 106

Material Specifications

(See non-magnetic materials page 10)

Non-Magnetic RF Connectors – For PC Mount

Straight Jack Receptacle



Gold Plated	"A"
133-9701-201	.155 (3.94)
133-9701-211	.110 (2.79)

Mounting hole layout figure 4 page 194.

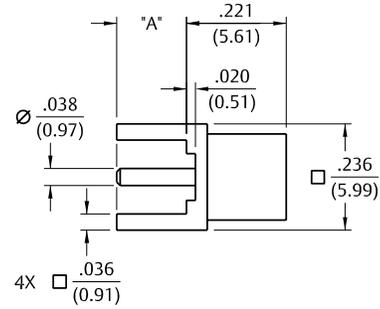

Straight Jack Receptacle – .100" Layout



Gold Plated
133-9701-231

Mounting hole layout figure 12 page 194.

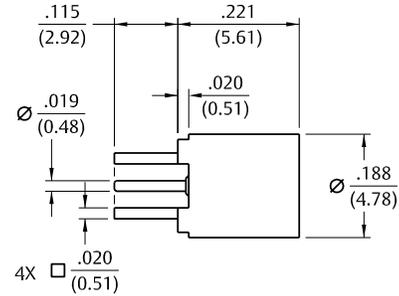

Right Angle Jack Receptacle



Gold Plated	"A"
133-9701-301	.155 (3.94)
133-9701-311	.110 (2.79)

Mounting hole layout figure 4 page 194.

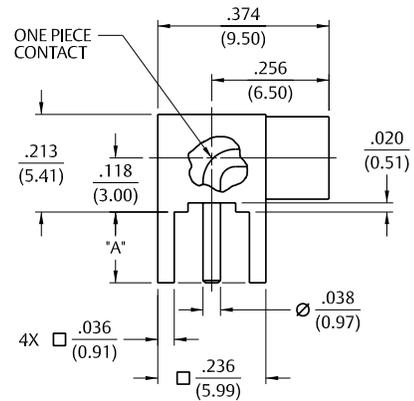

End Launch Jack Receptacle – Round Contact



Gold Plated	Board Thickness
133-9701-801	.062 (1.57)

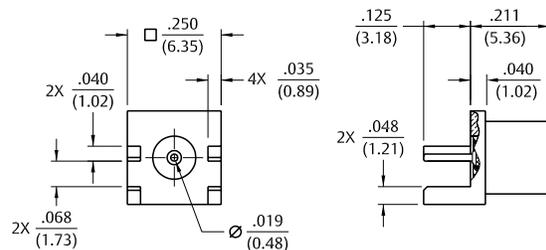

Specifications

SMK (2.92mm) Connectors

The Johnson line of SMK Connectors provides an excellent solution for demanding applications requiring high frequency transmission. Although similar to the SMA interface, a smaller internal body diameter (2.92mm) and air dielectric provide a higher cutoff frequency and other key advantages:

- Precision manufacturing allows superior electrical performance to 40 GHz
- Female contacts have a unique three-slot construction, which enhances connectivity by creating a more rugged connector while reducing the chance of intermittent connections
- Precise assembly tooling assures excellent, repeatable contact and support bead location on cabled connectors
- Connector mating interface per MIL-STD-348
- Mating interface control provides consistent electrical performance
- Plug connector VSWR is 1.20 Max to 40 GHz and a 12 inch SMK plug to plug cable assembly performs better than 1.35 VSWR to 40 GHz
- Field Replaceable Jacks are teamed with a high quality hermetic seal feed thru for use in sealed circuit modules
- SMK plug interface employs more precise dimensions than an SMA and uses a shorter snub nose male pin such that the connector bodies align before the contacts engage



Electrical Specifications

Impedance: 50 Ohms

Frequency Range: 0-40 GHz

VSWR (max): (f = GHz)

Semi-Rigid straight cabled connectors and adapters 1.20 max
 Field replaceable (see typical return loss graph)..... N/A

Working Voltage: (VRMS max)

Connectors for Cable Type	Sea Level	70K Feet
RG-405 and field replaceable.....	335	85
RG-402 and adapters.....	500	125

Dielectric Withstanding Voltage: (VRMS min at sea level)

RG-405 and field replaceable	1000
RG-402 and adapters	1500

Corona Level: (Volts min at 70,000 feet)

RG-405 and field replaceable.....	250
RG-402 and adapters.....	375

Insertion Loss: (dB max)

Adapters	0.06 f (GHz), tested at 6 GHz
Straight Semi-Rigid cable connectors	0.03 f (GHz), tested at 10 GHz

Insulation Resistance: 5000 megohms min

Contact Resistance: (milliohms max)	Initial	After Environmental
Center contact straight cabled connectors	3.0*	4.0
Center contact adapters.....	4.0	6.0
Field replaceable connectors	6.0	8.0
Outer contact (all connectors).....	2.0	N/A
Body to cable (gold plated connectors).....	0.5	N/A
Body to cable (passivated connectors).....	5.0	N/A

RF Leakage: (dB min, tested at 2.5 GHz) -90dB

RF High Potential Withstanding Voltage: (VRMS min., tested at 4 and 7 MHz)†

RG-405 and field replaceable.....	670
RG-402 and adapters.....	1000

Mechanical Specifications

Engagement Design:	MIL-STD-348, Series SMK (2.92mm)
Engagement/Disengagement Force:	2 lb-in max
Mating Torque:	7 to 10 in-lb
Bulkhead Mounting Nut Torque:	15 in-lb
Coupling Proof Torque:	15 in-lb min
Coupling Nut Retention:	60 lbs min
Contact Retention:	6 lbs min axial force (captivated contacts)

Cable Retention:	Axial Force* (lbs)	Torque (in-oz)
RG-405	30	16
RG-402	60	55

*Or cable breaking strength whichever is less

Durability: 500 cycles min

† Avoid user injury due to misapplication. See safety advisory definitions.

Specifications

Field Replaceable Application Notes

These field replaceable connectors are easy to install and replace. The hermetic seal is mounted into the circuit module wall and the connector can be removed and replaced without destroying the hermeticity of the circuit housing.

The field replaceable connector creates a transition from microstrip circuitry to a coaxial transmission line. The SMK (2.92mm) seal pin diameter is .012 (.030) to minimize the capacitive effects on the circuit trace. For optimum electrical performance, the transition from the hermetic seal to the microstrip trace must be properly compensated which involves adjusting the microstrip trace width to minimize any impedance discontinuities found in the transition area.

The plot shown below is representative of the typical return loss of a Johnson field replaceable SMK connector. To produce the data shown below, a test fixture is created using the Johnson SMK hermetic seal. The fixture consists of a suitably thick spacer plate with the hermetic seal mounted flush to both surfaces. Two connectors are mounted back to back around the fixture and the VSWR of this test assembly is measured. The calculated return loss trace shown is equivalent to the square root of the measured VSWR of the test assembly. Since the connectors tested are of identical design, it can be stated with fair accuracy that the calculated data shown represents the response of a single field replaceable connector and its transition to the hermetic seal.

Although we do not publish a VSWR specification for field replaceable connectors, typical connector return loss can be expected to be better than 20 dB through 40 GHz. A VSWR specification is not stated because an industry standard method for testing field replaceable connectors does not exist. The actual performance of the connector is dependent upon the following:

1. For optimum electrical performance, we recommend the use of our standard 142-1000-033 hermetic seal with a pin diameter of $.0120 \pm .0005$ (0.305 ± 0.013).
2. It is recommended that the hermetic seal be mounted flush with the circuit housing. Tolerance variations between the hermetic seal and machined housing do not always guarantee an optimum transition to the connector. Some manufacturers recommend an additional counterbore in the circuit housing to accommodate a solder washer during installation of the seal. We do not recommend this type of installation because, if the counterbore is not completely filled with solder, electrical discontinuities may be created.
3. The transition between the hermetic seal pin and the microstrip trace will effect electrical performance, as stated above. Several different methods of hermetic seal mounting and seal pin to microstrip trace attachment are used in the industry.

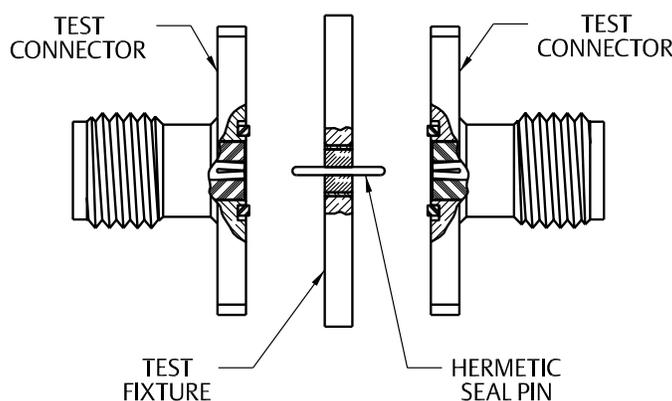

In-Series Adapters

Hermetic Seal Feedthru

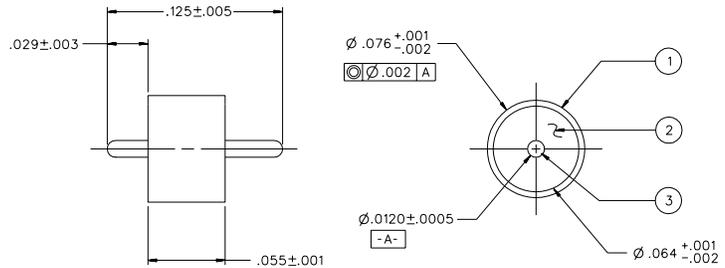

Part No.	Item 1 – Outer Ring	Item 2 – Insulator	Item 3 – Pin
142-1000-033	Kovar Gold Pl .00005 min over Nickel Pl .00005 min	Glass Corning 7070 Or Equivalent	Kovar Gold Pl .00005 min. over Nickel Pl .00005 min.

Notes:

1. The hermetic seal should be mounted as flush as possible with the housing. Excessive recession will create a high impedance air gap between connection and housing which degrades electrical performance.
2. The use of an additional counterbore to accommodate a solder ring for seal mounting is not recommended. A slight chamfer may be used if care is taken to completely fill the area with solder. **Avoid air gaps!**

Electrical

Impedance: 50 Ohms
Frequency Range: DC to 40 GHz
VSWR: Dependent upon application
Working Voltage: 250 VRMS max at sea level
Dielectric Withstanding Voltage: 500 VRMS min at sea level
Insulation Resistance: 5000 Megohm min
Insertion Loss: 0.2 dB max at 40 GHz

Environmental

Hermeticity: 1x10-8 cc/sec at one atmosphere
Solderability: MIL-STD-202, Method 209
Operating Temperature: -55° C to +165° C

Jack to Jack In-Series Adapter



Gold Plated
145-0901-801

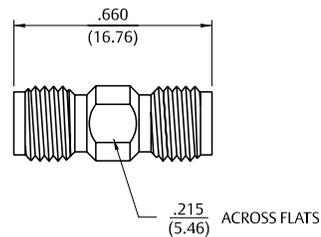

Plug to Plug In-Series Adapter



Gold Plated
145-0901-811

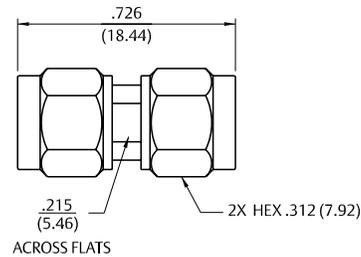

Plug to Jack In-Series Adapter



Gold Plated
145-0901-821

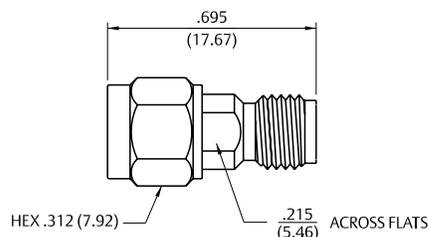

Specifications

Electrical Ratings

Impedance: 50 Ohms

Frequency Range:

Dummy loads	0-2.00 GHz
Flexible cabled connectors	0-12.4 GHz
Uncabled receptacles, Right Angle Semi-Rigid cabled connectors and adapters.....	0-18.0 GHz
Straight Semi-Rigid cabled connectors and field replaceable connectors	0-26.5 GHz

VSWR: (max) (f = GHz)

	Straight Cabled Connectors	Right Angle Cabled Connectors
RG-178.....	1.20 + .025f	1.20 + .03f
RG-316, LMR-100.....	1.15 + .02f	1.15 + .03f
RG-58, LMR-195.....	1.15 + .01f	1.15 + .02f
RG-142.....	1.15 + .01f	1.15 + .02f
LMR-200, LMR-240	1.10 + .03f	1.10 + .06f
RG-405.....	1.07 + .008f	1.18 + .015f
RG-402 (w/contact).....	1.05 + .008f	1.15 + .015f
RG-402 (w/o contact).....	1.035 + .005f	
Jack-bulkhead jack adapter and plug-plug adapter		1.05 + .010f
Jack-jack adapter and plug-jack adapter		1.05 + .005f
Uncabled receptacles, dummy loads.....		N/A
Field replaceable (see page 80).....		N/A

Working Voltage: (VRMS max)†

	Sea Level	70K Feet
RG-178	170	45
RG-316, LMR-100, 195, 200	250	65
RG-58, RG-142, LMR-240, RG-405, uncabled receptacles, RG-402 w/o contact.....	335	85
RG-402 with contact and adapters.....	500	125
Dummy loads		N/A

Dielectric Withstanding Voltage: (VRMS min at sea level)†

RG-178.....	500
RG-316, LMR-100, 195, 200	750
RG-58, RG-142, LMR-240, RG-405, field replaceable, uncabled receptacles.....	1000
RG-402 with contact and adapters.....	1500
RG-402 w/o contact, dummy loads.....	N/A

Insulation Resistance: 5000 megohms min

Contact Resistance: (milliohms max)

	Initial	After Environmental
Center contact (straight cabled connectors and uncabled receptacles)	3.0*	4.0*
Center contact (right angle cabled connectors and adapters)	4.0	6.0
Field replaceable connectors	6.0	8.0
Outer contact (all connectors).....	2.0	N/A
Braid to body (gold plated connectors)	0.5	N/A
Braid to body (nickel plated connectors).....	5.0	N/A

*N/A where the cable center conductor is used as a contact

Corona Level: (Volts min at 70,000 feet)†

RG-178	125
RG-316, LMR-100, 195, 200	190
RG-58, RG-142, LMR-240, RG-405, uncabled receptacles, RG-402 w/o contact.....	250
RG-402 with contact and adapters.....	375
Dummy loads.....	N/A

Specifications

Material Specifications

Bodies:	Brass per ASTM B16, gold plated* per MIL-DTL-45204 .00001" min. or nickel plated per SAE-AMS2423
Contacts:	Male - brass per ASTM B16, gold plated per MIL-DTL-45204 .00005" min Female - beryllium copper per ASTM B196, gold plated per MIL-DTL-45204 .00005" min
Nut Retention Spring:	Beryllium copper per ASTM B196, Unplated
Insulators:	PTFE fluorocarbon per ASTM D 1710 and ASTM D 1457 or Tefzel per ASTM D 3159 or PFA 340 per ASTM D 3307
Expansion Caps:	Brass per ASTM B36, gold plated per MIL-DTL-45204 .00001" min. or nickel plated per SAE-AMS2423
Crimp Sleeves:	Copper per ASTM B301 or brass per ASTM B16, gold plated per MIL-DTL-45204 .00001" min or nickel plated per SAE-AMS2423
Mounting Hardware:	Brass (nuts) per ASTM B16 or phosphor bronze (lockwashers), gold plated per MIL-DTL-45204 .00005" min or nickel plated per SAE-AMS2423
Seal Rings:	Silicone rubber per A-A-59588A
EMI Gaskets:	Conductive silicone rubber per MIL-G-83528, Type M

* All gold plated parts include a .00005" min. nickel underplate barrier layer

Mating Engagement for SMA Series

NOTES

1. ID to meet VSWR, contact resistance and insertion withdraw forces when mated with a dia. .0355-.0370 pin.
2. Gasket is not supplied with brass connectors.

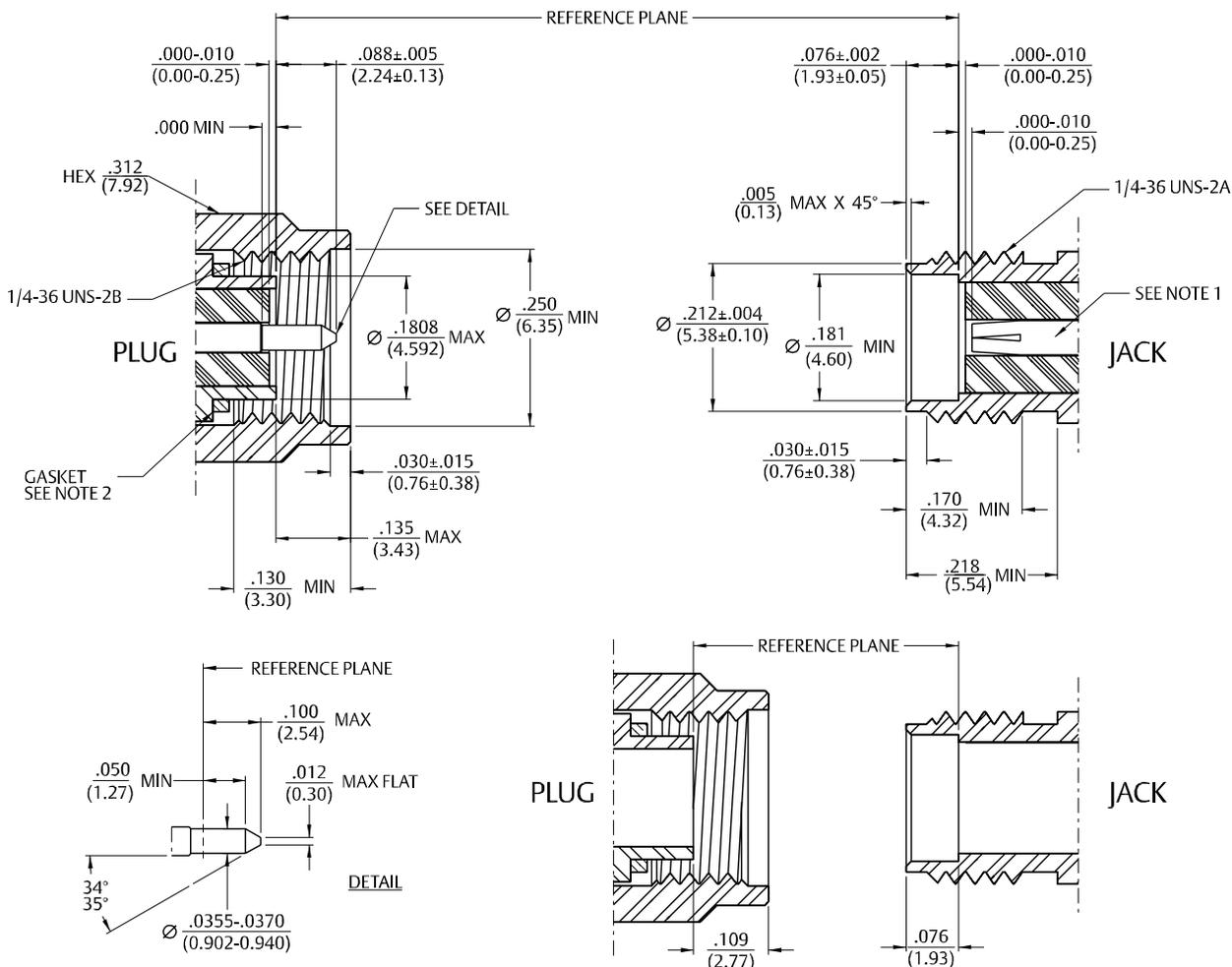

Semi-Rigid Cable

Straight Solder Type Plug – with Contact, Captive Nut Thin Wall Connector Interface



Cable Type	Gold Plated	Nickel Plated	Fig.	"A"
RG-405	142-0693-001	142-0693-006	1	.405 (10.29)
RG-402	142-0694-001*	142-0694-006*	2	.440 (11.18)

Assembly instructions page 214.

*Mating torque 8 lb-in max, coupling proof torque 8 lb-in max.

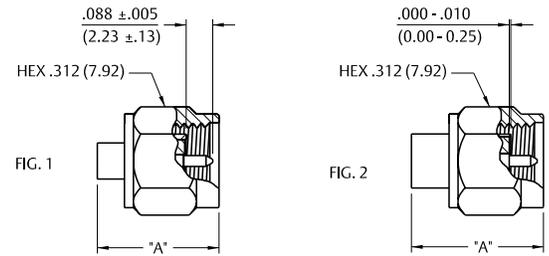

Straight Solder Type Plug – without Contact, Thread-on Nut



Cable Type	Gold Plated	Nickel Plated
RG-402	142-0694-011	142-0694-016

Assembly instructions page 214.

Center conductor of cable serves as contact.

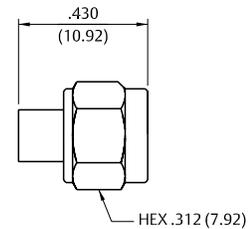

Right Angle Solder Type Plug (1-piece body)



Cable Type	Gold Plated	Nickel Plated	"A"	"B"
RG-405	142-0693-101	142-0693-106	.336 (8.53)	.253 (6.43)
RG-402	142-0694-101	142-0694-106	.462 (11.73)	.306 (7.77)

Assembly instructions page 213.

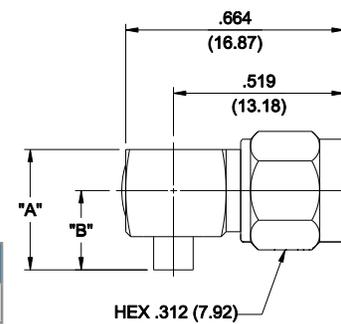

Semi-Rigid Cable

Straight Solder Type Jack

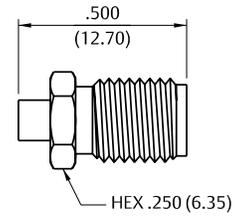

Cable Type	Gold Plated	Nickel Plated
RG-405	142-0593-001	142-0593-006
RG-402	142-0594-001	142-0594-006

Assembly instructions page 214.

Straight Solder Type Bulkhead Jack with O-Ring

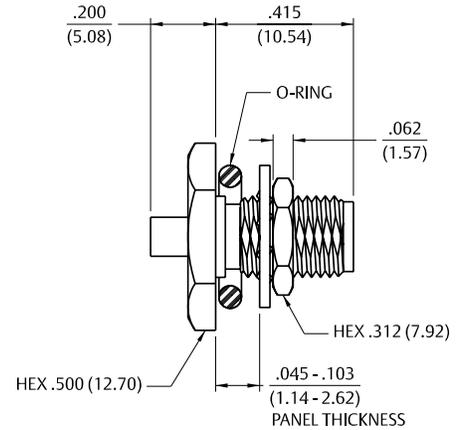

Cable Type	Gold Plated	Nickel Plated
RG-405	142-0593-401	142-0593-406
RG-402	142-0594-401	142-0594-406

Assembly instructions page 214.

Mounting hole layout figure 1 page 194.

Straight Solder Type Bulkhead Jack

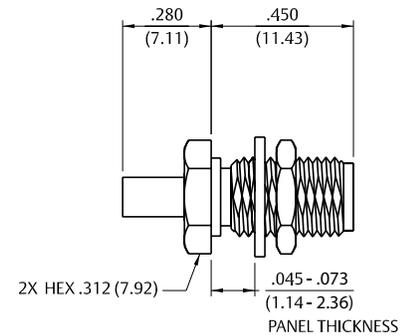

Cable Type	Gold Plated
RG-405	142-0593-411

Assembly instructions page 214.

Mounting hole layout figure 1 page 194.

Flexible Cable

Straight Crimp Type Bulkhead Jack – Captivated Contact



Cable Type	Gold Plated	Nickel Plated
RG-178, 196	142-0302-401	142-0302-406
RG-161, 174, 188, 316	142-0303-401	142-0303-406
RG-188 DS, RG-316 DS	142-0304-401	142-0304-406
RG-58, 141, 303	142-0307-401	142-0307-406
RG-55, 142, 223, 400	142-0308-401	142-0308-406

Assembly instructions page 225.
Mounting hole layout figure 1 page 194.

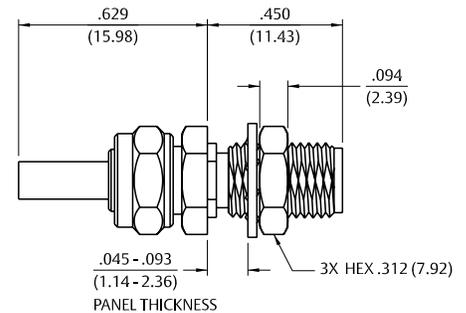

Straight Crimp Type Bulkhead Jack (3-piece) – Solder or Crimp Captivated Contact



Cable Type	Gold Plated	Nickel Plated	"A"
RG-178, 196	142-0302-431	142-0302-436	.285 (7.24)
RG-161, RG-16, 174, 188, 316, LMR-100 HPF-100 RF-100	142-0303-411	142-0303-416	.385 (9.78)
RG-188 DS, RG-316 DS	142-0304-411	142-0304-416	.385 (9.78)
RG-58, 141, 303, LMR-195, HPF-195, RF-195	142-0307-411	142-0307-416	.385 (9.78)
RG-55, 142, 223, 400	142-0308-411	142-0308-416	.385 (9.78)
RG-179, 187	142-0333-411	142-0333-416	.385 (9.78)
LMR-200, HPF-200, RF-200	142-0339-401	142-0339-406	.545 (13.84)
LMR-240, HPF-240, RF-240	142-0335-401	142-0335-406	.545 (13.84)

Assembly Instructions: RG-178 page 217. LMR 195, 200 and 240, see page 220.
Other cable groups, see page 219. Mounting hole layout figure 1 page 194.

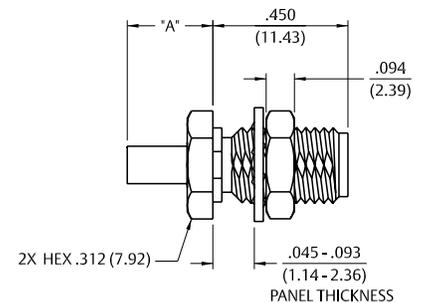

Straight Crimp Type Jack (3-piece) – Solder or Crimp Captivated Contact



Cable Type	Gold Plated	Nickel Plated	"A"
RG-178, 196	142-0302-011	142-0302-016	.651 (16.54)
RG-161, 174, 188, 316	142-0303-011	142-0303-016	.756 (19.20)
RG-188 DS, RG-316 DS	142-0304-011	142-0304-016	.756 (19.20)
RG-58, 141, 303	142-0307-011	142-0307-016	.756 (19.20)
RG-55, 142, 223, 400	142-0308-011	142-0308-016	.756 (19.20)

Assembly Instructions: RG-178 page 217. LMR 195, 200 and 240, see page 220.
Other cable groups, see page 219. Mounting hole layout figure 1 page 194.

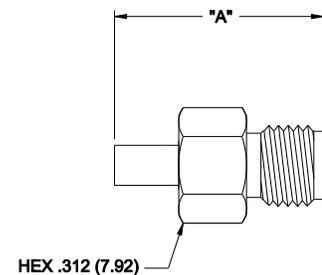

PC Mount

Straight Plug Receptacle



Gold Plated	Nickel Plated
142-0801-201	142-0801-206

Mounting hole layout figure 2 page 194.

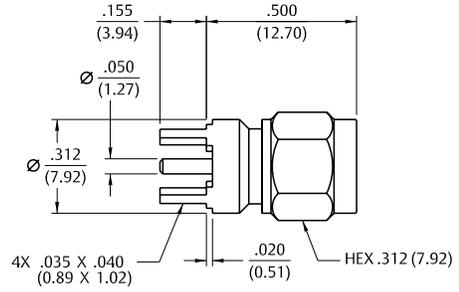

Right Angle Plug Receptacle



Gold Plated	Nickel Plated
142-0801-301	142-0801-306

Mounting hole layout figure 2 page 194.

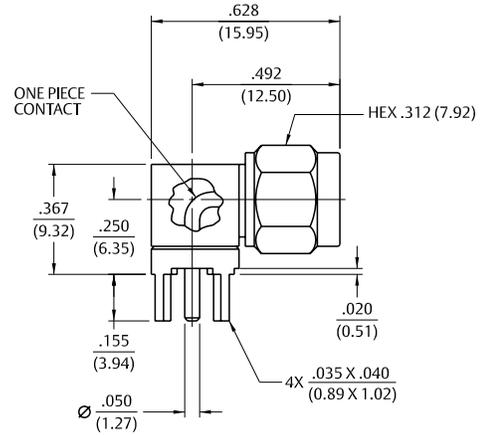

Straight Jack Receptacle



Gold Plated	Nickel Plated	"A"
142-0701-201	142-0701-206	.155 (3.94)
142-0701-231	142-0701-236	.110 (2.79)

Mounting hole layout figure 2 page 194.

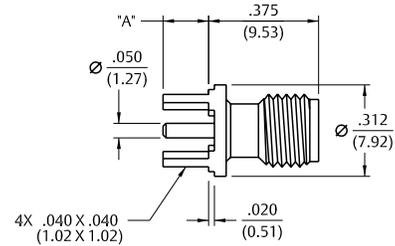

Straight Bulkhead Jack Receptacle



Gold Plated	Nickel Plated	"A"	"B"
142-0701-421	142-0701-426	.700 (17.78)	.450 (11.43)
142-0701-491	142-0701-496	.065 (1.65)	.755 (19.18)

Mounting hole layout figure 2 page 194.

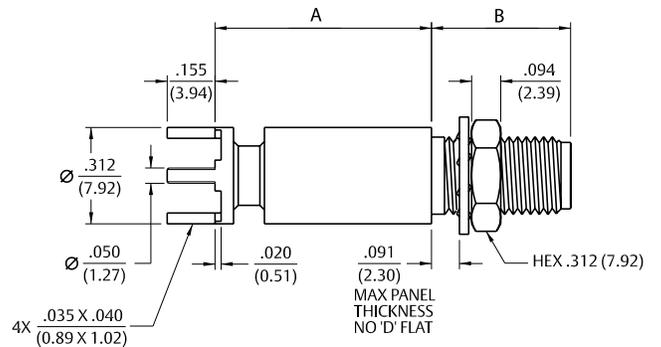

PC Mount

The **End Launch** connector is attached to the circuit board by inserting the board edge between the legs and soldering the legs and center conductor to pads on the board. For optimum high frequency performance, the connector to circuit board transition must be adjusted for low VSWR. To compensate for the transition from coax to microstrip, trace widths “A” and “B” must be adjusted based on circuit board thickness. When properly adjusted, this technique yields a low VSWR over a wide bandwidth.

The tabulated dimensions “A”, “B”, “C”, “D”, and “E” were determined experimentally to achieve low VSWR (typically less than 1.5 up to 18 GHz). The circuit board used connectors for these tests was double-sided FR 4 with 1 oz. copper on both sides. The copper was left on the bottom of the board to create a ground plane for the 50 Ohm microstrip structure. While not all inclusive, these dimensions are given as reference information for selected SMA End Launch connectors. Further adjustments may be necessary depending upon the application. All dimensions are in inches.

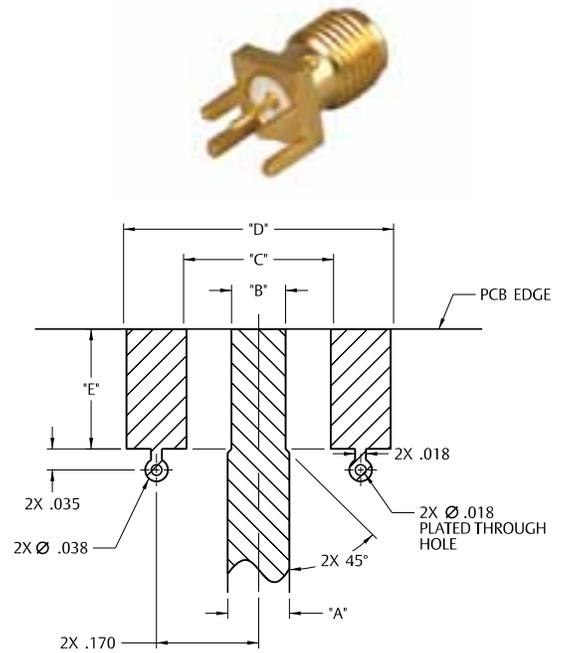

Part No.	Base Width	Board Thickness	“A”	“B”	“C”	“D”	“E”
142-0701-801/806	.375	.062	.103	.090	.250	.440	.200
142-0701-851/858	.375	.062	.103	.090	.250	.440	.200
142-0701-871/876	.375	.062	.103	.090	.250	.440	.200
142-0711-821/826	.250	.062	.103	.070	.170	.380	.165
142-0711-871/876	.375	.047	.083	.075	.250	.440	.200
142-0711-881/886	.375	.047	.083	.075	.250	.440	.200
142-0701-881/886	.375	.031	.050	.045	.250	.440	.200

Tabulated Dimensions “A”, “B”, “C”, and “D” are symmetrical about the center line.

PC Mount

End Launch Jack Receptacle – Round Contact

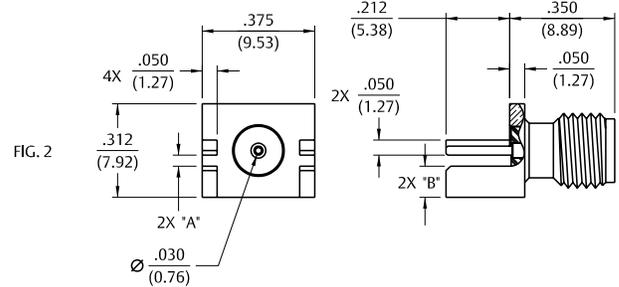
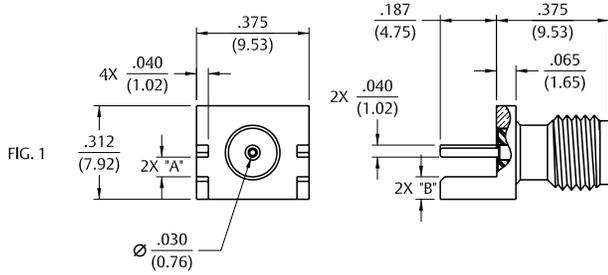

Gold Plated	Nickel Plated	Board Thickness	"A"	"B"	Figure
142-0701-801	142-0701-806	.062 (1.57)	.068 (1.73)	.073 (1.85)	1
142-0701-831	142-0701-836	.042 (1.07)	.048 (1.22)	.093 (2.36)	1
142-0701-881	142-0701-886	.031 (0.79)	.037 (0.94)	.104 (2.64)	2
142-0711-871	142-0711-876	.047 (1.19)	.053 (1.35)	.088 (2.24)	1

End Launch Jack Receptacle – Tab Contact

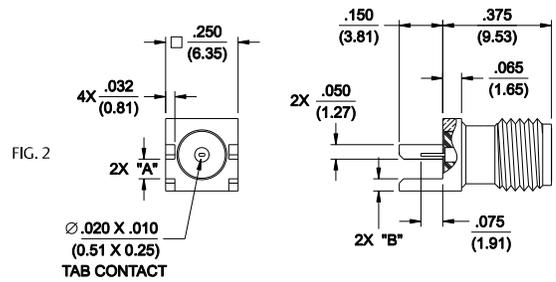
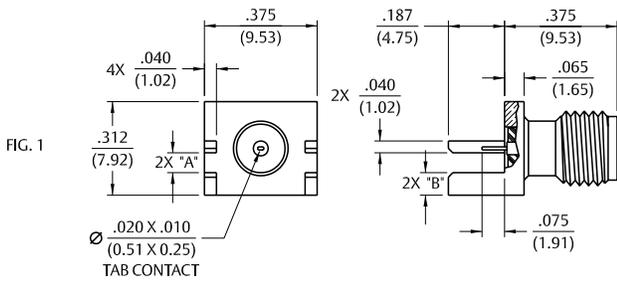

Gold Plated	Nickel Plated	Board Thickness	"A"	"B"	Figure
142-0701-851	142-0701-856	.062 (1.57)	.068 (1.73)	.083 (2.11)	1
142-0701-841	142-0701-846	.042 (1.07)	.048 (1.22)	.103 (2.62)	1
142-0711-881	142-0711-886	.047 (1.19)	.053 (1.35)	.098 (2.24)	1
142-0721-811	142-0721-816	.025 (0.64)	.030 (0.76)	.121 (3.07)	1
142-0721-861	142-0721-866	.032 (0.81)	.037 (0.94)	.083 (2.11)	2

Bulkhead Mount

End Launch Jack Receptacle – Surface Mount



Gold Plated	Packaging
142-0721-881	Stock
142-0721-882	Tape and Reel 475 pcs/reel

Recommended land pattern figure 22 page 195.

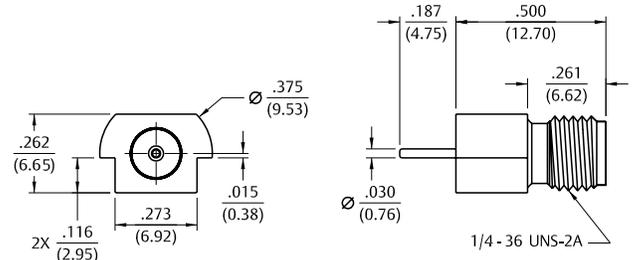

Front Mount Bulkhead Jack Receptacle



Gold Plated	Nickel Plated
142-0701-411	142-0701-416

Mounting hole layout figure 1 page 194.

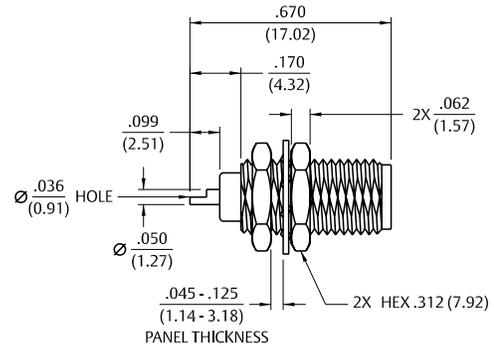

Rear Mount Bulkhead Jack Receptacle



Gold Plated	Nickel Plated
142-0701-401	142-0701-406

Mounting hole layout figure 1 page 194.

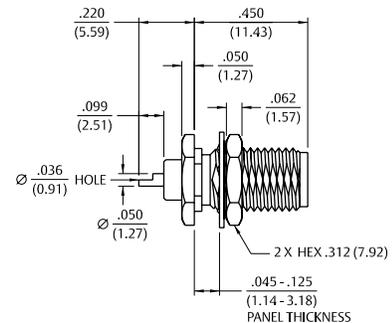

Right Angle Bulkhead Mount Jack Receptacle



Gold Plated	Nickel Plated
142-0701-531	142-0701-536

Mounting hole layout figure 1 page 194.

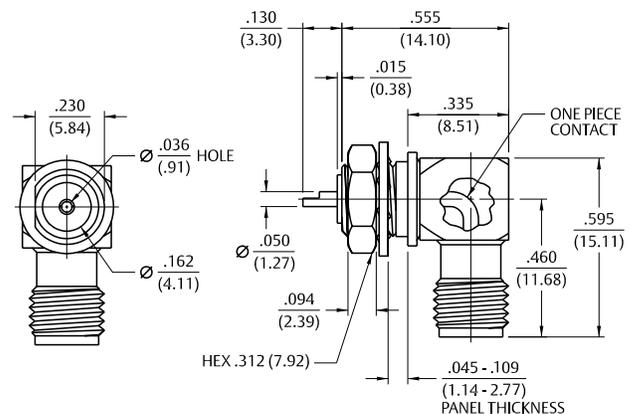

Spark Plugs

Jack Receptacle – Thread Mount Field Replaceable



Gold Plated	Nickel Plated	Accepts Pin Size
142-1731-001	142-1731-006	.020 (0.51)
142-1731-011	142-1731-016	.036 (0.91)

Mounting hole layout figure 19 page 195.

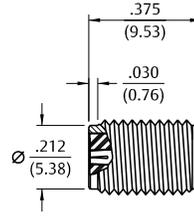

Jack Receptacle – Thread Mount Extended Dielectric (Non-Hermetic)



Gold Plated	Nickel Plated
142-1731-021	142-1731-026

Mounting hole layout for 142-1731-021 figure 19 page 195.

Mounting hole layout for 142-1731-026 figure 18 page 195.

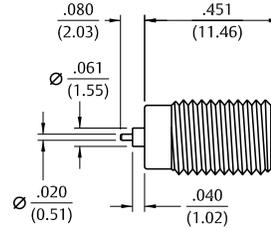

Jack Receptacle – Thread Mount with Hardware Extended Dielectric Bulkhead



Gold Plated	Nickel Plated
142-1731-031	142-1731-036

Mounting hole layout for 142-1731-031 figure 18 page 195.

Mounting hole layout for 142-1731-036 figure 1 page 194.

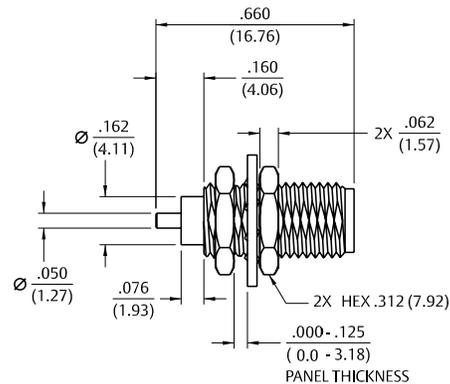

Spark Plugs

Jack Receptacle – Knurl Mount * Round Contact



Gold Plated	Nickel Plated	"A"	"B"
142-1721-011	142-1721-016	.030 (0.76)	.187 (3.18)
142-1721-021	142-1721-026	.050 (1.24)	.190 (4.83)

* Not intended for use in materials harder than Rockwell B82.
Mounting hole layout figure 17 page 195.

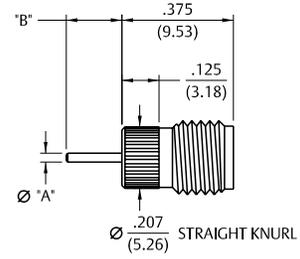

Jack Receptacle – Knurl Mount * Solder Cup Contact



Gold Plated	Nickel Plated
142-0701-481	142-0701-486

* Not intended for use in materials harder than Rockwell B82.
Mounting hole layout figure 17 page 195.

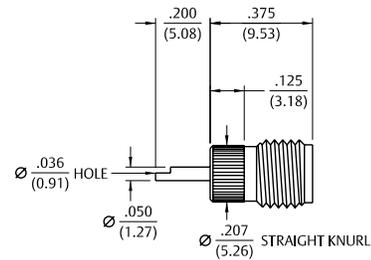

Jack Receptacle – Knurl Mount * Extended Dielectric



Gold Plated	Nickel Plated	"A"	"B"
142-1721-031	142-1721-036	.190 (4.83)	.095 (2.41)
142-1721-041	142-1721-046	.240 (6.10)	.180 (4.57)
142-1721-051	142-1721-056	.705 (17.91)	.590 (14.99)

* Not intended for use in materials harder than Rockwell B82.
Mounting hole layout figure 17 page 195.

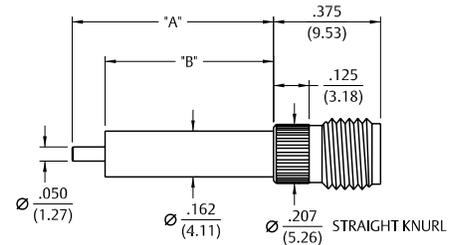

Panel Mount

4-Hole Flange Mount Jack Receptacle – Extended Dielectric

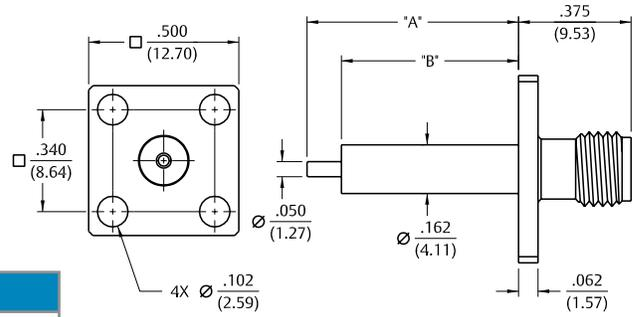

Gold Plated	Nickel Plated	"A"	"B"
142-1701-121	142-1701-126	.705 (17.91)	.590 (14.99)
142-1701-041	142-1701-046	.190 (4.83)	.095 (2.41)

4-Hole Flange Mount Jack Receptacle – Extended Dielectric

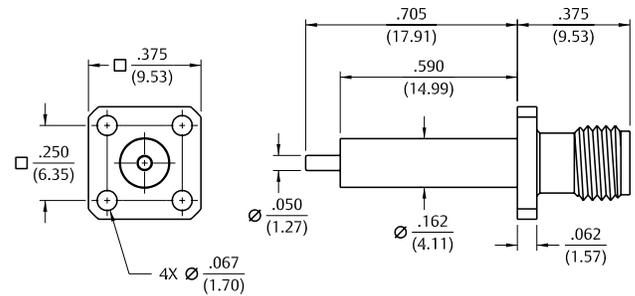

Gold Plated	Nickel Plated
142-1701-011	142-1701-016

2-Hole Flange Mount Jack Receptacle – Extended Dielectric

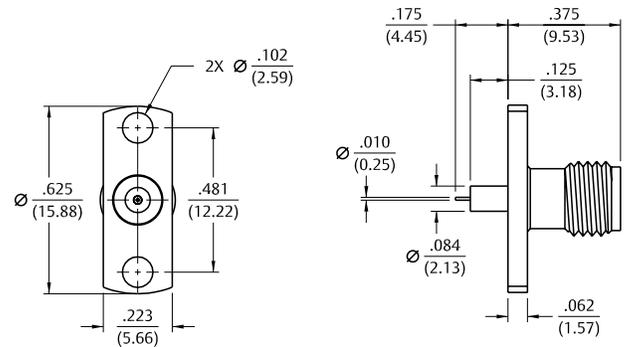

Gold Plated	Nickel Plated
142-1701-201	142-1701-206

Panel Mount

2-Hole Right Angle Flange Mount Jack Receptacle – Extended Dielectric 90° Orientation

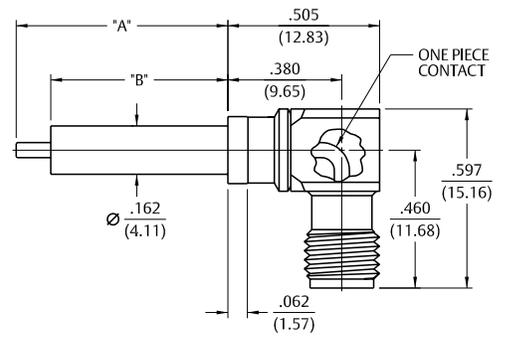
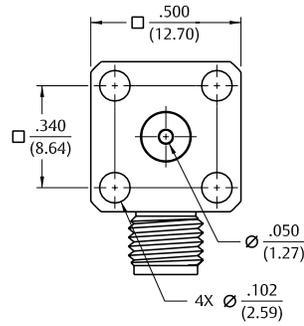

Gold Plated	Nickel Plated	"A"	"B"
142-1711-011	142-1711-016	.705 (17.91)	.590 (14.99)
142-1711-061	142-1711-066	.195 (4.95)	.130 (3.30)

2-Hole Right Angle Flange Mount Jack Receptacle – Extended Dielectric +45° Orientation

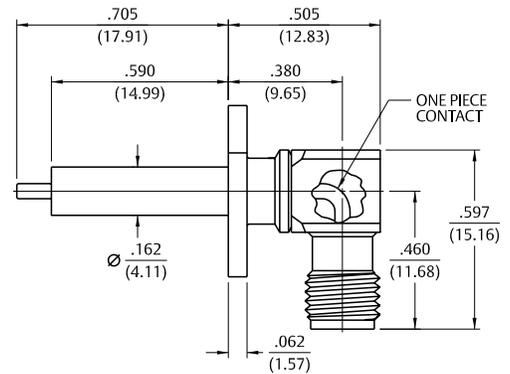
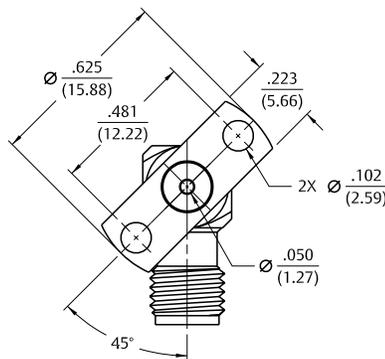

Gold Plated	Nickel Plated
142-1711-021	142-1711-026

2-Hole Right Angle Flange Mount Jack Receptacle – Extended Dielectric -45° Orientation

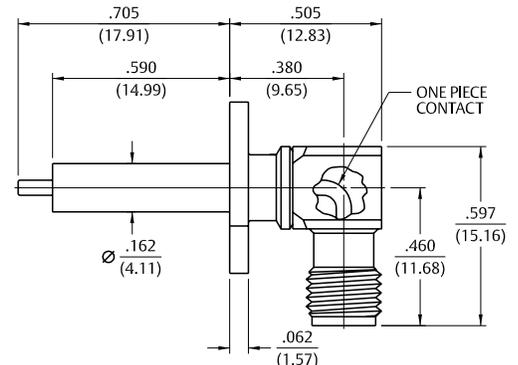
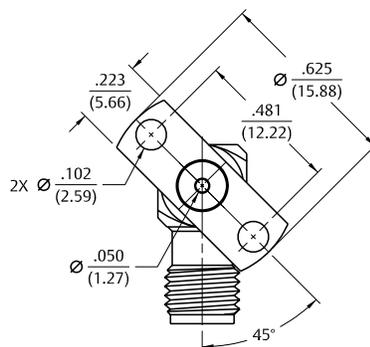

Gold Plated	Nickel Plated
142-1711-031	142-1711-036

Field Replaceable Panel Mount

2-Hole Flange Mount Jack Receptacle – with EMI Gasket



Accepts Pin Size	Gold Plated	Nickel Plated
.012 (0.30)	142-1701-601	142-1701-606
.015 (0.38)	142-1701-611	142-1701-616
.018 (0.46)	142-1701-621	142-1701-626

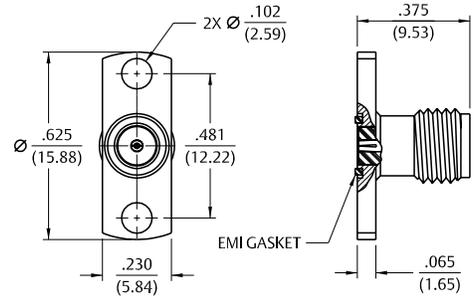

2-Hole Flange Mount Jack Receptacle – without EMI Gasket



Accepts Pin Size	Gold Plated	Nickel Plated
.020 (0.51)	142-1701-631	142-1701-636
.036 (0.91)	142-1701-641	142-1701-646

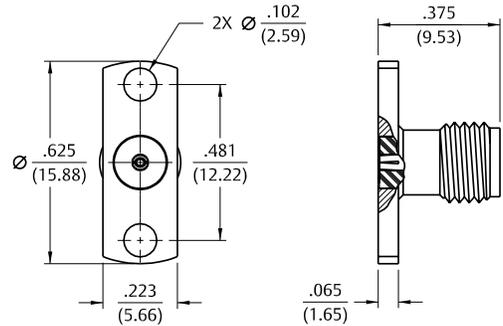

4-Hole Flange Mount Jack Receptacle – with EMI Gasket



Accepts Pin Size	Gold Plated	Nickel Plated
.012 (0.30)	142-1701-501	142-1701-506
.015 (0.38)	142-1701-511	142-1701-516
.018 (0.46)	142-1701-521	142-1701-526

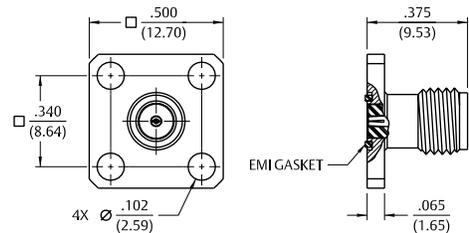

Field Replaceable Panel Mount

4-Hole Right Angle Flange Mount Jack Receptacle – with EMI Gasket

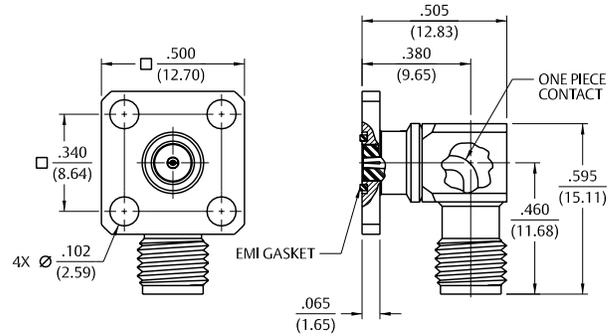

Accepts Pin Size	Gold Plated	Nickel Plated
.015 (0.38)	142-1711-511	142-1711-516
.018 (0.46)	142-1711-521	142-1711-526

2-Hole Flange Mount Plug Receptacle – with EMI Gasket

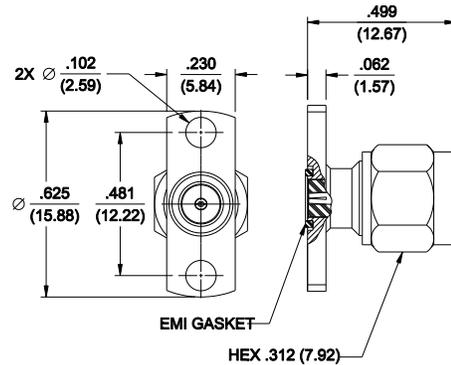

Accepts Pin Size	Gold Plated	Nickel Plated
.012 (0.30)	142-1801-601	142-1801-606
.015 (0.38)	142-1801-611	142-1801-616
.018 (0.46)	142-1801-621	142-1801-626

4-Hole Flange Mount Plug Receptacle – with EMI Gasket

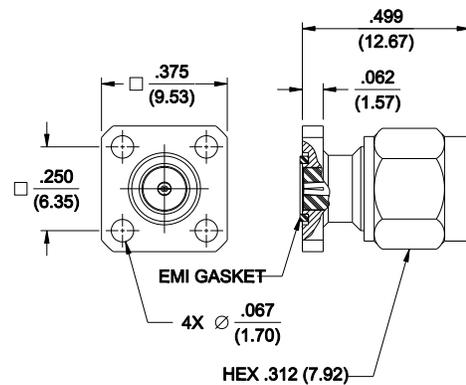

Accepts Pin Size	Gold Plated	Nickel Plated
.012 (0.30)	142-1801-551	142-1801-556
.015 (0.38)	142-1801-561	142-1801-566
.018 (0.46)	142-1801-571	142-1801-576

In-Series Adapters

Jack to Jack Adapter

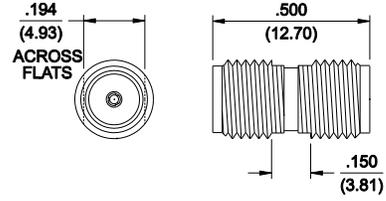

Gold Plated	Nickel Plated
142-0901-801	142-0901-806

Jack to Bulkhead Jack Adapter

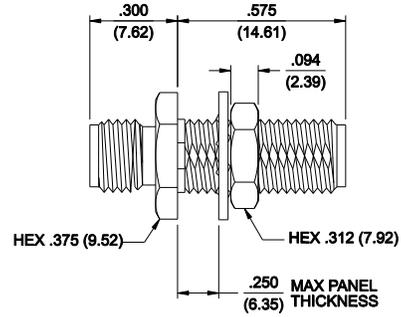

Gold Plated	Nickel Plated
142-0901-401	142-0901-406

Plug to Plug Adapter

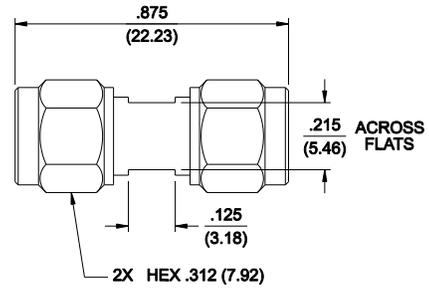

Gold Plated	Nickel Plated
142-0901-811	142-0901-816

Plug to Jack Adapter

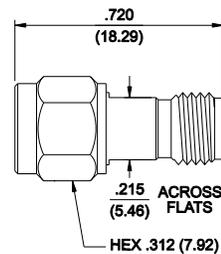

Gold Plated	Nickel Plated
142-0901-821	142-0901-826

Specifications

Electrical Specifications

Impedance: 50 Ohms

Frequency Range:

Flexible cable connectors 0-12.4 GHz

Flexible cable connectors 0-18.0 GHz

VSWR: (max) (f = GHz)

	Straight Cabled Connectors	Right Angle Cabled Connectors
RG-316, LMR-100 cable	1.15 + .02f	1.15 + .03f
RG-58, LMR-195 cable	1.17 + .025f	1.17 + .06f
RG-142 cable	1.17 + .02f	1.15 + .03f
LMR-200, LMR-240 cable	1.10 + .03f	1.10 + .06f
Uncabled receptacles.....	N/A	

Working Voltage: (VRMS max)

	Sea Level	70K Feet
RG-316, LMR-100, 195, 200	250	65
RG-58, RG-142, LMR-240, uncabled receptacles.....	335	85

Dielectric Withstanding Voltage: (VRMS min at sea level)

RG-316; LMR-100, 195, 200	750
RG-58, RG-142, LMR-240, uncabled receptacles.....	1000

Insulation Resistance: 5000 megohms min

Contact Resistance: (milliohms max)

	Initial	After Environmental
Center contact (straight cabled connectors and uncabled receptacles)	3.0	4.0
Center contact (right angle cabled connectors)	4.0	6.0
Outer contact (all connectors).....	2.0	N/A
Braid to body (gold plated connectors)	0.5	N/A
Braid to body (nickel plated connectors)	5.0	N/A

Corona Level: (Volts min at 70,000 feet)

RG-316, LMR-100, 195, 200	190
RG-58, RG-142, LMR-240, uncabled receptacles	250

Insertion Loss: (dB max)

Straight flexible cable connectors	$0.06\sqrt{f \text{ (GHz)}}$, tested at 6 GHz
Right angle flexible cable connectors	$0.15\sqrt{f \text{ (GHz)}}$, tested at 6 GHz
Low loss flexible straight cable connectors.....	$0.06\sqrt{f \text{ (GHz)}}$, tested at 1 GHz
Low loss flexible right angle cable connectors.....	$0.15\sqrt{f \text{ (GHz)}}$, tested at 1 GHz
Uncabled receptacles, field replaceable	N/A

RF Leakage: (dB min, tested at 2.5 GHz)

Flexible cable connectors	-60 dB
Uncabled receptacles and adapters	N/A

RF High Potential Withstanding Voltage:

(VRMS min tested at 4 and 7 MHz)† RG-316; LMR-100, 195, 200.....	500
RG-58, RG-142, LMR-240, uncabled receptacles.....	670

† Avoid user injury due to misapplication. See safety advisory definitions.

Mechanical Ratings

Engagement Design:

Reverse Polarity, Series SMA

Engagement/Disengagement Force:

2 lb-in max max

Mating Torque:

7 to 10 lb-in

Bulkhead Mounting Nut Torque:

15 lb-in

Coupling Proof Torque:

15 lb-in min

Coupling Nut Retention:

60 lbs min

Contact Retention:

6 lbs min axial force (captivated contacts)

4 oz-in min 4 oz-in min

Cable Retention:

	Axial Force* (lbs)	Torque (oz-in)
Connectors for RG-316, LMR-100	20	N/A
Connectors for LMR195, 200	30	N/A
Connectors for RG-58, LMR-240	40	N/A
Connectors for RG-142	45	N/A

*Or cable breaking strength whichever is less.

Durability: 500 cycles minimum

Flexible Cable

Straight Crimp Type Plug – Solder or Crimp Captivated Contact



Cable Type	Gold Plated	Nickel Plated	"A"
RG-316/U, 188, 174, 161, LMR-100 HPF-100, RF-100	142-4403-001	142-4403-006	.706 (17.93)
RG-316 DS, 188 DS	142-4404-001	142-4404-006	.706 (17.93)
RG-58, 141, 303 LMR-195, HPF-195, RF-195	142-4407-001	142-4407-006	.706 (17.93)
RG-142, 55, 223, 400	142-4408-001	142-4408-006	.706 (17.93)
LMR-200, HPF-200, RF-200	142-4439-001	142-4439-006	.844 (21.44)
LMR-240, HPF-240, RF-240	142-4435-001	142-4435-006	.844 (21.44)

Assembly Instructions: LMR 195, 200 and 240 page 219. All other cables page 220.

Right Angle Crimp Type Plug – Captivated Contact

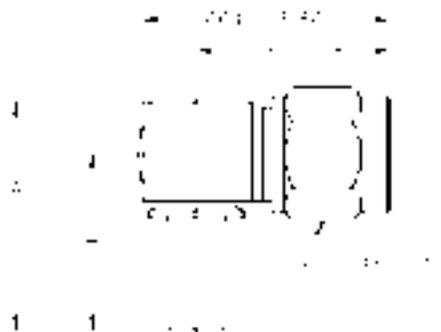

Cable Type	Gold Plated	Nickel Plated	"A"	"B"
RG-316, 188, 174, 161, LMR-100, HPF-100, RF-100	142-4403-101	142-4403-106	.611 (15.52)	.470 (11.94)
RG-316 DS, 188 DS	142-4404-101	142-4404-106	.611 (15.52)	.470 (11.94)
RG-58, 141, 303, LMR-195, HPF-195, RF-195	142-4407-101	142-4407-106	.611 (15.52)	.470 (11.94)
RG-142, 55, 223, 400	142-4408-101	142-4408-106	.611 (15.52)	.470 (11.94)
LMR-200, HPF-200, RF-200	142-4439-101	142-4439-106	.611 (15.52)	.470 (11.94)
LMR-240, HPF-240, RF-240	142-4435-101	142-4435-106	.635 (16.13)	.490 (12.45)

Assembly Instructions: LMR 195, 200 and 240 page 224. All other cables page 229.
Center conductor of cable serves as contact.

Straight Crimp Type Bulkhead Jack – Captivated Contact

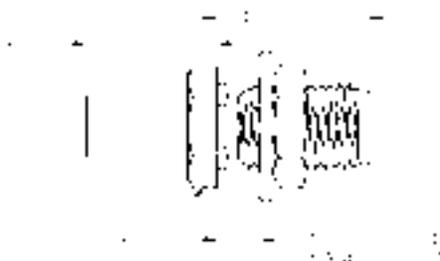

Cable Type	Gold Plated	Nickel Plated
RG-316, 188, 174, 161	142-4303-401	142-4303-406
RG-316 DS, 188 DS	142-4304-401	142-4304-406
RG-58, 141, 303	142-4307-401	142-4307-406
RG-142, 55, 223, 400	142-4308-401	142-4308-406

Assembly instructions page 219.
Mounting hole layout figure 1 page 194.

Specifications

Electrical Specifications

Impedance: 50 Ohms

Frequency Range:

Flexible cable connectors	0-12.4 GHz
Uncabled receptacles	0-18.0 GHz

VSWR: (max) (f = GHz)

	Straight Cabled Connectors	Right Angle Cabled Connectors
RG-316, LMR-100 cable	1.15 + .02f	1.15 + .03f
RG-58, LMR-195 cable	1.15 + .01f	1.15 + .02f
RG-142 cable	1.15 + .01f	1.15 + .02f
LMR-200, LMR-240 cable	1.10 + .03f	1.10 + .06f
Uncabled receptacles.....	N/A	

Working Voltage: (VRMS max)

	Sea Level	70K Feet
RG-316; LMR-100, 195, 200	250	65
RG-58, RG-142, LMR-240, uncabled receptacles.....	335	85

Dielectric Withstanding Voltage: (VRMS min at sea level)

RG-316; LMR-100, 195, 200	750
RG-58, RG-142, LMR-240, uncabled receptacles.....	1000

Insulation Resistance: 5000 megohms min

Contact Resistance: (milliohms max)

	Initial	After Environmental
Center contact (straight cabled connectors and uncabled receptacles)	3.0	4.0
Center contact (right angle cabled connectors)	4.0	6.0
Outer contact (all connectors).....	2.0	N/A
Braid to body (gold plated connectors)	0.5	N/A
Braid to body (nickel plated connectors)	5.0	N/A

Corona Level: (Volts min at 70,000 feet)†

RG-316, LMR-100, 195, 200	190
RG-58, RG-142, LMR-240, uncabled receptacles	250

Insertion Loss: (dB max)

Straight flexible cable connectors	$0.06\sqrt{f}$ (GHz), tested at 6 GHz
Right angle flexible cable connectors	$0.15\sqrt{f}$ (GHz), tested at 6 GHz
Low loss flexible straight cable connectors	$0.06\sqrt{f}$ (GHz), tested at 1 GHz
Low loss flexible right angle cable connectors.....	$0.15\sqrt{f}$ (GHz), tested at 1 GHz
Uncabled receptacles, field replaceable	N/A

RF Leakage: (dB min tested at 2.5 GHz)

† Avoid user injury due to misapplication. See safety advisory definitions.

Mechanical Ratings

Engagement Design: Reverse Thread, Series SMA

Engagement/Disengagement Force: 2 lb-in max

Mating Torque: 7 to 10 lb-in

Bulkhead Mounting Nut Torque: 15 lb-in

Coupling Proof Torque: 15 lb-in min

Coupling Nut Retention: 60 lbs min

Contact Retention: 6 lbs. min axial force (captivated contacts)

4 oz-in min torque (uncabled receptacles)

Cable Retention:

	Axial Force* (lbs)	Torque (oz-in)
RG-316, LMR-100.....	20	N/A
LMR195, 200.....	30	N/A
RG-58, LMR-240.....	40	N/A
RG-142.....	45	N/A

*Or cable breaking strength whichever is less.

Durability: 500 cycles min

Flexible Cable

Straight Crimp Type Plug – Solder or Crimp Captivated Contact

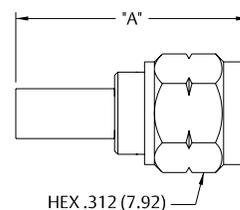

Cable Type	Gold Plated	Nickel Plated	"A"
RG-316, 188, 174, 161, LMR-100 HPF-100 RF-100	142-5403-001	142-5403-006	.706 (17.93)
RG-316 DS, 188 DS,	142-5404-001	142-5404-006	.706 (17.93)
RG-58, 141, 303 LMR-195, HPF-195, RF-195	142-5407-001	142-5407-006	.706 (17.93)
RG-142, 55, 223, 400	142-5408-001	142-5408-006	.706 (17.93)
LMR-200, HPF-200, RF-200	142-5439-001	142-5439-006	.844 (21.44)
LMR-240, HPF-240, RF-240	142-5435-001	142-5435-006	.844 (21.44)

Assembly Instructions: LMR 195, 200 and 240 page 220. All other cables page 219.

Right Angle Crimp Type Plug – Captivated Contact

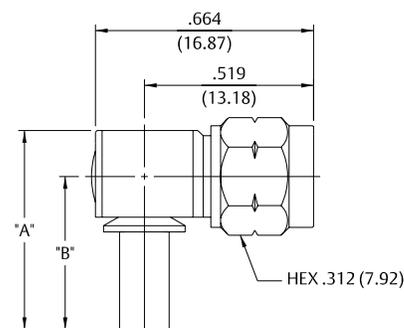

Cable Type	Gold Plated	Nickel Plated	"A"	"B"
RG-316, 188, 174, 161, LMR-100 HPF-100 RF-100	142-5403-101	142-5403-106	.611 (15.52)	.470 (11.94)
RG-316 DS 188 DS	142-5404-101	142-5404-106	.611 (15.52)	.470 (11.94)
RG-58, 141, 303, LMR-195 HPF-195 RF195	142-5407-101	142-5407-106	.611 (15.52)	.470 (11.94)
RG-142, 55, 223, 400	142-5408-101	142-5408-106	.611 (15.52)	.470 (11.94)
LMR-200 HPF-200 RF-200	142-5439-101	142-5439-106	.611 (15.52)	.470 (11.94)
LMR-240 HPF-240 RF-240	142-5435-101	142-5435-106	.635 (16.13)	.490 (12.45)

Assembly instructions: LMR 195, 200 and 240 page 229. All other cables page 224.

Straight Crimp Type Bulkhead Jack – Solder or Crimp

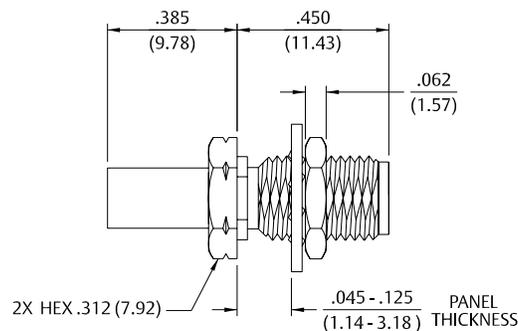

Cable Type	Gold Plated	Nickel Plated
RG-316, 188, 174, 161	142-5303-401	142-5303-406
RG-316 DS, 188 DS	142-5304-401	142-5304-406
RG-58, 141, 303	142-5307-401	142-5307-406
RG-142, 55, 223, 400	142-5308-401	142-5308-406

Assembly instructions page 219.
Mounting hole layout figure 1 page 194.

Specifications

Electrical Specifications

Impedance: 50 Ohms

Frequency Range: Flexible cable connectors 0-12.4 GHz
Uncabled receptacles 0-18.0 GHz

	Straight	
	Cabled Connectors	Right Angle Cabled Connectors
RG-316 cable	1.15 + .02f	1.15 + .03f
RG-58 cable	1.15 + .01f	1.15 + .02f
Uncabled receptacles.....	N/A	
Working Voltage: (VRMS max)†	<u>Sea Level</u>	<u>70K Feet</u>
RG-316	250	65
RG-58, uncabled receptacles	335	85

Dielectric Withstanding Voltage: (VRMS min at sea level)†

RG-316	750
RG-58, uncabled receptacles	1000

Insulation Resistance: 5000 megohms min

Contact Resistance: (milliohms max)

	<u>Initial</u>	<u>After Environmental</u>
Center contact (straight cabled connectors, uncabled receptacles).....	3.0	4.0
Center contact (right angle cabled connectors).....	4.0	6.0
Outer contact (all connectors).....	2.0	N/A
Braid to body	0.5	N/A

Corona Level: (Volts min at 70,000 feet)†

RG-316 190	250
RG-58, uncabled receptacles	250

Insertion Loss: (dB max)

Straight flexible cable connectors	$.06 \sqrt{f(\text{GHz})}$, tested at 6 GHz
Right angle flexible cable connectors	$.15 \sqrt{f(\text{GHz})}$, tested at 6 GHz
Uncabled receptacles	N/A

RF Leakage: (dB min tested at 2.5 GHz)

Flexible cable connectors	-60 dB
Uncabled receptacles	N/A

RF High Potential Withstanding Voltage: (VRMS minimum, tested at 4 and 7 MHz)†

RG-316	500
RG-58, uncabled receptacles	670

† Avoid user injury due to misapplication. See safety advisory definitions inside front cover.

Mechanical Specifications

Engagement Design: MIL-STD-348, Series SMA

Engagement/Disengagement Force: 2 lb-in min max

Mating Torque: 7 to 10 lb-in min

Coupling Proof Torque: 15 lb-in min

Coupling Nut Retention: 60 lbs min

Contact Retention: 6 lbs min axial force (captivated contacts)
4 oz-in min torque (uncabled receptacles)

Cable Retention:	<u>Axial Force*</u> (lbs)	<u>Torque (oz-in)</u>
RG-316	20	N/A
RG-58	40	N/A

*Or cable breaking strength whichever is less.

Durability: 500 cycles min

Environmental Specifications

(Meets or Exceeds the Applicable Paragraph of MIL-PRF-39012)

Temperature Range: - 65°C to + 165°C

Thermal Shock: MIL-STD-202, Method 107, Condition B

Corrosion: MIL-STD-202, Method 101, Condition B

Shock: MIL-STD-202, Method 213, Condition I

Vibration: MIL-STD-202, Method 204, Condition D

Moisture Resistance: MIL-STD-202, Method 106

Material Specifications

(See non-magnetic materials page 10)

† Avoid user injury due to misapplication. See safety advisory definitions inside front cover.

PC Mount

Straight Jack Receptacle



Gold Plated	"A"
142-9701-201	.155 (3.94)
142-9701-211	.110 (2.79)

Mounting hole layout figure 3 on page 194.

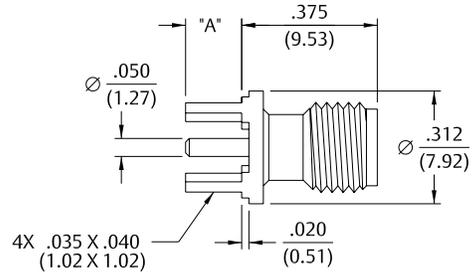

Straight Plug Receptacle



Gold Plated
142-9801-201

Mounting hole layout figure 3 on page 194.

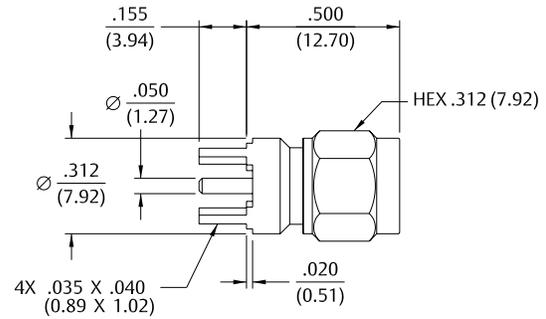

Right Angle Jack Receptacle



Gold Plated
142-9701-301

Mounting hole layout figure 3 on page 194.

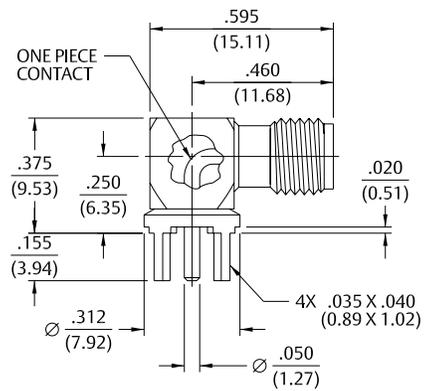

PC Mount

Jack Receptacle – Round Body

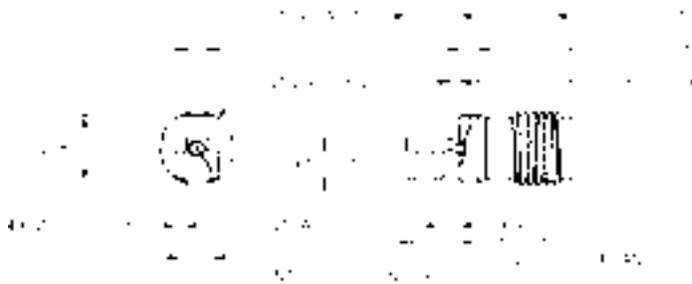

Gold Plated	High Frequency Substrate Thickness	"A"	"B"	"C"
142-0761-801	.008 (0.20) - .014 (0.36)	.010 (0.25)	.050 (1.27)	.096 (2.44)
142-0761-821	.014 (0.36) - .020 (0.51)	.015 (0.38)	.067 (1.70)	.113 (2.87)

Assembly instructions page 228.

Jack Receptacle, Square Body



Gold Plated	High Frequency Substrate Thickness	"A"	"B"	"C"
142-0761-811	.008 (0.20) - .014 (0.36)	.010 (0.25)	.050 (1.27)	.096 (2.44)
142-0761-831	.014 (0.36) - .020 (0.51)	.015 (0.38)	.067 (1.70)	.113 (2.87)

Assembly instructions page 228.

Jack Receptacle – PC Mount, Round Body with Thick Legs

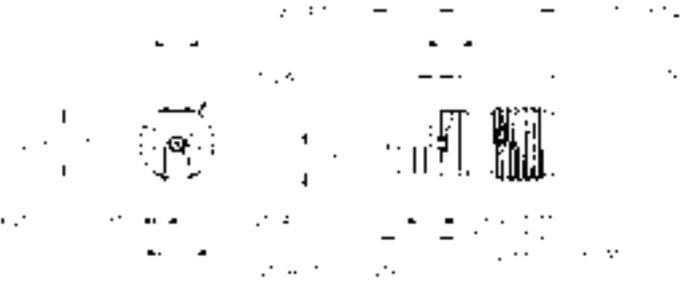

Gold Plated	High Frequency Substrate Thickness	"A"	"B"	"C"
142-0761-881	.008 (0.20) - .014 (0.36)	.010 (0.25)	.050 (1.27)	.096 (2.44)
142-0771-821	.014 (0.36) - .020 (0.51)	.015 (0.38)	.067 (1.70)	.113 (2.87)

Assembly instructions page 228.

* Coupling proof torque 8 inch pounds maximum without support wrench.

Specifications

Electrical Ratings

Impedance: 50 Ohms

Frequency Range:

Flexible cable connectors	0-12.4 GHz
Uncabled receptacles.....	0-18.0 GHz
Straight Semi-Rigid cable connectors.....	0-26.5 GHz

VSWR: (max) (f = GHz)

	Straight Cabled Connectors	Right Angle Cabled Connectors
RG-316, LMR-100 cable	1.15+.02f	1.15+.03f
RG-58, LMR-195 cable	1.15+.01f	1.15+.02f
RG-142 cable	1.15+.01f	1.15+.02f
RG-405 cable (0 - 18 GHz)	1.07+.008f	
RG-405 cable (18 - 26.5 GHz)	1.35 max	
RG-402 cable (w/contact).....	1.05+.008f	
RG-402 cable (w/o contact).....	1.035+.005f	

Insertion Loss: (dB max)

Straight flexible cable connectors	$0.06 \sqrt{f \text{ (GHz)}}$, tested at 6 GHz
Right angle flexible cable connectors	$0.15 \sqrt{f \text{ (GHz)}}$, tested at 6 GHz
Straight Semi-Rigid cable connectors with contact.....	$0.03 \sqrt{f \text{ (GHz)}}$, tested at 10 GHz
Straight Semi-Rigid cable connectors w/o contact.....	$0.03 \sqrt{f \text{ (GHz)}}$, tested at 16 GHz
Uncabled receptacles	N/A

Working Voltage: (VRMS max)

	Sea Level	70K Feet
RG-316, LMR-100, 195	250	65
RG-58, RG-142, RG-405, uncabled receptacles, RG-402 w/o contact.....	335	85
RG-402 with contact.....	500	125

Dielectric Withstanding Voltage: (VRMS min at sea level) †

	Sea Level
RG-316, LMR-100, 195	750
RG-58, RG-142, RG-405, uncabled receptacles.....	1000
RG-402 with contact.....	1500
RG-402 w/o contact.....	N/A

Corona Level: (Volts min at 70,000 feet)

	70K Feet
RG-316, LMR-100, 195	190
RG-58, RG-142, .086 Semi-Rigid, uncabled receptacles, RG-402 w/o contact.....	250
RG-402 with contact	375

Insulation Resistance: 5000 Megohms min

Contact Resistance: (milliohms max)	Initial	After Environmental
Center contact (straight cabled connectors and uncabled receptacles)	3.0*	4.0*
Center contact (right angle cabled connectors)	4.0	6.0
Outer contact (all connectors)	2.0	N/A
Braid to Body (gold plated bodies).....	0.5	N/A

*N/A where the cable center conductor is used as a contact

RF Leakage: (dB min, tested at 2.5 GHz)

Flexible cable connectors and RG-402 connectors w/o contact	-60
RG-405 connectors and RG-402 connectors with contact	-90
Uncabled receptacles	N/A

RF High Potential Withstanding Voltage: (VRMS min, tested at 4 and 7 MHz)

RG-316, LMR-100, 195	500
RG-58, RG-142, RG-405, RG-402 cable w/o contact, Uncabled receptacles	670
RG-402 with contact	1000

† Avoid user injury due to misapplication. See safety advisory definitions.

Specifications

Mating Engagement for Stainless Steel SMA Series Per MIL-STD-348A

NOTES

1. ID to meet VSWR, contact resistance and insertion/withdrawal forces when mated with a dia. .0355-.0370 pin.
2. Gasket is not supplied with brass connectors.

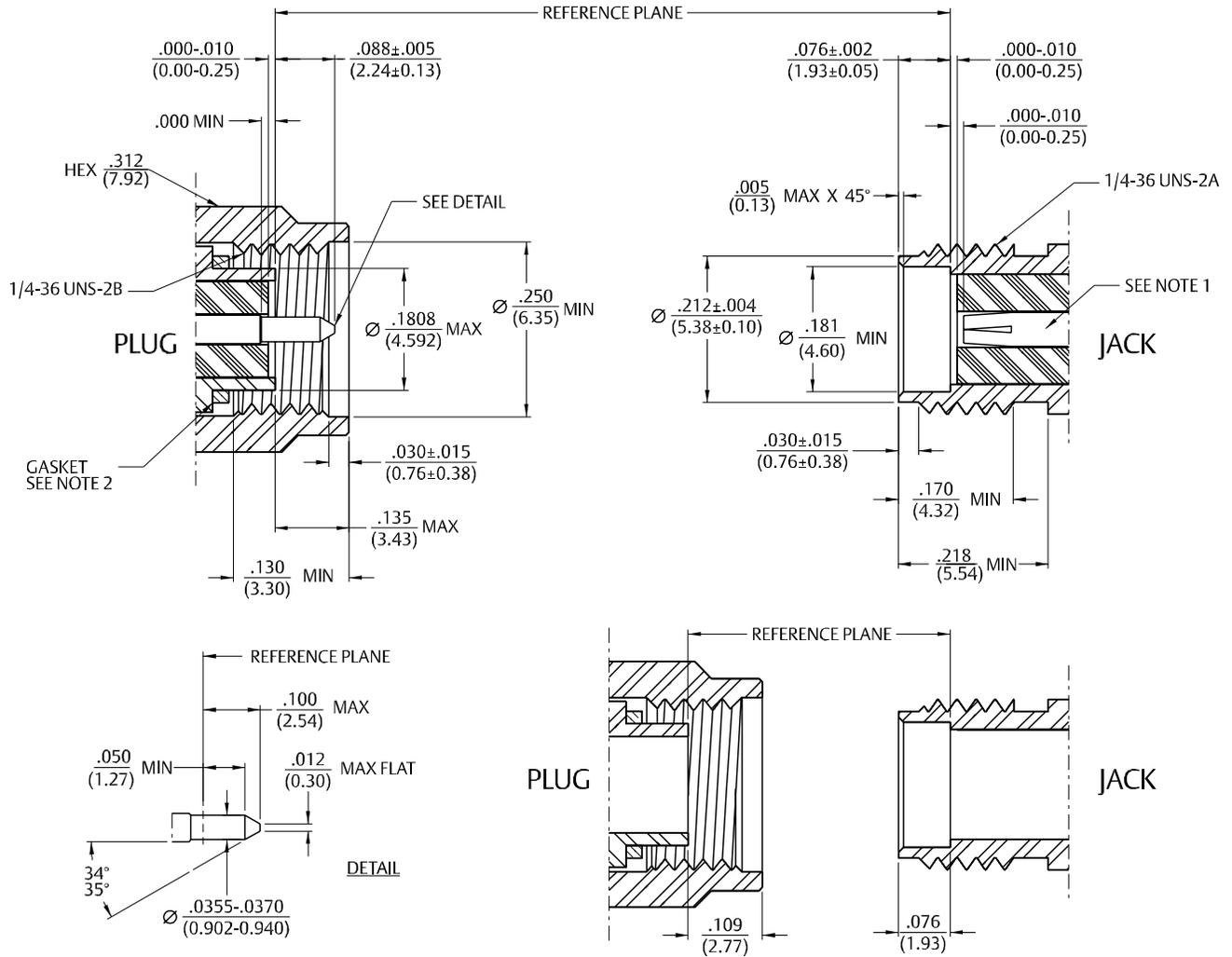

Semi-Rigid

Straight Solder Type Jack



Cable Type	Gold Plated Body
RG-405	141-0593-001
RG-402	141-0594-001

Assembly instructions page 214.

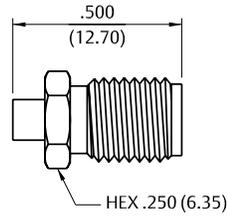

Straight Solder Type Bulkhead Jack with O-Ring



Cable Type	Gold Plated Body
RG-405	141-0593-401
RG-402	141-0594-401

Assembly instructions page 214.

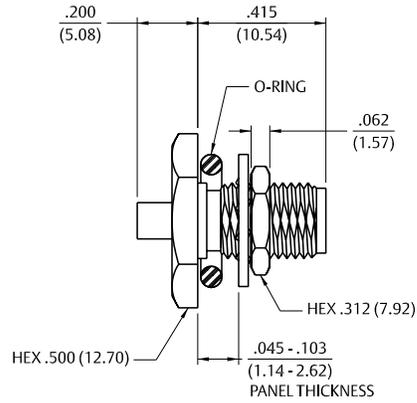

Straight Solder Type Bulkhead Jack with Captivated Solderless Contact and O-Ring



Cable Type	Gold Plated Body
RG-405	141-0593-421
RG-402	141-0594-421

Assembly instructions page 222.

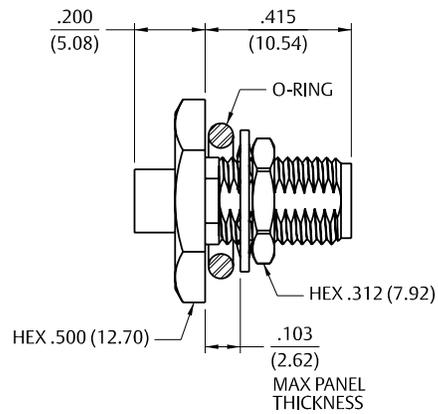

PC Mount, Bulkhead and Panel Mount

Right Angle PC Mount Jack Receptacle



Gold Plated

141-0701-301

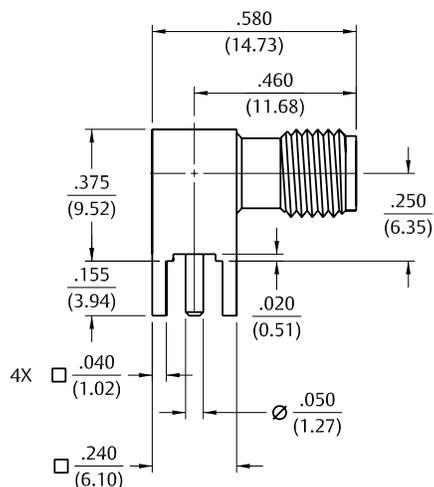

Straight PC Mount Jack Receptacle



Gold Plated

141-0701-201

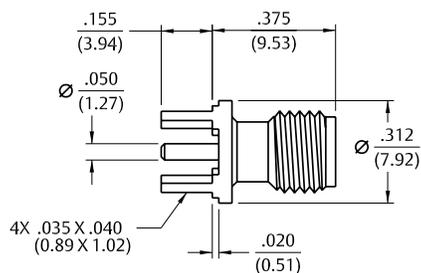

Rear Mount Bulkhead Jack Receptacle



Passivated

141-0701-402

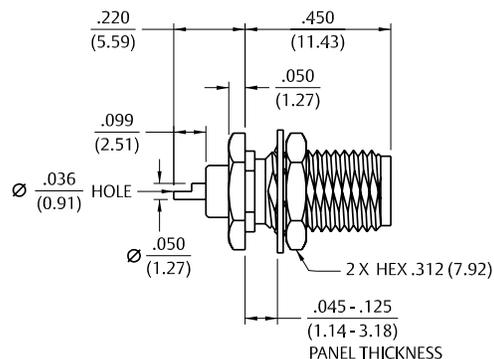

2-Hole Flange Mount Jack Receptacle – Flush Dielectric



Passivated

141-0701-602

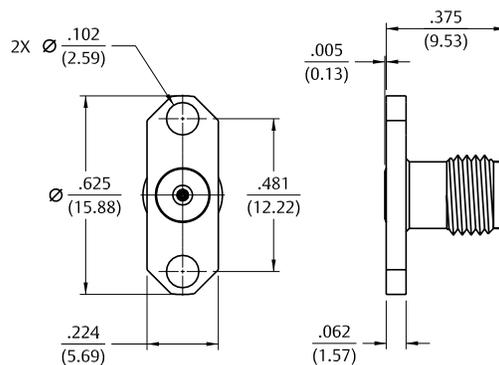

Specifications

Electrical Specifications

Impedance:	50 Ohms		
Frequency Range:	0-6 GHz		
Attenuation Values:	1, 2, 3, 6 and 10 dB Nominal*		
Attenuation Accuracy:			
dB*	0 - 4 GHz	4 - 6 GHz	
1-3	±0.3	±0.5	
4-6	±0.4	±0.5	
7-10	±0.5	±0.5	
VSWR Max:			
dB*	0 - 2.5 GHz	2.5 - 4 GHz	4 - 6 GHz
1-3	1.15 : 1	1.20 : 1	1.25 : 1
4-6	1.15 : 1	1.20 : 1	1.25 : 1
7-10	1.15 : 1	1.25 : 1	1.30 : 1
Average Input Power:	2 W Max @ +25°C		
	Derated Linearly to 0.5W at +125°C		

*Other values available, please contact Factory

Mechanical Specifications

SMA Connectors: Per MIL-STD-348A

Environmental Specifications

Temperature Range:	-55°C to +125°C
Thermal Shock:	MIL-STD-202, Method 107, Condition B except +100°C high temperature)
Shock:	MIL-STD-202, Method 213, Condition I
Vibration:	MIL-STD-202, Method 204, Condition D

Material Specifications

Connector Body:	303 Stainless Steel per ASTM A582, Passivated per MIL-F-14-72 (EL 300)
Coupling Nut:	303 Stainless Steel per ASTM A582, Passivated per MIL-F-14-72 (EL 300)
Retaining Ring:	Beryllium Copper per ASTM B196, Unplated
SMA Plug Gasket:	Silicone Rubber per ZZ-R-765
Male Contact:	Brass per ASTM B16, Gold Plated per MIL-G-45204 (.00003 min)
Female Contact:	Beryllium Copper per ASTM B196, Gold Plated per MIL-G-45204 (.00003 min)
Insulators:	PTFE per ASTM D1710
Attenuator Card:	Alumina per Mil-I-10, RoHS Compliant Terminals

SMA Fixed Attenuators Commercial Series

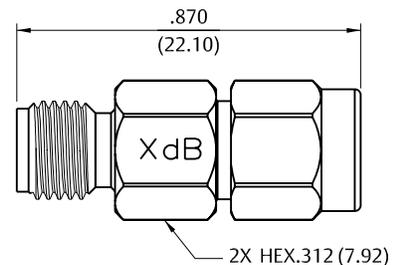

Attenuation (dB Nominal)*	Freq. Range	Stainless Steel Passivated
1	(0-6 GHz)	141-3901-801
2	(0-6 GHz)	141-3901-802
3	(0-6 GHz)	141-3901-803
6	(0-6 GHz)	141-3901-806
10	(0-6 GHz)	141-3901-810

* Standard values shown. Contact factory for other requirements. Inches (millimeters).

Specifications

Electrical Specifications

Impedance: 50 Ohms

Frequency Range:

Connectors..... 0-4 GHz

Dummy loads..... 0-1 GHz

VSWR: (max) (f = GHz)

	Straight Cabled Connectors	Right Angle Cabled Connectors
RG-178	1.30 + .04f	1.45 + .06f
RG-316, RG-58, and RG-405	1.25 + .04f	1.35 + .04f
Adapters	1.20 + .04f	

Uncabled receptacles, dummy loads N/A

Working Voltage: (VRMS max)†

Sea Level	70K Feet
.250	60
.335	85
	N/A

RG-178 250 60

RG-316, RG-58, RG-405, uncabled receptacles, adapters 335 85

Dummy loads..... N/A

Dielectric Withstanding Voltage: (VRMS min at sea level)

RG-316 750

RG-58, RG-142, uncabled receptacles 1000

Dummy loads..... N/A

Corona Level: (Volts min at 70,000 feet)†

RG-178 185

RG-316, RG-58, RG-405 250

Uncabled receptacles, adapters, dummy loads N/A

Insertion Loss: (dB max, tested at 1.5 GHz)

Straight cabled connectors 0.30 dB

Right angle cabled connectors..... 0.60 dB

Uncabled receptacles, adapters, dummy loads N/A

Insulation Resistance: 1000 megohms min

Contact Resistance: (milliohms max)

	Initial	After Environmental
Center contact (straight cabled connectors and uncabled receptacles)	6.0	8.0
Center contact (right angle cabled connectors and adapters)	12.0	16.0
Outer contact (gold plated connectors)	1.0	1.5
Outer contact (nickel plated connectors)	2.5	3.5
Braid to body (gold plated connectors)	1.0	N/A
Braid to body (nickel plated connectors)	2.5	N/A

Center contact (straight cabled connectors and uncabled receptacles)

Center contact (right angle cabled connectors and adapters)

Outer contact (gold plated connectors)

Outer contact (nickel plated connectors)

Braid to body (gold plated connectors)

Braid to body (nickel plated connectors)

RF Leakage: (dB min, tested at 2.5 GHz)

Cabled connectors -55 dB

Uncabled receptacles, adapters, dummy loads N/A

RF High Potential Withstanding Voltage:

(VRMS min, tested at 4 and 7 MHz)†

RG-178 500

RG-316, RG-58 700

Uncabled receptacles and adapters 600

Dummy loads..... N/A

Power Rating (Dummy Load): 0.5 watt @ +25°C, derated to 0.25 watt @ +125°C

Specifications

Mating Engagement for SMB Series

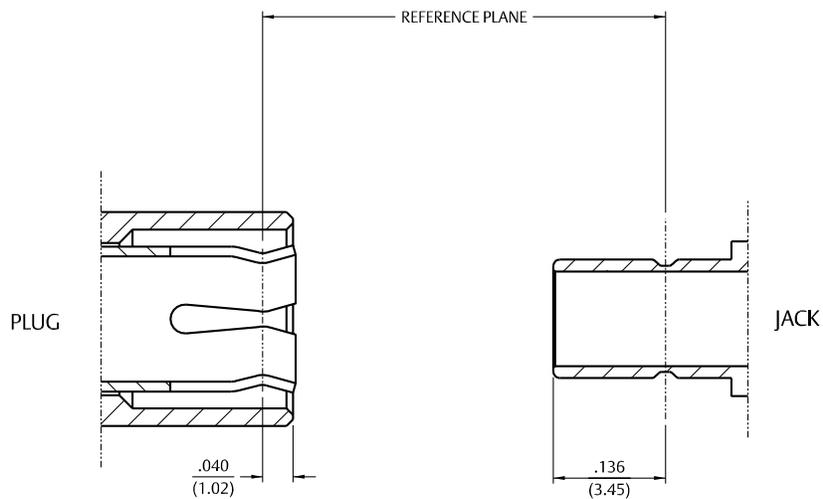
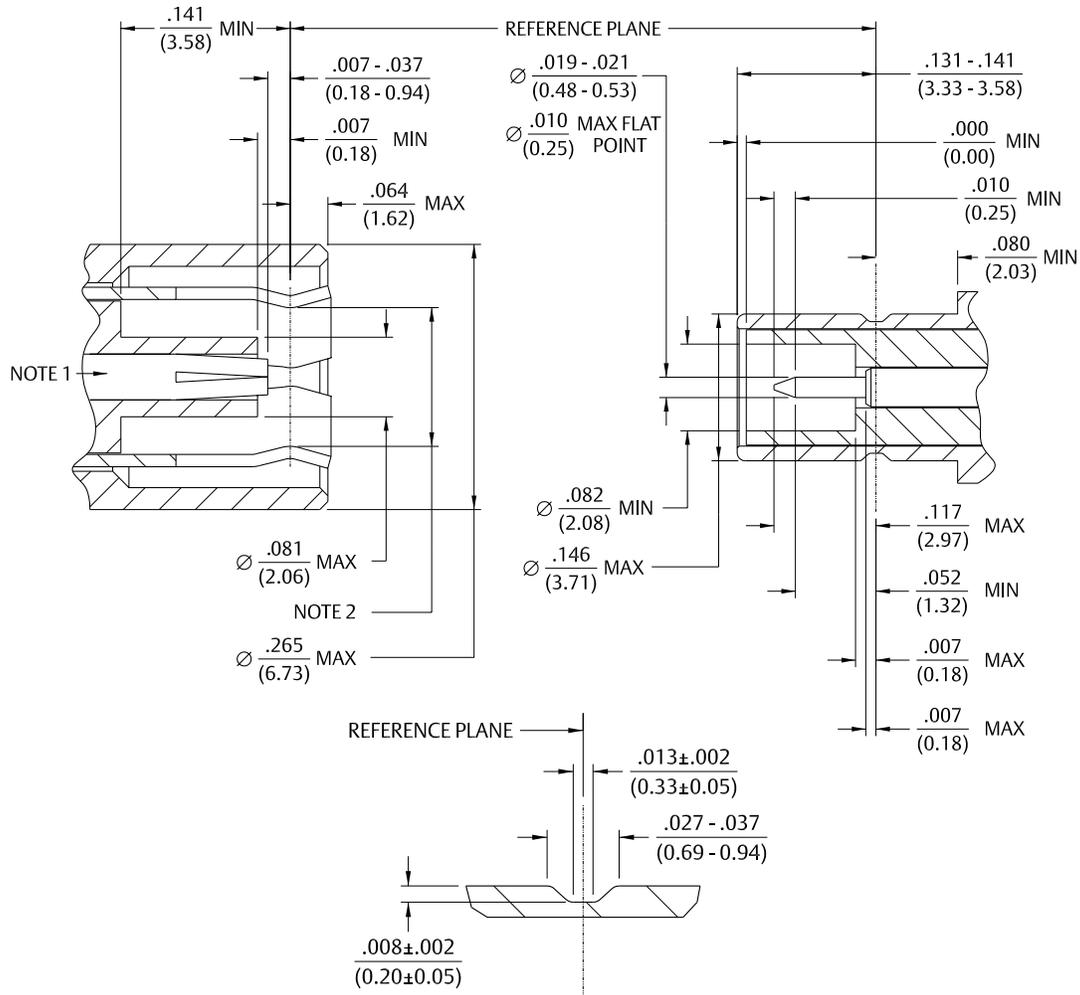

- Notes
1. ID of contact to meet VSWR, mating characteristics and connector durability when mated with a dia $.019/.021$ (0.48/0.53) male contact.
 2. Must meet the force to engage and disengage when mated with mating part.

Flexible Cable

Straight Crimp Type Plug (3-Piece) – Solder or Crimp Captivated Contact

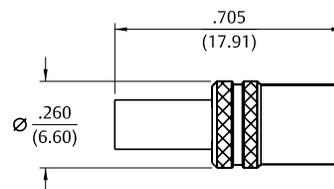

Cable Type	Gold Plated	Nickel Plated
RG-161, 174, 179, 187, 188, 316	131-3403-021	131-3403-026
RG-316 DS, 188 DS, 179 DS, 187 DS	131-3404-021	131-3404-026
RG-58, 141, 303	131-3407-011	131-3407-016

Assembly instructions page 232.

Straight Solder Type Bulkhead Plug – Solder or Crimp Captivated Contact

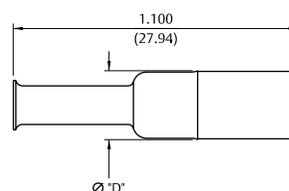

Cable Type	Gold Plated	Nickel Plated	Crimp Contact	"D"
RG-178, 196	131-3402-001	131-3402-016	No	.266 (6.76)
RG-161, 174, 179, 187, 188, 316	131-3403-001	131-3403-016	Yes	.266 (6.76)
RG-316 DS, 188 DS, 179 DS, 187 DS	131-3404-001	131-3404-016	Yes	.266 (6.76)
RG-58, 141, 303	131-3407-001	131-3407-006	Yes	.270 (6.86)

Assembly instructions page 237.

Straight Crimp Type Plug – Die Cast – Solder or Crimp Captivated Contact

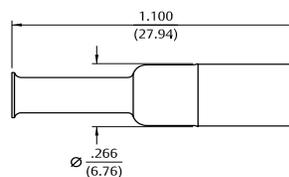

Cable Type	Gold Plated	Nickel Plated
RG-161, 174, 179, 187, 188, 316	131-1403-001	131-1403-016
RG-316 DS, 188 DS, 179 DS, 187 DS	131-1404-001	131-1404-016

Assembly instructions page 237.

Straight Crimp Type Bulkhead Plug – Solder or Crimp Captivated Contact

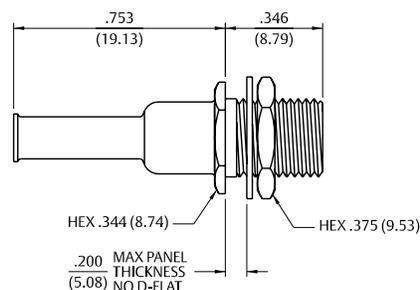

Cable Type	Gold Plated	Nickel Plated
RG-161U, 174, 179, 187, 188, 316	131-3403-401	131-3403-406
RG-316 DS, 188 DS, 179 DS, 187 DS	131-3404-401	131-3404-406

Assembly instructions page 237. Mounting hole dia. .290 (7.05).

Flexible Cable

Straight Crimp Type Jack – Solder or Crimp Captivated Contact

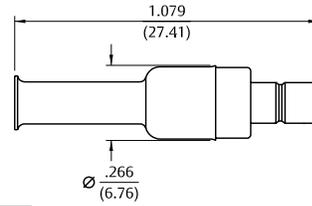

Cable Type	Gold Plated	Nickel Plated	Crimp Contact
RG-178, 196	131-3302-001	131-3302-006	No
RG-161, 174, 179, 187, 188, 316	131-3303-001	131-3303-006	Yes

Assembly instructions page 237.
Mounting hole layout figure 5 page 194.

Straight Crimp Type Bulkhead Jack – Solder or Crimp Captivated Contact

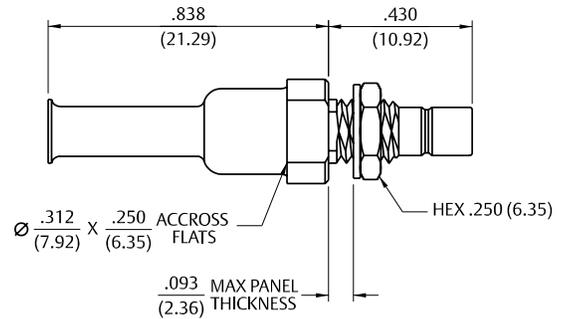

Cable Type	Gold Plated	Nickel Plated
RG-161, 174, 179, 187, 188, 316	131-3303-401	131-3303-406
RG-316 DS, 188 DS, 179 DS, 187 DS	131-3304-401	131-3304-406

Assembly instructions page 237.
Mounting hole layout figure 5 page 194.

Right Angle Crimp Type Bulkhead Jack – Captivated Contact

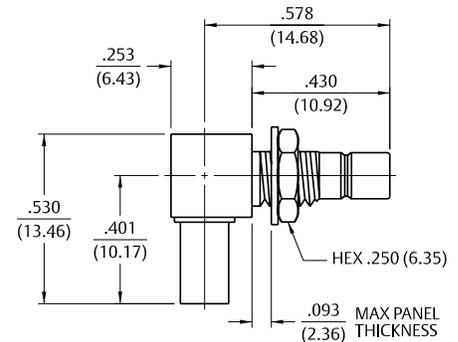

Cable Type	Gold Plated	Nickel Plated
RG-161, 174, 179, 187, 188, 316	131-3303-501	131-3303-506
RG-316 DS, 188 DS, 179 DS, 187 DS	131-3304-501	131-3304-506

Assembly instructions page 238.
Mounting hole layout figure 5 page 194.

PC Mount

Straight Jack Receptacle



Gold Plated	Nickel Plated	"A"
131-3701-201	131-3701-206	.155 (3.94)
131-3701-211	131-3701-216	.110 (2.79)

Mounting hole layout figure 4 page 194.

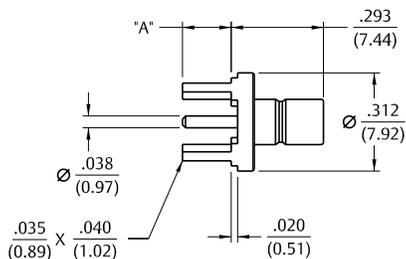

Straight Jack Receptacle



Gold Plated	Nickel Plated	"A"
131-3701-261	131-3701-266	.155 (3.94)
131-3701-271	131-3701-276	.095 (2.41)

Mounting hole layout figure 4 page 194.

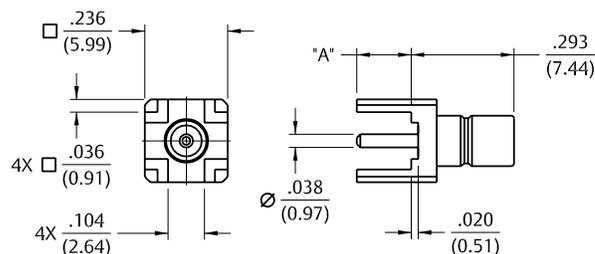

Straight Bulkhead Jack Receptacle



Gold Plated	Nickel Plated
131-3701-231	131-3701-236

Mounting hole layout figures 4 and 5 page 195.

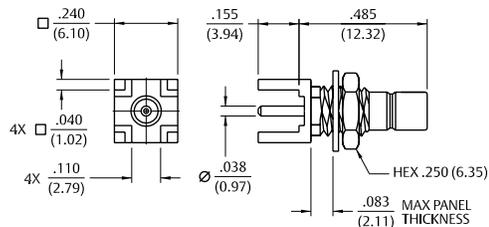

PC Mount

Right Angle Surface Mount Jack Receptacle



Gold Plated	Packaging
131-3711-301	Stock
131-3711-302	Tape and Reel, 425 pcs/reel

Mounting hole layout figure 9 page 194.
Tape and Reel .630 (16.0) component pitch .945 (24.0) wide

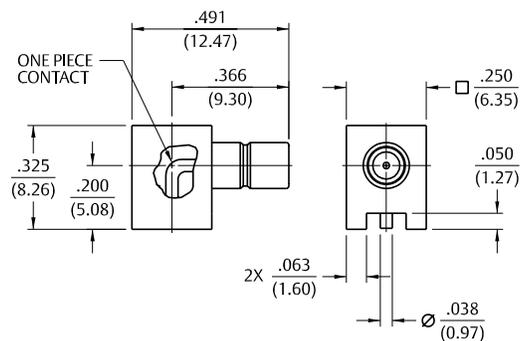

Right Angle Bulkhead Jack Receptacle



Gold Plated	Nickel Plated	"A"
131-3701-501	131-3701-506	.083 (2.11)
131-3701-511	131-3701-516	.110 (2.79)
131-3701-341	131-3701-346	.155 (3.94)

Mounting hole layout figures 4 and 5 page 194.

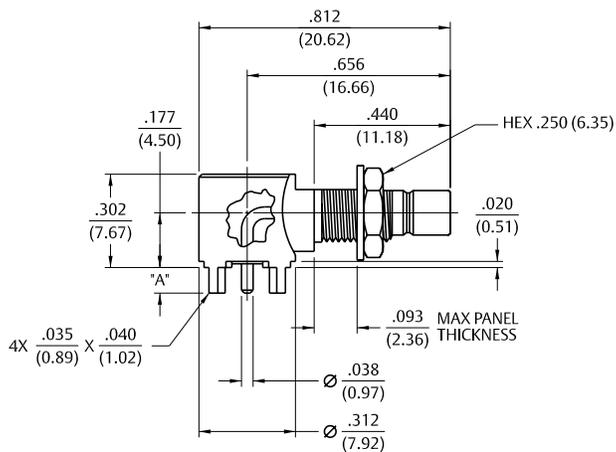

End Launch Jack Receptacle – Round Contact



Gold Plated	Nickel Plated	Board Thickness	"A"	"B"
131-3701-801	131-3701-806	.062 (1.57)	.068 (1.73)	.073 (1.85)
131-3701-821	131-3701-826	.042 (1.07)	.048 (1.22)	.093 (2.36)

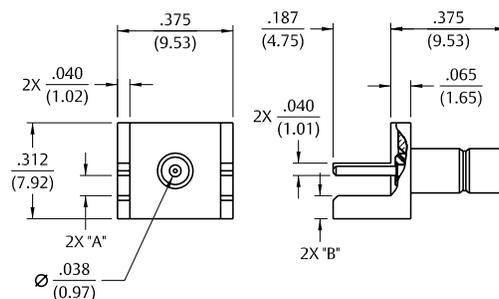

End Launch Jack Receptacle – Tab Contact



Gold Plated	Nickel Plated	Board Thickness	"A"	"B"
131-3701-811	131-3701-816	.062 (1.57)	.068 (1.73)	.083 (2.11)
131-3701-831	131-3701-836	.042 (1.07)	.048 (1.22)	.103 (2.62)

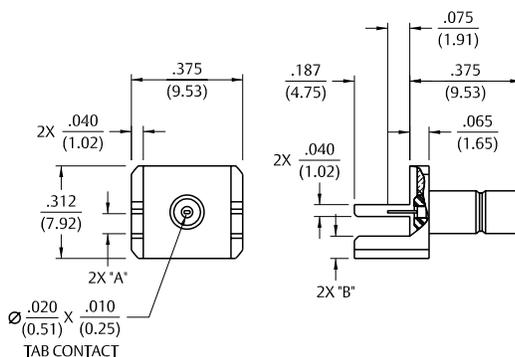

In-Series Adapters & Terminations

Jack to Bulkhead Jack Adapter



Gold Plated	Nickel Plated
131-3901-401	131-3901-406

Mounting hole layout figure 5 page 194.

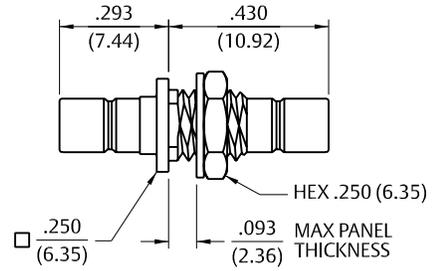

Plug to Bulkhead Jack Adapter



Gold Plated	Nickel Plated
131-3901-411	131-3901-416

Mounting hole layout figure 5 page 194.

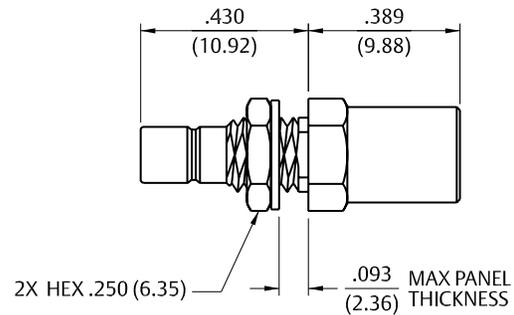

Plug Dummy Load – 50 Ohm and 75 Ohm



Gold Plated	Nickel Plated	Resistance
131-3801-811	131-3801-816	50 Ohm
131-3801-821	131-3801-826	75 Ohm

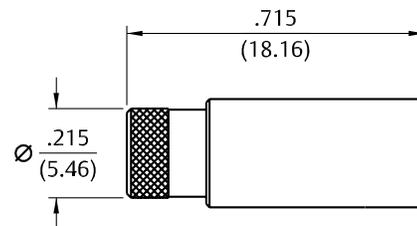

Flexible Cable

Straight Crimp Type Plug – Solder or Crimp Captivated Contact



Cable Type	Gold Plated
RG-316, 188, 174, 179, 187	131-9403-001
RG-316 DS, 188 DS, 179 DS, 187 DS	131-9404-001

Assembly instructions page 235.

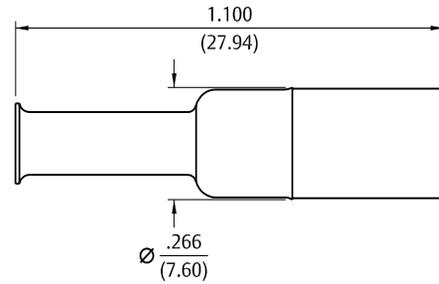

Straight Crimp Type Plug (3-piece) Solder or Crimp Captivated Contact



Cable Type	Gold Plated
RG-316, 188, 174, 179, 187	131-9403-021
RG-316 DS, 188 DS, 179 DS, 187 DS	131-9404-021

Assembly instructions page 232.

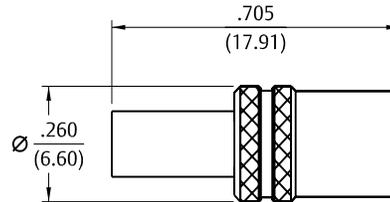

Right Angle Crimp Type Plug – Captivated Contact



Cable Type	Gold Plated
RG-316, 188, 174, 179, 187	131-9403-101
RG-316 DS, 188 DS, 179 DS, 187 DS	131-9404-101

Assembly instructions page 236.

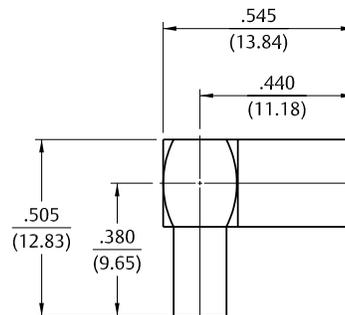

Specifications

Electrical Specifications

Impedance: 75 Ohms

Frequency Range: 0-2 GHz

VSWR: (max) (f = GHz)

RG-179, RG-59, Belden 735A:

Straight cabled connectors..... 1.25 + .04f

Right angle cabled connectors 1.35 + .04f

Adapters 1.20 + .04f

Type N Adapters 1.05 + .01f

Precision loads..... 1.05 + .01f

Uncabled receptacles, opens, shorts N/A

Working Voltage: (VRMS max) Sea Level 70K Feet

RG-179, RG-59, Belden 735A, uncabled receptacles, adapters..... 335 85

Open, shorts, loads..... N/A N/A

Dielectric Withstanding Voltage: (Vrms min at sea level)†

RG-179, RG-59, Belden 735A, uncabled receptacles, adapters 1000

Open, shorts, loads..... N/A

Insulation Resistance: 1000 megohms min

Contact Resistance: (milliohms max) Initial After Environmental

Center contact (straight cabled connectors, uncabled receptacles, opens, shorts, loads) 6.0 8.0

Center contact (right angle cabled connectors and adapters) 12.0 16.0

Outer contact (gold plated connectors) 1.0 1.5

Outer contact (nickel plated connectors)..... 2.5 3.5

Braid to body (gold plated connectors)..... 1.0 N/A

Corona Level: (Volts min at 70,000 ft)†

RG-179, RG-59, Belden 735A 250

Uncabled receptacles, adapters, open, shorts, loads..... N/A

Insertion Loss: (dB max, tested at 1.5 GHz)

Straight cabled connectors..... 0.30 dB

Right angle cabled connectors 0.60 dB

Uncabled receptacles, adapters, opens, shorts, loads..... N/A

RF Leakage: (dB min tested at 2.0 GHz)

Cabled connectors..... -55 dB

Uncabled receptacles, adapters opens, shorts, loads..... N/A

RF High Potential Withstanding Voltage:

(VRMS min, tested at 4 and 7 MHz)†

RG-179, RG-59, Belden 735A..... 700

Uncabled receptacles and adapters..... 600

Opens, shorts, loads N/A

Power Rating: (Loads) 1.0 watt at +25°C derated linearly to .5 watt at +125°C

Electrical Length: Open ± 1.5° (±5.2° relative to short)

Short ± 1.5° (±5.2° relative to open)

Adapters ±5.2° (N/A for Jack-Bulkhead Jack and N Types)

Specifications

Mating Engagement for Mini-75 Ohm SMB Series (Intermutable with Standard 50 Ohm SMB)

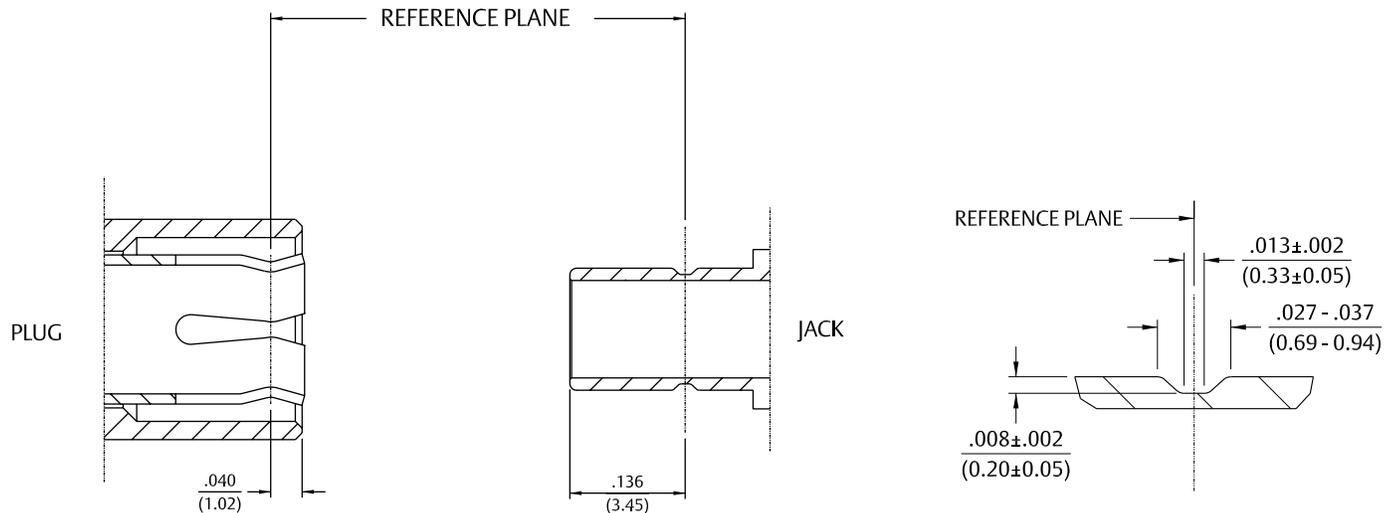
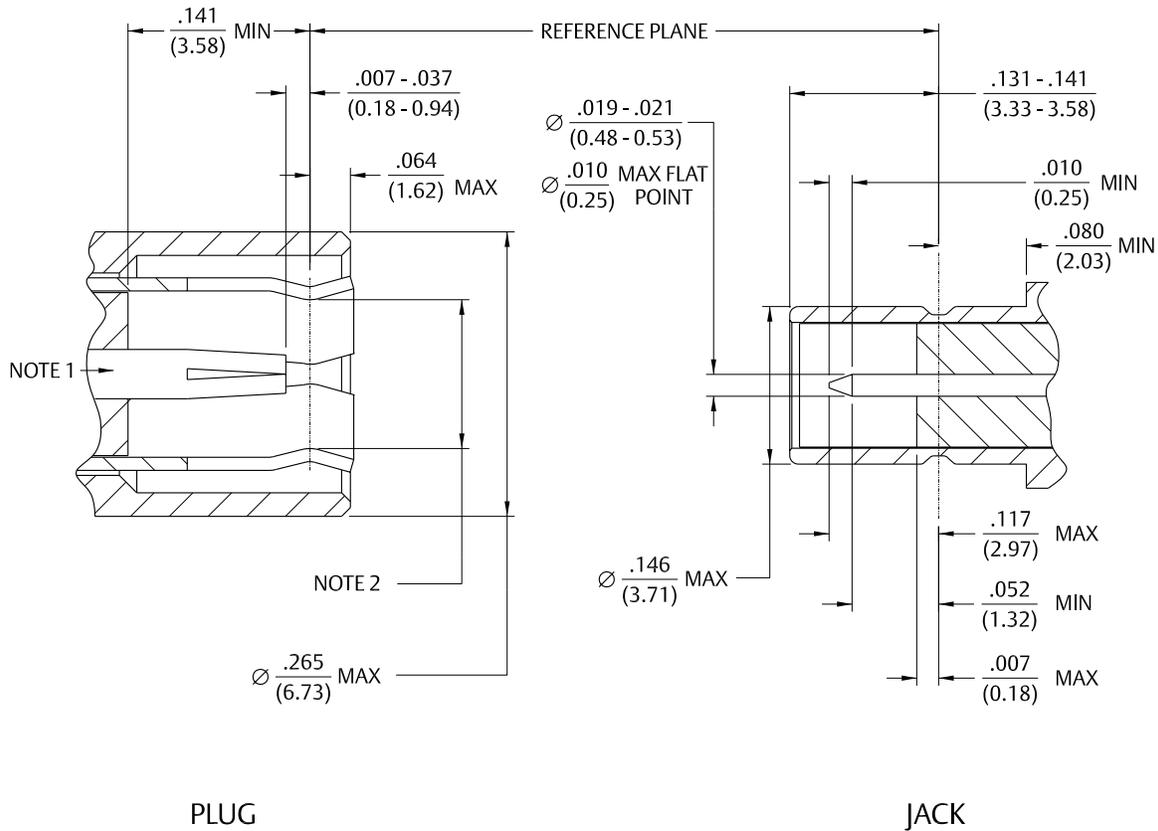

- Notes
1. ID of contact to meet VSWR, mating characteristics and connector durability when mated with a dia $.019/.021$ (0.48/0.53) male contact.
 2. Must meet the force to engage and disengage when mated with mating part.

Flexible Cable

Right Angle Crimp Type Plug – Captivated Contact



Cable Type	Gold Plated	Nickel Plated	"A"	"B"
RG-179, 187	131-8403-101	131-8403-106	.505 (12.83)	.380 (9.65)
RG-179 DS, RG-187 DS	131-8404-101	131-8404-106	.505 (12.83)	.380 (9.65)
Belden 735A	131-8445-101	131-8445-106	.750 (19.05)	.625 (15.88)

Assembly instructions page 238.

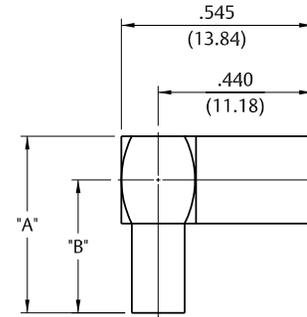

Right Angle Crimp Type Plug – Captivated Contact



Cable Type	Gold Plated	Nickel Plated
RG-59	131-8409-101	131-8409-106

Assembly instructions page 238.

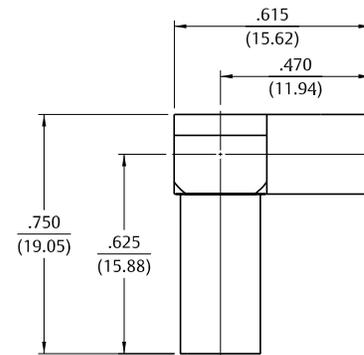

Right Angle Crimp Type Plug – Captivated Contact – Die Cast



Cable Type	Gold Plated	Nickel Plated
RG-179, 187	131-8403-111	131-8403-116
RG-179 DS, RG-187DS	131-8404-111	131-8404-116

Assembly instructions page 238.

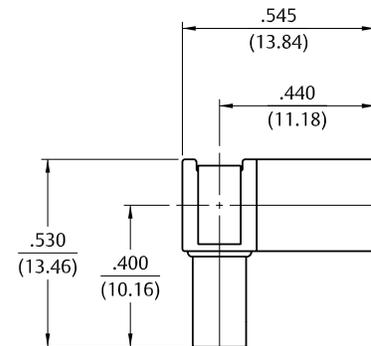

PC Mount

Straight Jack Receptacle – Surface Mount



Gold Plated	Packaging
131-8711-201	Stock
131-8711-202	Tape and Reel 750 pcs/reel

Mounting hole layout figure 11 page 194.

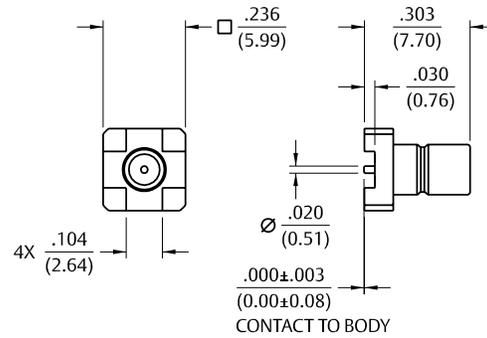

Right Angle Jack Receptacle



Gold Plated	Nickel Plated	"A"
131-8701-301	131-8701-306	.083
131-8701-311	131-8701-316	.125

Mounting hole layout figure 7 page 194.

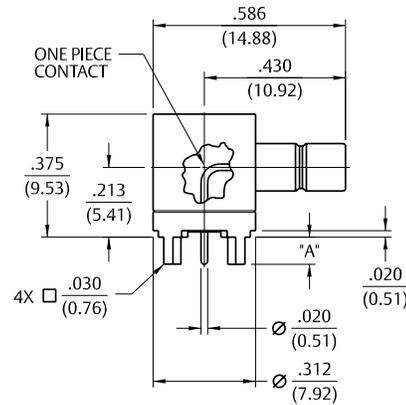

Right Angle Bulkhead Jack Receptacle



Gold Plated	Nickel Plated
131-8701-501	131-8701-506

Mounting hole layout figures 5 and 7 page 194.

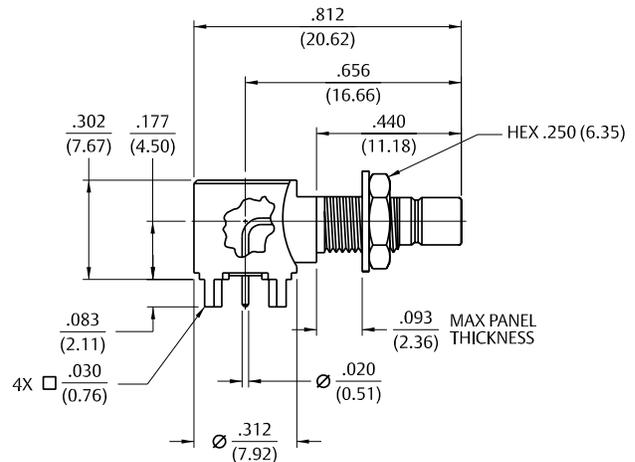

Terminations

Plug Precision Load



Gold Plated

131-8801-801

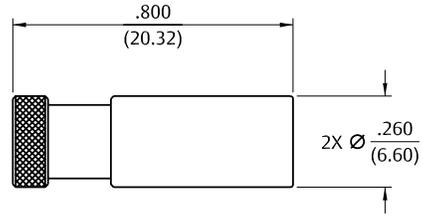

Matched Plug Open and Short



Type	Gold Plated
OPEN	131-8801-821
SHORT	131-8801-811

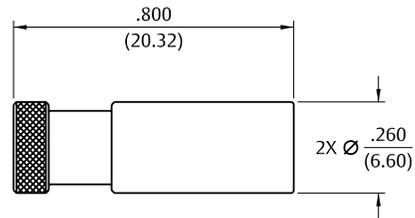

Matched Jack Open and Short



Type	Gold Plated
OPEN	131-8701-821
SHORT	131-8701-811

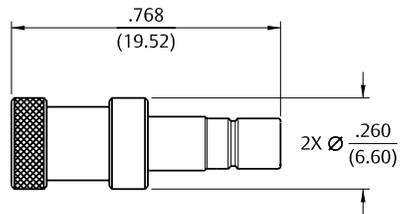

Between-Series Adapter

75 Ohm Type N Plug to Mini-75 Ohm SMB Plug Adapter



Stainless Steel Passivated

134-1069-001

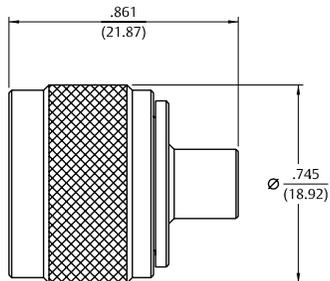

75 Ohm Type N Plug to Mini-75 Ohm SMB Jack Adapter



Stainless Steel Passivated

134-1069-011

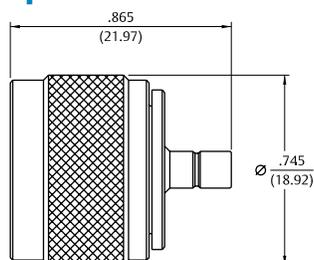

75 Ohm Type N Jack to Mini-75 SMB Plug Adapter



Stainless Steel Passivated

134-1069-021

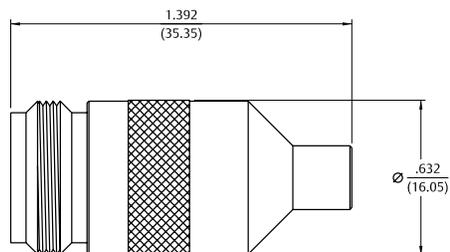

75 Ohm Type N Plug to Mini-75 Ohm SMB Jack Adapter



Stainless Steel Passivated

134-1069-031

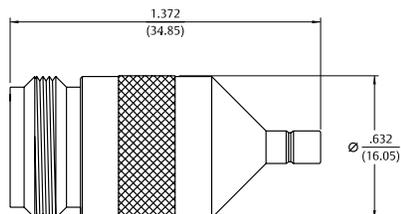

Specifications

Electrical Specifications

Impedance: 50 Ohms

Frequency Range: 0-10 GHz

VSWR: (max) (f = GHz)

	Straight Cabled Connectors	Right Angle Cabled Connectors
RG-178.....	1.25 + .04f	1.40 + .06f
RG-316 and RG-405.....	1.20 + .04f	1.30 + .04f
Uncabled receptacles.....	N/A	

Working Voltage: (VRMS max)†

	Sea Level	70K Feet
RG-178.....	.250	.60
RG-316, RG-405 uncabled receptacles.....	.335	.85

Dielectric Withstanding Voltage: (VRMS min at sea level)†

RG-178.....	750
RG-316, RG-405 uncabled receptacles.....	1000

Corona Level: (Volts min at 70,000 feet)†

RG-178.....	185
RG-316, RG-405.....	250
Uncabled receptacles.....	N/A

Insertion Loss: (dB max, tested at 4 GHz)

Straight cabled connectors.....	0.25 dB
Right angle cabled connectors.....	0.50 dB
Uncabled receptacles.....	N/A

Insulation Resistance: 1000 megohms min

Contact Resistance: (milliohms max)

	Initial	After Environmental
Center contact (straight cabled connectors and uncabled receptacles).....	6.0	8.0
Center contact (right angle cabled connectors).....	12.0	16.0
Outer contact (gold plated connectors).....	1.0	N/A
Outer contact (nickel plated connectors).....	2.5	N/A
Braid to body (gold plated connectors).....	1.0	N/A
Braid to body (nickel plated connectors).....	2.5	N/A

RF Leakage: (dB min tested at 2.5 GHz)

Cabled connectors.....	-55 dB
Uncabled receptacles.....	N/A

RF High Potential Withstanding Voltage: (VRMS min, tested at 4 and 7 MHz)†

RG-178.....	500
RG-316.....	700
Uncabled receptacles.....	600

Mechanical Specifications

Engagement Design: MIL-STD-348, Series SMC

Engagement/Disengagement Force: 16 oz-in max torque

Mating Torque: 35 to 50 oz-in

Coupling Proof Torque: 100 oz-in min

Coupling Nut Retention: 35 lbs min

Contact Retention: 4 lbs min axial force (captivated contacts)

1 oz-in min torque (uncabled receptacles)

Cable Retention:

	Axial Force* (lbs)	Torque (oz-in)
RG-178.....	10	N/A
RG-316.....	20	N/A
RG-405.....	30	16

* or cable breaking strength whichever is less

Durability: 500 cycles min

Semi-Rigid and Flexible Cable

Straight Solder Type Bulkhead Jack – Captivated Contact



Cable Type	Gold Plated	Nickel Plated
RG-405	131-6593-401	131-6593-406

Assembly instructions page 233.
Mounting hole layout figure 5 page 194.

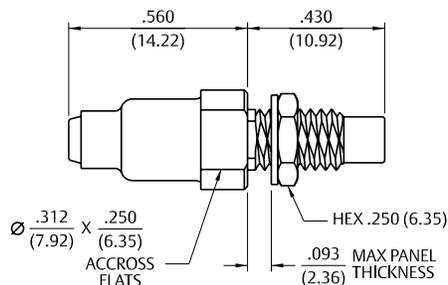

Straight Crimp Type Plug – Captivated Contact



Cable Type	Gold Plated	Nickel Plated
RG-161, 174, 188, 316	131-6403-001	131-6403-006
RG-316 DS, 188 DS	131-6404-001	131-6404-006
RG-179, 187	131-6433-001	131-6433-006

Assembly instructions page 237.

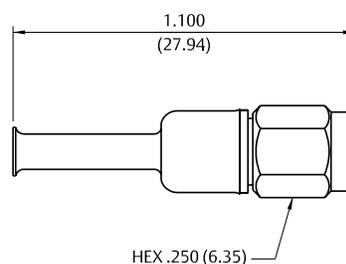

Right Angle Crimp Type Plug – Captivated Contact



Cable Type	Gold Plated	Nickel Plated
RG-161, 174, 188, 316	131-6403-101	131-6403-106
RG-316 DS, 188 DS	131-6404-101	131-6404-106
RG-179, 187	131-6433-101	131-6433-106

Assembly instructions page 238.

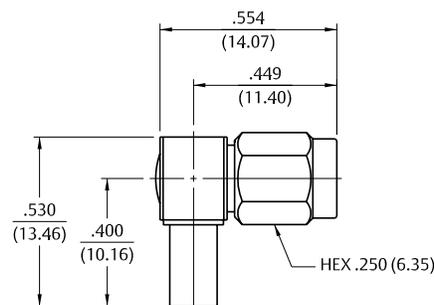

Straight Crimp Type Bulkhead Jack – Captivated Contact



Cable Type	Gold Plated	Nickel Plated
RG-161, 174, 188, 316	131-6303-401	131-6303-406
RG-316 DS, 188 DS	131-6304-401	131-6304-406
RG-179, 187	131-6333-401	131-6333-406

Assembly instructions page 237.
Mounting hole layout figure 5 page 194.

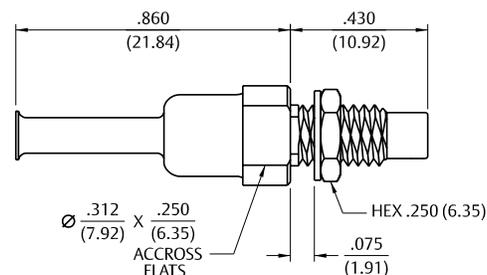

PC Mount and Bulkhead Mount

End Launch Jack Receptacle – Tab Contact



Gold Plated	Nickel Plated	Board Thickness
131-6701-831	131-6701-836	.062 (1.57)

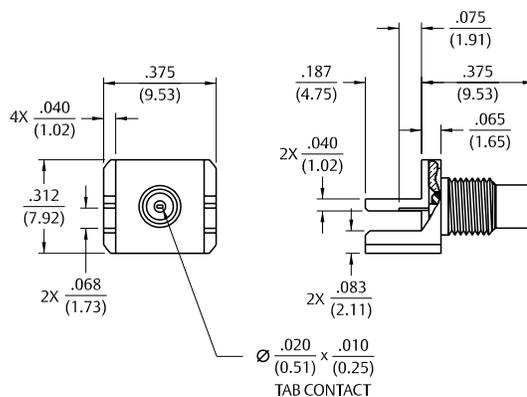

Front Mount Bulkhead Jack Receptacle



Gold Plated	Nickel Plated
131-6701-411	131-6701-416

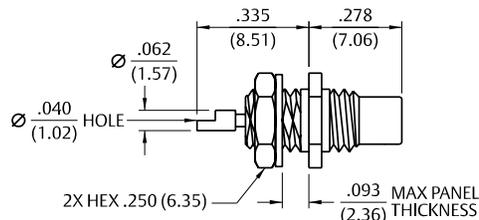

Rear Mount Bulkhead Jack Receptacle



Gold Plated	Nickel Plated
131-6701-401	131-6701-406

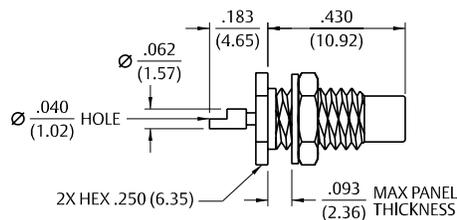

Mounting hole layout figure 5 page 194.

Introduction

Description

One of the key benefits of the SMP connector interface is its use in high frequency blind-mate applications. The design of the SMP bullet and shroud system allows for both axial and radial misalignment. The basic system is comprised of an inner “bullet” adapter, and two outer receptacles called “shrouds”. The bullet provides a flexible link between the shroud connections.

In blind-mate applications, one shroud connector will be typically specified as a snap-on interface and the other as a slide-on. This ensures that the bullet adapter remains fixed in the same shroud connector when the connection is disengaged.

The two snap-on interfaces Full Detent (FD) and Limited Detent (LD) each have different engage and disengage coupling forces. The LD is typically selected as the snap-on interface in PCB mount or blind-mate applications, while the FD is mainly used for cabled connections where higher retention forces are required.

The two slide-on interfaces Smooth Bore (SB) and Catcher’s Mitt (CM) allow for reduced connection forces as compared to the snap-on versions. The push-on interface creates a sliding connection that does not physically locate the mating reference planes, allowing for axial and radial misalignment. Both the SB and CM have the same engage/disengage forces; however the CM is typically specified as the shroud configuration in blind-mate applications as its generous lead-in chamfer helps capture and guide the bullet into place.

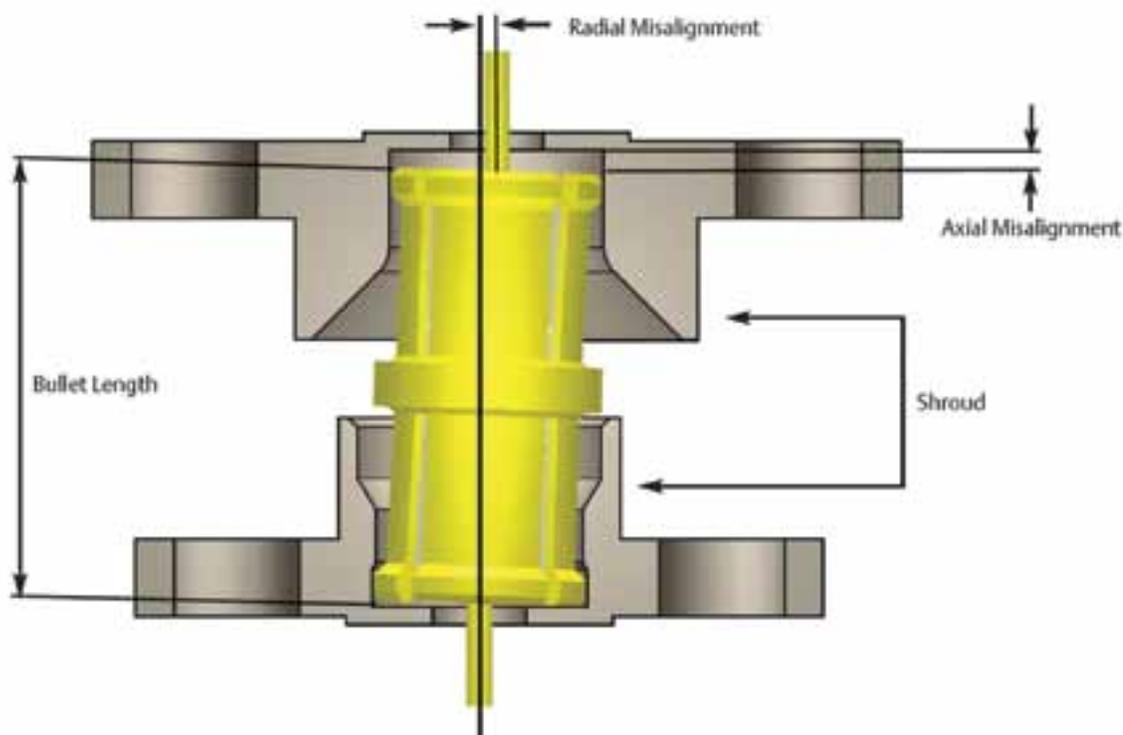

Specifications

Environmental Ratings

(Meets or exceeds the applicable paragraph of MIL-PRF-39012)

Operating Temperature:	-65°C to +165°C
Thermal Shock:	MIL-STD-202, Method 107, Condition B (except high temp +165°C or max high temp of cable)
Corrosion:	MIL-STD-202, Method 101, Condition B
Shock (specified pulse):	MIL-STD-202, Method 213, Condition I
Vibration:	MIL-STD-202, Method 204, Condition D
Moisture Resistance:	MIL-STD-202, Method 106 (except step 7b omitted)

Material Specifications

Spring Finger (female) and End Launch (male) Bodies:	Beryllium Copper per ASTM B196, Gold plated* per MIL-DTL-45204 (.00005" min)
Hermetic Seal Bodies (male):	Kovar Alloy per ASTM F15, Gold plated* per MIL-DTL-45204 (.00005" min)
All other Shroud Bodies (male):	Stainless Steel, Type 303, per ASTM A582, Passivated per MIL-DTL-14072 (EL 300)
Connector and Adapter Contacts (male and female):	Beryllium Copper per ASTM B196, Gold plated* per MIL-DTL-45204 (.00005" min)
Hermetic Seal Center Pins:	Kovar Alloy per ASTM F15, Gold plated* per MIL-DTL-45204 (.00005" min)
EMI/Anti-Rock Rings:	Beryllium Copper per ASTM B196, Gold plated* per MIL-DTL-45204 (.00003" min)
PC Mount Legs:	Brass per ASTM B16, Gold plated* per MIL-DTL-45204 (.00003" min)
Connector and Adapter Insulators:	PTFE per ASTM D1710
Hermetic Seal Glass:	Corning 7070

* All Gold plated parts include a .00005" minimum Nickel barrier layer

Typical Measured Return Loss Bullet Adapter 127-0901-801

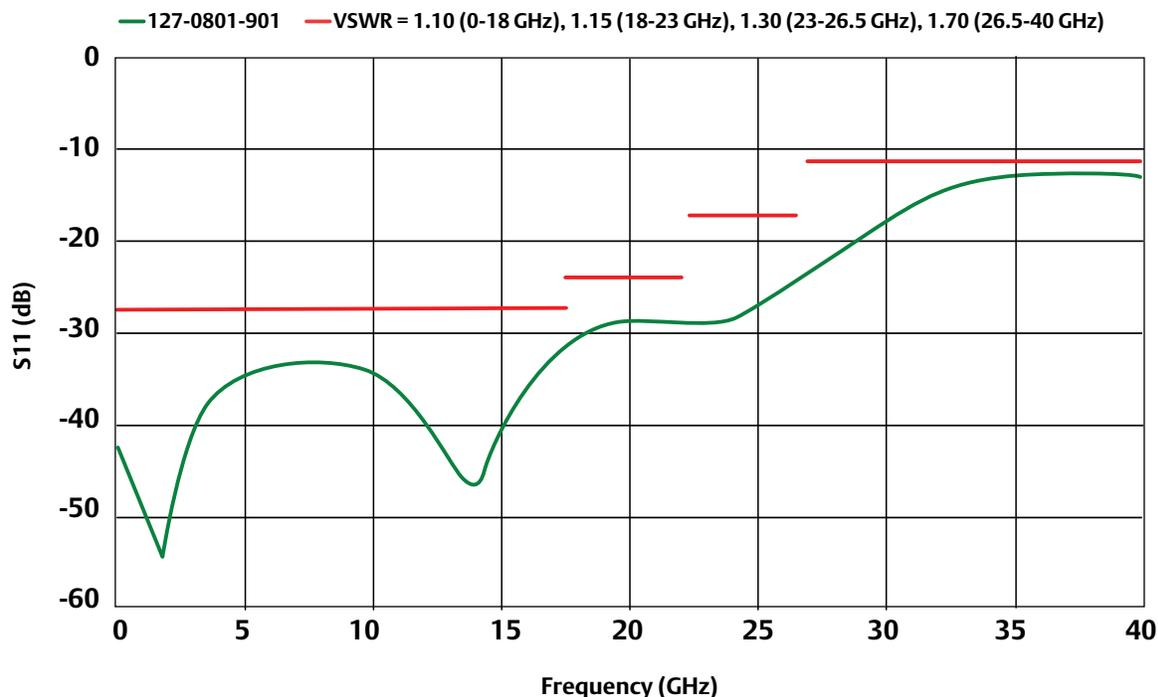

Semi-Rigid Cable and PC Mount

Female Straight Cabled, Semi-Rigid

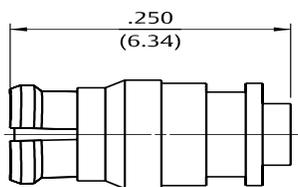

Fig 1

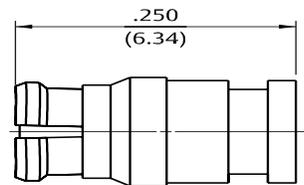
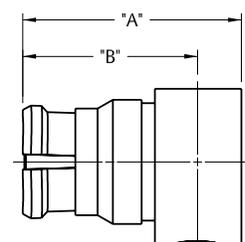
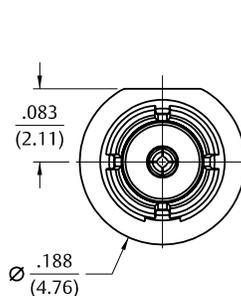

Fig 2

Cable Type	Gold Plated	Figure
M17/151	127-0692-001	1
RG-405	127-0693-001	2

* Specifications dependant on cable ratings.

Right Angle Cabled Female



Cable Type	Gold Plated	"A"	"B"
M17/151	127-0692-101	.248 (6.30)	.197 (5.00)
RG-405	127-0693-101	.271 (6.88)	.209 (5.31)

* Specifications dependant on cable ratings.

Straight PC Mount Male Receptacle

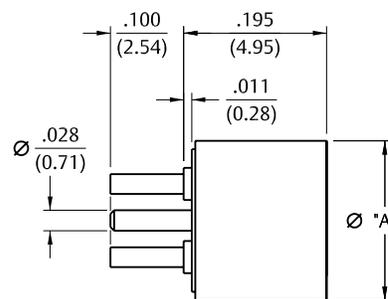
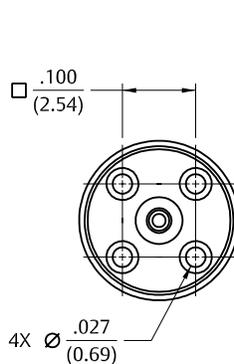

Interface	Passivated	"A"
Full Detent	127-0701-201	.218 (5.54)
Limited Detent	127-1701-201	.218 (5.54)
Smooth Bore	127-2701-201	.218 (5.54)
Catcher's Mitt	127-3701-201	.234 (5.94)

Base and legs gold plated brass.

Panel Mount and Adapters

2-Hole Flange Mount Male Field Replaceable



Interface	Passivated	Pin Size
Full Detent	127-0701-612	.012 (.030)
Limited Detent	127-1701-612	.012 (.030)
Smooth Bore	127-2701-612	.012 (.030)

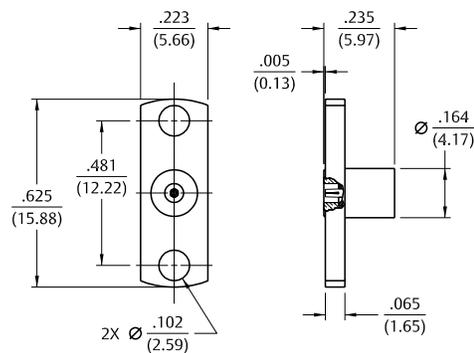

Hermetic Seal Male



Interface	Gold Plated
Full Detent	127-0711-601
Limited Detent	127-1711-601
Smooth Bore	127-2711-601

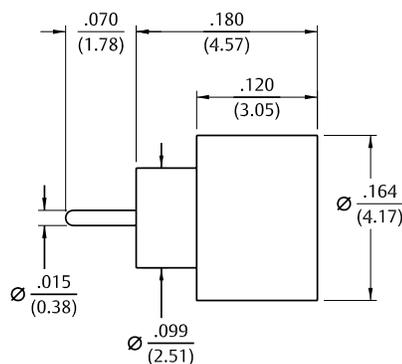

Female to Female Bullet Adapter



Gold Plated
127-0901-801

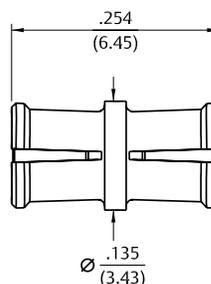

Female to Female Adapter



Gold Plated
127-0901-811

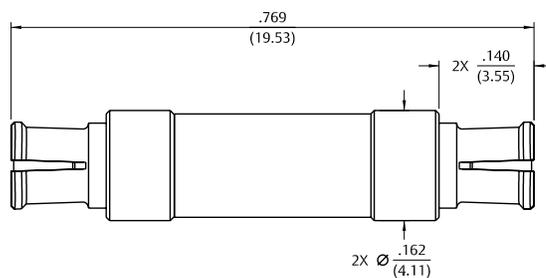

Male to Male Catcher's Mitt Adapter



Interface	Passivated
Full Detent	127-0901-821
Limited Detent	127-1901-821
Smooth Bore	127-2901-821

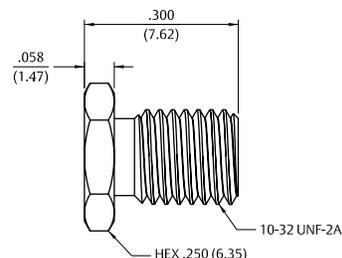

Specifications

Electrical Specifications

Impedance: 50 Ohms

Frequency Range:

Flexible Cabled Connectors and Receptacles	0-11 GHz
Semi-rigid Cabled Connectors and Receptacles	0-18 GHz

VSWR: max (f-GHz).....	0-11 GHz
Straight Flexible Cabled Connectors.....	1.30 max

	<u>0-9 GHz</u>	<u>9-11 GHz</u>
Right Angle Flexible Cabled	1.35 max	1.50 max
	<u>0-11 GHz</u>	<u>11-18 GHz</u>
RG-405 Semi-Rigid Plugs.....	1.07+.01f	<1.25 Typical
RG-402 Semi-Rigid Plugs.....	1.05+.01f	<1.25 Typical
RG-401 Semi-Rigid Plugs.....	1.06+.01f	<1.25 Typical
RG-405 Semi-Rigid Jacks	1.15+.02f	<1.50 Typical
RG-402 Semi-Rigid Jacks	1.10+.02f	<1.50 Typical
RG-401 Semi-Rigid Jacks	1.10+.02f	<1.50 Typical

Adapters.....	1.05+.01f
Uncabled Receptacles	N/A

Working Voltage: (VRMS max)†	<u>Sea Level</u>	<u>70K Feet</u>
RG-316, 316 DS	250	65
RG-58, 142, 405	335	85
RG-402	500	125
RG-213, 214, 401, LMR-400.....	1000	250
Uncabled Receptacles and Adapters	1000	250

Dielectric Withstanding Voltage: (VRMS min at sea level)†	
RG-316, 316 DS.....	750
RG-58, 142, 405	1000
RG-402	1500
RG-213, 214, 401, LMR-400.....	2500
Uncabled Receptacles and Adapters.....	2500

Insulation Resistance: 5000 Megohms min

Contact Resistance: (milliohms max)

Center Contact	<u>Initial</u>	<u>After Environmental</u>
Straight Cabled Connectors (non-captivated).....	1.0	1.5
Straight Cabled Connectors (captivated)	2.5	3.0
Right Angle Cabled Connectors	2.5	3.0
Uncabled Receptacles and Adapters.....	1.0	1.5
Outer Contact	0.2	N/A
Braid to Body (Flexible Cabled Connectors Only)	0.05	N/A

Corona Level: (Volts min at 70K feet)†

RG-316, 316 DS.....	190
RG-58, 142, 405	250
RG-402	375
RG-213, 214, 401, LMR-400 and Adapters	500
Uncabled Receptacles	N/A

Insertion Loss: (dB max, tested at 9 GHz)

Straight Flexible Cabled Connectors	0.15 max
Right Angle Flexible Cabled Connectors.....	0.30
Semi-rigid Cabled Connectors and Adapters	$0.05\sqrt{f(\text{GHz})}$
Uncabled Receptacles	N/A

RF Leakage: (dB min, tested at 2.5 GHz)

Cabled Connectors and Adapters	-90
Uncabled Receptacles	N/A

RF High Potential Withstanding Voltage: (Vrms min, tested at 4 and 7 MHz)†

RG-316, 316 DS	500
RG-58, 142, 405	670
RG-402	1000
RG-213, 214, 401, LMR-400	1500
Uncabled Receptacles and Adapters	1500

IMP3: Typically <-90 dBm (tested per IEC Guidelines using 20W inputs swept over 1930-1990 MHz)

† Avoid user injury due to misapplication. See safety advisory definitions inside front cover.

Specifications

Environmental Specifications

(Meets or Exceeds the Applicable Paragraph of MIL-PRF-39012)

Temperature Range:	-65°C to +165°C
Thermal Shock:	MIL-STD-202, Method 107, Condition B (except +85°C high temperature)
Corrosion:	MIL-STD-202, Method 101, Condition B
Shock:	MIL-STD-202, Method 213, Condition I
Vibration:	MIL-STD-202, Method 204, Condition B
Moisture Resistance:	MIL-STD-202, Method 106

Material Specifications

Bodies:	Crimp – Brass per ASTM B16, Tri-Alloy (Cu/Sn/Zn) plated (.0001" min) Solder – Brass per ASTM B16, Gold plated* per SAE-AMS2423 (.00001" min) Adapter – Brass per ASTM B16, Tri-Alloy (Cu/Sn/Zn) or Nickel per QQ-N-290 plated (.0001" min)
Contacts:	Male – Brass per ASTM B16, Gold plated* per MIL-G-45204 (.00005" min) Female – Beryllium Copper per ASTM B196, Gold plated* per MIL-DTL-45204 (.00005" min) Adapter – Beryllium Copper per ASTM B196, Gold plated* per MIL-DTL-45204 (.00005" min)
Insulators:	PTFE Fluorocarbon per ASTM D1710 and ASTM D1457
Gaskets:	Silicon Rubber per A-A-59588A
Crimp Sleeves:	Copper per ASTM B301, Tri-Alloy (Cu/Sn/Zn) plated (.0001" min)
End Caps:	Brass per ASTM B16, Tri-Alloy (Cu/Sn/Zn) plated (.0001" min)
Nut Retention Spring (Plugs):	Beryllium Copper per ASTM B196, un-plated
Mounting Nut (Bulkhead Jacks):	Brass per ASTM B16, Nickel plated per SAE-AMS2423 (.0001" min)
Lock Washer (Bulkhead Jacks):	Steel, Zinc plated (.0001" min)

* All Gold plated parts include a .00005" minimum Nickel under plated barrier layer

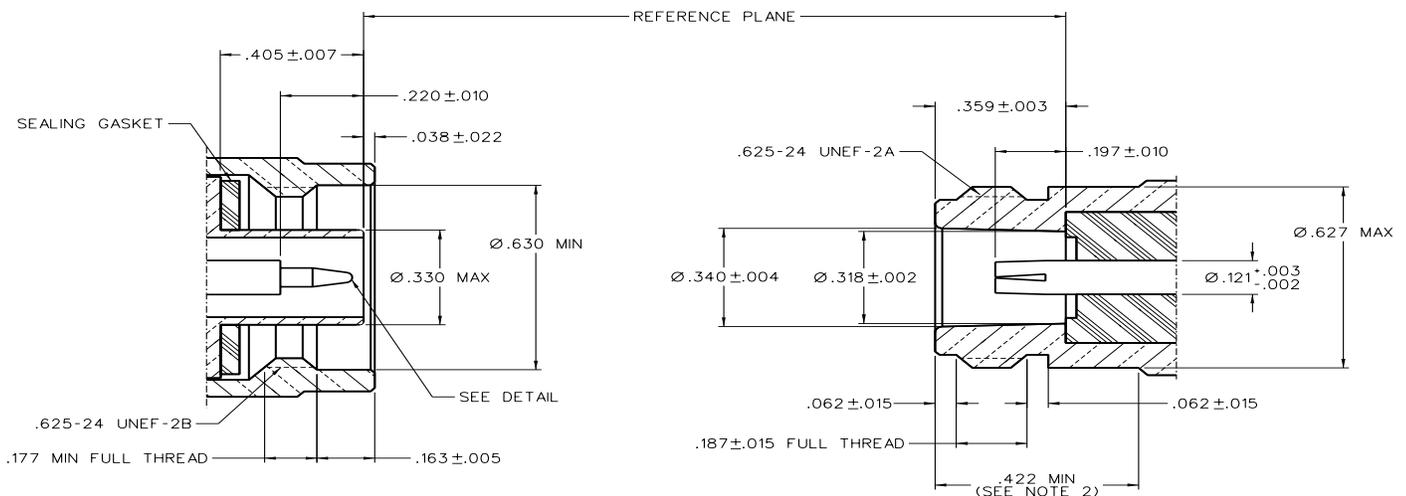

NOTES:

1. THIS INTERFACE SHALL MEET THE GAUGE REQUIREMENTS AS SPECIFIED IN MIL-PRF-39012/1G AND /2G.
2. CLEARANCE FOR MATING CONNECTOR COUPLING NUT.

Flexible Cable

Straight Crimp Type Plug – Solder or Crimp Contact



Cable Type	Tri-Alloy Plated	Figure
RG-161, 174, 188, 316	138-4403-007	1
RG-188 DS, RG-316 DS	138-4404-007	1
RG-58, 141, 303	138-4407-007	2
RG-55, 142, 223, 400	138-4408-007	2
RG-8, 213	138-4416-007	3
RG-9, 214	138-4418-007	3
LMR-400, BELDEN 9913	138-4449-007	3

Assembly instructions page 242 and 243.

* Tri-Alloy plated coupling nut

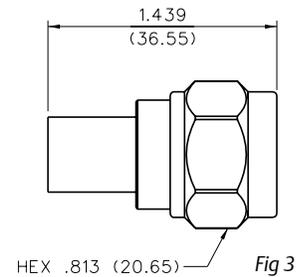
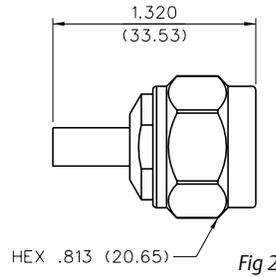
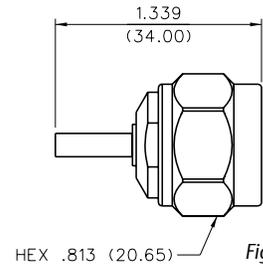

Right Angle Crimp Type Plug – Captivated Contact



Cable Type	Tri-Alloy Plated	Figure	"A"	"B"
RG-161, 174, 188, 316	138-4403-107	1	1.227 (31.17)	0.977 (24.82)
RG-188 DS, RG-316 DS	138-4404-107	1	1.227 (31.17)	0.977 (24.82)
RG-58, 141, 303	138-4407-107	2	1.253 (31.83)	1.003 (25.48)
RG-55, 142, 223, 400	138-4408-107	2	1.253 (31.83)	1.003 (25.48)
RG-8, 213	138-4416-107	2	1.365 (34.67)	1.115 (28.32)
RG-9, 214	138-4418-107	2	1.365 (34.67)	1.115 (28.32)

Assembly instructions page 244 and 245.

* Tri-Alloy plated coupling nut

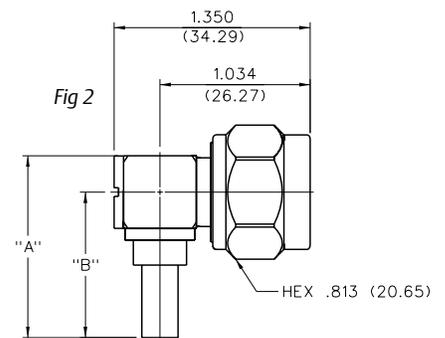
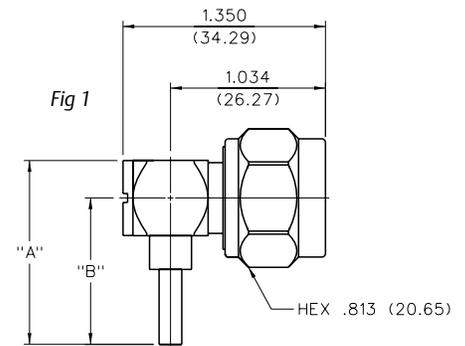

Straight Crimp Type Bulkhead Jack – Solder or Crimp Contact



Cable Type	Tri-Alloy Plated	"A"
RG-161, 174, 188, 316	138-4303-407	.943 (23.95)
RG-188 DS, RG-316 DS	138-4304-407	.943 (23.95)
RG-58, 141, 303	138-4307-407	.943 (23.95)
RG-55, 142, 223, 400	138-4308-407	.943 (23.95)
RG-8, 213	138-4316-407	.997 (25.32)
RG-9, 214	138-4318-407	.997 (25.32)
LMR-400, BELDEN 9913	138-4349-407	.997 (25.32)

Assembly instructions page 248 and 251.

Mounting hole layout figure 9 page 194.

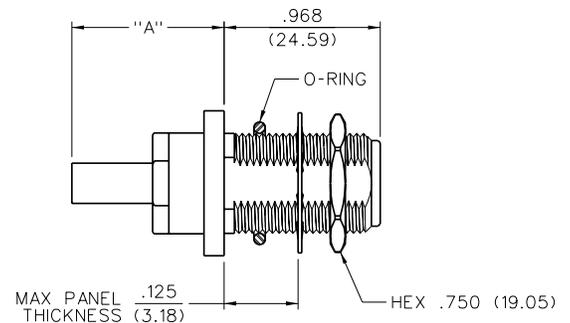

In-Series Adapters

Jack to Bulkhead Jack Adapter



Tri-Alloy Plated

138-4901-407

Mounting hole layout figure 1 page 194.

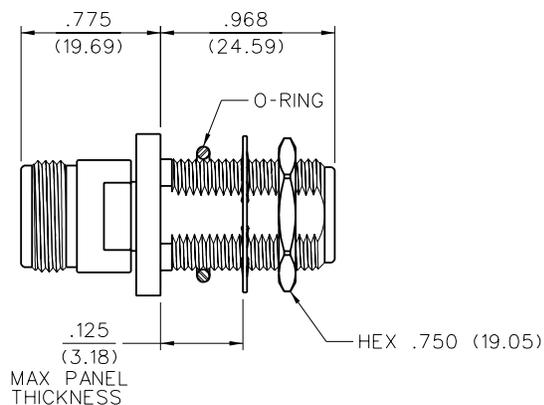

Plug to Plug Adapter



Tri-Alloy Plated

138-4901-817

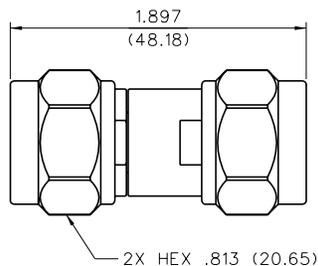

Specifications

Electrical Specifications

Engagement Design:	Impedance: 29 ohms
Frequency Range:	0 - 2 GHz
Working Voltage:	300 VRMS†
Dielectric Withstanding Voltage:	2000 VDC†
Contact Resistance:	Center Contact: 6 milliohms Outer conductor: 2.5 milliohms

Mechanical Specifications

Insertion Force:	Inner conductor: 32 oz. max. 2 oz. min. Outer conductor: 48 oz. max. 6 oz. min.
Durability:	250 cycles

Environmental Ratings

Temperature Range:	-65° C to + 85° C
Corrosion:	Salt spray, 24 hours
Shock:	Method 213, Test Condition B, MIL-STD-202
Vibration:	Method 204, Test Condition B, MIL-STD-202

Material Specifications

Contact:	Beryllium copper per QQ-C-533/530
Insulator Material:	TFE Fluorocarbon per L-P-403
Finish:	Center Contact and Body: Gold

SHIELDED TEST JACK INTERFACE -
TYPICAL PROBE TYPE

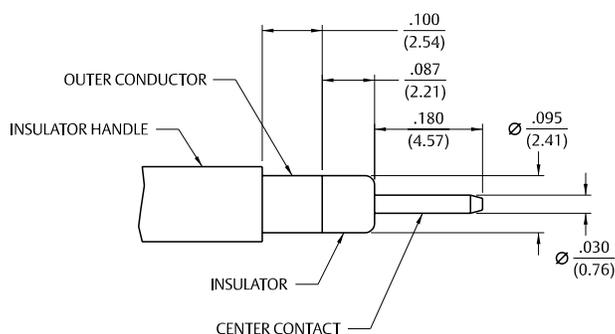
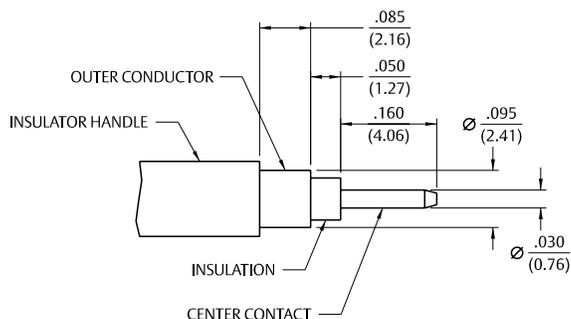

Flexible Cable & PC Mount

Flexible Cable – Straight Crimp Type End Launch

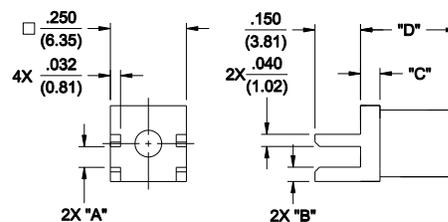

Cable Type	Gold Plated	Board Thickness	"A"	"B"	"C"	"D"
RG-316/U, 188, 174, 161, 179, 187	142-0003-801	0.062 (1.57)	0.068 (1.73)	0.046 (1.02)	0.055 (1.40)	0.310 (7.87)
RG-316 DS, 188 DS, 179 DS, 187 DS	142-0004-801	0.062 (1.57)	0.068 (1.73)	0.046 (1.02)	0.065 (1.65)	0.320 (8.13)
RG-58/U, 141, 303	142-0007-801	0.062 (1.57)	0.068 (1.73)	0.037 (1.65)	0.065 (1.65)	0.320 (8.13)
RG-142/U, 55, 223, 400	142-0008-801	0.062 (1.57)	0.068 (1.73)	0.037 (1.65)	0.065 (1.65)	0.320 (8.13)
RG-178/U, 196	142-0002-811	0.047 (1.19)	0.053 (1.35)	0.065 (1.65)	0.065 (1.65)	0.320 (8.13)
RG-316/U, 188, 174, 161, 179, 187	142-0003-811	0.047 (1.19)	0.053 (1.35)	0.061 (1.55)	0.065 (1.65)	0.320 (8.13)
RG-316 DS, 188 DS, 179 DS, 187 DS	142-0004-811	0.047 (1.19)	0.053 (1.35)	0.061 (1.55)	0.065 (1.65)	0.320 (8.13)
RG-58/U, 141, 303	142-0007-811	0.047 (1.19)	0.053 (1.35)	0.052 (1.32)	0.065 (1.65)	0.320 (8.13)
RG-142/U, 55, 223, 400	142-0008-811	0.047 (1.19)	0.053 (1.35)	0.052 (1.32)	0.065 (1.65)	0.320 (8.13)

Assembly instructions page 253.

Flexible Cable – Straight Crimp Type Surface Mount End Launch



Cable Type	Gold Plated
RG-178/U, 196	142-0002-821

Recommended land pattern figure 12 page 194.
Assembly instructions page 254.

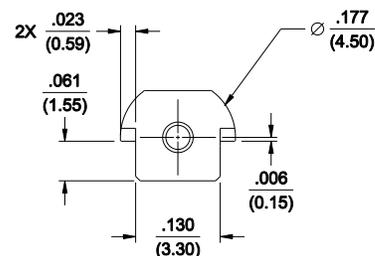

Horizontal



Gold Plated

129-0701-302

Mounting hole layout figure 15 page 195.

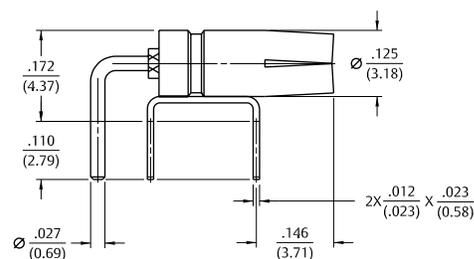

Vertical



Gold Plated

129-0701-202

Mounting hole layout figure 16 page 195.

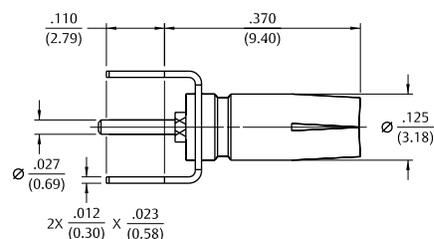

SMA to SMB

SMA Plug to SMB Jack Adapter



Gold Plated

134-1012-011

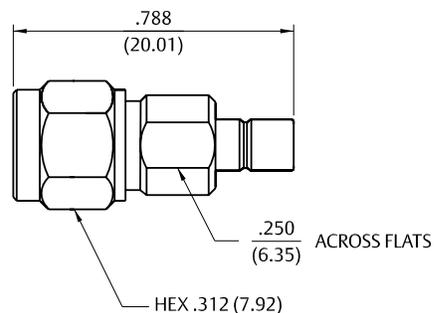

SMA Plug to SMB Plug Adapter



Gold Plated

134-1012-021

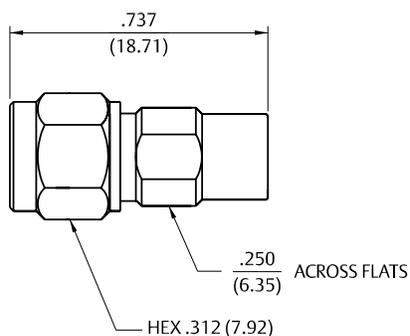

SMA Jack to SMB Plug Adapter



Gold Plated

134-1012-041

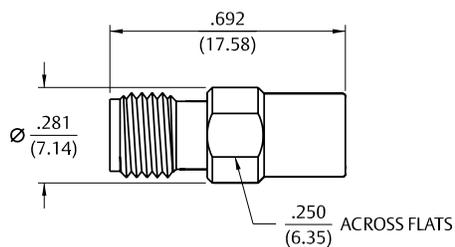

SMA to MMCX

SMA Plug to MMCX Jack Adapter



Gold Plated

134-1019-151

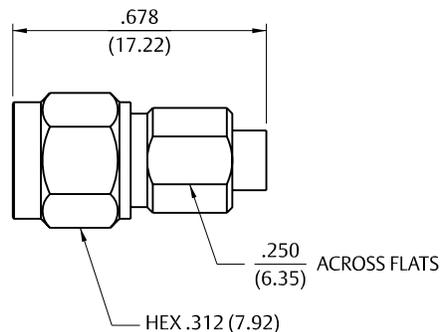

SMA Plug to MMCX Plug Adapter



Gold Plated

134-1019-161

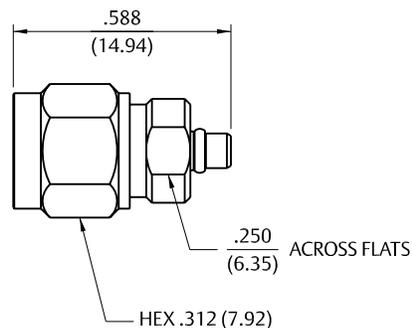

SMA Jack to MMCX Jack Adapter



Gold Plated

134-1019-171

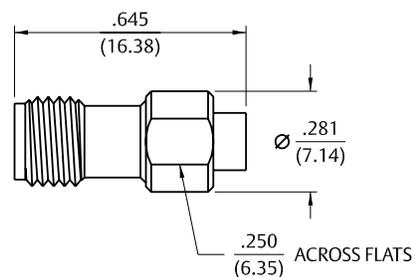

SMA Jack to MMCX Plug Adapter



Gold Plated

134-1019-181

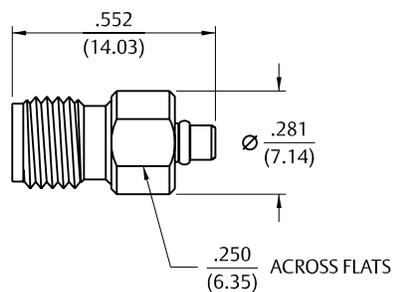

Specifications

Electrical Ratings

Electrical ratings of a cable assembly are determined by the limiting connector type and cable size.

Connector	Cable	Connector Impedance (Ohms)	Frequency (GHz)	Dielectric With-standing Voltage (VRMS)	Working Voltage (VRMS)
MMCX	RG-178	50	6	500 Vms	170 Vms
	RG-316	50	6	500 Vms	170 Vms
MCX	RG-178	50	6	750 Vms	250 Vms
	RG-316	50	6	1000 Vms	335 Vms
	RG-316DS	50	6	1000 Vms	335 Vms
MCX 75 Ohm	RG-179	75	6	1000 Vms	335 Vms
	BELDEN 735A	75	6	1000 Vms	335 Vms
SMA	RG-178	50	12.4	500 Vms	170 Vms
	RG-316	50	12.4	750 Vms	250 Vms
	RG-316DS	50	12.4	750 Vms	250 Vms
	RG-58	50	12.4	1000 Vms	335 Vms
	RG-142	50	12.4	1000 Vms	335 Vms
	Hand-Formable .086	50	26.5	1000 Vms	335 Vms
	Hand-Formable .141	50	26.5	1500 Vms	500 Vms
SMB	RG-178	50	4	750 Vms	250 Vms
	RG-316	50	4	1000 Vms	335 Vms
SMB Mini 75 Ohm	RG-179	75	2	1000 Vms	335 Vms
	RG-179DS	75	2	1000 Vms	335 Vms
	BELDEN 735A	75	2	1000 Vms	335 Vms
BNC	RG-58	50	4	1500 Vms	500 Vms
	BELDEN 8218	50	4	1500 Vms	500 Vms
	RG-59	50	4	1500 Vms	500 Vms
	RG-59 PLENUM	50	4	1500 Vms	500 Vms
BNC 75 Ohm	BELDEN 8218	75	3	1500 Vms	500 Vms
	RG-59	75	3	1500 Vms	500 Vms
	BELDEN 8281	75	3	1500 Vms	500 Vms
	COMM SCOPE 735	75	3	1500 Vms	500 Vms
	BELDEN 735A	75	3	1500 Vms	500 Vms
	BELDEN 734A	75	3	1500 Vms	500 Vms
	BELDEN 1694A	75	3	1500 Vms	500 Vms
N	RG-58	50	11	1500 Vms	500 Vms
	RG-142	50	11	1500 Vms	500 Vms
	RG-8	50	11	1500 Vms	500 Vms
	RG-213	50	11	1500 Vms	500 Vms

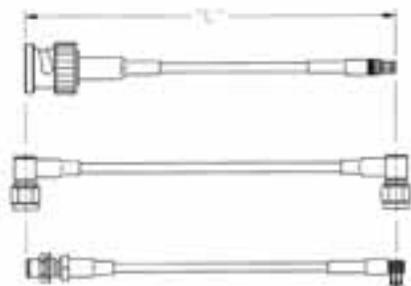

Emerson Connectivity Solutions cable length applies to the end of straight connectors. The length is applied to the vertical centroid of right angle connectors.

MCX Straight Plug to MCX Straight Plug



Part No.	Cable Type	Cable Length	Connector A	Connector B
415-0014-006	RG -178	6"	133-3402-021	133-3402-021
415-0014-012	RG -176	12"	133-3402-021	133-3402-021
415-0014-018	RG -178	18"	133-3402-021	133-3402-021
415-0014-024	RG -178	24"	133-3402-021	133-3402-021
415-0014-030	RG -178	30"	133-3402-021	133-3402-021
415-0014-036	RG -178	36"	133-3402-021	133-3402-021
415-0018-006	RG -316	6"	133-3403-001	133-3403-001
415-0018-012	RG -316	12"	133-3403-001	133-3403-001
415-0018-018	RG -316	18"	133-3403-001	133-3403-001

Part No.	Cable Type	Cable Length	Connector A	Connector B
415-0018-024	RG -316	24"	133-3403-001	133-3403-001
415-0018-030	RG -316	30"	133-3403-001	133-3403-001
415-0018-036	RG -316	36"	133-3403-001	133-3403-001
415-0020-006	RG -316	6"	133-3404-001	133-3404-001
415-0020-012	RG-316DS	12"	133-3404-001	133-3404-001
415-0020-018	RG-316DS	18"	133-3404-001	133-3404-001
415-0020-024	RG-316DS	24"	133-3404-001	133-3404-001
415-0020-030	RG-316DS	30"	133-3404-001	133-3404-001
415-0020-036	RG-316DS	36"	133-3404-001	133-3404-001

MCX Straight Plug to MCX Straight Bulkhead Jack



Part No.	Cable Type	Cable Length	Connector A	Connector B
415-0016-006	RG -316	6"	133-3403-001	133-3303-401
415-0016-012	RG -316	12"	133-3403-001	133-3303-401
415-0016-018	RG -316	18"	133-3403-001	133-3303-401

Part No.	Cable Type	Cable Length	Connector A	Connector B
415-0016-024	RG -316	24"	133-3403-001	133-3303-401
415-0016-030	RG -316	30"	133-3403-001	133-3303-401
415-0016-036	RG -316	36"	133-3403-001	133-3303-401

MCX Straight Plug to MCX Right Angle Plug



Part No.	Cable Type	Cable Length	Connector A	Connector B
415-0017-006	RG -316	6"	133-3403-001	133-3403-101
415-0017-012	RG -316	12"	133-3403-001	133-3403-101
415-0017-018	RG -316	18"	133-3403-001	133-3403-101

Part No.	Cable Type	Cable Length	Connector A	Connector B
415-0017-024	RG -316	24"	133-3403-001	133-3403-101
415-0017-030	RG -316	30"	133-3403-001	133-3403-101
415-0017-036	RG -316	36"	133-3403-001	133-3403-101

MCX Right Angle Plug to MCX Right Angle Plug



Part No.	Cable Type	Cable Length	Connector A	Connector B
415-0015-006	RG -178	6"	133-3402-101	133-3402-101
415-0015-012	RG -178	12"	133-3402-101	133-3402-101
415-0015-018	RG -178	18"	133-3402-101	133-3402-101
415-0015-024	RG -178	24"	133-3402-101	133-3402-101
415-0015-030	RG -178	30"	133-3402-101	133-3402-101
415-0015-036	RG -178	36"	133-3402-101	133-3402-101
415-0012-006	RG -316	6"	133-3403-101	133-3403-101

Part No.	Cable Type	Cable Length	Connector A	Connector B
415-0021-006	RG-316DS	6"	133-3404-101	133-3404-101
415-0021-012	RG-316DS	12"	133-3404-101	133-3404-101
415-0021-018	RG-316DS	18"	133-3404-101	133-3404-101
415-0021-024	RG-316DS	24"	133-3404-101	133-3404-101
415-0021-030	RG-316DS	30"	133-3404-101	133-3404-101
415-0021-036	RG-316DS	36"	133-3404-101	133-3404-101



Hand Formable SMA Straight Plug to SMA Straight Plug

Part No.	Cable Type	Cable Length	Connector A	Connector B
415-0081-003	Hand Formable .086	3"	142-0693-001	142-0693-001
415-0081-004	Hand Formable .086	4"	142-0693-001	142-0693-001
415-0081-005	Hand Formable .086	5"	142-0693-001	142-0693-001
415-0081-006	Hand Formable .086	6"	142-0693-001	142-0693-001
415-0081-007	Hand Formable .086	7"	142-0693-001	142-0693-001

Part No.	Cable Type	Cable Length	Connector A	Connector B
415-0081-008	Hand Formable .086	8"	142-0693-001	142-0693-001
415-0081-012	Hand Formable .086	12"	142-0693-001	142-0693-001
415-0081-018	Hand Formable .086	18"	142-0693-001	142-0693-001
415-0081-024	Hand Formable .086	24"	142-0693-001	142-0693-001



Hand Formable SMA Straight Plug to SMA Straight Plug

Part No.	Cable Type	Cable Length	Connector A	Connector B
415-0082-003	Hand Formable .141	3"	142-0694-001	142-0694-001
415-0082-004	Hand Formable .141	4"	142-0694-001	142-0694-001
415-0082-005	Hand Formable .141	5"	142-0694-001	142-0694-001
415-0082-006	Hand Formable .141	6"	142-0694-001	142-0694-001
415-0082-007	Hand Formable .141	7"	142-0694-001	142-0694-001

Part No.	Cable Type	Cable Length	Connector A	Connector B
415-0082-008	Hand Formable .141	8"	142-0694-001	142-0694-001
415-0082-012	Hand Formable .141	12"	142-0694-001	142-0694-001
415-0082-018	Hand Formable .141	18"	142-0694-001	142-0694-001
415-0082-024	Hand Formable .141	24"	142-0694-001	142-0694-001



SMA Straight Plug to SMA Straight Bulkhead Jack

Part No.	Cable Type	Cable Length	Connector A	Connector B
415-0031-006	RG-316	6"	142-0403-011	142-0303-411
415-0031-012	RG-316	12"	142-0403-011	142-0303-411
415-0031-018	RG-316	18"	142-0403-011	142-0303-411
415-0031-024	RG-316	24"	142-0403-011	142-0303-411
415-0031-036	RG-316	36"	142-0403-011	142-0303-411
415-0031-048	RG-316	48"	142-0403-011	142-0303-411
415-0035-006	RG-316 DS	6"	142-0404-011	142-0304-411
415-0035-012	RG-316 DS	12"	142-0404-011	142-0304-411
415-0035-018	RG-316 DS	18"	142-0404-011	142-0304-411
415-0035-024	RG-316 DS	24"	142-0404-011	142-0304-411
415-0035-036	RG-316 DS	36"	142-0404-011	142-0304-411

Part No.	Cable Type	Cable Length	Connector A	Connector B
415-0035-048	RG-316DS	48"	142-0404-011	142-0304-411
415-0040-012	RG-58	12"	142-0407-011	142-0307-411
415-0040-024	RG-58	24"	142-0407-011	142-0307-411
415-0040-036	RG-58	36"	142-0407-011	142-0307-411
415-0040-048	RG-58	48"	142-0407-011	142-0307-411
415-0040-060	RG-58	60"	142-0407-011	142-0307-411
415-0045-012	RG-142	12"	142-0408-011	142-0308-411
415-0045-024	RG-142	24"	142-0408-011	142-0308-411
415-0045-036	RG-142	36"	142-0408-011	142-0308-411
415-0045-048	RG-142	48"	142-0408-011	142-0308-411
415-0045-060	RG-142	60"	142-0408-011	142-0308-411



SMA Right Angle Plug to SMA Straight Bulkhead Jack

Part No.	Cable Type	Cable Length	Connector A	Connector B
415-0074-006	RG-316	6"	142-0403-101	142-0303-411
415-0074-012	RG-316	12"	142-0403-101	142-0303-411
415-0074-024	RG-316	24"	142-0403-101	142-0303-411
415-0074-036	RG-316	36"	142-0403-101	142-0303-411
415-0074-048	RG-316	48"	142-0403-101	142-0303-411
415-0064-006	RG-316DS	6"	142-0404-101	142-0304-411
415-0064-012	RG-316DS	12"	142-0404-101	142-0304-411
415-0064-024	RG-316DS	24"	142-0404-101	142-0304-411

Part No.	Cable Type	Cable Length	Connector A	Connector B
415-0064-036	RG-316DS	36"	142-0404-101	142-0304-411
415-0064-048	RG-316DS	48"	142-0404-101	142-0304-411
415-0075-006	RG-142	6"	142-0406-101	142-0306-411
415-0075-012	RG-142	12"	142-0406-101	142-0306-411
415-0075-024	RG-142	24"	142-0406-101	142-0306-411
415-0075-036	RG-142	36"	142-0406-101	142-0306-411
415-0075-048	RG-142	48"	142-0406-101	142-0306-411

Straight SMA Quick-Connect Plug to Straight SMA Quick-Connect Plug



Part No.	Cable Type	Cable Length	Connector A	Connector B
415-0065-006	RG-316	6"	142-1403-001	142-1403-001
415-0065-012	RG-316	12"	142-1403-001	142-1403-001
415-0065-018	RG-316	18"	142-1403-001	142-1403-001
415-0065-024	RG-316	24"	142-1403-001	142-1403-001
415-0065-036	RG-316	36"	142-1403-001	142-1403-001
415-0065-048	RG-316	48"	142-1403-001	142-1403-001

Part No.	Cable Type	Cable Length	Connector A	Connector B
415-0076-012	RG-316DS	12"	142-1404-001	142-1404-001
415-0076-024	RG-316DS	24"	142-1404-001	142-1404-001
415-0076-036	RG-316DS	36"	142-1404-001	142-1404-001
415-0077-012	RG-142	12"	142-1408-001	142-1408-001
415-0077-024	RG-142	24"	142-1408-001	142-1408-001
415-0077-036	RG-142	36"	142-1408-001	142-1408-001

Straight SMA Quick-Connect Plug to Straight SMA Plug



Part No.	Cable Type	Cable Length	Connector A	Connector B
415-0078-012	RG-316DS	12"	142-1404-001	142-0404-011
415-0078-024	RG-316DS	24"	142-1404-001	142-0404-011
415-0078-036	RG-316DS	36"	142-1404-001	142-0404-011

Part No.	Cable Type	Cable Length	Connector A	Connector B
415-0079-012	RG-142	12"	142-1408-001	142-0408-011
415-0079-024	RG-142	24"	142-1408-001	142-0408-011
415-0079-036	RG-142	36"	142-1408-001	142-0408-011

SMB Straight Plug to SMB Straight Plug



Part No.	Cable Type	Cable Length	Connector A	Connector B
413-0003-000	RG-316	6"	131-1403-001	131-1403-001
415-0003-012	RG-316	12"	131-1403-001	131-1403-001
415-0003-018	RG-316	18"	131-1403-001	131-1403-001

Part No.	Cable Type	Cable Length	Connector A	Connector B
413-0003-024	RG-316	24"	131-1403-001	131-1403-001
415-0003-030	RG-316	30"	131-1403-001	131-1403-001
415-0003-036	RG-316	36"	131-1403-001	131-1403-001

SMB Mini-75 Ohm Straight Plug to SMB Mini-75 Ohm Right Angle Plug



Part No.	Cable Type	Cable Length	Connector A	Connector B
415-0009-006	RG -179	6"	131-8403-111	131-8403-111
415-0009-012	RG -179	12"	131-8403-111	131-8403-111
415-0009-018	RG -179	18"	131-8403-111	131-8403-111
415-0009-024	RG -179	24"	131-8403-111	131-8403-111
415-0009-030	RG -179	30"	131-8403-111	131-8403-111
415-0009-036	RG -179	36"	131-8403-111	131-8403-111
415-0011-006	RG-179 DS	6"	131-8404-111	131-8404-111
415-0011-012	RG-179 DS	12"	131-8404-111	131-8404-111
415-0011-018	RG-179 DS	18"	131-8404-111	131-8404-111

Part No.	Cable Type	Cable Length	Connector A	Connector B
415-0011-024	RG-179 DS	24"	131-8404-111	131-8404-111
415-0011-030	RG-179 DS	30"	131-8404-111	131-8404-111
415-0011-036	RG-179 DS	36"	131-8404-111	131-8404-111
415-0013-006	Belden 735A	6"	131-8445-101	131-8445-101
415-0013-012	Belden 735A	12"	131-8445-101	131-8445-101
415-0013-018	Belden 735A	18"	131-8445-101	131-8445-101
415-0013-024	Belden 735A	24"	131-8445-101	131-8445-101
415-0013-030	Belden 735A	30"	131-8445-101	131-8445-101
415-0013-036	Belden 735A	36"	131-8445-101	131-8445-101

N Straight Plug to N Straight Plug



Part No.	Cable Type	Cable Length	Connector A	Connector B
415-0058-012	RG -58	12"	CPN -1	CPN -1
415-0058-024	RG -58	24"	CPN -1	CPN -1
415-0058-036	RG -58	36"	CPN -1	CPN -1
415-0058-048	RG -58	48"	CPN -1	CPN -1
415-0058-060	RG -58	60"	CPN -1	CPN -1
415-0060-012	RG -142	12"	CPN -142T	CPN -142T
415-0060-024	RG -142	24"	CPN -142T	CPN -142T
415-0060-036	RG -142	36"	CPN -142T	CPN -142T
415-0060-048	RG -142	48"	CPN -142T	CPN -142T
415-0060-060	RG -142	60"	CPN -142T	CPN -142T

Part No.	Cable Type	Cable Length	Connector A	Connector B
415-0062-012	RG-8	12"	CPN -8	CPN -8
415-0062-024	RG-8	24"	CPN -8	CPN -8
415-0062-036	RG-8	36"	CPN -8	CPN -8
415-0062-048	RG-8	48"	CPN -8	CPN -8
415-0062-060	RG-8	60"	CPN -8	CPN -8
415-0063-012	RG -213	12"	CPN -8	CPN -8
415-0063-024	RG -213	24"	CPN -8	CPN -8
415-0063-036	RG -213	36"	CPN -8	CPN -8
415-0063-048	RG -213	48"	CPN -8	CPN -8
415-0063-060	RG -213	60"	CPN -8	CPN -8

BNC Straight Plug to BNC Straight Plug



Part No.	Cable Type	Cable Length	Connector A	Connector B
415-0054-012	RG -58	12"	CPMC-88-1	CPMC-88-1
415-0054-024	RG -58	24"	CPMC-88-1	CPMC-88-1
415-0054-036	RG -58	36"	CPMC-88-1	CPMC-88-1
415-0054-048	RG -58	48"	CPMC-88-1	CPMC-88-1
415-0054-060	RG -58	60"	CPMC-88-1	CPMC-88-1
415-0057-012	RG-59	12"	CPMC-88-2	CPMC-88-2
415-0057-024	RG-59	24"	CPMC-88-2	CPMC-88-2
415-0057-036	RG-59	36"	CPMC-88-2	CPMC-88-2
415-0057-048	RG-59	48"	CPMC-88-2	CPMC-88-2

Part No.	Cable Type	Cable Length	Connector A	Connector B
415-0056-012+	Belden 8218	12"	CPMC-88-18	CPMC-88-18
415-0056-024+	Belden 8218	24"	CPMC-88-18	CPMC-88-18
415-0056-036+	Belden 8218	36"	CPMC-88-18	CPMC-88-18
415-0056-048+	Belden 8218	48"	CPMC-88-18	CPMC-88-18
415-0056-060+	Belden 8218	60"	CPMC-88-18	CPMC-88-18

+ with Heat Shrink



kwiQMate™ Straight to Straight

Part No.	Cable Type	Cable Length	Connector A	Connector B
415-0162-006	RG-316DS	6"	146-0404-007	146-0404-007
415-0162-012	RG-316DS	12"	146-0404-007	146-0404-007
415-0162-024	RG-316DS	24"	146-0404-007	146-0404-007
415-0162-036	RG-316DS	36"	146-0404-007	146-0404-007
415-0162-048	RG-316DS	48"	146-0404-007	146-0404-007

Part No.	Cable Type	Cable Length	Connector A	Connector B
415-0163-006	RG-316	6"	146-0403-007	146-0403-007
415-0163-012	RG-316	12"	146-0403-007	146-0403-007
415-0163-024	RG-316	24"	146-0403-007	146-0403-007
415-0163-036	RG-316	36"	146-0403-007	146-0403-007
415-0163-048	RG-316	48"	146-0403-007	146-0403-007



kwiQMate™ Straight to Right Angle

Part No.	Cable Type	Cable Length	Connector A	Connector B
415-0171-006	RG-316DS	6"	146-0404-007	146-0404-107
415-0171-012	RG-316DS	12"	146-0404-007	146-0404-107
415-0171-024	RG-316DS	24"	146-0404-007	146-0404-107
415-0171-036	RG-316DS	36"	146-0404-007	146-0404-107
415-0171-048	RG-316DS	48"	146-0404-007	146-0404-107

Part No.	Cable Type	Cable Length	Connector A	Connector B
415-0172-006	RG-316	6"	146-0403-007	146-0403-107
415-0172-012	RG-316	12"	146-0403-007	146-0403-107
415-0172-024	RG-316	24"	146-0403-007	146-0403-107
415-0172-036	RG-316	36"	146-0403-007	146-0403-107
415-0172-048	RG-316	48"	146-0403-007	146-0403-107



kwiQMate™ Right Angle to Right Angle

Part No.	Cable Type	Cable Length	Connector A	Connector B
415-0174-006	RG-316DS	6"	146-0404-107	146-0404-107
415-0174-012	RG-316DS	12"	146-0404-107	146-0404-107
415-0174-024	RG-316DS	24"	146-0404-107	146-0404-107
415-0174-036	RG-316DS	36"	146-0404-107	146-0404-107
415-0174-048	RG-316DS	48"	146-0404-107	146-0404-107

Part No.	Cable Type	Cable Length	Connector A	Connector B
415-0175-006	RG-316	6"	146-0403-107	146-0403-107
415-0175-012	RG-316	12"	146-0403-107	146-0403-107
415-0175-024	RG-316	24"	146-0403-107	146-0403-107
415-0175-036	RG-316	36"	146-0403-107	146-0403-107
415-0175-048	RG-316	48"	146-0403-107	146-0403-107



kwiQMate™ Straight to SMA Straight

Part No.	Cable Type	Cable Length	Connector A	Connector B
415-0165-006	RG-316DS	6"	146-0404-007	142-0404-016
415-0165-012	RG-316DS	12"	146-0404-007	142-0404-016
415-0165-024	RG-316DS	24"	146-0404-007	142-0404-016
415-0165-036	RG-316DS	36"	146-0404-007	142-0404-016
415-0165-048	RG-316DS	48"	146-0404-007	142-0404-016

Part No.	Cable Type	Cable Length	Connector A	Connector B
415-0166-006	RG-316	6"	146-0403-007	142-0403-016
415-0166-012	RG-316	12"	146-0403-007	142-0403-016
415-0166-024	RG-316	24"	146-0403-007	142-0403-016
415-0166-036	RG-316	36"	146-0403-007	142-0403-016
415-0166-048	RG-316	48"	146-0403-007	142-0403-016

Specifications

- Impedance:** 50 Ω (Nominal)
- Temperature Range:** -40°C to +90°C
- Frequency Rating:** 0-6 GHz
- VSWR:** 1.30 max (0-6 GHz)
- Contact Resistance:** 20 m Ω max. (Center)
20 m Ω max. (Outer, for plug)
10 m Ω max. (Outer, for receptacle)
- Withstanding Voltage:** 200 V AC
- Insulation Resistance:** 500 M Ω min.
- Durability:** 30 cycles
- Holding Force (min.):** 0.15 N (Female contact)

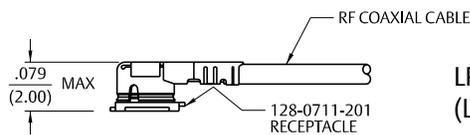

LP Plug
(Low Profile Plug)

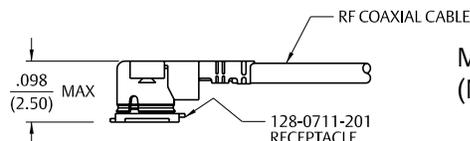

MP Plug
(Medium Profile Plug)

Low Profile UMC Right Angle Cable Plug to UMC Right Angle Cable Plug



Part No.	Teflon Coaxial Cable O.D.	Cable Length	Connector A	Plug Mated Height	Connector B
415-0084-050	0.81 mm	50 mm	UMC LP PLUG	2.0 mm	UMC LP PLUG
415-0084-100	0.81 mm	100 mm	UMC LP PLUG	2.0 mm	UMC LP PLUG
415-0084-150	0.81 mm	150 mm	UMC LP PLUG	2.0 mm	UMC LP PLUG
415-0084-200	0.81 mm	200 mm	UMC LP PLUG	2.0 mm	UMC LP PLUG
415-0084-250	0.81 mm	250 mm	UMC LP PLUG	2.0 mm	UMC LP PLUG
415-0084-300	0.81 mm	300 mm	UMC LP PLUG	2.0 mm	UMC LP PLUG
415-0084-500	0.81 mm	500 mm	UMC LP PLUG	2.0 mm	UMC LP PLUG

Medium Profile UMC Right Angle Cable Plug to UMC Right Angle Cable Plug



Part No.	Teflon Coaxial Cable O.D.	Cable Length	Connector A	Plug Mated Height	Connector B
415-0085-050	0.81 mm	50 mm	UMC MP PLUG	2.5 mm	UMC MP PLUG
415-0085-100	0.81 mm	100 mm	UMC MP PLUG	2.5 mm	UMC MP PLUG
415-0085-150	0.81 mm	150 mm	UMC MP PLUG	2.5 mm	UMC MP PLUG
415-0085-200	0.81 mm	200 mm	UMC MP PLUG	2.5 mm	UMC MP PLUG
415-0085-250	0.81 mm	250 mm	UMC MP PLUG	2.5 mm	UMC MP PLUG
415-0085-300	0.81 mm	300 mm	UMC MP PLUG	2.5 mm	UMC MP PLUG
415-0085-500	0.81 mm	500 mm	UMC MP PLUG	2.5 mm	UMC MP PLUG
415-0086-050	1.13 mm	50 mm	UMC MP PLUG	2.5 mm	UMC MP PLUG
415-0086-100	1.13 mm	100 mm	UMC MP PLUG	2.5 mm	UMC MP PLUG
415-0086-150	1.13 mm	150 mm	UMC MP PLUG	2.5 mm	UMC MP PLUG
415-0086-200	1.13 mm	200 mm	UMC MP PLUG	2.5 mm	UMC MP PLUG
415-0086-250	1.13 mm	250 mm	UMC MP PLUG	2.5 mm	UMC MP PLUG
415-0086-300	1.13 mm	300 mm	UMC MP PLUG	2.5 mm	UMC MP PLUG
415-0086-500	1.13 mm	500 mm	UMC MP PLUG	2.5 mm	UMC MP PLUG
415-0087-050	1.32 mm	50 mm	UMC MP PLUG	2.5 mm	UMC MP PLUG
415-0087-100	1.32 mm	100 mm	UMC MP PLUG	2.5 mm	UMC MP PLUG
415-0087-150	1.32 mm	150 mm	UMC MP PLUG	2.5 mm	UMC MP PLUG
415-0087-200	1.32 mm	200 mm	UMC MP PLUG	2.5 mm	UMC MP PLUG
415-0087-250	1.32 mm	250 mm	UMC MP PLUG	2.5 mm	UMC MP PLUG
415-0087-300	1.32 mm	300 mm	UMC MP PLUG	2.5 mm	UMC MP PLUG
415-0087-500	1.32 mm	500 mm	UMC MP PLUG	2.5 mm	UMC MP PLUG
415-0088-050	1.37 mm	50 mm	UMC MP PLUG	2.5 mm	UMC MP PLUG
415-0088-100	1.37 mm	100 mm	UMC MP PLUG	2.5 mm	UMC MP PLUG
415-0088-150	1.37 mm	150 mm	UMC MP PLUG	2.5 mm	UMC MP PLUG
415-0088-200	1.37 mm	200 mm	UMC MP PLUG	2.5 mm	UMC MP PLUG
415-0088-250	1.37 mm	250 mm	UMC MP PLUG	2.5 mm	UMC MP PLUG
415-0088-300	1.37 mm	300 mm	UMC MP PLUG	2.5 mm	UMC MP PLUG
415-0088-500	1.37 mm	500 mm	UMC MP PLUG	2.5 mm	UMC MP PLUG

SMA Cable Assembly

UMC Right Angle Cable Plug to SMA Straight Plug



Low Profile



Part No.	Teflon Coaxial Cable O.D.	Cable Length	Connector A	Plug Mated Height	Connector B
415-0089-150	0.81 mm	150 mm	UMC LP PLUG	2.0 mm	SMA STR. PLUG
415-0089-250	0.81 mm	250 mm	UMC LP PLUG	2.0 mm	SMA STR. PLUG

Medium Profile



Part No.	Teflon Coaxial Cable O.D.	Cable Length	Connector A	Plug Mated Height	Connector B
415-0090-150	0.81 mm	150 mm	UMC MP PLUG	2.5 mm	SMA STR. PLUG
415-0090-250	0.81 mm	250 mm	UMC MP PLUG	2.5 mm	SMA STR. PLUG
415-0091-150	1.37 mm	150 mm	UMC MP PLUG	2.5 mm	SMA STR. PLUG
415-0091-250	1.37 mm	250 mm	UMC MP PLUG	2.5 mm	SMA STR. PLUG

UMC Right Angle Cable Plug to SMA Bulkhead Straight Jack



Low Profile



Part No.	Teflon Coaxial Cable O.D.	Cable Length	Connector A	Plug Mated Height	Connector B
415-0095-150	0.81 mm	150 mm	UMC LP PLUG	2.0 mm	SMA STR BKHD. JACK
415-0095-250	0.81 mm	250 mm	UMC LP PLUG	2.0 mm	SMA STR BKHD. JACK

Medium Profile



Part No.	Teflon Coaxial Cable O.D.	Cable Length	Connector A	Plug Mated Height	Connector B
415-0096-150	0.81 mm	150 mm	UMC MP PLUG	2.5 mm	SMA STR BKHD. JACK
415-0096-250	0.81 mm	250 mm	UMC MP PLUG	2.5 mm	SMA STR BKHD. JACK
415-0097-150	1.37 mm	150 mm	UMC MP PLUG	2.5 mm	SMA STR BKHD. JACK
415-0097-250	1.37 mm	250 mm	UMC MP PLUG	2.5 mm	SMA STR BKHD. JACK

Pigtail Cable Assembly

0.81 mm Coaxial Cable

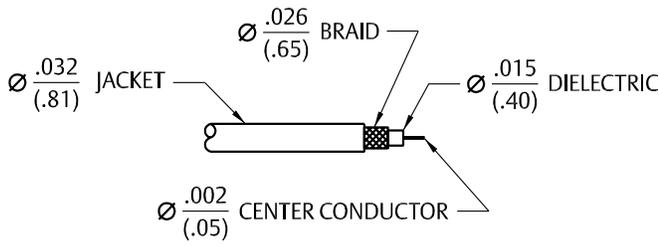

1.32 mm Coaxial Cable

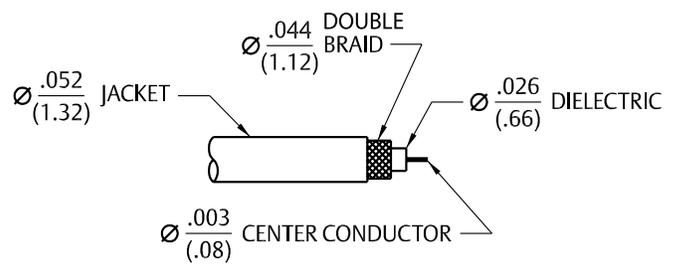

1.13 mm Coaxial Cable

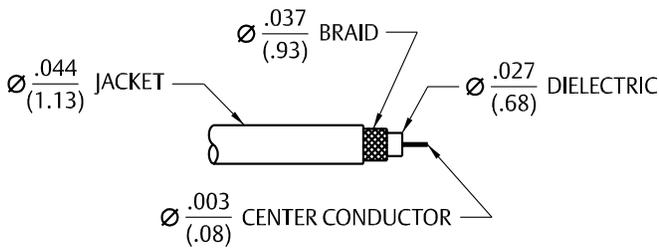

1.37 mm Coaxial Cable

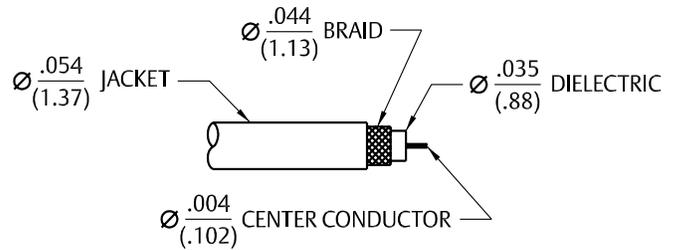

UMC Right Angle Cable Plug to Bare End

Low Profile



Part No.	Teflon Coaxial Cable O.D.	Cable Length	Connector A	Plug Mated Height	Connector B
415-0104-150	0.81 mm	150 mm	UMC LP PLUG	2.0 mm	BARE END
415-0104-250	0.81 mm	250 mm	UMC LP PLUG	2.0 mm	BARE END

Medium Profile



Part No.	Teflon Coaxial Cable O.D.	Cable Length	Connector A	Plug Mated Height	Connector B
415-0105-150	0.81 mm	150 mm	UMC MP PLUG	2.5 mm	BARE END
415-0105-250	0.81 mm	250 mm	UMC MP PLUG	2.5 mm	BARE END
415-0106-150	1.13 mm	150 mm	UMC MP PLUG	2.5 mm	BARE END
415-0106-250	1.13 mm	250 mm	UMC MP PLUG	2.5 mm	BARE END
415-0107-150	1.32 mm	150 mm	UMC MP PLUG	2.5 mm	BARE END
415-0107-250	1.32 mm	250 mm	UMC MP PLUG	2.5 mm	BARE END
415-0108-150	1.37 mm	150 mm	UMC MP PLUG	2.5 mm	BARE END
415-0108-250	1.37 mm	250 mm	UMC MP PLUG	2.5 mm	BARE END

Pigtail Assembly Adapters

SMA Conversion Adapter for Mating UMC Plugs (SMA Plug to UMC Jack)



Part No.
134-1019-361

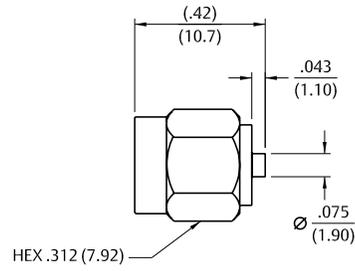

SMA Conversion Adapter for Surface Mt. Jack Receptacle 128-0711-201 (SMA Jack to UMC Plug)



Part No.
134-1019-371

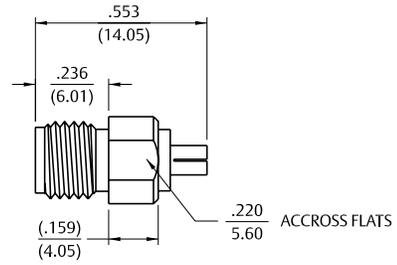

Inspection Tool for Cable Assembly



Part No.
134-1019-381

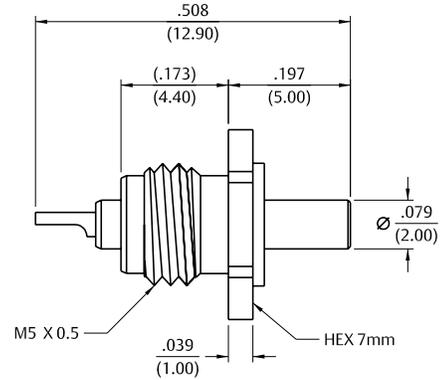

UMC Separation Key



Part No.
128-0000-901

Specifications

Electrical Specifications

Impedance: 50 Ohms
Frequency Range: 12.4 GHz

VSWR: (f = GHz)

	<u>Straight Cable Connectors</u>	<u>Right Angle Cable Connectors</u>
RG-316, RG-316 DS	1.15+.02f	1.15+.03f
Uncabled receptacles	N/A	

Working Voltage: (VRMS max)

	<u>Sea Level</u>	<u>70K Feet</u>
RG-316, RG-316 DS.....	250	65
Uncabled receptacles	335	85

Dielectric Withstanding Voltage: VRMS min (at sea level)

Connectors for RG-316, RG-316 DS	750
Uncabled receptacles	1000

Insulation Resistance: 5000 Megohms min

Contact Resistance: (milliohms max)

	<u>Initial</u>	<u>After Environmental</u>
Center contact (straight cabled connectors and Uncabled receptacles)	3.0	4.0
Center contact (right angle cabled connectors).....	4.0	6.0
Outer Contact (all connectors)	2.0	N/A
Braid to Body (Tri-Alloy plated bodies).....	3.0	N/A
Braid to Body (gold plated bodies)	0.5	N/A

Corona Level: (Volts min at 70,000 feet)

Connectors for RG-316, RG-316 DS	190
Uncabled receptacles	250

Insertion Loss: (dB max)

Straight flexible cable connectors	0.06	$f\sqrt{\text{(GHz)}}$, tested at 6 GHz
Right angle flexible cable connectors.....	0.15	$f\sqrt{\text{(GHz)}}$, tested at 6 GHz
Uncabled receptacles		N/A

RF Leakage: (dB max, tested at 3 GHz)

Cable connectors	-80
Uncabled receptacles	N/A

RF High Potential Withstanding Voltage: (Vrms min, tested at 4 and 7 MHz)

Connectors for RG-316, RG-316 DS	500
Uncabled receptacles	670

Mechanical Specifications

Engagement Design:

Durability: 500 cycles min
Engagement/Disengagement Force: 8 lbs max (5 lbs typical)
Coupling Retention Force: 10 lbs min
Contact Retention: 6 lbs min axial force (captivated contacts)
 4 oz-in min torque (uncabled receptacles)

Cable Retention: (min*)

	<u>Axial Force (lbs)</u>	<u>Torque (oz-in)</u>
Connectors for RG-316, RG-316 DS	20	N/A

* Or cable breaking strength, whichever is less

Straight Crimp Type Plug (3-piece) – Captivated Contact



Cable Type	Tri-Alloy Plated
RG-316	146-0403-007
RG-316 DS	146-0404-007

Assembly instructions page 256.

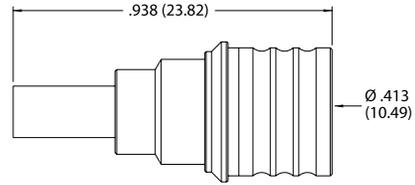

Right Angle Crimp Type Plug (1-piece body) – Captivated Contact



Cable Type	Tri-Alloy Plated
RG-316	146-0403-107
RG-316 DS	146-0404-107

Assembly instructions page 255.

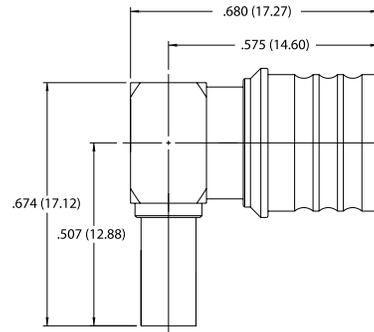

Straight Jack Receptacle



Gold Plated
146-0701-201

Mounting hole layout figure 2 page 194.

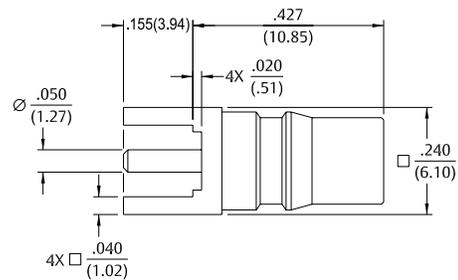

Right Angle Jack Receptacle



Gold Plated
146-0701-301

Mounting hole layout figure 2 page 194.

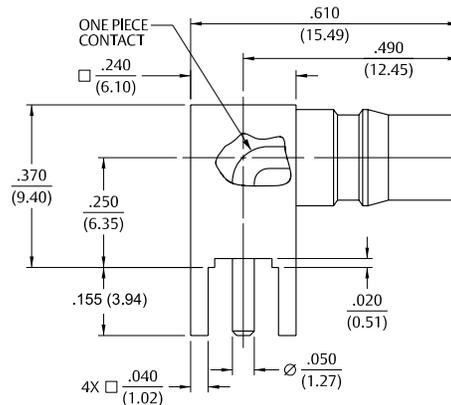

Coaxial Connector Assembly Tools

Hand Crimp Tool

Precision Astro Tool hand crimping tool makes cable assembly fast and easy. Crimping tool features interchangeable steel dies. Ratchet action of tool controls crimping operation for precise uniform ferrule crimps.



Connector Type	Cable Type	Preferred Die Set	Crimp Dimensions
MCX SMA SMB SMC	RG-178/U RG-196/U	141-0000-901	Hex = .105 (2.67) Width = .325 (8.26)
MCX SMA SMB SMC 75 Ohm SMB	RG-161/U, RG-174/U RG-179/U, RG-187/U RG-188/U, RG-316/U LMR-100	141-0000-902	Hex = .128 (3.25) Width = .400 (10.16)
	RG-188/U, RG316/U RG-179/U, RG-187/U BELDEN 735A	141-0000-905	Hex = .151 (3.83) Width = .400 (10.16)
MCX SMA SMB	RG-58/U RG-141/U RG-303/U RG-55/U RG-142/U RG-223/U RG-400/U LMR-195 LMR-200	141-0000-903	Hex = .213 (5.41) Width = .375 (9.52)
SMA 75 Ohm SMB	LMR-240, RG-59	141-0000-925	Hex = .255 (6.48) Width = .400 (10.16)
N Type	RG-316/U, 316 DS	141-0000-927	Hex = .160 (4.06) Width = .400 (10.16)

* Economy Hand Crimp Tool also available with four hex sizes in one tool page 187.

Ordering Information for Crimp Tool

Part No.	Description	ASTRO Tool Part No.
144-0000-900	Frame Only	620175
141-0000-901	Single Hex Die	620932
141-0000-902	Single Hex Die	620419
141-0000-903	Single Hex Die	620676
141-0000-905	Single Hex Die	630055
141-0000-925	Single Hex Die	620938
141-0000-927	Single Hex Die	620297

Ordering Information for Crimp Tool

Connector Type	Preferred Die Ste	Crimp Style
SMB Cross Hole Style Body 50 Ohm Only	141-0000-911	Double Diamond
Mini 75 Ohm SMB, MCX 75 Ohm Cross Hole Style Body	141-0000-924	Double Diamond

Coaxial Connector Assembly Tools

MCX Right Angle Plug Assembly Tool

This quick and easy to use tool will press the end cap onto standard right angle MCX plug connectors. Simply insert the connector and cap into the staking nest and a light squeeze of the handles will swage the cap into place. The jaw tips are shaped to grip a right angle MCX plug body for insertion or disengagement to a mating receptacle. The jaws are hardened steel and the handles are cushioned to minimize stress to the user. For use with all cable groups except RG-58.



Part No.

141-0000-908

SMA Knurl Mount Assembly Tool

The Knurl Mount SMA Spark Plug Connectors can be pressed into position using this thread-on fixture designed for low volume lab use.



Part No.

140-0000-954

SMB Plug Removal Tool

Reaches in to disengage SMB connectors in high density packaging applications.



Part No.

140-0000-956

We Have What You Are Looking For ... and If We Don't, We'll Design and Manufacture It!!!

Emerson Network Power Connectivity Solutions prides itself in meeting our customers' needs by providing them with customized solutions. We have configured our technical staff and equipped our model shop and QA lab to meet the quick-turn demands of new product development. Prototypes, samples, and short-run quantities are delivered expediently and to print. Your new product development life cycle will be greatly enhanced with us as a partner on your design team.

We have an extensive log of special variations of MMCX, MCX, 75 Ohm MCX, SMK, SMA, SMP, SMB, Mini-75 Ohm SMB, SMC, BNC, TNC and N connectors. Special cable sizes, cable assemblies, PC board terminations, adapters, antenna connectors, multi-packs, calibration terminations and hardware products give us a large pool of design experience to assist you with custom development. See page 259 for more information on our custom hardware products.

Our sales representatives will review your product application and initiate the quotation process, and our sales and engineering staff will assist you in defining the performance and cost parameters required by your end product. Providing details such as dimensional limitations, frequency, and VSWR performance to our field sales representative will speed the process.

After you have chosen us as your supplier, we can provide samples and a short run quantity prior to production of your custom product. We look forward to providing your special electronic components in the future.

We do it all...

Virtually any RF coaxial connector or RF cable assembly from the engineering, prototyping and tooling stages, to complete production and testing.



N Jack 75 Ohm to MCX Plug
75 Ohm Assembly, Adapter



Ganged MCX Right-Angle
Board Mount



SMB Vertical
PC Plug

Cable Information

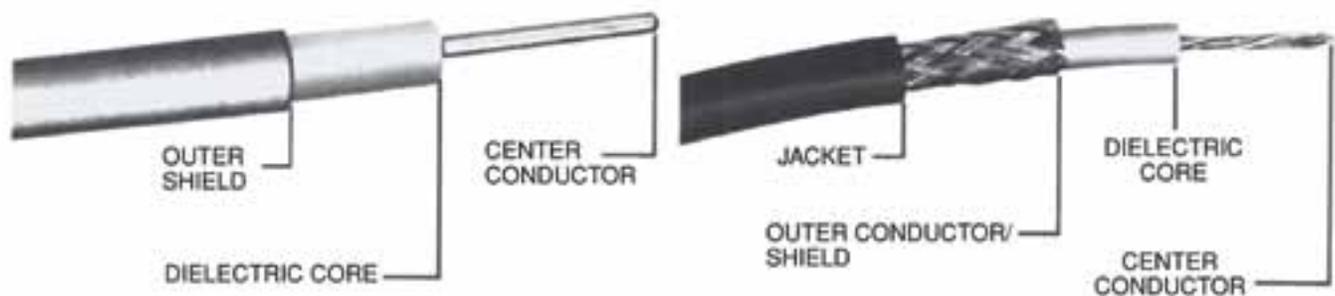

Semi-Rigid Cable Dimensions

Cable	Center Conductor O.D.	O.D. Dielectric	O.D. Shield	Impedance
RG-405/U	.0201 (0.51)	.0658 (1.67)	.086 (2.18)	50
RG-402/U	.0359 (0.91)	.1175 (2.98)	.141 (3.58)	50

RF Flexible Cable Dimension

Cable	Center Conductor	O.D. Dielectric	O.D. Shield	O.D. Jacket	Impedance
.047 dia.	.007 (0.19)	.020 (0.52)	.035 (0.90)	.047 (1.20)	50
RG-178B/U	.012 (.030)	.034 (0.86)	.054 (1.37)	.071 (1.80)	50
RG-196A/U	.012 (.030)	.034 (0.86)	.054 (1.37)	.071 (1.80)	50
RG-174/U	.019 (0.48)	.060 (1.52)	.080 (2.03)	.110 (2.79)	50
RG-179B/U	.012 (.030)	.063 (1.60)	.084 (2.13)	.110 (2.79)	75
RG-187A/U	.012 (.030)	.060 (1.52)	.084 (2.13)	.110 (2.79)	75
RG-188A/U	.020 (0.51)	.060 (1.52)	.081 (2.06)	.110 (2.79)	50
RG-316/U	.020 (0.51)	.060 (1.52)	.081 (2.06)	.110 (2.79)	50
RG-316 DS	.020 (0.51)	.060 (1.52)	(DS) .100 (2.54)	.120 (3.05)	50
RG-179 DS	.012 (.030)	.063 (1.60)	(DS) .103 (2.62)	.120 (3.05)	75
RG-187 DS	.012 (.030)	.060 (1.52)	(DS) .100 (2.54)	.120 (3.05)	75
RG-188 DS	.020 (0.51)	.060 (1.52)	(DS) .100 (2.54)	.120 (3.05)	50
RG-141A/U	.039 (0.99)	.116 (2.95)	.146 (3.71)	.190 (4.83)	50
RG-303/U	.039 (0.96)	.116 (2.95)	.146 (3.71)	.190 (4.83)	50
RG-400/U	.038 (0.96)	.116 (2.95)	(DS) .171 (4.34)	.195 (4.85)	50
RG-142B/U	.039 (0.99)	.116 (2.95)	(DS) .171 (4.34)	.195 (4.95)	50
RG-58C/U	.038 (0.96)	.116 (2.95)	.150 (3.81)	.195 (4.95)	50
RG-55B/U	.032 (0.81)	.116 (2.95)	(DS) .176 (4.47)	.206 (5.23)	53.5
RG-223/U	.032 (0.81)	.116 (2.95)	(DS) .176 (4.47)	.206 (5.23)	53.5
LMR-100	.022 (.056)	.062 (1.57)	.085 (2.16)	.105 (2.67)	50
LMR-195	.037 (0.94)	.110 (2.79)	.139 (3.53)	.195 (4.95)	50
LMR-200	.044 (1.12)	.116 (2.95)	.144 (3.66)	.195 (4.95)	50
LMR-240	.056 (1.42)	.150 (3.81)	.178 (4.52)	.240 (6.10)	50
735A	.016 (0.41)	.077 (1.96)	.101 (2.57)	.128 (3.25)	75
RG-59	.0226 (0.57)	.146 (3.71)	.191 (4.85)	.242 (6.15)	75

Recommended Mounting Hole Dimensions

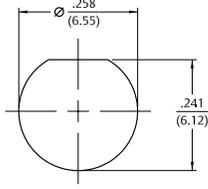

1

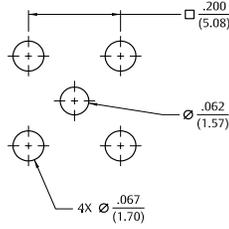

2

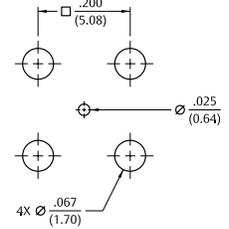

3

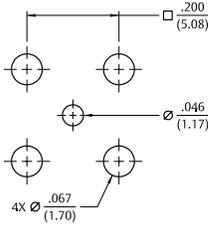

4

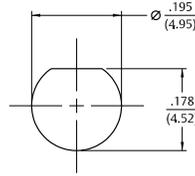

5

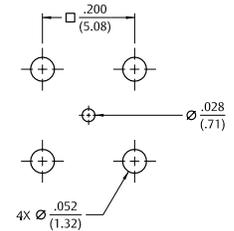

6

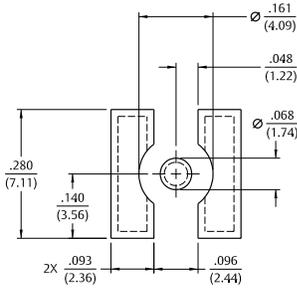

7

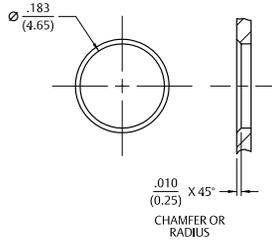

8

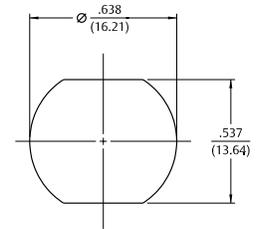

9

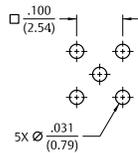

10

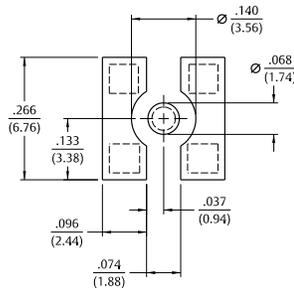

11

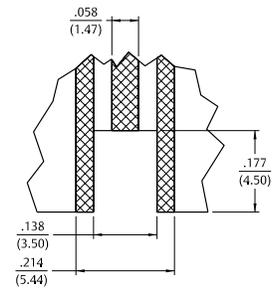

12

Reference

131-1402-101.....	238	131-6404-006.....	237	133-3403-101.....	210	135-3436-001.....	202
131-1402-116.....	238	131-6404-101.....	238	133-3403-106.....	210	135-3436-101.....	200
131-1403-001.....	237	131-6404-106.....	238	133-3404-001.....	207	135-3693-101.....	198
131-1403-016.....	237	131-6433-001.....	237	133-3404-006.....	207	135-9402-001.....	205
131-1403-101.....	238	131-6433-006.....	237	133-3404-101.....	210	135-9402-111.....	199
131-1403-116.....	238	131-6433-101.....	238	133-3404-106.....	210	135-9403-001.....	204
131-1404-001.....	237	131-6433-106.....	238	133-3407-101.....	210	135-9403-101.....	199
131-1404-016.....	237	131-6593-401.....	233	133-3407-106.....	210	135-9404-001.....	204
131-1404-101.....	238	131-6593-406.....	233	133-3433-001.....	207	135-9436-001.....	205
131-1404-116.....	238	131-8303-401.....	237	133-3433-006.....	207	135-9436-101.....	200
131-1693-101.....	234	131-8303-406.....	237	133-3433-101.....	210	138-4303-407.....	248
131-1693-116.....	234	131-8304-401.....	237	133-3433-106.....	210	138-4304-407.....	248
131-3302-001.....	237	131-8304-406.....	237	133-3693-001.....	206	138-4307-407.....	251
131-3302-006.....	237	131-8403-001.....	237	133-3693-006.....	206	138-4308-407.....	251
131-3303-001.....	237	131-8403-006.....	237	133-3693-101.....	206	138-4316-407.....	251
131-3303-006.....	237	131-8403-011.....	237	133-3693-106.....	206	138-4318-407.....	251
131-3303-401.....	237	131-8403-016.....	237	133-5302-401.....	207	138-4349-407.....	251
131-3303-406.....	237	131-8403-101.....	238	133-5302-406.....	207	138-4403-007.....	242
131-3303-501.....	238	131-8403-106.....	238	133-5303-401.....	207	138-4403-107.....	244
131-3303-506.....	238	131-8403-111.....	238	133-5303-406.....	207	138-4404-007.....	242
131-3304-401.....	237	131-8403-116.....	238	133-5304-401.....	207	138-4404-107.....	244
131-3304-406.....	237	131-8404-001.....	237	133-5304-406.....	207	138-4407-007.....	243
131-3304-501.....	238	131-8404-006.....	237	133-5402-001.....	207	138-4407-107.....	244
131-3304-506.....	238	131-8404-011.....	237	133-5402-006.....	207	138-4408-007.....	243
131-3402-001.....	237	131-8404-016.....	237	133-5402-101.....	210	138-4408-107.....	244
131-3402-016.....	237	131-8404-101.....	238	133-5402-106.....	210	138-4416-007.....	243
131-3402-101.....	238	131-8404-106.....	238	133-5403-001.....	207	138-4416-107.....	245
131-3402-116.....	238	131-8404-111.....	238	133-5403-006.....	207	138-4418-007.....	243
131-3403-001.....	237	131-8404-116.....	238	133-5403-101.....	210	138-4418-107.....	245
131-3403-016.....	237	131-8409-001.....	237	133-5403-106.....	210	138-4449-007.....	243
131-3403-021.....	232	131-8409-006.....	237	133-5404-001.....	207	138-4593-401.....	250
131-3403-026.....	232	131-8409-101.....	238	133-5404-006.....	207	138-4594-401.....	250
131-3403-101.....	238	131-8409-106.....	238	133-5404-101.....	210	138-4596-401.....	250
131-3403-116.....	238	131-8433-001.....	232	133-5404-106.....	210	138-4693-001.....	246
131-3403-401.....	237	131-8433-006.....	232	133-8333-001.....	209	138-4693-011.....	247
131-3403-406.....	237	131-8434-001.....	232	133-8333-401.....	209	138-4694-001.....	246
131-3404-001.....	237	131-8434-006.....	232	133-8334-001.....	209	138-4694-011.....	247
131-3404-016.....	237	131-8445-001.....	237	133-8334-401.....	209	138-4696-001.....	246
131-3404-021.....	232	131-8445-006.....	237	133-8433-001.....	209	138-4696-011.....	247
131-3404-026.....	232	131-8445-011.....	232	133-8433-101.....	211	138-9408-007.....	240
131-3404-101.....	238	131-8445-016.....	232	133-8434-001.....	209	138-9449-007.....	240
131-3404-116.....	238	131-8445-101.....	238	133-8434-101.....	211	141-0303-412.....	219
131-3404-401.....	237	131-8445-106.....	238	133-8445-001.....	209	141-0304-412.....	219
131-3404-406.....	237	131-9403-001.....	235	133-8445-101.....	211	141-0307-412.....	219
131-3407-001.....	237	131-9403-021.....	232	133-9402-101.....	208	141-0308-412.....	219
131-3407-006.....	237	131-9403-101.....	236	133-9403-001.....	207	141-0403-012.....	219
131-3407-011.....	232	131-9403-116.....	236	133-9403-101.....	208	141-0403-102.....	224
131-3407-016.....	232	131-9404-001.....	235	133-9403-104.....	208	141-0404-012.....	219
131-3407-101.....	238	131-9404-021.....	232	133-9404-001.....	207	141-0404-112.....	224
131-3407-106.....	238	131-9404-101.....	236	133-9404-101.....	208	141-0407-012.....	219
131-3593-401.....	233	131-9404-116.....	236	134-0303-406.....	239	141-0407-102.....	224
131-3593-406.....	233	133-3302-001.....	207	134-0304-406.....	239	141-0408-012.....	219
131-3693-001.....	233	133-3302-006.....	207	134-0307-406.....	239	141-0408-102.....	224
131-3693-016.....	233	133-3302-401.....	207	134-0308-406.....	239	141-0593-001.....	214
131-3693-101.....	234	133-3302-406.....	207	135-3302-001.....	205	141-0593-401.....	214
131-3693-116.....	234	133-3303-001.....	207	135-3302-401.....	205	141-0593-421.....	222
131-3694-401.....	233	133-3303-006.....	207	135-3303-001.....	204	141-0594-001.....	214
131-3694-406.....	233	133-3303-401.....	207	135-3304-001.....	204	141-0594-401.....	214
131-6303-401.....	237	133-3303-406.....	207	135-3333-001.....	204	141-0594-421.....	222
131-6303-406.....	237	133-3304-001.....	207	135-3336-001.....	205	141-0693-002.....	214
131-6304-401.....	237	133-3304-006.....	207	135-3336-401.....	205	141-0693-062.....	222
131-6304-406.....	237	133-3304-401.....	207	135-3402-001.....	202	141-0694-002.....	214
131-6333-401.....	237	133-3304-406.....	207	135-3402-101.....	200	141-0694-012.....	214
131-6333-406.....	237	133-3402-001.....	207	135-3402-111.....	201	141-0694-062.....	222
131-6403-001.....	237	133-3402-006.....	207	135-3403-001.....	203	142-0002-221.....	252
131-6403-006.....	237	133-3402-101.....	210	135-3403-101.....	201	142-0002-226.....	252
131-6403-101.....	238	133-3402-106.....	210	135-3404-001.....	203	142-0002-811.....	253
131-6403-106.....	238	133-3403-001.....	207	135-3404-101.....	201	142-0002-821.....	254
131-6404-001.....	237	133-3403-006.....	207	135-3433-001.....	203	142-0003-201.....	252

MMCX Right Angle Plug for .086 (2.18) Semi-Rigid Cable

1. Identify piece parts. (2 piece parts)
2. Strip cable to dimensions shown. Do not nick center conductor.
3. Insert cable into body making certain that jacket bottoms on the connector body. Fixture cable and assembly to prevent movement during soldering.
4. Solder center conductor to contact as shown. Use a minimum amount of solder for a good joint.
5. Solder body to cable as shown. Use a minimum amount of heat to minimize cable insulation movement.
6. Press end cap into body access port using .156 (3.96) diameter flat punch or Johnson assembly tool 141-0000-910.

Cable Group	Part No.
RG-405/U (.086 Semi-Rigid)	135-3693-101

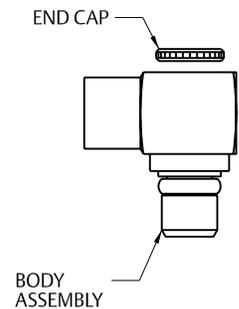
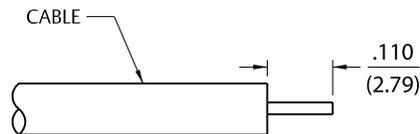
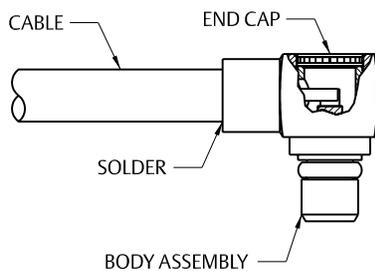
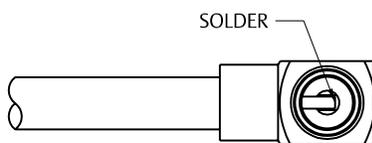

MMCX Right Angle Plug for .047 (1.20) Diameter and RG-178 Size Flexible Cable with Crimp Insert

1. Identify piece parts. (3 piece parts)
2. Strip cable jacket to dimensions shown. Do not nick braid or center conductor during strip operations.
3. Slide crimp insert over braid and against jacket. Fold braid around crimp insert as shown. Strip cable dielectric to dimension shown. Tin center conductor.
4. Slide body assembly over cable and crimp insert, then seat firmly so cable dielectric butts against contact as shown. Crimp body using recommended crimp hex. Maintain forward pressure on cable while crimping.
5. Solder contact to center conductor through rear access port. Use a minimum amount of solder for a full fillet joint.
6. Press end cap into access port using .156 (3.96) diameter flat punch or Johnson assembly tool 141-0000-910.

Cable Group	Part No.	"L"	Crimp Hex
.047 Flexible	135-3436-101	.140 (3.56)	.105 (2.67)
RG-178/U, 196	135-3402-101	.188 (4.78)	.105 (2.67)
.047 Flexible	135-9436-101	.140 (3.56)	.105 (2.67)

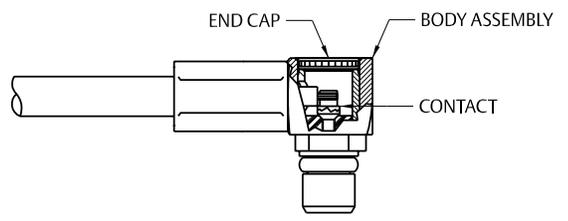
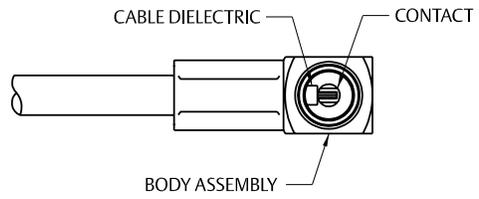
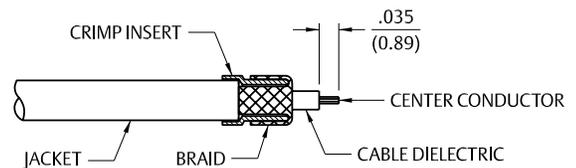
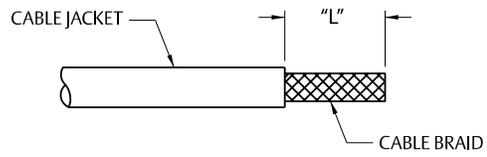
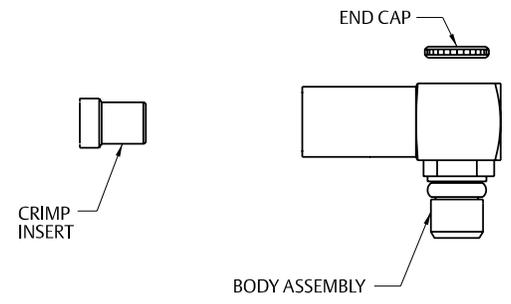

MMCX Straight Plug for .047 (1.19) Diameter and RG-178 Size Flexible Cable

1. Identify piece parts. (3 piece parts)
2. Strip cable jacket to dimensions shown. Do not nick braid or center conductor during strip operations.
3. Slide crimp insert over braid and against jacket. Fold braid around crimp insert as shown. Strip dielectric to dimension shown. Tin center conductor if contact is to be soldered attached. Do not tin center conductor if contact is to be crimp attached.
4. Assemble contact assembly onto cable as shown.

Solder attachment: Solder contact to center conductor. Care should be taken that excess solder is not applied.

Crimp attachment: Crimp contact to center conductor using Johnson hand tool 140-0000-952 and die set 140-000-953. Crimp location should be centered between and of contact and cross-hole. Crimp attachment to solid center conductor cables is not recommended.
5. Slide body assembly over contact and crimp insert, then seat firmly as shown. Crimp body using recommended crimp die hex. Maintain forward pressure on cable while crimping.

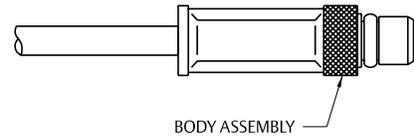
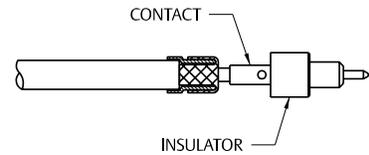
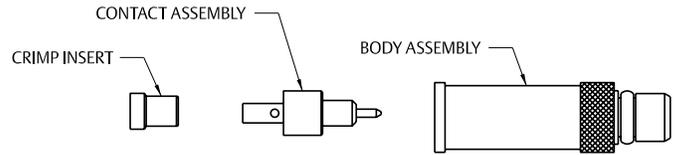
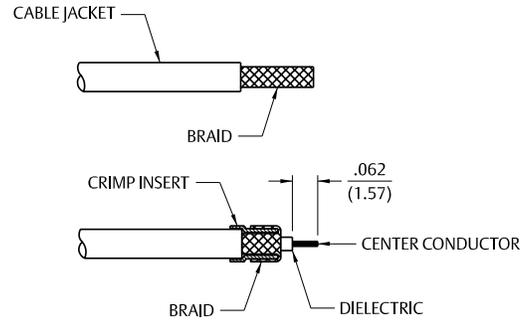

Cable Group	Part No.	Strip Length	Crimp Hex
.047 Flexible	135-3436-001	.135 (3.43)	.105 (2.67) x .250 (6.35) W
RG-178/U, 196	135-3402-001	.184 (4.67)	.105 (2.67) x .250 (6.35) W

MMCX Straight Jack for RG-316, RG-316 DS and RG-179 Size Flexible Cable

1. Identify connector parts. (3 piece parts)
2. Strip cable jacket to dimensions shown. Do not nick braid or center conductor during strip operations. Tin center conductor if contact will be solder attached. Do not tin center conductor if contact is to be crimp attached. Slide crimp sleeve onto cable jacket.
3. Assemble contact onto cable.

Solder attachment: Solder contact to center conductor. Care should be taken that excess solder is not applied.

Crimp attachment: Crimp contact to center conductor using Johnson hand tool 140-0000-952 and die set 140-0000-953. Crimp location should be centered between end of contact and cross-hole. Crimp attachment to solid center conductor cables is not recommended.
4. Slide body assembly over contact and under braid, then seat firmly onto contact. The body assembly will “snap” over the contact barb. The cable may have to be held in a soft jawed clamping fixture. Slide crimp sleeve forward and crimp using recommended crimp die hex.

Cable Group	Part No.	Crimp Hex
RG-316/U, 188, 161, 174	135-3303-001	.128 (3.25)
RG-316 DS, 188 DS, 187 DS	135-3304-001	.151 (3.83)
RG-179/U, 187	135-3333-001	.128 (3.25)
RG-316/u, 188, 174	135-9403-001	.128 (3.25)
RG-316 DS, 188 DS	135-9404-001	.151 (3.83)

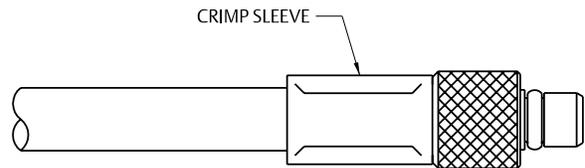
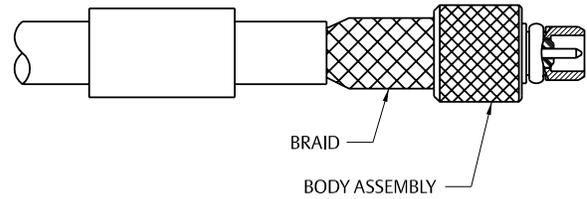
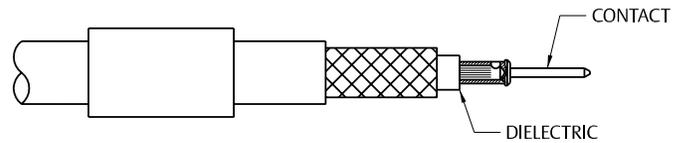
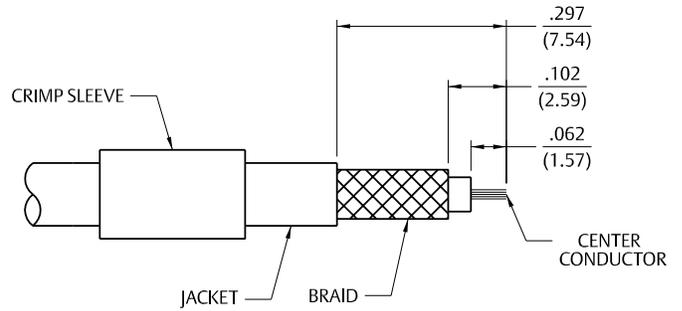
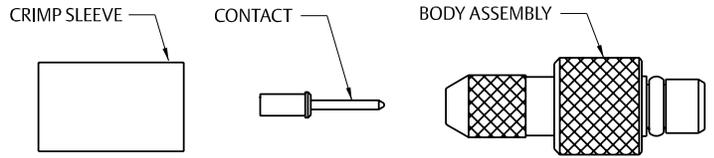

MCX Solder Type Straight Plug for Semi-Rigid Cable

1. Identify connector parts. (2 piece parts)
2. Strip cable to dimensions shown. Do not nick center conductor.
3. Place center contact on center conductor making sure contact bottoms against cable insulation. Solder center conductor to center contact through solder hole. Solder must not be allowed to run on outside of contact. Use a minimum amount of solder for a good joint. .020 (0.51) diameter solder is recommended. Trim excess insulation.
4. Insert contact and cable into body assembly making sure cable is bottomed against insulator in body. Solder body to cable. Use a minimum amount of heat to minimize cable insulation movement.

Cable Group	Part No.
RG-405/U (.086 Semi-Rigid)	133-3693-001
	133-3693-006

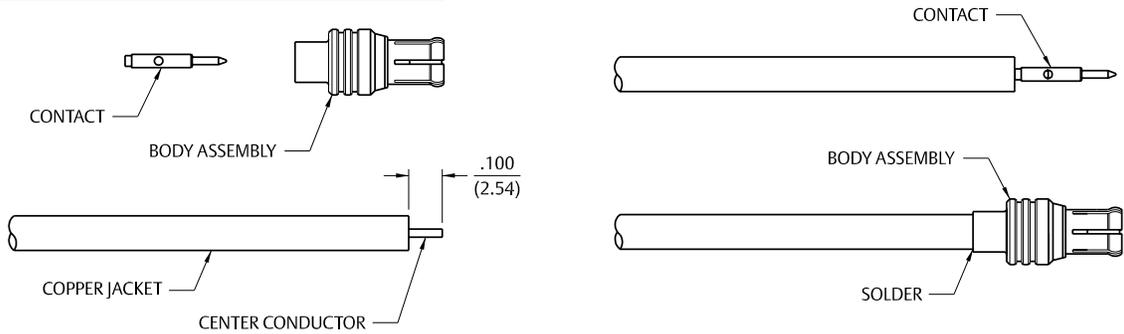

MCX Solder Type Right Angle Plug for Semi-Rigid Cable

1. Identify connector parts. (3 piece parts)
2. Strip cable to dimensions shown. Do not nick center conductor.
3. Insert cable into body making sure cable insulation bottoms on center contact. Solder center conductor to contact through the rear access port. Use a minimum amount of solder for a good joint. .020 (0.51) diameter solder is recommended.
4. Solder body to cable. Use a minimum amount of heat to minimize cable insulation movement. Assemble insulator then place expansion cap in access port and seat with a .156 (3.96) diameter punch or hand tool 141-0000-908.

Cable Group	Part No.
RG-405/U (.086 Semi-Rigid)	133-3693-101
	133-3693-106

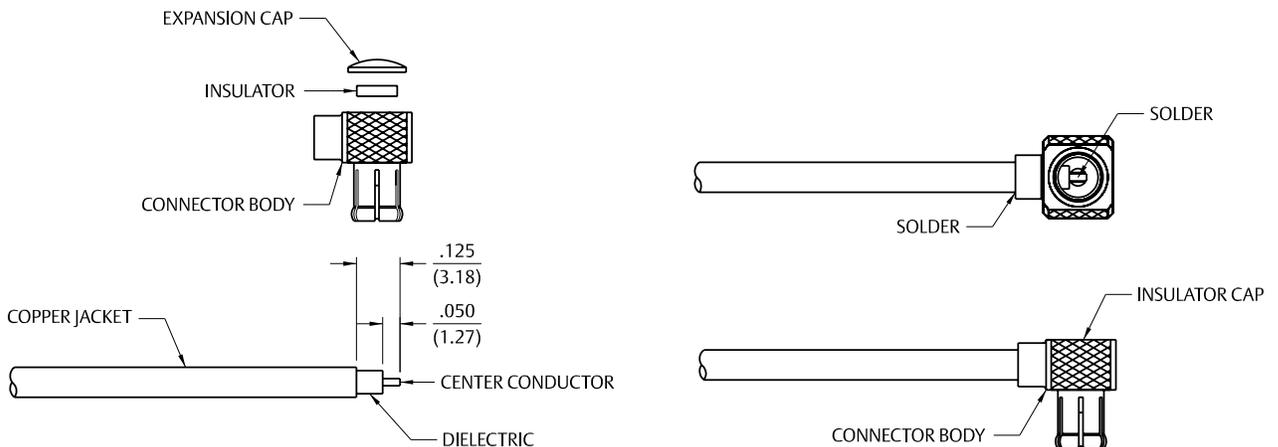

MCX Crimp Type Right Angle Plugs for Flexible Cable

1. Identify connector parts. (4 piece parts).
2. Strip cable to dimensions shown. Do not nick braid or center conductor. A wire stripper of correct size is recommended for this step. Twist stranded center conductor into tight bundle and tin (optional). Slide crimp sleeve onto cable as shown.
3. Flare braid and slide cable into body making certain that the cable dielectric bottoms against center contact. Solder: Solder center conductor to contact through the side access ports and hole in center contact. Use a minimum amount of solder for a full fillet joint. .015 (0.38) diameter solder is recommended. Crimp: Crimp Contact Attachment Crimp contact using 41-0000-924 dieset in 144-0000-900 tool frame.
4. Arrange braid uniformly around crimp stem. Slide crimp sleeve over braid and access ports. Crimp securely using recommended hex size and crimp tool.

Cable Group	Part No.	Sleeve Hex
RG-316/U, 188, 174	133-9403-101/104	.128 (3.25)
RG-316 DS, 188 DS	133-9404-101	.151 (3.83)
RG-178	133-9402-101	.105 (2.67)

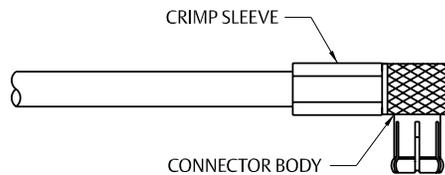
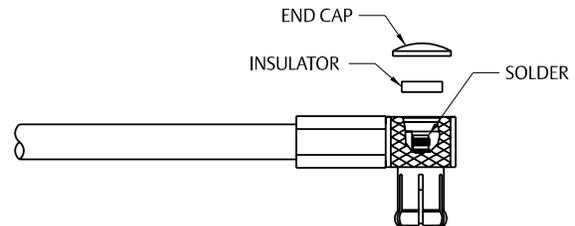
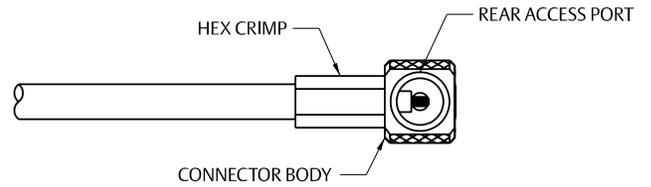
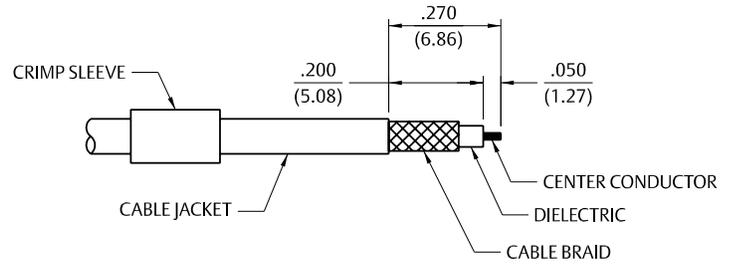
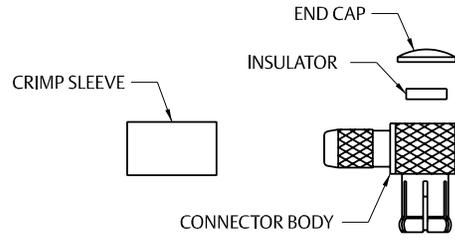

MCX Crimp Type Right Angle Plugs for Flexible Cable – 50 Ohm

1. Identify connector parts. (4 piece parts except RG-58)
2. Strip cable to dimensions shown. Do not nick braid or center conductor. A wire stripper of correct size is recommended for this step. Twist stranded center conductor into tight bundle and tin (optional). Slide crimp sleeve onto cable shown.
3. Flair braid and slide cable into body making certain that the cable insulation bottoms on center contact. Arrange braid uniformly around crimp stem. Slide crimp sleeve over braid and crimp securely using recommended crimp tool.
4. Solder center conductor to contact through rear access port. Use a minimum amount of solder for a full fillet joint. .020 (0.51) diameter solder is recommended.
5. Assemble insulator, if applicable; then place expansion cap in access port and seat with .156 (3.96) diameter flat punch or MCX hand assembly tool 141-0000-908. Shrink heat shrink tubing over crimp sleeve if applicable.

Cable Group	Part No.	"A"	"B"	"C"	Crimp Hex
RG-178/U, 196	133-3402-101/106	.050 (1.27)	.270 (6.86)	.200 (5.08)	.105 (2.67)
RG-188/U, 316, 161, 174	133-3403-101/106	.050 (1.27)	.270 (6.86)	.200 (5.08)	.128 (3.25)
RG-316 DS, 188 DS	133-3404-101/106	.050 (1.27)	.270 (6.86)	.200 (5.08)	.151 (3.83)
RG-179/U, 187	133-3433-101/106	.050 (1.27)	.270 (6.86)	.200 (5.08)	.128 (3.25)
RG-178/U, 196	133-5402-101/106	.050 (1.27)	.270 (6.86)	.200 (5.08)	.105 (2.67)
RG-188/U, 316, 161, 174	133-5403-101/106	.050 (1.27)	.270 (6.86)	.200 (5.08)	.128 (3.25)
RG-316 DS, 188 DS	133-5404-101/106	.050 (1.27)	.270 (6.86)	.200 (5.08)	.151 (3.83)
RG-58/U, 303, 141	133-3407-101/106	.067 (1.70)	.295 (7.49)	.210 (5.33)	.213 (5.41)

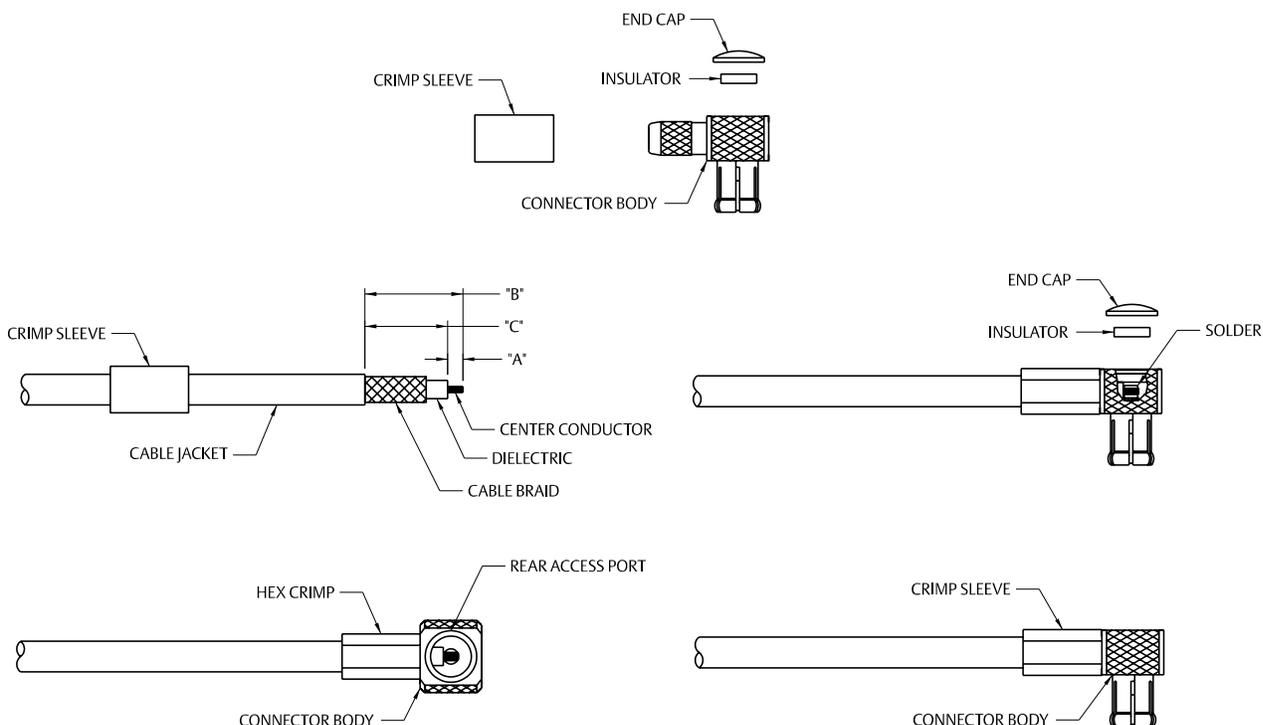

SMK Solder Type Straight Plugs for Semi-Rigid Cable



1. Identify connector parts (5 piece parts) and tools (5 tools.)
2. Strip cable jacket and dielectric to dimension shown.
3. Place center contact onto center conductor. Slide contact soldering tool onto contact. Clamp the cable contact and tool into cable soldering vise and solder contact to center conductor. High temperature solder, such as 95/5 Sn/Ag is recommended so that contact solder joint remains stable during body soldering operation. Solder paste is recommended for the contact solder joint to minimize excess solder. The assembled contact dimension should be as shown.
4. Remove excess solder from contact with a sharp blade and clean contact. Check for presence of excess solder by sliding body soldering tool over the contact. Remove soldering tool.
5. Place connector nut and body on cable. Place connector body soldering tool over contact and thread the coupling nut and connector body firmly to the tool. Place cable subassembly into cable soldering vise. Clamp cable and soldering tool securely to insure the cable dielectric expansion will not disturb the cable in the vise during soldering. Place hot soldering iron on the connector body sleeve and apply solder from the opposite side. A low temp solder, such as 60/40 Sn/Pb is recommended for the body solder joint. Allow the soldered joint to cool and remove from fixture. Check contact location to the body. The best electrical results are achieved when the contact location is within a tolerance of $.060 \pm .001$.
6. Place bead onto neck portion of the tool. Thread Bead Assembly tool firmly into the coupling nut. Push the tool's plunger between your thumb and fingers to assemble the bead. Check bead location. Assemble seal ring onto body.

Tool	145-0693-001/002 (for .086 Semi-Rigid)	145-0694-001/02 (for .141 Semi-Rigid)
Semi-Rigid Cable Vise	140-0000-962	140-0000-962
Vise Stop	140-0000-968	140-0000-968
Bead Assy. Tool	140-0000-957	140-0000-957
Contact Soldering Tool	140-0000-960	140-0000-961
Body Soldering Tool	140-0000-958	140-0000-959
Cable Clamp Insert	140-0000-964	140-0000-965

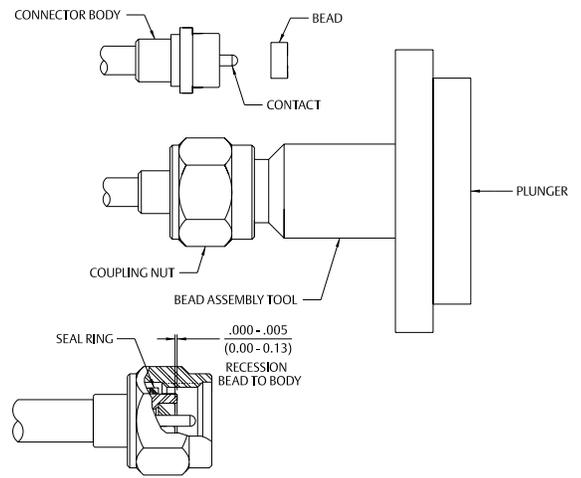
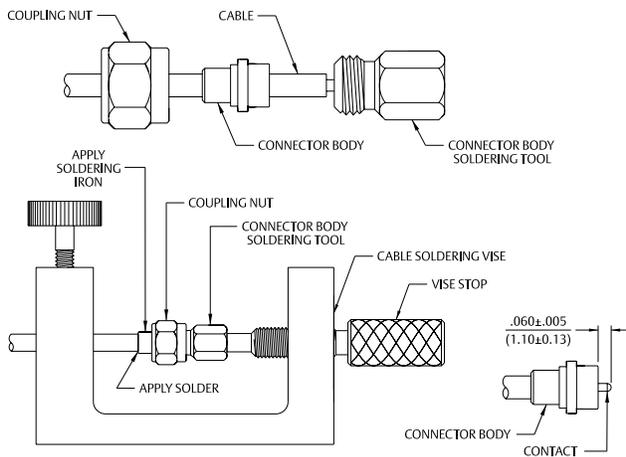
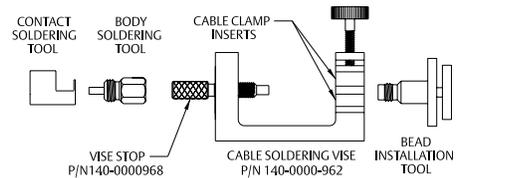
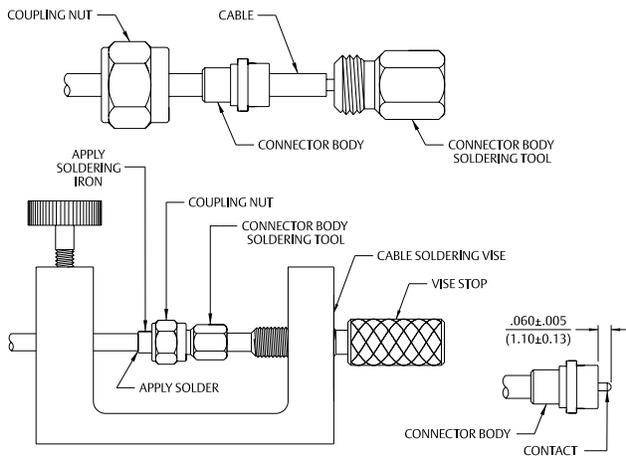
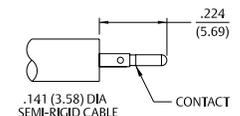
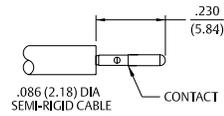
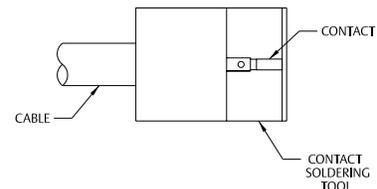
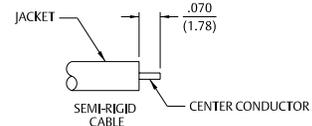

SMA Solder Type Straight Jacks, Straight Plugs, and Straight Bulkhead Jacks for Semi-Rigid Cable

1. Identify connector parts. (2 piece parts)
2. Strip cable to dimensions shown. Do not nick center conductor.
3. Place center contact on center conductor making sure contact bottoms against cable insulation. Solder center conductor to center contact through solder hole. Solder must not be allowed to run on outside of contact. Use a minimum amount of solder for a good joint. .020 (0.51) diameter solder is recommended. Trim excess insulation.
4. Insert contact and cable into body assembly making sure cable is bottomed against insulator in body. Solder body to cable. Use a minimum amount of heat to minimize cable insulation movement.

Cable Group	Part No.	"A"
RG-405/U (.086 Semi-Rigid)	141-0593-001	.070 (1.78)
	141-0593-401	.070 (1.78)
	141-0693-002	.070 (1.78)
RG-402/U (.141 Semi-Rigid)	141-0594-001	.085 (2.16)
	141-0594-401	.085 (2.16)
	141-0694-002	.085 (2.16)
RG-405/U (.086 Semi-Rigid)	142-0593-001/006	.070 (1.78)
	142-0593-401/406	.070 (1.78)
	142-0593-411/416	.070 (1.78)
	142-0693-001/006	.070 (1.78)
RG-402/U (.141 Semi-Rigid)	142-0594-001/006	.085 (2.16)
	142-0594-401/406	.085 (2.16)
	142-0694-001/006	.085 (2.16)

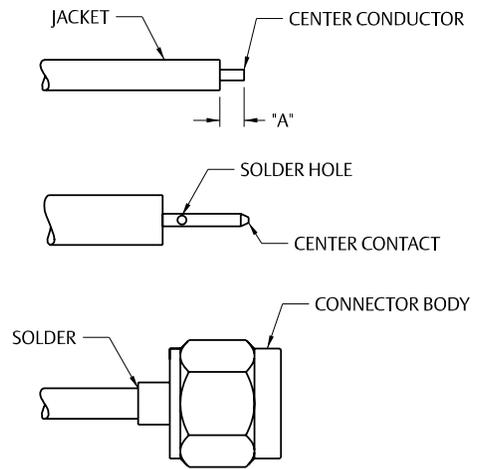
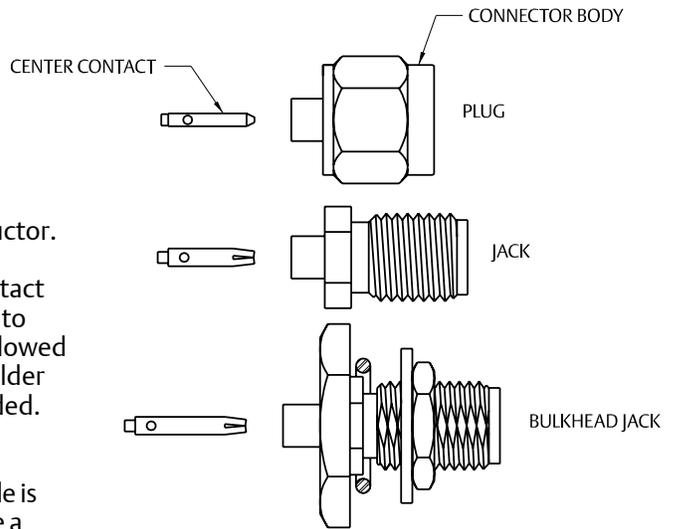

SMA Solder Type Straight Plugs for Semi-Rigid Cable

1. Identify connector parts. (2 piece parts)
2. Strip cable to dimensions shown. Do not nick center conductor. Bevel the cable center conductor per contact detail of SMA interface on page 48. Slide coupling nut onto cable as shown.
3. Insert cable into body making sure cable jacket is flush with front of body. Solder body to cable. Use a minimum amount of heat to minimize cable insulation movement. Trim expanded insulation flush with front of body or fixture body and cable during soldering to prevent cable insulation expansion.
4. Thread coupling nut over body.

Cable Group	Part No.
RG-402/U (.141 Semi-Rigid)	142-0694-011
	142-0694-016
	141-0694-012

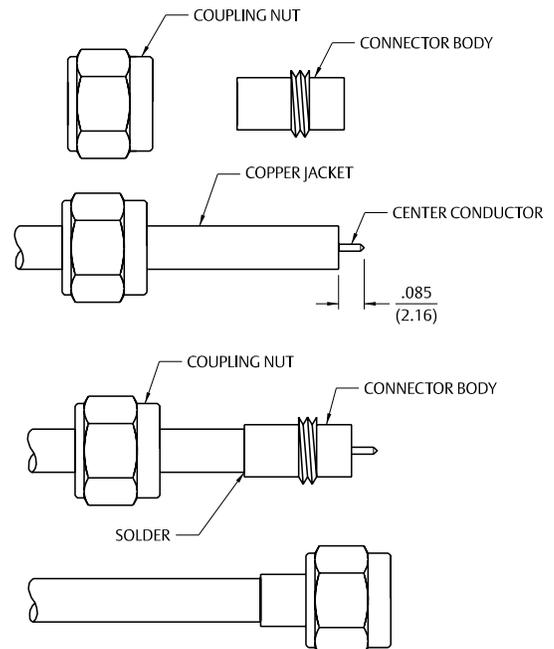

SMA Solder Type Straight Plugs for Semi-Rigid Cable

1. Identify connector parts. (3 piece parts)
2. Strip cable to dimensions shown. Do not nick center conductor. Slide coupling nut onto cable as shown.
3. Place center contact on center conductor making sure contact bottoms against cable insulation. Solder center conductor to center contact through solder hole. Solder must not be allowed to run on outside of contact. Use a minimum amount of solder for a good joint. .020 (0.51) diameter solder is recommended. Trim excess insulation.
4. Insert contact and cable into body making sure cable is bottomed against insulator in body. Solder body to cable. Use a minimum amount of heat to minimize cable insulation movement.
5. Thread coupling nut over body

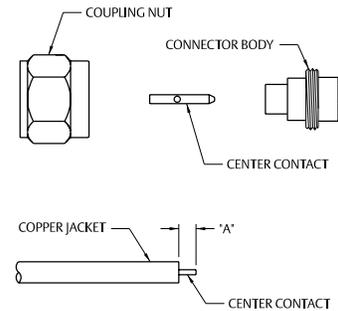
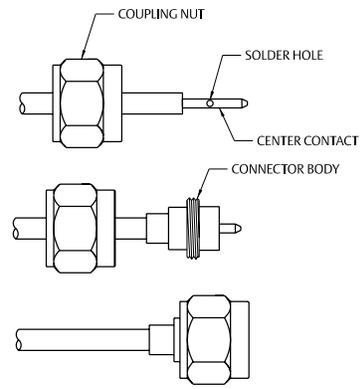

Cable Group	Part No.	"A"
RG-405/U (.086 Semi-Rigid)	142-0693-051	.070 (1.78)
	142-0693-056	.070 (1.78)
RG-402/U (.141 Semi-Rigid)	142-0694-051	.085 (2.16)
	142-0694-056	.085 (2.16)

SMA Solder Type Antenna Connector Plug for Flexible or Semi-Rigid Cable

1. Identify connector parts. (2 piece parts)
2. Strip cable to dimensions shown. Do not nick center conductor or braid on flexible cable.
3. **Flexible Cable Attachment:** Twist stranded center conductor into tight bundle and tin (optional). Slide cable into body, making sure cable insulation bottoms on center contact and braid fits inside stem. Solder center conductor to contact through the side access ports. Use a minimum amount of solder for a good joint. .020 (0.51) diameter solder is recommended. Solder braid to body. Use a minimum amount of solder to completely join the braid to the body.
Semi-Rigid Cable Attachments: Slide cable into body making certain cable insulation bottoms on center contact. Solder center conductor to contact through the side access ports. Use a minimum amount of solder for a good joint. .020 (0.51) diameter solder is recommended. Solder body to cable jacket. Use a minimum amount of heat to minimize cable insulation movement.

Cable Group	Part No.
RG-178/U, .047 Semi-Rigid	142-0801-421

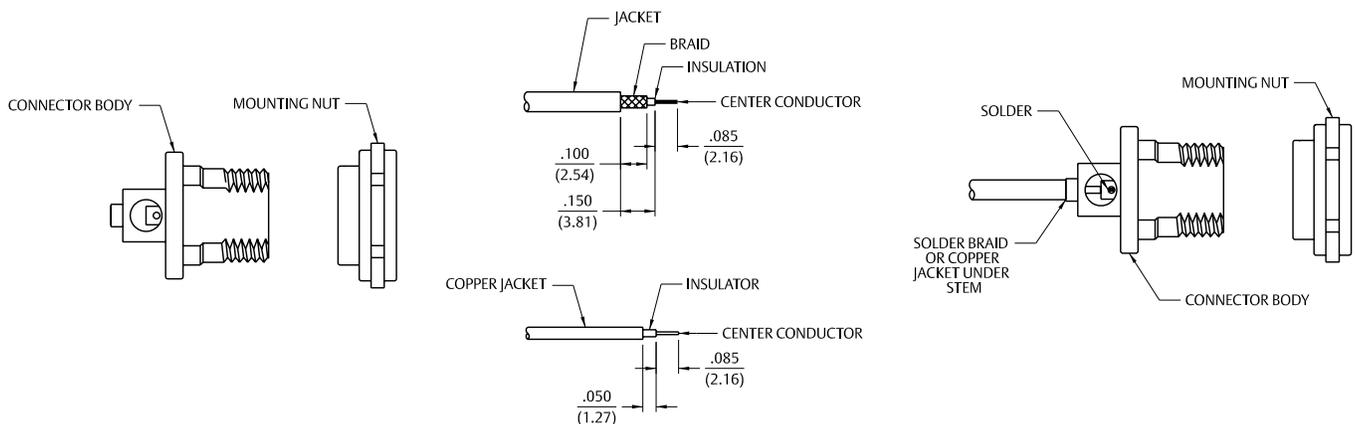

SMA Type Straight Plugs, Straight Jacks, and Straight Bulkhead Jacks for Flexible Cable – Crimp or Solder Contacts

1. Identify connector parts. (3 piece parts – except bulkhead)
2. Strip cable to dimensions shown. Do not nick braid or center conductor. Tin center conductor if contact will be solder attached. Do not tin center conductor if contact is to be crimp attached. When stripping LMR-100 low loss cable, remove foil back to where cable jacket is stripped. A wire stripper of correct size is recommended for this step. Slide heat shrink (as applicable) and crimp sleeve onto jacket of cable.
3. Assemble contact onto cable as shown.

Solder Attachment: Solder contact to center conductor through solder hole using .020 (0.51) diameter solder. Use a minimum amount of solder for a good joint.

Crimp Attachment: Crimp contact to center conductor using Johnson Hand Tool 144-0000-910, setting #2, with positioner 141-0000-907. Crimp location should be centered between end of contact and X-hole. Crimp attachment to solid center conductor cables is not recommended.
4. Flare braid and slide body assembly over contact and under braid. Then seat body assembly firmly onto contact. The cable may have to be held in a clamping fixture. Arrange braid uniformly around crimp stem. Slide crimp sleeve forward and crimp using recommended crimp tool. Slide heat shrink forward and shrink (as applicable).

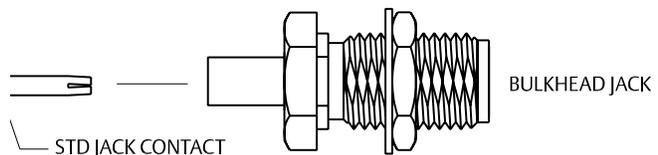
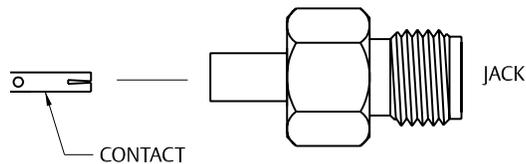
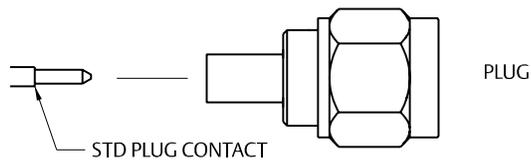
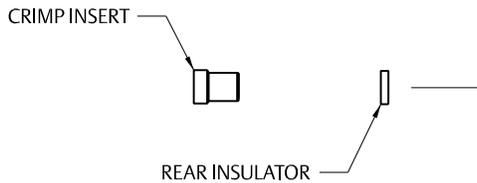
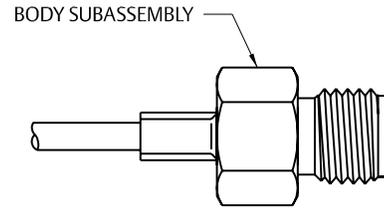
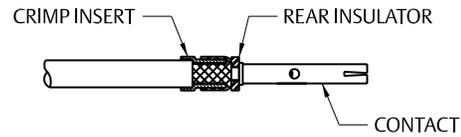
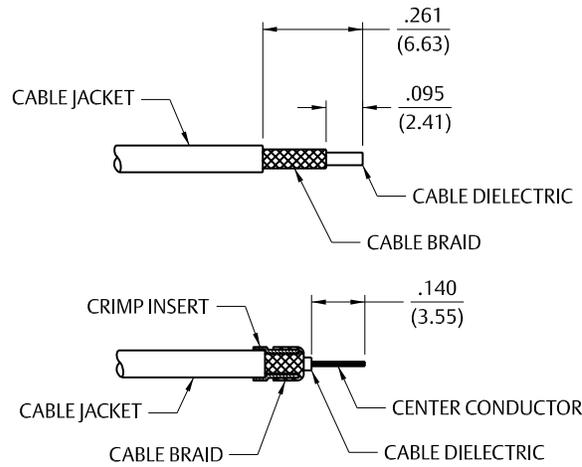

Straight SMA Low Loss Diameter .195, .200 and .240 Straight Type Plugs

1. Identify connector parts. (3 piece parts – except bulkhead)
2. Strip cable to dimensions shown. Do not nick braid, foil or center conductor. Cut foil flush with dielectric, do not remove foil. Make sure that dielectric is clean and free from all particles. Tin center conductor, keeping solder amount to a minimum. Slide crimp sleeve onto jacket of cable.
3. Assemble contact onto cable as shown. Position contact such that a gap of no more than .020 (0.51) is kept between dielectric and contact. Solder contact to center conductor through solder hole using .020 (0.51) Diameter solder. Use a minimum amount of solder for a good joint. Do not allow contact to move into dielectric during soldering process.
4. Flare braid and slide body assembly over contact, foil and dielectric, then under braid. Seat body assembly firmly onto contact. Arrange braid uniformly around crimp stem. Slide crimp sleeve forward and crimp using Johnson hand crimp tool 141-0000-913 and recommended crimp die hex.

Cable Group	Part No.	Crimp Hex
LMR-195	142-0307-411	.213 (5.41)
	142-0307-416	.213 (5.41)
LMR-240	142-0335-401	.255 (6.48)
	142-0335-406	.255 (6.48)
LMR-200	142-0339-401	.213 (5.41)
	142-0339-406	.213 (5.41)
LMR-195	142-0407-011	.213 (5.41)
	142-0407-016	.213 (5.41)
LMR-240	142-0435-001	.255 (6.48)
	142-0435-006	.255 (6.48)
LMR-200	142-0439-001	.213 (5.41)
	142-0439-006	.213 (5.41)
LMR-240	142-4435-001	.255 (6.48)
	142-4435-006	.255 (6.48)
LMR-200	142-4439-001	.213 (5.41)
	142-4439-006	.213 (5.41)
LMR-195	142-4407-001	.213 (5.41)
	142-4407-006	.213 (5.41)
LMR-240	142-5435-001	.255 (6.48)
	142-5435-006	.255 (6.48)
LMR-200	142-5439-001	.213 (5.41)
	142-5439-006	.213 (5.41)
LMR-195	142-5407-001	.213 (5.41)
	142-5407-006	.213 (5.41)

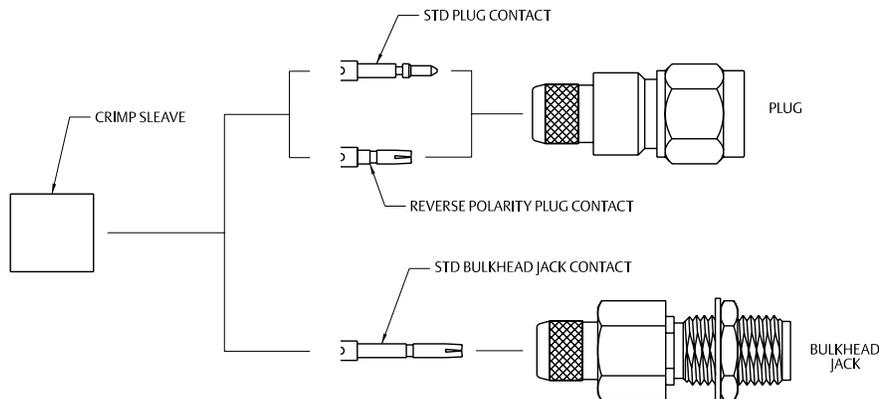
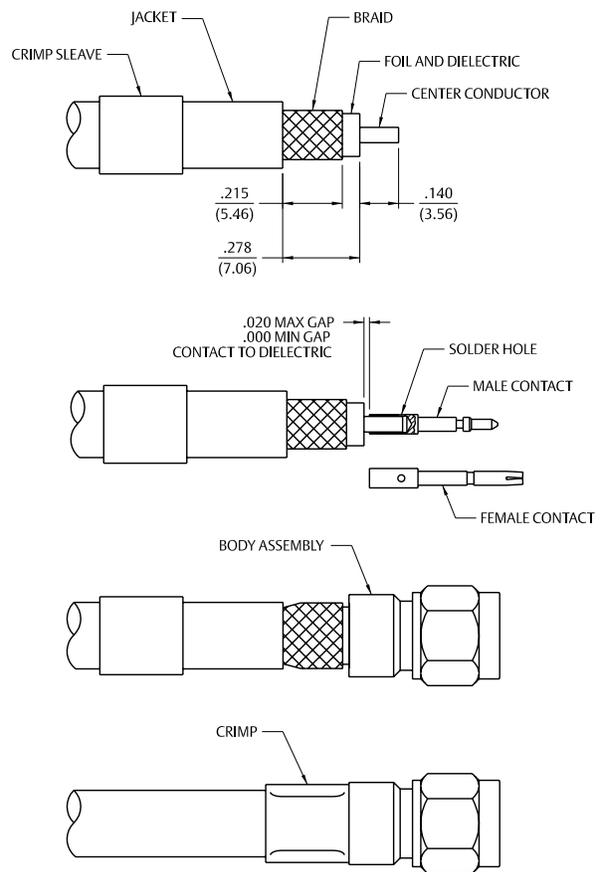

SMA Straight Solder Type for Semi-Rigid Cables (cont'd from last page)

Cable Group	Part No.
RG-405/U (.086 Semi-Rigid)	141-0593-421 141-0693-062
RG-402/U (.141 Semi-Rigid)	141-0594-421 141-0694-062

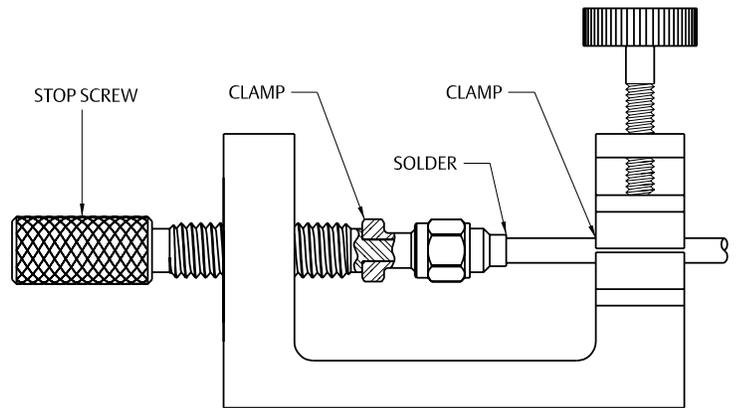
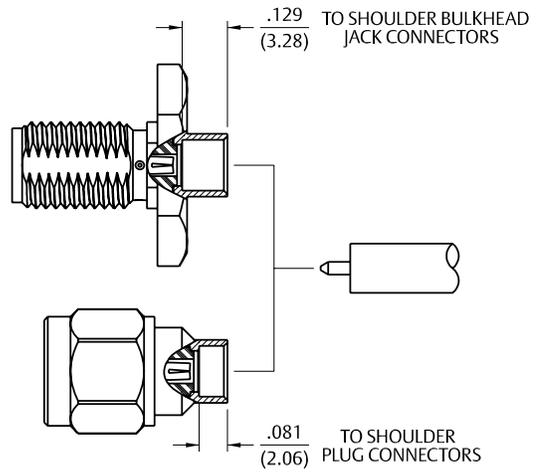

SMA Crimp Type Right Angle Plugs for Flexible Cable (cont'd from last page)

Cable Group	Part No.	Crimp Hex
RG-316/U, 161, 174, 188; LMR-100	141-0403-102	.128 (3.25)
RG-316 DS, 188 DS	141-0404-112	.151 (3.83)
RG-58/U, 141, 303	141-0407-102	.213 (5.41)
RG-55/U, 142, 223, 400	141-0408-102	.213 (5.41)
RG-178/U, 196	142-0402-101 142-0402-106	.105 (2.67) .105 (2.67)
RG-316/U, 161, 174, 188; LMR-100	142-0403-101 142-0403-106	.128 (3.25) .128 (3.25)
RG-316 DS, 188 DS	142-0404-101 142-0404-106	.151 (3.83) .151 (3.83)
RG-58/U, 141, 303	142-0407-101 142-0407-106	.213 (5.41) .213 (5.41)
RG-55/U, 142, 223, 400	142-0408-101 142-0408-106	.213 (5.41) .213 (5.41)
RG-179/U, 187	142-0433-101 142-0433-106	.128 (3.25) .128 (3.25)
RG-316/U, 161, 174, 188; LMR-100	142-4403-101 142-4403-106	.128 (3.25) .128 (3.25)
RG-316 DS, 188 DS	142-4404-101 142-4404-106	.151 (3.83) .151 (3.83)
RG-58/U, 141, 303	142-4407-101 142-4407-106	.213 (5.41) .213 (5.41)
RG-55/U, 142, 223, 400	142-4408-101 142-4408-106	.213 (5.41) .213 (5.41)
RG-316/U, 161, 174, 188; LMR-100	142-5403-101 142-5403-106	.128 (3.25) .128 (3.25)
RG-316 DS, 188 DS	142-5404-101 142-5404-106	.151 (3.83) .151 (3.83)
RG-58/U, 141, 303	142-5407-101 142-5407-106	.213 (5.41) .213 (5.41)
RG-55/U, 142, 223, 400	142-5408-101 142-5408-106	.213 (5.41) .213 (5.41)
RG-316/U, 188, 174	142-9403-101	.128 (3.25)
RG-316 DS, 188 DS	142-9404-101	.151 (3.83)
RG-58/U, 141	142-9407-101	.213 (5.41)

SMA High Frequency End Launch Connectors PC Mounting Instructions

High frequency end launch performance is dependent upon proper mounting. The following factors must be controlled for optimum performance:

- The connector should fit tightly against the circuit board edge, avoid gaps.
- The center contact pin must lie parallel and flat against the circuit board, avoid gaps.
- The contact pin should be centered on the circuit board signal trace.
- Use a minimal amount of solder between the contact pin and signal trace. Do not allow excess solder to build up or flow down the trace.
- Clean all excess flux and other residue from the launch area, especially between the trace and ground.

The basic steps required to mount the end launch connector to the circuit board are as follows:

- Fixture 140-0000-973 should be used as an aid during manual soldering. The fixture protects the connector from damage during clamping and also maintains the proper location of the connector's insulator and contact. To use the fixture, thread the coupling nut on the mating end of the connector and hand tighten. This mounting assembly can now be held in a vice or similar clamping device, as shown in Figure 1.
- Position connector on the circuit board, making sure the contact pin is aligned with the center of the signal trace as shown in Figure 2. Make sure that the connector legs and contact pin are held flush against the top of the circuit board, keeping the axis of the connector parallel to the plane of the circuit board, as shown in Figure 3.
- A small amount of Teflon® insulation projects from rear mating plane of the connector, which acts as a seal when soldering the center conductor pin to the trace. Clamp the connector tightly against the edge of the board. This action compresses the insulator seal against the board edge. This effectively creates a barrier between the inner and outer conductors, preventing the bridging of solder.
- While ensuring the connector is held in the correct position, solder the ground legs and/or ground posts to the top and bottom of the board prior to bonding the center pin to the trace.
- Once the connector body is properly grounded to the board, the center contact pin can be bonded to the trace by using a minimal amount of solder as shown in Figure 4. It is important that solder flows along the length of the exposed pin, creating a good electrical and mechanical connection. Remove any excess solder that is not required for a solid joint.
- Clean all flux and other residues from the trace area between the signal side ground legs, as any flux present between the signal trace and ground will affect performance. The completed mounting assembly should look similar to the one shown in Figure 5.

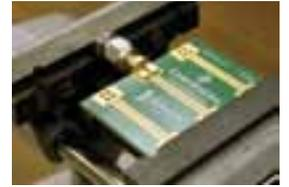

Figure 1



Figure 2



Figure 3

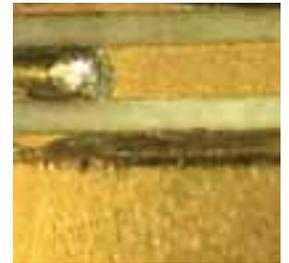

Figure 4

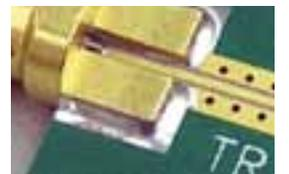

Figure 5

Reference dimensions for 50 Ohm grounded coplanar waveguide using Rogers Corporation RO4003C™ high frequency substrate laminate*

Holes	GCPW 50Ω Impedance Reference Dimensions*				Mounting and Via		
Part No.	Substrate Thickness	Conductor Thickness	Trace Width "A"	Ground Gaps "B"	Fig	"C"	"D"
142-0761-801	.0080 (0.203)	.0014 (0.036)	.0155 (0.394)	.0100 (0.254)	1	.066 (1.68)	.096 (2.44)
142-0761-811	.0080 (0.203)	.0014 (0.036)	.0155 (0.394)	.0100 (0.254)	1	.066 (1.68)	.096 (2.44)
142-0761-821	.0160 (0.406)	.0014 (0.036)	.0285 (0.724)	.0100 (0.254)	1	.084 (2.13)	.113 (2.87)
142-0761-831	.0160 (0.406)	.0014 (0.036)	.0285 (0.724)	.0100 (0.254)	1	.084 (2.13)	.113 (2.87)
142-0761-841	.0080 (0.203)	.0014 (0.036)	.0155 (0.394)	.0100 (0.254)	2	.066 (1.68)	
142-0761-851	.0080 (0.203)	.0014 (0.036)	.0155 (0.394)	.0100 (0.254)	2	.066 (1.68)	
142-0761-861	.0160 (0.406)	.0014 (0.036)	.0285 (0.724)	.0100 (0.254)	2	.084 (2.13)	
142-0761-871	.0160 (0.406)	.0014 (0.036)	.0285 (0.724)	.0100 (0.254)	2	.084 (2.13)	
142-0761-881	.0080 (0.203)	.0014 (0.036)	.0155 (0.394)	.0100 (0.254)	1	.066 (1.68)	.096 (2.44)
142-0761-891	.0080 (0.203)	.0014 (0.036)	.0155 (0.394)	.0100 (0.254)	2	.066 (1.68)	
142-0771-821	.0160 (0.406)	.0014 (0.036)	.0285 (0.724)	.0100 (0.254)	1	.084 (2.13)	.113 (2.87)
142-0771-831	.0160 (0.406)	.0014 (0.036)	.0285 (0.724)	.0100 (0.254)	2	.084 (2.13)	

* These calculated dimensions assume a quasi-static mode of propagation, but dispersion does exist for coplanar waveguide. The characteristic impedance and effective dielectric constant may increase slightly for X-band and higher frequencies, unless very small ground to ground gap spacing is used.

It is assumed the conductors have rectangular cross-sections. The etching process used in circuit board fabrication actually produces trapezoidal shapes. Therefore, the GCPW impedance may increase somewhere between that of a perfect rectangular conductor and a theoretical zero thickness conductor.



Figure 1

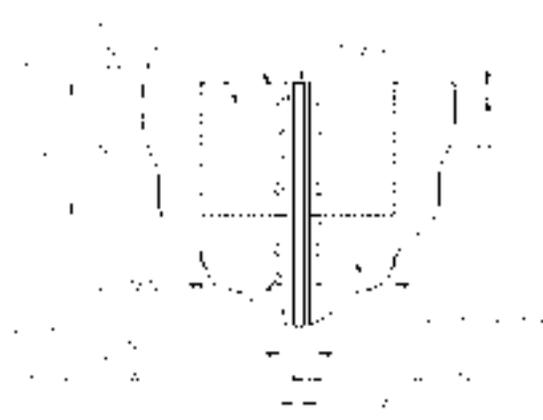
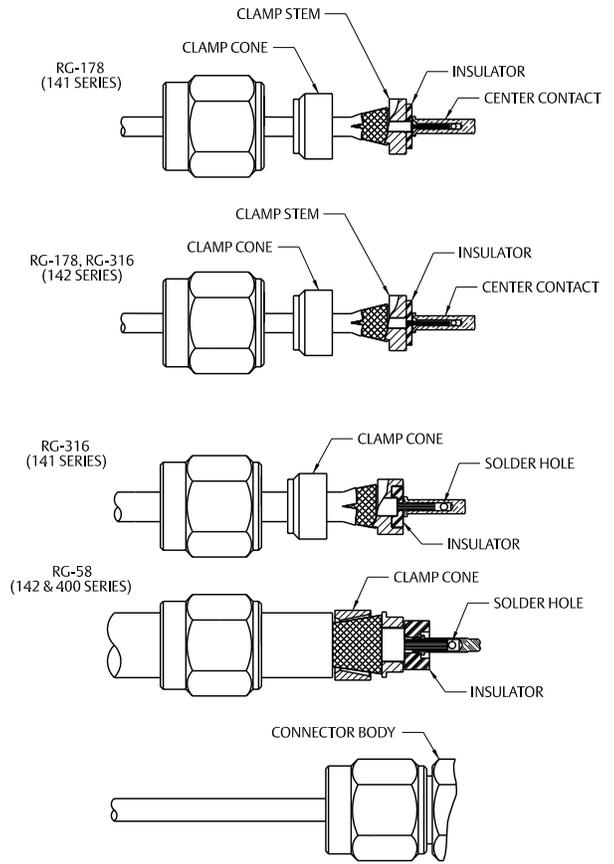

Figure 2

SMA Clamp Type Straight Plugs, Straight Jacks, and Straight Bulkhead Jacks for Flexible Cable

1. Identify connector parts. (6 piece parts – except bulkhead)
2. Strip cable to dimensions shown. Do not nick braid or center conductor. A wire stripper of correct size is recommended for this step. Twist stranded center conductor into tight bundle and tin (optional). Slide clamp nut and clamp cone onto cable as shown. Clamp cone must be oriented as shown for each size of cable. The RG-58/142 clamp cone slides over braid and against jacket.
3. Flare braid and slide cable into clamp stem. Place rear insulator and center contact over center conductor and position as shown for different cable sizes. Solder center conductor to contact through the solder hole. Solder must not be allowed to gather and run on outside of contact. Use a minimum amount of solder for a good joint. .020 (0.51) diameter solder is recommended.
4. Arrange braid uniformly around clamp stem. Slide center contact assembly into body. Slide clamp nut against clamp cone and braid and tighten to 10 in.-lb. torque.



Cable Group	Part No.	"A"	"B"	"C"
RG-178/U, 196	142-0202-011/016	.133 (3.38)	.053 (1.35)	.085 (2.16)
RG-161/U, 174, 188, 316	142-0203-011/016	.133 (3.38)	.053 (1.35)	.085 (2.16)
RG-58/U, 141, 303	142-0207-011/016	.225 (5.72)	.145 (3.68)	NONE
RG-142, 223, 55, 400	142-0207-011/016	.285 (7.24)	.165 (4.19)	NONE
RG-178/U, 196	142-0102-401/406	.133 (3.38)	.053 (1.35)	.085 (2.16)
RG-161/U, 174, 188, 316	142-0103-401/406	.133 (3.38)	.053 (1.35)	.085 (2.16)
RG-58/U, 141, 303	142-0107-401/406	.225 (5.72)	.145 (3.68)	NONE
RG-142, 223, 55, 400	142-0107-401/406	.285 (7.24)	.165 (4.19)	NONE

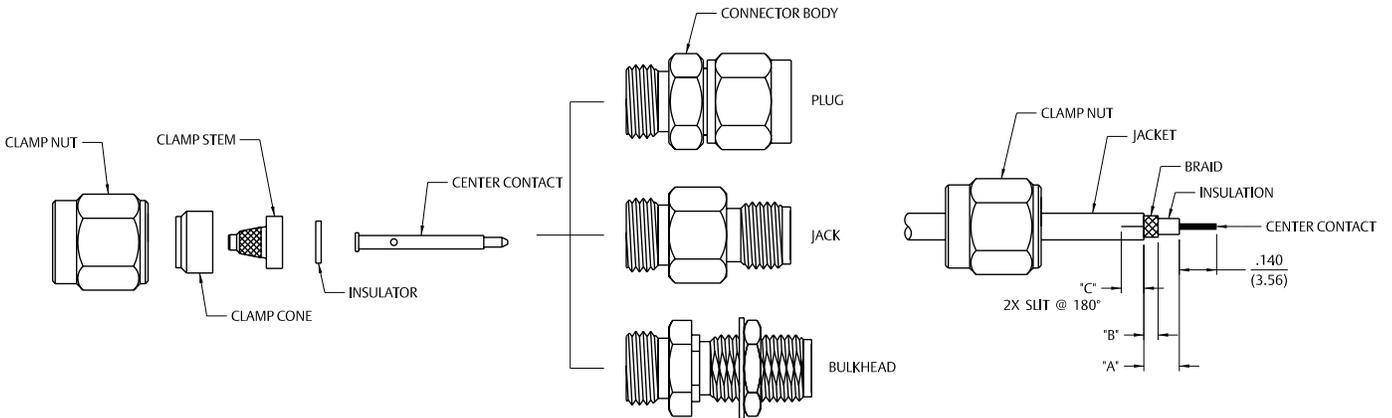

SMB 3-Piece Straight Plugs

1. Identify connector parts. (3 piece parts): Crimp sleeve, body assembly and contact
2. Strip cable to dimensions shown. Do not nick braid or center conductor. Tin center conductor if contact will be solder attached. Do not tin center conductor if contact is to be crimp attached. Slide heat shrink (as applicable) and crimp sleeve onto jacket of cable.
3. Assemble contact onto cable as shown.

Solder Attachment: Solder contact to center conductor through solder hole using .015 (0.38) diameter solder. Use a minimum amount of solder for a good joint.

Crimp Attachment: A miniature 8 indent crimp tool 140-0000-970 is recommended. Crimp location should be centered between end of contact and X-hole using positioner 140-0000-971. Crimp attachment to solid center conductor cables is not recommended.
4. Flare braid and slide body assembly over contact and under braid. Then seat body assembly firmly onto contact. The cable may have to be held in a clamping fixture. Arrange braid uniformly around crimp stem. Slide crimp sleeve forward and crimp using recommended crimp tool. Slide heat shrink forward and shrink (as applicable).

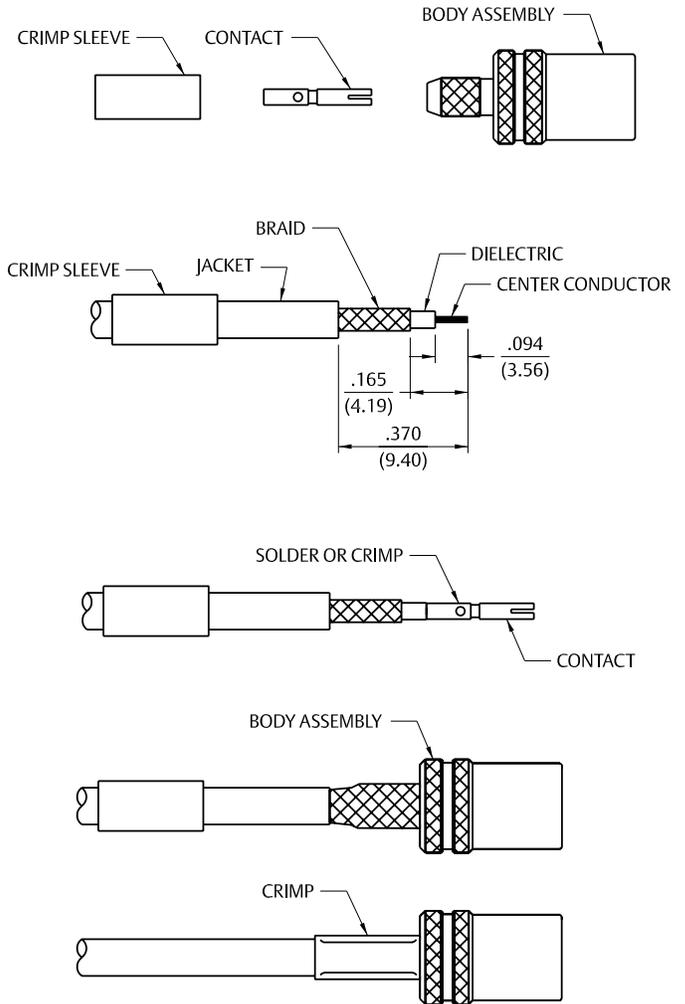

Cable Group	Part No.	Crimp Hex
RG-316/U, 161, 174, 179, 187, 188	131-3403-021/026	.128 (3.25)
RG-316 DS, 188 DS, 179 DS	131-3404-021/026	.151 (3.83)
RG-58/U, 141, 303	131-3407-011/016	.213 (5.41)
RG-179/U, 187	131-8433-001/006	.128 (3.25)
RG-179 DS, 187 DS	131-8434-001/006	.151 (3.83)
Belden 735A	131-8445-011/016	.178 (4.52)
RG-316/U, 188, 174, 179, 187	131-9403-021	.128 (3.25)
RG-316 DS, 188 DS, 179 DS, 187 DS	131-9404-021	.151 (3.83)

SMB/SMC Solder Type Right Angle Plugs for Semi-Rigid Cable

1. Identify connector parts. (2 piece parts – except diecast)
2. Strip cable to dimensions shown. Do not nick center conductor.
3. Insert cable into body making certain that the cable insulation bottoms on center contact. Solder center conductor to contact through the rear and side access ports. Use a minimum amount of solder for a good joint. .020 (0.51) diameter solder is recommended.
4. Solder body to cable. Use a minimum amount of heat to minimize cable insulation movement. Place expansion cap in access port and set with .125 (3.17) diameter punch. Snap cover ring over side access port.

Cable Group	Part No.
RG-405/U (.086 Semi-Rigid)	131-1693-101
	131-1693-116
	131-3693-101
	131-3693-116

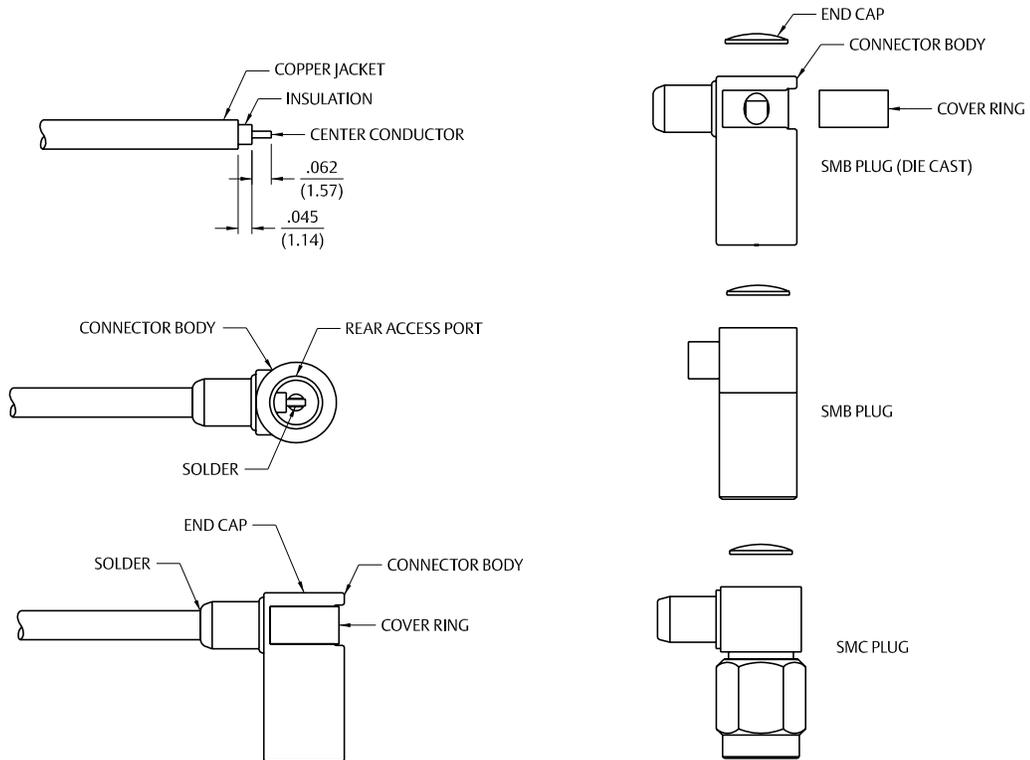

SMB Right Angle Crimp Type Straight Plugs for Flexible Cable

1. Identify connector parts. (3 piece parts: crimp sleeve, body assembly and expansion cap.)
2. Strip cable to dimensions shown. Do not nick braid or center conductor. A wire stripper of correct size is recommended for this step. Twist stranded center conductor into tight bundle and tin (optional). Slide crimp sleeve onto cable as shown.
3. Flare braid and slide cable into body assembly making certain that the cable insulation bottoms on center contact. Arrange braid uniformly around crimp stem of body assembly. Slide crimp sleeve over braid and crimp securely using recommended crimp tool.
4. Solder center conductor to contact through the rear and side access ports. Use a minimum amount of solder for a good joint. .020 (0.51) diameter solder is recommended. Place expansion cap in access port and seat with a .125 (3.17) diameter flat punch. Snap cover ring over side access port.

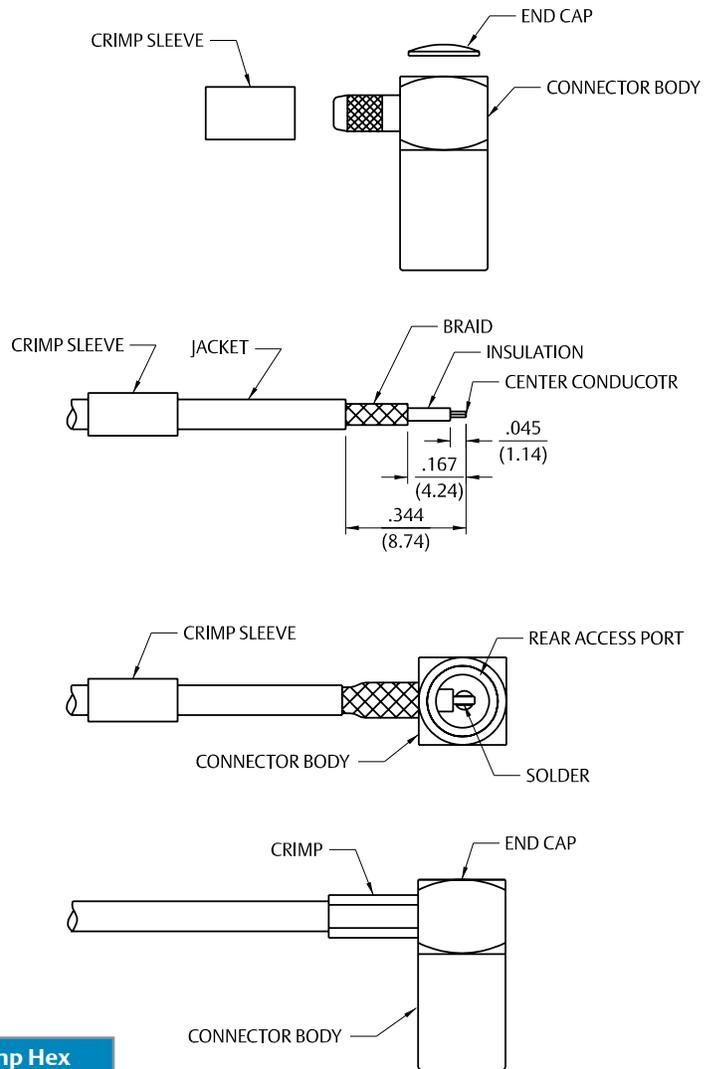

Cable Group	Part No.	Crimp Hex
RG-316/U, 188, 174, 179, 187	131-9403-101 / -116	.128 (3.25)
RG-316 DS, 188 DS, 179 DS, 187 DS	131-9404-101 / -116	.151 (3.83)

SMB/SMC/Mini-75Ohm SMB Crimp Type Right Angle Plugs and Right Angle Bulkhead Jacks for Flexible Cable

1. Identify connector parts. (4 piece parts: crimp sleeve, body assembly, expansion cap and covering ring. Die cast body only.)
2. Strip cable to dimensions shown. Do not nick braid or center conductor. A wire stripper of correct size is recommended for this step. Twist stranded center conductor into tight bundle and tin (optional). Slide crimp sleeve onto cable as shown.
3. Flare braid and slide cable into body assembly making certain that the cable insulation bottoms on center contact. Arrange braid uniformly around crimp stem of body assembly. Slide crimp sleeve over braid and crimp securely using recommended crimp tool.

4. Solder center conductor to contact through the rear and side access ports. Use a minimum amount of solder for a good joint. .020 (0.51) diameter solder is recommended. Place expansion cap in access port and seat with a .125 (3.17) diameter flat punch. Snap cover ring over side access port if applicable.

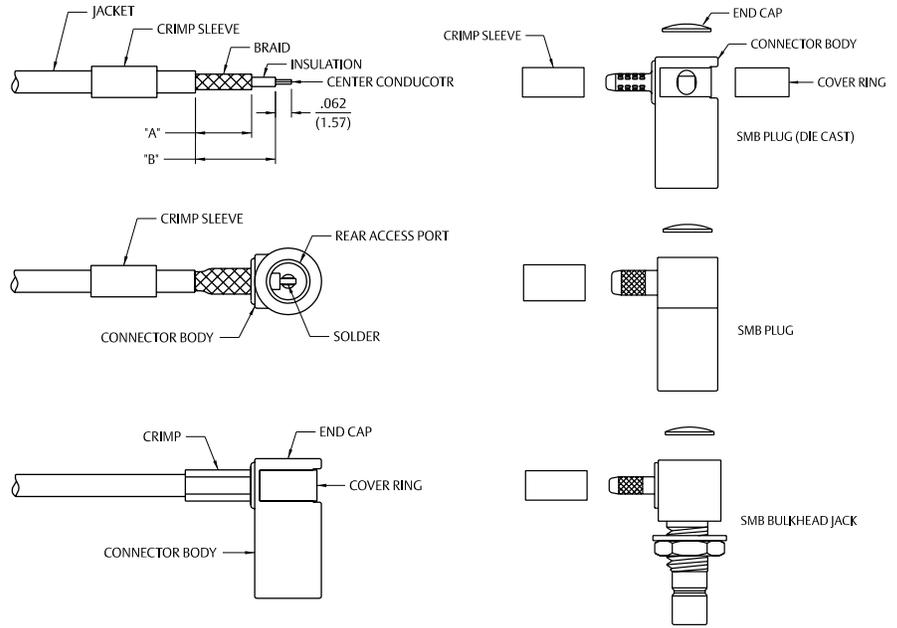

Cable Group	Part No.	"A"	"B"	Crimp Hex
RG-178/U, 196	131-1402-101/116	.219 (5.56)	.312 (7.92)	.105 (2.67)
RG-316/U, 161, 174, 179, 187, 188	131-1403-101/116	.219 (5.56)	.312 (7.92)	.128 (3.25)
RG-179 DS, 187 DS, 188DS, 316 DS	131-1404-101/116	.219 (5.56)	.312 (7.92)	.151 (3.83)
RG-316/U, 161, 174, 179, 187, 188	131-3303-501/506	.219 (5.56)	.312 (7.92)	.128 (3.25)
RG-179 DS, 187 DS, 188 DS, 316 DS	131-3304-501/506	.219 (5.56)	.312 (7.92)	.151 (3.83)
RG-178/U, 196	131-3402-101/116	.177 (4.50)	.289 (7.34)	.105 (2.67)
RG-316/U, 161, 174, 179, 187, 188	131-3403-101/116	.177 (4.50)	.289 (7.34)	.128 (3.25)
RG-179 DS, 187 DS, 188 DS, 316 DS	131-3404-101/116	.177 (4.50)	.289 (7.34)	.151 (3.83)
RG-58/U, 141, 303	131-3407-101/106	.219 (5.56)	.289 (7.34)	.213 (5.41)
RG-316/U, 161, 174, 188	131-6403-101/106	.219 (5.56)	.312 (7.92)	.128 (3.25)
316 DS, 188 DS	131-6404-101/106	.219 (5.56)	.312 (7.92)	.151 (3.83)
RG-179/U, 187	131-6433-101/106	.219 (5.56)	.312 (7.92)	.151 (3.83)
RG-179/U, 187, 316,	131-8403-101/106	.177 (4.50)	.289 (7.34)	.128 (3.25)
161, 174, 188	131-8403-111/116	.219 (5.56)	.312 (7.92)	.128 (3.25)
RG-179 DS, 187 DS	131-8404-101/106	.177 (4.50)	.289 (7.34)	.151 (3.83)
316 DS, 188 DS	131-8404-111/116	.219 (5.56)	.312 (7.92)	.151 (3.83)
RG-59	131-8409-101/106	.219 (5.56)	.289 (7.34)	.255 (6.48)
BELDEN 735A	131-8445-101/106	.177 (4.50)	.289 (7.34)	.178 (4.52)
RG-316/U, 188, 174, 179, 187	131-9403-101/116	.177 (4.50)	.289 (7.34)	.128 (3.25)
RG-316 DS, 188 DS, 179 DS, 187 DS	131-9404-101/116	.177 (4.50)	.289 (7.34)	.151 (3.83)

Type N Straight Crimp Type Plugs for Flexible Cable

- Identify connector parts. (3 piece parts – except bulkheads)
- Strip cable to dimensions shown. Do not nick braid or center conductor. Tin center conductor if contact will be solder attached. Do not tin center conductor if contact is to be crimp attached. A wire stripper of correct size is recommended for this step. Slide heat shrink (as applicable) and crimp sleeve onto jacket of cable.
- Assemble contact onto cable as shown.

Solder Attachment: Solder contact to center conductor through hole using a minimum amount of solder for a good joint.

Crimp Attachment (where applicable): Crimp contact to center conductor using recommended crimp hex.
- Flare braid and slide body assembly over contact and under braid. Then seat body assembly firmly onto contact. The cable may have to be held in a clamping fixture. Arrange braid uniformly around crimp stem. Slide crimp sleeve forward and crimp using recommended crimp hex. Slide heat shrink forward and shrink (as applicable).

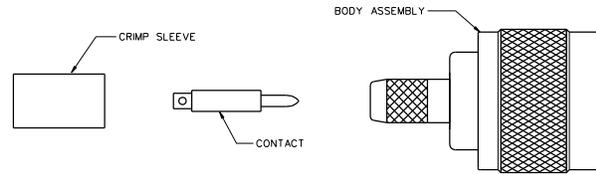

A

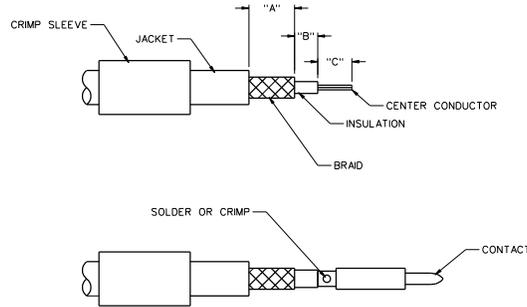

B

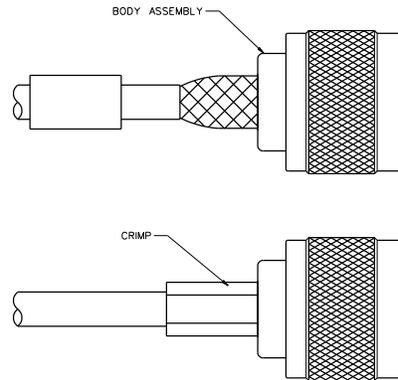

C

Part No.	Cable	Strip Dimensions			Crimp Sleeve Hex	Contact Crimp Hex	Recommended Crimp
		"A"	"B"	"C"			
CPN681	RG-58	.335 (8.50)	.079 (2.00)	.157 (4.00)	.215 (5.46)	.065 (1.65)	24-8858P
CPN6813	RG-142	.335 (8.50)	.079 (2.00)	.157 (4.00)	.215 (5.46)	.065 (1.65)	24-8858P
CPN688	RG-8, 213	.354 (9.00)	.138 (3.50)	.157 (4.00)	.429 (10.90)	.100 (2.54)	24-313
138-4408-007	RG-55/U, 142, 223, 400	.301 (7.65)	.140 (3.56)		.213 (5.41)	.068 (1.73)	.113 (2.87)
138-4449-007	LMR-400, BELDEN 9913	.385 (9.78)	.170 (4.32)		.429 (10.90)	.116 (2.95)	

Type N Straight Plug Crimp Style for RG-316 and 316DS Flexible Cable

- 1 Identify connector parts. (3 piece parts)
- 2 Strip cable to dimensions shown. Do not nick center conductor. A wire stripper of correct size is recommended for this step. Tin center conductor if contact will be solder attached. Do not tin center conductor if contact will be crimp attached. Slide crimp sleeve onto jacket of cable.
3. Assemble rear contact onto cable as shown
Rear contact should butt against cable dielectric during attachment.
Solder Attachment: Solder rear contact to center conductor through solder hole using .020 (.051) diameter flux core solder wire. Use a minimum amount of solder for a good joint.
Crimp Attachment: Crimp rear contact to center conductor using Johnson indent hand tool 140-0000-970. Crimp location should be centered between end of rear contact and solder hole using positioning tool 140-0000-971. Crimp attachment to solid center conductor cables is not recommended.
4. Flare braid and slide plug connector assembly over rear contact and under braid. Rear contact must engage fully with internal captivated plug contact. Cable jacket should be located near end of crimp stem when contacts are fully engaged.
5. Arrange braid uniformly around crimp stem. Slide crimp sleeve forward and crimp using Johnson ergonomic hand crimp frame 140-0000-967 with recommended hex size die set. Maintain forward pressure on cable while crimping.

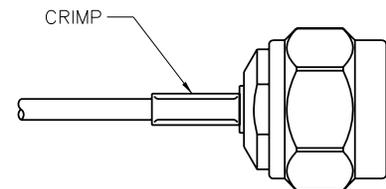
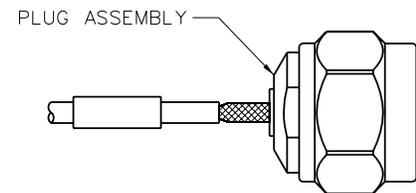
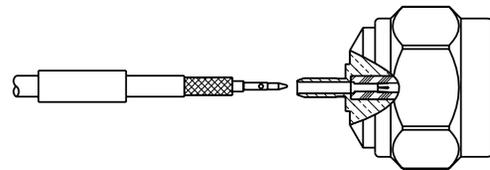
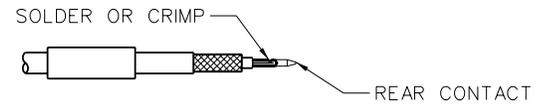
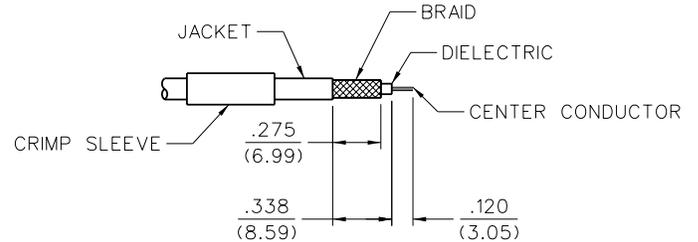
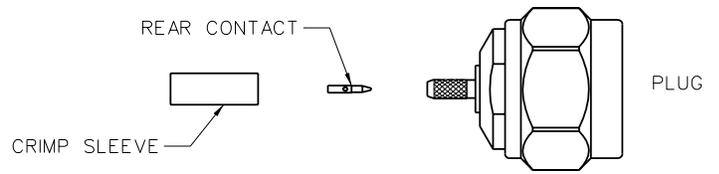

Cable Group	Part No.	Crimp Sleeve Hex Size	Contact Crimp
RG-316/U, 161, 174, 188	138-4403-007	.128 (3.25)	8 INDENT
RG-316 DS, 188 DS	138-4404-007	.151 (3.84)	8 INDENT

	Assembly
Tool	138-4403/4404-007
Crimp Frame	140-0000-967
Die Set	140-0000-990
Contact Tool	140-0000-970
Positioner	140-0000-971

Type N Right Angle Plug Crimp Style for RG-316, 316DX, 58, and 142 Flexible Cable

1. Identify connector parts. (3 piece parts)
2. Strip cable to dimensions shown. Do not nick center conductor. A wire stripper of correct size is recommended for this step. Twist stranded center conductor into tight bundle and tin (optional). Slide crimp sleeve onto jacket of cable.
3. Flare braid and slide plug connector assembly over cable dielectric and under braid. Make sure cable dielectric bottoms against plug contact as shown. Solder center conductor to contact through rear access port. Use a minimum amount of solder for a full fillet joint.
4. Arrange braid uniformly around crimp stem. Slide crimp sleeve forward and crimp using Johnson ergonomic hand crimp frame 140-0000-967 with recommended hex size die set. Screw end cap into access port.

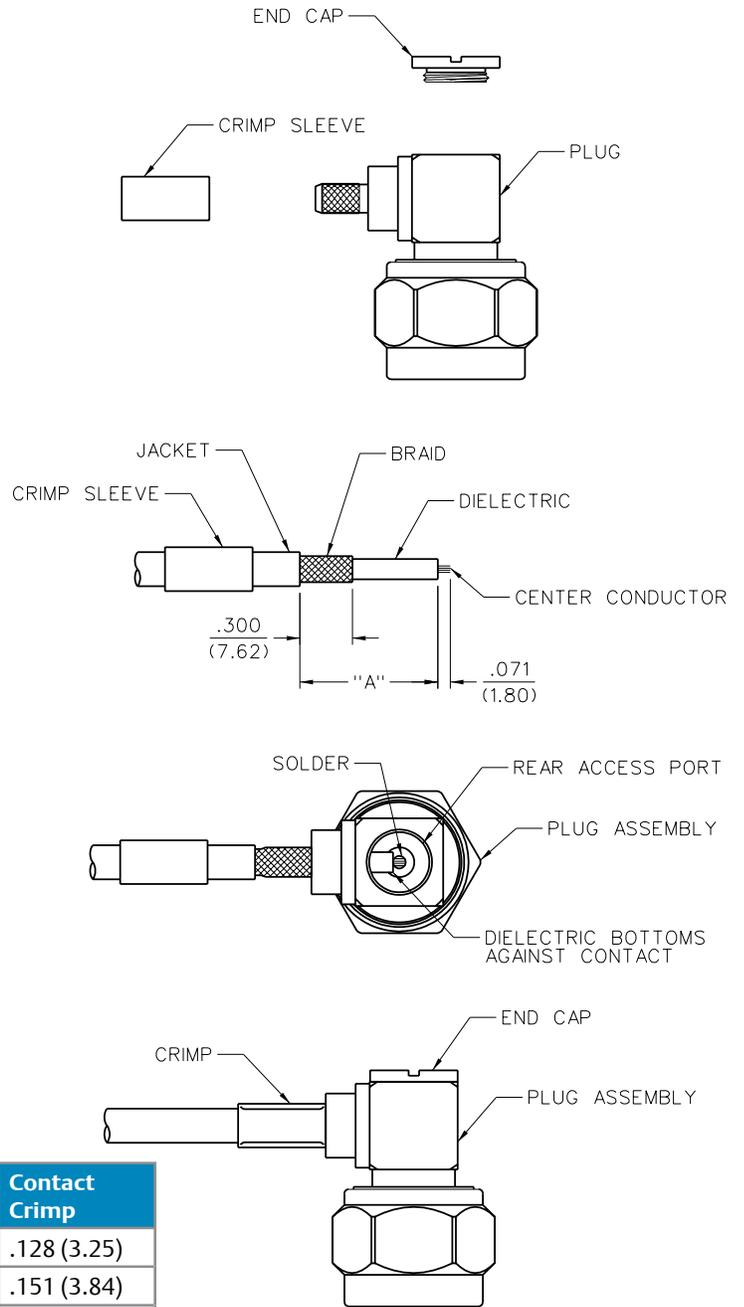

Cable Group	Part No.	Crimp Sleeve Hex Size	Contact Crimp
RG-316/U, 161, 174, 188	138-4403-107	.755 (19.18)	.128 (3.25)
RG-316 DS, 188 DS	138-4404-107	.755 (19.18)	.151 (3.84)
RG-58/U, 141, 303	138-4407-107	.788 (20.02)	.213 (5.41)
RG-55/U, 142, 223, 400	138-4408-107	.788 (20.02)	.213 (5.41)

Assembly	
Tool	138-4403/4404/4407/4408-107
Crimp Frame	140-0000-967
Die Set	140-0000-990

Type N Straight Plug Solder Style for Semi-Rigid Cable

1. Identify connector parts (2 piece parts) and tools (5 piece parts).
2. Strip cable jacket and dielectric to dimension shown. Do not nick center conductor. Clean all debris from cable.
3. Place plug contact onto center conductor, insert appropriate sized solder shim between cable jacket and contact.
4. Insert contact into location fixture and clamp cable in vise. Tighten stop screw until light pressure is applied between contact, solder shim and cable jacket.
5. Solder contact to center conductor through solder hole using .020 (.051) diameter flux core solder wire. Use a minimum amount of solder for a good joint.
6. After solder joint has cooled, loosen stop screw and remove solder shim. Remove cable from vise and remove any excess solder from contact with a sharp blade and clean all debris from contact and cable.
7. Insert contact and cable into plug connector assembly, making sure cable jacket bottoms out against internal shoulder of connector assembly. Insert location fixture into connector assembly and clamp cable in vise. Tighten stop screw until light pressure is applied between connector assembly and cable jacket.
8. Solder connector body to cable jacket, using a minimum amount of solder for a full fillet joint. Allow assembly to cool before removing connector from vise.

Cable Group	Part No.	"A"
RG-405, .086 Semi-Rigid	138-4693-001	.085 (2.16)
RG-402, .141 Semi-Rigid	138-4694-001	.085 (2.16)
RG-401, .250 Semi-Rigid	138-4696-001	.100 (2.54)

Assembly			
Tool	138-4693-001	138-4694-001	138-4696-001
Solder Shim	140-0000-984	140-0000-984	140-0000-985
Location Fixture	140-0000-983	140-0000-983	140-0000-983
Cable Vise	140-0000-962	140-0000-962	140-0000-962
Clamp Inserts	140-0000-964	140-0000-986	

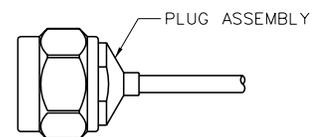
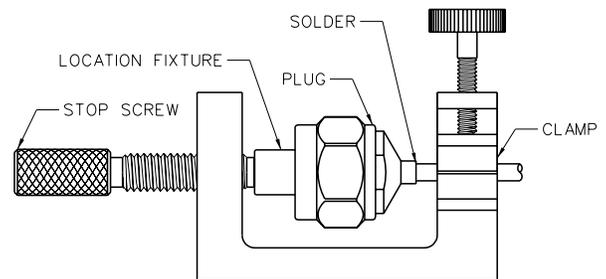
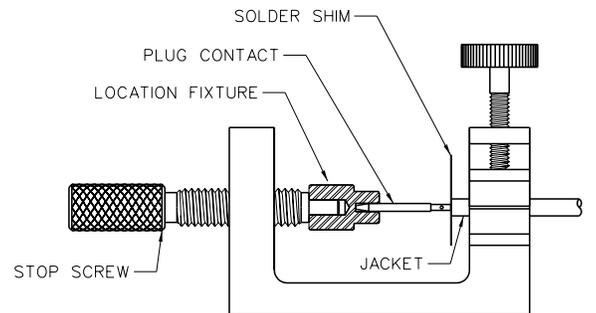
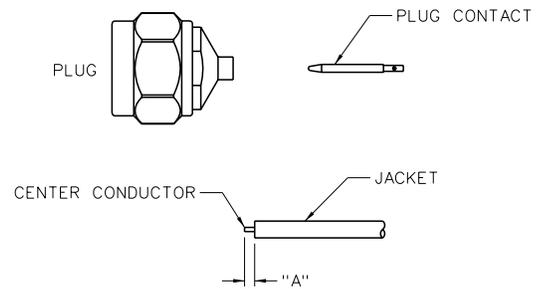
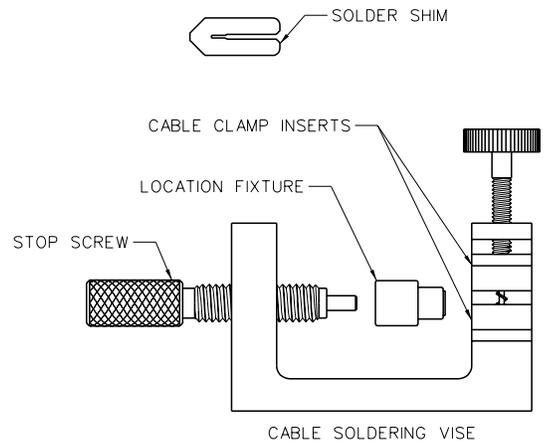

Type N Bulkhead Jack Crimp Style for RG-316 and 316DS Flexible Cable

1. Identify connector parts. (6 piece parts)
2. Strip cable to dimensions shown. Do not nick center conductor. A wire stripper of correct size is recommended for this step. Tin center conductor if contact will be solder attached. Do not tin center conductor if contact will be crimp attached. Slide crimp sleeve onto jacket of cable.
3. Assemble rear contact onto cable as shown. Rear contact should butt against cable dielectric during attachment.

Solder Attachment: Solder rear contact to center conductor through solder hole using .020 (.051) diameter flux core solder wire. Use a minimum amount of solder for a good joint.

Crimp Attachment: Crimp rear contact to center conductor using Johnson indent hand tool 140-0000-970. Crimp location should be centered between end of rear contact and solder hole using positioning tool 140-0000-971. Crimp attachment to solid center conductor cables is not recommended.
4. Flare braid and slide bulkhead jack connector assembly over rear contact and under braid. Rear contact must engage fully with internal captivated jack contact. Cable jacket should be located near end of crimp stem when contacts are fully engaged.
5. Arrange braid uniformly around crimp stem. Slide crimp sleeve forward and crimp using Johnson ergonomic hand crimp frame 140-0000-967 with recommended hex size die set. Maintain forward pressure on cable while crimping.
6. Add gasket, lock washer and mounting nut when installing.

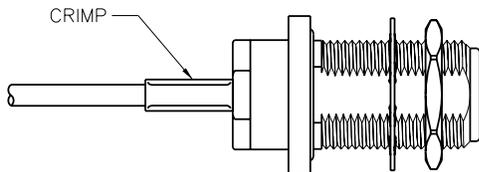
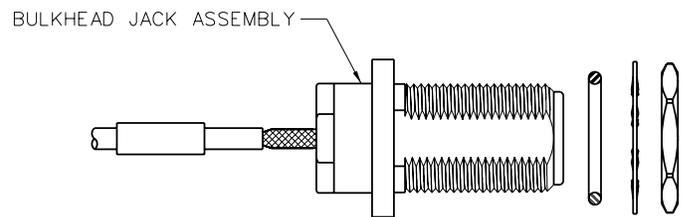
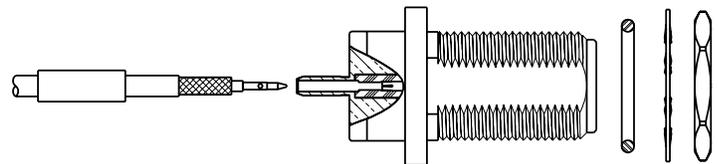
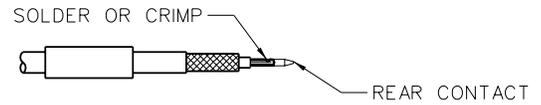
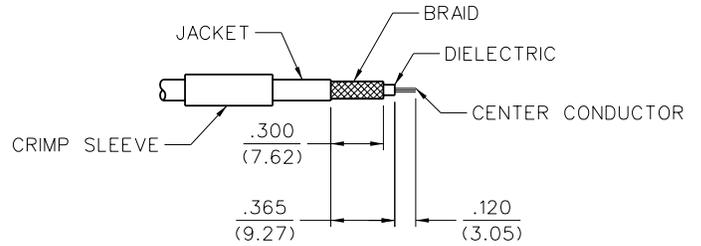
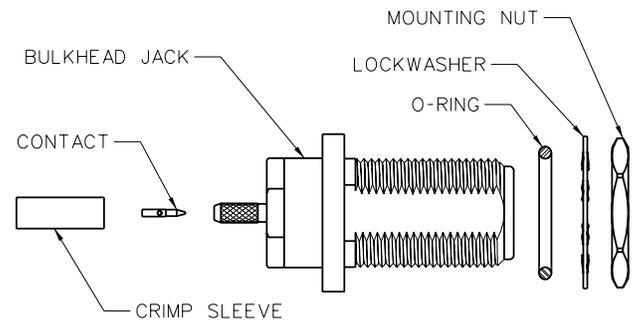

Cable Group	Part No.	Crimp Sleeve Hex Size	Contact Crimp
RG-316/U, 161, 174, 188	138-4303-407	.128 (3.25)	8 INDENT
RG-316 DS, 188 DS	138-4304-407	.151 (3.84)	8 INDENT

	Assembly
Die Set	140-0000-990
Contact Tool	140-0000-970
Positioner	140-0000-971

Type N Bulkhead Jack Solder Style for Semi-Rigid Cable (cont'd from last page)

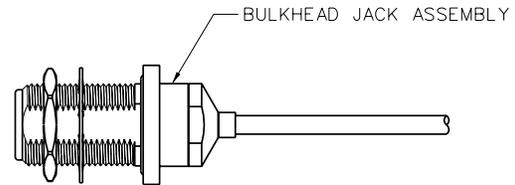
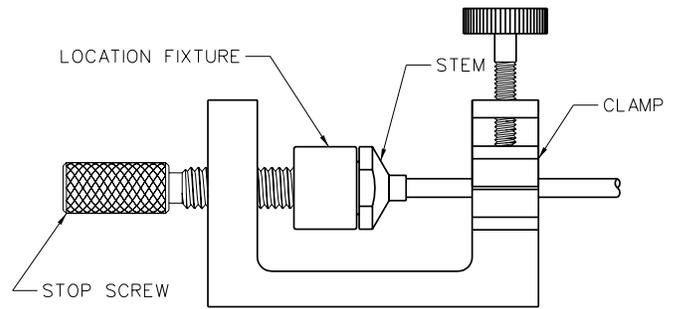
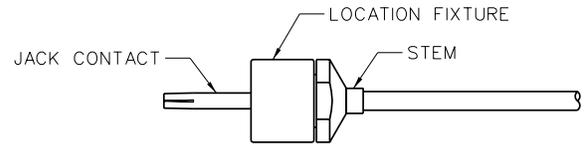
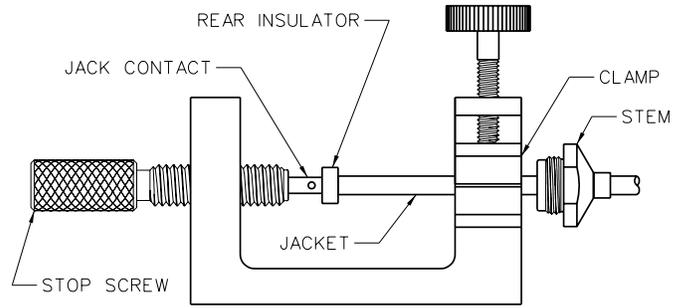

Cable Group	Part No.
RG-405, .086 Semi-Rigid	138-4593-401
RG-402, .141 Semi-Rigid	138-4594-401
RG-401, .250 Semi-Rigid	138-4596-401

Assembly			
Tool	138-4593-401	138-4594-401	138-4596-401
Stop Screw	140-0000-972	140-0000-972	140-0000-972
Cable Vise	140-0000-962	140-0000-962	140-0000-962
Clamp Inserts	140-0000-964	140-0000-965	140-0000-986
Location Fixture	140-0000-987	140-0000-988	140-0000-989

Crimp Type Straight Cable Termination for Flexible Cable

1. Identify connector parts. (2 piece parts)
2. Strip cable to dimensions shown. Do not nick braid or center conductor. A wire stripper of correct size is recommended for this step. Twist stranded center conductor into tight bundle and tin. Slide crimp sleeve onto cable as shown.
3. Flare braid and slide cable into body making certain that the cable insulation is flush with bottom of connector.
4. Arrange braid uniformly around crimp stem. Slide crimp sleeve over braid and crimp securely using recommended crimp tool.

Cable Group	Part No.	"A"	Crimp Hex
RG-178/U, 196	142-0002-221/226	.259 (6.58)	.105 (2.67)
RG-316/U, 161, 174, 179, 187, 188	142-0003-201/206	.312 (7.92)	.128 (3.25)
	142-0003-231/236	.259 (6.58)	.128 (3.25)
	142-0003-241/246	.259 (6.58)	.128 (3.25)
RG-316 DS, 188 DS	142-0004-201/206	.312 (7.92)	.151 (3.83)
	142-0004-211/216	.259 (6.58)	.151 (3.83)
	142-0004-221/226	.259 (6.58)	.151 (3.83)

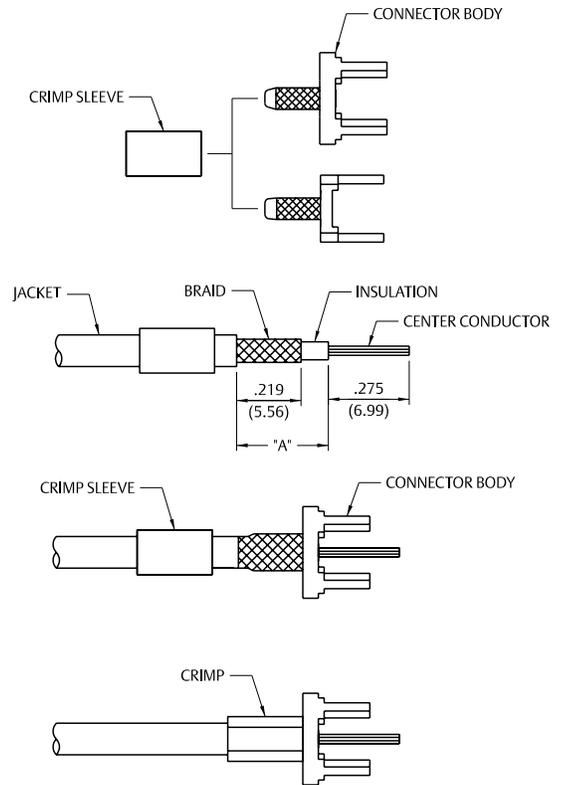

Crimp Type Right Angle Cable Termination for Flexible Cable

1. Identify connector parts. (2 piece parts)
2. Strip cable to dimensions shown. Do not nick braid or center conductor. A wire stripper of correct size is recommended for this step. Twist stranded center conductor into tight bundle and tin. Slide crimp sleeve onto cable as shown.
3. Flare braid and slide cable into body making certain that the cable insulation is flush with bottom of connector body.
4. Arrange braid uniformly around crimp stem. Slide crimp sleeve over braid and crimp securely using recommended crimp tool.

Cable Group	Part No.	Crimp Hex
RG-316/U, 161, 174, 179, 187, 188	142-0003-301/306	.128 (3.25)
RG-316 DS, 188 DS	142-0004-301/306	.151 (3.83)

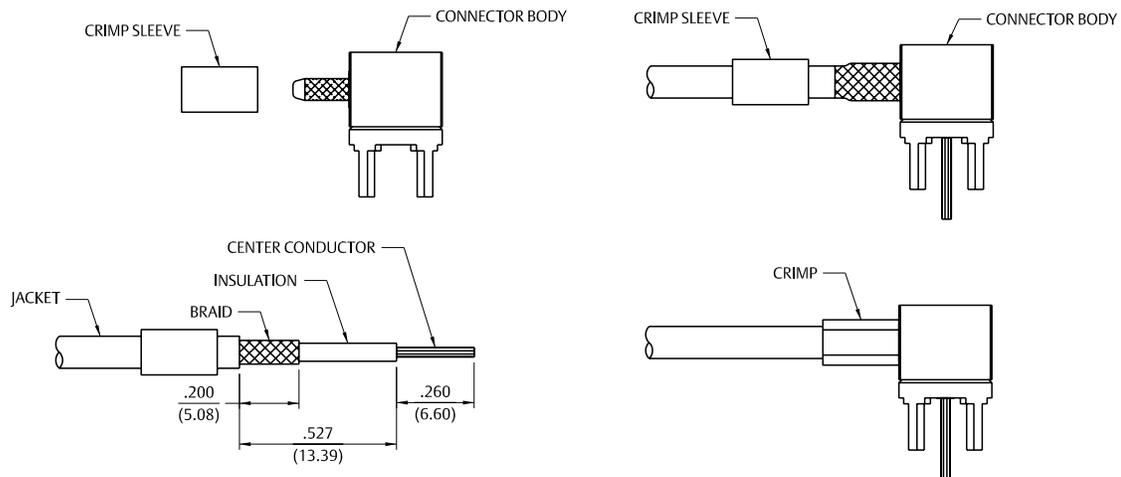

Solder Type Straight Cable Termination for End Launch Surface Mount

1. Identify connector parts. (2-piece parts)
2. Strip cable to dimensions shown. Do not nick braid or center conductor. A wire stripper of correct size is recommended for this step. Twist stranded center conductor into tight bundle and tine. Slide crimp sleeve onto cable as shown.
3. Flare braid and slide cable into body making certain that the cable dielectric is flush with the end of the connector body.
4. Arrange braid uniformly around crimp sleeve. Slide crimp sleeve over braid and crimp securely using recommended crimp tool.

Cable Group	Part No.	Crimp Hex
RG-178/U, 196	142-0002-821	.105 (2.67)

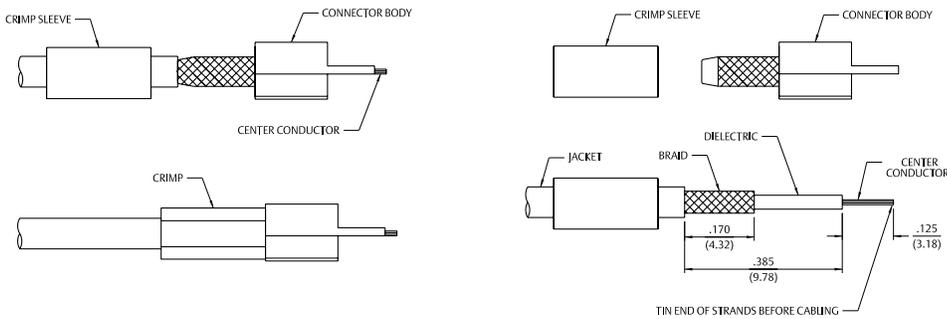

kwiQMAte™ Straight Plugs for Flexible Cable – Crimp or Solder Contacts

1. Identify connector parts. (3 piece parts)
2. Strip cable to dimensions shown. Do not nick braid or center conductor. Tin center conductor if contact will be solder attached. Do not tin center conductor if contact is to be crimp attached. Slide heat shrink (as applicable) and crimp sleeve onto jacket of cable.
3. Assemble contact onto cable as shown.

Solder Attachment: Solder contact to center conductor through solder hole using .020 (0.51) diameter solder. Use a minimum amount of solder for a good joint.

Crimp Attachment: Crimp contact to center conductor using Johnson® Hand Tool 144-0000-910, setting #2. Crimp location should be centered between end of contact and X-hole. Crimp attachment to solid center conductor cables is not recommended.
4. Flare braid and slide body assembly over contact and under braid. Then seat body assembly firmly onto contact. The cable may have to be held in a clamping fixture. Arrange braid uniformly around crimp stem. Slide crimp sleeve forward and crimp using recommended crimp tool. Slide heat shrink forward and shrink (as applicable).

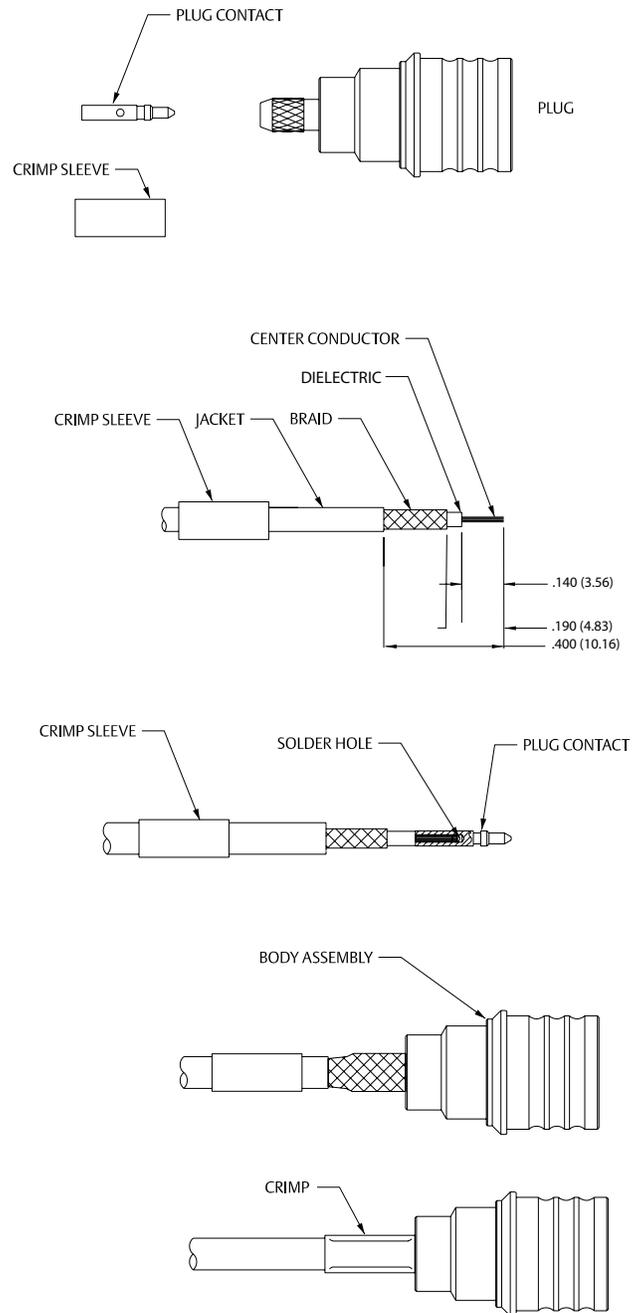

Cable Type	Part No.	Crimp Hex
RG-316	146-0403-007	.128 (3.25)
RG-316 DS	146-0404-007	.151 (3.83)

Horizontal Test Jacks – For Test Points

Insulated Miniature



Silver Plating	
Part No.	Color
105-1101-001	White
105-1102-001	Red
105-1103-001	Black
105-1104-001	Green
105-1107-001	Yellow

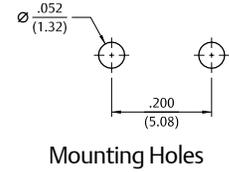
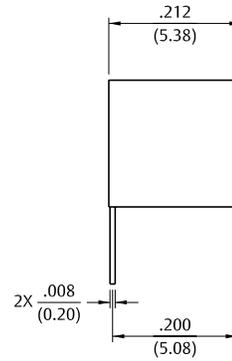
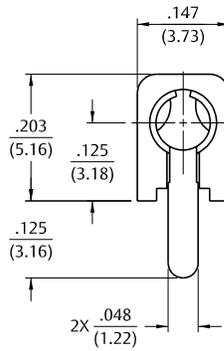

SPECIFICATIONS

Contact: Copper aluminum alloy*

Finish: Silver

Body: Nylon 6/6 per ASTM D4066

RATINGS

Current: 5 amps

Breakdown Voltage: 2100 VRMS minimum

Contact Resistance: 0.010 ohms maximum

Adjacent Jack C: 1 pF maximum at 1 MHz

For Standard Tip Plug:

.080 (2.00) Diameter

FEATURES

- Contact protected from flux and solder
- Probe access from both ends
- Nylon UL approved for self extinguishing

*A new material development that, for this application, meets or exceeds beryllium copper.

Insulated Standard



Silver Plating	
Part No.	Color
105-0751-001	White
105-0752-001	Red
105-0753-001	Black
105-0754-001	Green
105-0756-001	Orange
105-0757-001	Yellow
105-0758-001	Brown
105-0760-001	Blue
105-0762-001	Violet
105-0763-001	Gray

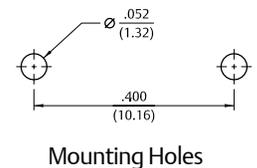
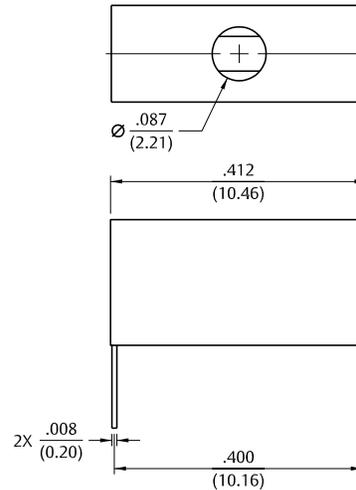
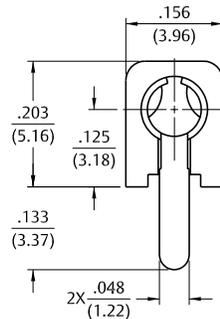

SPECIFICATIONS

Contact: Copper aluminum alloy*

Finish: Silver

Body: Nylon 6/6 per ASTM D4066

RATINGS

Current: 5 amps

Breakdown Voltage: 2100 VRMS minimum

Contact Resistance: Silver: 0.010 ohms maximum

Adjacent Jack C: 1 pF maximum at 1 MHz

For Standard Tip Plug:

.080 (2.00) Diameter

FEATURES

- Contact protected from flux and solder
- Probe access from both ends
- Nylon UL approved for self extinguishing

*A new material development that, for this application, meets or exceeds beryllium copper.

Tip Jacks – For Connections to Test Equipment, Power Supplies, and Electronic Instrumentation

Insulated Metal Clad: Military Type



Gold Plating Part No. to Mil-Spec. Part No. Cross Reference

Part No.	Color	Mil-C-39024/10
105-0201-200	White	-01
105-0202-200	Red	-02
105-0203-200	Black	-03

SPECIFICATIONS

Contact: Brass per QQ-B-626D with wrap around beryllium copper spring per QQ-C-533

Finish: Gold

Body: Nylon 6/6 per ASTM D4066

Threaded Brass Jacket: Per QQ-B-626D, nickel

Hardware: Nickel plated washer and nut (unassembled)

Panel Thickness: Up to .218 (5.45)

RATINGS

Current: 10 amps

Breakdown Voltage: 5700 VRMS minimum

Contact Resistance: 0.004 ohms maximum

Contact-To-Panel C: 2 pF nominal

Manufactured to meet MIL-C-39024/10

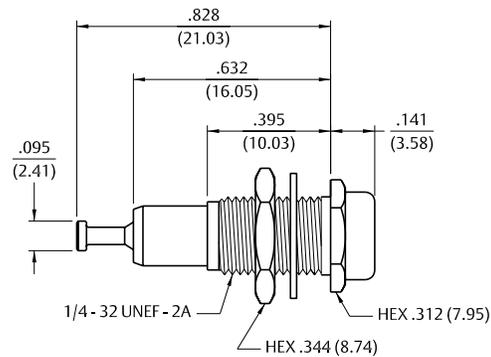

For Standard Tip Plug: .080 (2.00) Diameter

FEATURES

- Machined contact with turret terminal
- For military or industrial applications
- Closed entry blocks access of probes greater than .085 (2.16)
- Nylon UL approved for self extinguishing

† Avoid user injury due to misapplication. See safety advisory definitions inside front cover.

Insulated Metal Clad: Standard Type



Silver Plating

Part No.	Color
105-0251-001	White
105-0252-001	Red
105-0253-001	Black

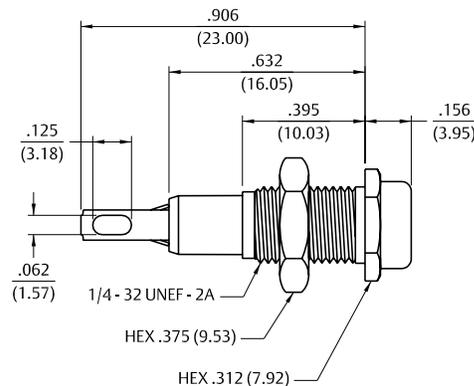

SPECIFICATIONS

Contact: Phosphor bronze per QQ-B-750

Finish: Silver

Body: Nylon 6/6 per ASTM D4066

Panel Thickness: Up to .281 (7.10)

RATINGS

Current: 10 amps

Breakdown Voltage: 5700 VRMS minimum†

Contact Resistance: 0.010 ohms maximum

Contact-To-Panel C: 2 pF nominal

For Standard Tip Plug: .080 (2.00) Diameter

FEATURES

- Formed contact with slotted terminal
- Nylon UL approved for self extinguishing

† Avoid user injury due to misapplication. See safety advisory definitions inside front cover.

Tip Jacks – For Connections to Test Equipment, Power Supplies, and Electronic Instrumentation

Insulated Metal Clad: Military Type



Silver Plating	
Part No.	Color
105-0701-001	White
105-0702-001	Red
105-0703-001	Black

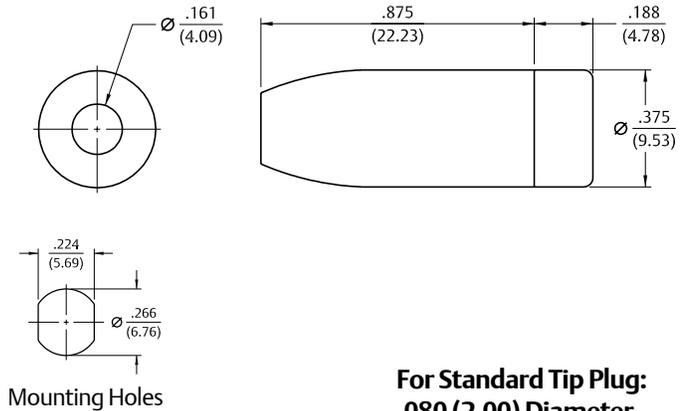

SPECIFICATIONS

Contact: Brass per QQ-B-626D with wrap around beryllium copper spring per QQ-C-533

Finish: Silver

Body: Nylon 6/6 per ASTM D4066

Threaded Brass Jacket: Per QQ-B-626D, nickel

Hardware: Nickel plated washer and nut (unassembled)

Panel Thickness: Up to .218 (5.45)

RATINGS

Current: 10 amps

Breakdown Voltage: 5700 VRMS minimum

Contact Resistance: 0.004 ohms maximum

Contact-To-Panel C: 2 pF nominal

Manufactured to meet MIL-C-39024/10

For Standard Tip Plug: .080 (2.00) Diameter FEATURES

- Machined contact with turret terminal
- For military or industrial applications
- Closed entry blocks access of probes greater than .085 (2.16)
- Nylon UL approved for self extinguishing

† Avoid user injury due to misapplication. See safety advisory definitions inside front cover.

Insulated Metal Clad: Standard Type



Nickel Plating	
Solder Type Up to 16 Gauge Part No.	Crimp Type 16 Gauge Plating Color
105-0771-001	White
105-0772-001	Red
105-0773-001	Black

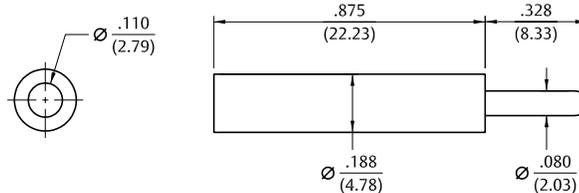

SPECIFICATIONS

Contact: Brass per QQ-B-626D

Finish: Nickel

Insulated Handle: Nylon 6/6 per ASTM D4066

RATINGS

Current: 10 amps

Breakdown Voltage: 3500 VRMS minimum†

Contact Resistance: 0.010 ohms maximum

For Standard Tip Plug: .080 (2.00) Diameter FEATURES

- Solder or crimp type connection
- Accepts wire sizes up to 16 gauge
- Nylon UL approved for self extinguishing
- Designed for use with horizontal and vertical test jacks only

† Avoid user injury due to misapplication. See safety advisory definitions inside front cover.

Banana Jacks – For Test Equipment and Power Supplies

Uninsulated Standard Type: Slotted Lug Terminal



Nickel Plating	
Part No.	Color
108-0740-102	Nickel

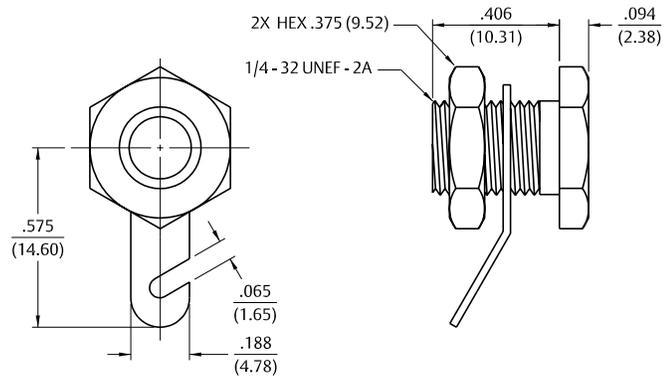

SPECIFICATIONS

Jack Body: Brass per QQ-B-626D
Finish: Nickel
Hardware: Nickel plated nut; stamped tin plated solder terminal (unassembled)
Panel Thickness: Up to .250 (6.35)

RATINGS

Current: 15 amps
Contact Resistance: 0.010 ohms maximum

For Standard Banana Plug:

.175 (4.44) Across Flats

FEATURES

- Accepts up to 12 gauge wire
- Hex head for faster installation
- For higher current designs

Insulated Rib-Loc™ Solder Terminal



Bright Tin Plating	
Part No.	Color
108-2301-801	White
108-2302-801	Red
108-2303-801	Black
108-2307-801	Yellow
108-2310-801	Blue

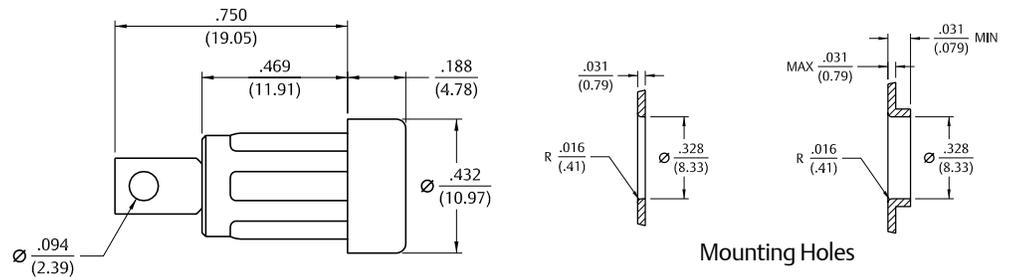

SPECIFICATIONS

Contact: Formed brass per QQ-B-626D
Finish: Bright Tin
Body: Nylon 6/6 per ASTM D4066
Panel Thickness: Up to .250 (6.35)

RATINGS

Current: 15 amps
Breakdown Voltage: 7000 VRMS minimum†
Contact Resistance: 0.010 ohms maximum
Contact-To-Panel C: 2.4 pF nominal

For Standard Banana Plug:

.175 (4.44) Across Flats

FEATURES

- Requires no mounting hardware
- Accepts up to 16 gauge wire
- Nylon UL approved for self extinguishing

† Avoid user injury due to misapplication. See safety advisory definitions inside front cover.

Banana Jacks & Plugs – For Test Equipment and Power Supplies

Insulated Pierced Lug Terminal



Nickel Plating	
Part No.	Color
108-0745-001	Red
108-0745-002	Black

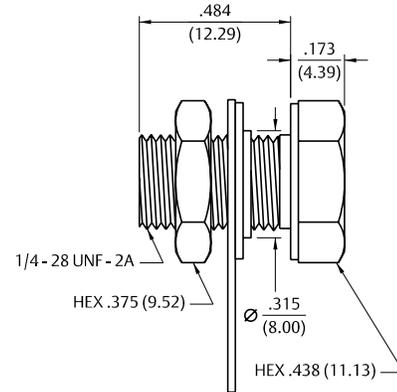
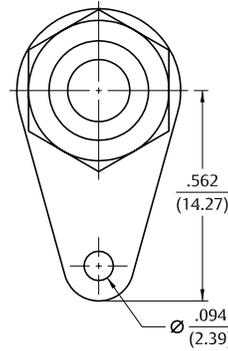

SPECIFICATIONS

Contact:	Brass per QQ-B-626D
Finish:	Nickel
Hex Head:	Molded phenolic
Hardware:	Nickel plated nut, fiber insulating washer and stamped tin plated solder terminal (unassembled)
Panel Thickness:	Up to .281 (7.15)

RATINGS

Current:	15 amps
Breakdown Voltage:	1500 VRMS minimum†
Contact Resistance:	0.010 ohms maximum
Contact-To-Panel:	2.4 pF nominal

For Standard Banana Plug: .175 (4.44) Across Flats

FEATURES

- Withstands extreme temperatures and abuse
- Stamped tin plated solder terminal with hole for up to 12 gauge wire
- Integrally molded hex head for fast installation

† Avoid user injury due to misapplication. See safety advisory definitions inside front cover.

Uninsulated Rivet Type



Silver Plating	
Part No.	Color
108-0754-001	Silver

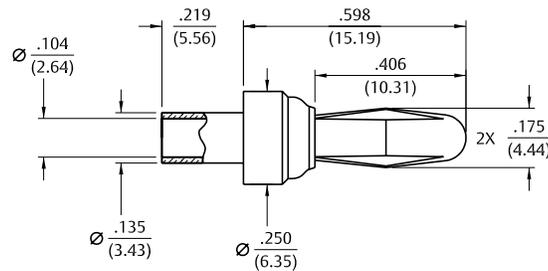

SPECIFICATIONS

Plug Body:	Brass per QQ-B-626D
Plug Spring:	Beryllium copper per QQ-C-533
Finish:	Silver
Panel Thickness:	Up to .156 (4.00)

RATINGS

Current:	15 amps
Contact Resistance:	0.010 ohms maximum

For Standard Banana Plug: .166 (4.23) Diameter

FEATURES

- Shorter spring adapts to standard jack or special size jack
- Ideal for limited space applications

Banana Plugs – For Test Equipment and Power Supplies

Insulated Solderless Tapered Handle



Nickel Plating	
Part No.	Color
108-0301-001	White
108-0302-001	Red
108-0303-001	Black
108-0304-001	Green
108-0306-001	Orange
108-0307-001	Yellow
108-0308-001	Brown
108-0310-001	Blue
108-0312-001	Violet
108-0313-001	Gray

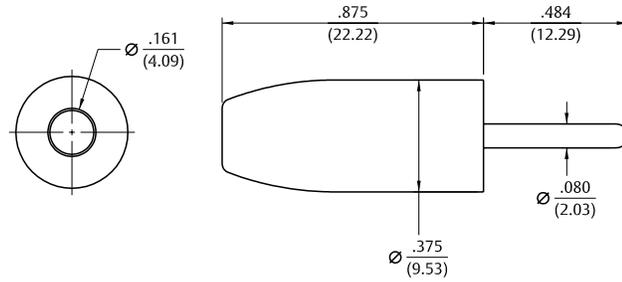

SPECIFICATIONS

Plug Body: Brass per QQ-B-626D
Plug Spring: Nickel silver per QQ-C-533
Finish: Nickel
Insulated Handle: Nylon 6/6 per ASTM D4066

Panel Thickness: Up to .281 (7.15)

RATINGS

Current: 15 amps
Breakdown Voltage: 3500 VRMS minimum†
Contact Resistance: 0.010 ohms maximum

For Standard Banana Plug: .166 (4.23) Diameter

FEATURES

- Fast solderless connection of up to 16 gauge wire
- Recessed plug body to limit shock hazard
- Nylon UL approved for self extinguishing

† Avoid user injury due to misapplication. See safety advisory definitions inside front cover.

Insulated Side Set Screw Solderless



Nickel Plating	
Part No.	Color
108-1702-101	Red
108-1703-101	Black

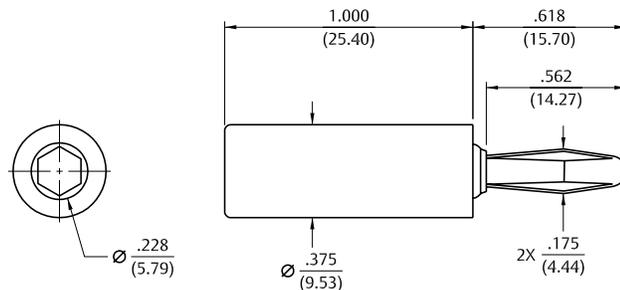

SPECIFICATIONS

Plug Body: Brass per QQ-B-626D
Plug Spring: Nickel silver per QQ-C-585
Finish: Nickel
Insulated Handle: Nylon 6/6 per ASTM D4066

RATINGS

Current: 15 amps
Breakdown Voltage: 35 VRMS minimum†

For Standard Banana Plug: .166 (4.23) Diameter For Low Voltage (50 WVDC) Applications

FEATURES

- Fast solderless connection of up to 16 gauge wire
- Set screw for dependable connections with low voltage
- Nylon UL approved for self extinguishing

† Avoid user injury due to misapplication. See safety advisory definitions inside front cover.

Banana Plugs – For Test Equipment and Power Supplies

Insulated Stacking Single Type



Nickel Plating	
Part No.	Color
108-1081-001	White
108-1082-001	Red
108-1083-001	Black
108-1087-001	Yellow

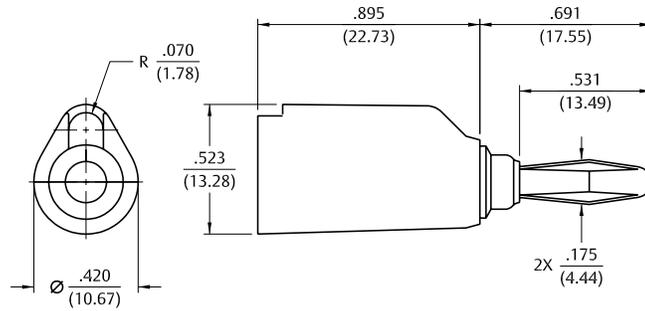

SPECIFICATIONS

Plug Body: Brass per QQ-B-626D
Plug Spring: Nickel silver per QQ-C-585
Finish: Nickel
Insulated Handle: Nylon 6/6 per ASTM D4066

Panel Thickness: Up to .281 (7.15)

RATINGS

Current: 15 amps
Breakdown Voltage: 3500 VRMS minimum†
Contact Resistance: 0.010 ohms maximum

For Standard Banana Plug:

.166 (4.23) Diameter

FEATURES

- Wire can be soldered to threaded stud
- Solder stud accepts up to 16 gauge wire
- Nylon UL approved for self extinguishing

† Avoid user injury due to misapplication. See safety advisory definitions inside front cover.

Insulated Stacking Dual Type



Nickel Plating Set Screw (Accepts Wire Sizes Up To 14 Gauge)	
Part No.	Color
108-0252-001	Red
108-0253-001	Black

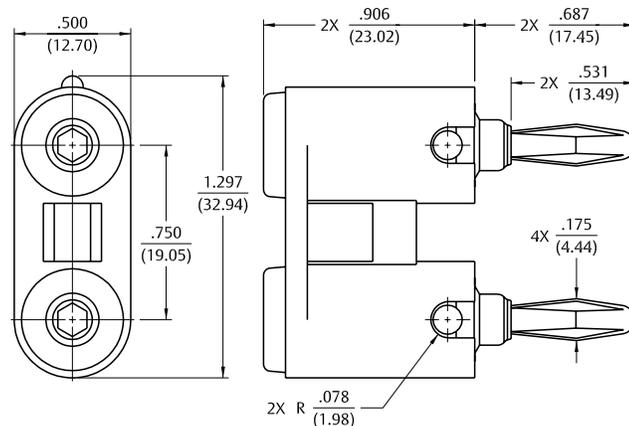

SPECIFICATIONS

Plug Body: Brass per QQ-B-626D
Plug Spring: Nickel silver per QQ-C-586
Finish: Nickel
Insulated Handle: Nylon 6/6 per ASTM D4066

RATINGS

Current: 15 amps
Breakdown Voltage: 3500 VRMS minimum†
Contact Resistance: 0.010 ohms maximum

For Standard Banana Plug:

.166 (4.23) Diameter

FEATURES

- Accepts standard banana plug from rear
- Built-in strain relief for long life
- Nylon UL approved for self extinguishing

† Avoid user injury due to misapplication. See safety advisory definitions inside front cover.

Binding Posts – For Audio Circuitry and RF Circuitry

Insulated Standard



Silver Plating	
Part No.	Color
111-0101-001	White
111-0102-001	Red
111-0104-001	Green
111-0103-001	Black
111-0107-001	Yellow
111-0110-001	Blue

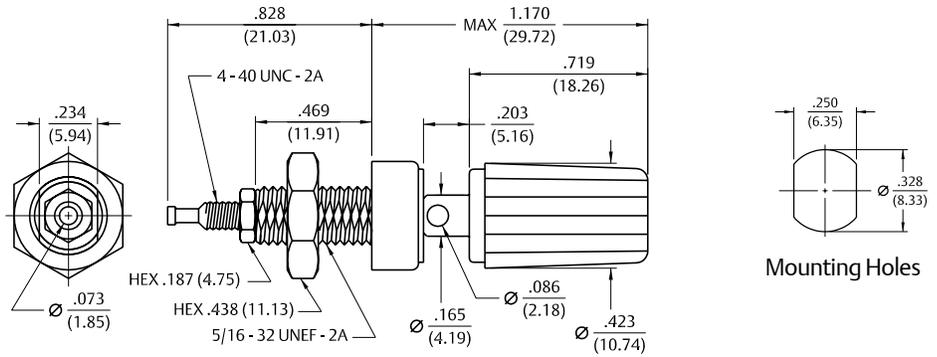

SPECIFICATIONS

Stud: Brass per QQ-B-626D

Finish: Silver

Insulating Material: Nylon 6/6 per ASTM D4066

Hardware: Nickel plated nut (unassembled)

Body Thread Stripping Torque: 6.0 lb. in. (7.0 kg cm)

Panel Thickness: Up to .281 (7.15)

RATINGS

Current: 15 amps

Contact Resistance: 0.010 ohms maximum

Breakdown Voltage: 5700 VRMS minimum†

Stud-To-Panel: 3.3 pF nominal

For Standard Banana Plug:

.175 (4.44) Diameter

FEATURES

- Turret terminal
- Captive thumb nut
- Insulated body is flatted to prevent turning
- Nylon UL approved for self-extinguishing

† Avoid user injury due to misapplication. See safety advisory definitions inside front cover.

Insulated Standard With – Thumb Nut – Grounded Type



Nickel Plating	
Part No.	Color
111-0702-001	Red
111-0703-001	Black

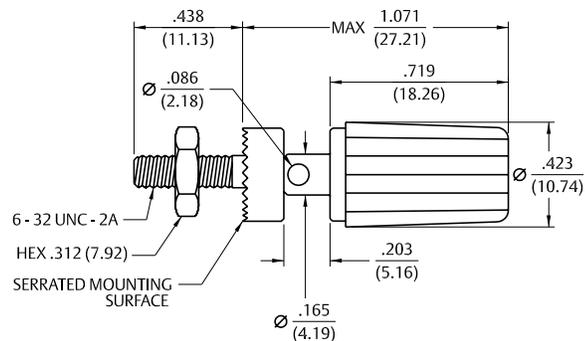

SPECIFICATIONS

Stud: Brass per QQ-B-626D

Finish: Nickel

Insulating Material: Nylon 6/6 per ASTM D4066

Hardware: Nickel plated nut (unassembled)

Panel Thickness: Up to .313 (7.95)

RATINGS

Current: 15 amps

For Standard Banana Plug:

.166 (4.23) Diameter

FEATURES

- Accepts standard banana plug from rear
- Built-in strain relief for long life
- Nylon UL approved for self-extinguishing

† Avoid user injury due to misapplication. See safety advisory definitions inside front cover.

Table of Contents

Part Number and Competitor Cross-Reference Index

Other Information	
Assembly Tools	185
Capabilities	190
Cable Information	192
Assembly Instruction	193
Mounting Hole Layouts	194
Numerical Index	274
Competitor Cross Reference	280

3	MMCX Connectors
13	MCX Connectors
39	SMK Connectors
45	SMA Connectors
103	SMB Connectors
131	SMC Connectors
137	SMP Connectors
145	Type N Connectors
153	Shielded Cable Terminations
157	Between-Series Adapters
161	Fixed Length Cable Assemblies
173	Ultra Miniature Connectors (UMC)
181	kwiQMate™ Connectors
185	Tools
193	Assembly Instructions
257	Electronic Hardware
274	Index

While every precaution has been taken to ensure accuracy and completeness herein, Emerson Network Power Connectivity Solutions assumes no responsibility, and disclaims all liability for damages resulting from use of this information or for any errors or omissions. Specifications subject to change without notice.

Part Number Index

131-8701-606.....	127	133-3433-001.....	207	133-5402-106.....	26	134-1019-371.....	180	138-4403-007.....	150
131-8701-811.....	128	133-3433-006.....	16	133-5402-106.....	210	134-1019-381.....	180	138-4403-007.....	243
131-8701-821.....	128	133-3433-006.....	207	133-5403-001.....	26	134-1068-001.....	34	138-4403-107.....	150
131-8701-841.....	127	133-3433-101.....	17	133-5403-001.....	207	134-1068-011.....	34	138-4403-107.....	245
131-8701-846.....	127	133-3433-101.....	210	133-5403-006.....	26	134-1068-021.....	35	138-4404-007.....	150
131-8711-201.....	126	133-3433-106.....	17	133-5403-006.....	207	134-1068-031.....	35	138-4404-007.....	243
131-8711-202.....	126	133-3433-106.....	210	133-5403-101.....	26	134-1069-001.....	130	138-4404-107.....	150
131-8801-801.....	128	133-3693-001.....	16	133-5403-101.....	210	134-1069-011.....	130	138-4404-107.....	245
131-8801-811.....	128	133-3693-001.....	206	133-5403-106.....	26	134-1069-021.....	130	138-4407-007.....	150
131-8801-821.....	128	133-3693-006.....	16	133-5403-106.....	210	134-1069-031.....	130	138-4407-007.....	244
131-8901-401.....	129	133-3693-006.....	206	133-5404-001.....	26	135-3302-001.....	7	138-4407-107.....	150
131-8901-406.....	129	133-3693-101.....	16	133-5404-001.....	207	135-3302-001.....	205	138-4407-107.....	245
131-8901-801.....	129	133-3693-101.....	206	133-5404-006.....	26	135-3302-401.....	7	138-4408-007.....	150
131-8901-811.....	129	133-3693-106.....	16	133-5404-006.....	207	135-3302-401.....	205	138-4408-007.....	244
131-8901-821.....	129	133-3693-106.....	206	133-5404-101.....	26	135-3303-001.....	7	138-4408-107.....	150
131-9403-001.....	118	133-3701-201.....	18	133-5404-101.....	210	135-3303-001.....	204	138-4408-107.....	245
131-9403-001.....	235	133-3701-206.....	18	133-5404-106.....	26	135-3304-001.....	7	138-4416-007.....	150
131-9403-021.....	118	133-3701-211.....	18	133-5404-106.....	210	135-3304-001.....	204	138-4416-007.....	244
131-9403-021.....	232	133-3701-216.....	18	133-5701-201.....	27	135-3333-001.....	7	138-4416-107.....	150
131-9403-101.....	118	133-3701-221.....	18	133-5701-206.....	27	135-3333-001.....	204	138-4416-107.....	246
131-9403-101.....	237	133-3701-226.....	18	133-5701-801.....	27	135-3336-001.....	7	138-4418-007.....	150
131-9403-101.....	239	133-3701-231.....	19	133-5701-806.....	27	135-3336-001.....	205	138-4418-007.....	244
131-9403-116.....	237	133-3701-236.....	19	133-8333-001.....	31	135-3336-401.....	7	138-4418-107.....	150
131-9403-116.....	239	133-3701-301.....	20	133-8333-001.....	209	135-3336-401.....	205	138-4418-107.....	246
131-9404-001.....	118	133-3701-306.....	20	133-8333-401.....	32	135-3402-001.....	7	138-4449-007.....	150
131-9404-001.....	235	133-3701-311.....	20	133-8333-401.....	209	135-3402-001.....	202	138-4449-007.....	244
131-9404-021.....	118	133-3701-316.....	20	133-8334-001.....	31	135-3402-101.....	6	138-4593-401.....	149
131-9404-021.....	232	133-3701-321.....	20	133-8334-001.....	209	135-3402-101.....	200	138-4593-401.....	251
131-9404-101.....	118	133-3701-326.....	20	133-8334-401.....	32	135-3402-111.....	6	138-4594-401.....	149
131-9404-101.....	237	133-3701-401.....	22	133-8334-401.....	209	135-3402-111.....	201	138-4594-401.....	251
131-9404-101.....	239	133-3701-406.....	22	133-8433-001.....	31	135-3403-001.....	7	138-4596-401.....	149
131-9404-116.....	237	133-3701-411.....	22	133-8433-001.....	209	135-3403-001.....	203	138-4596-401.....	251
131-9404-116.....	239	133-3701-416.....	22	133-8433-101.....	31	135-3403-101.....	6	138-4693-001.....	149
131-9701-201.....	119	133-3701-601.....	22	133-8433-101.....	211	135-3403-101.....	201	138-4693-001.....	247
131-9701-211.....	119	133-3701-606.....	22	133-8434-001.....	31	135-3404-001.....	7	138-4693-011.....	149
131-9701-301.....	119	133-3701-611.....	23	133-8434-001.....	209	135-3404-001.....	203	138-4693-011.....	248
133-3302-001.....	17	133-3701-616.....	23	133-8434-101.....	31	135-3404-101.....	6	138-4694-001.....	149
133-3302-001.....	207	133-3701-621.....	23	133-8434-101.....	211	135-3404-101.....	201	138-4694-001.....	247
133-3302-006.....	17	133-3701-626.....	23	133-8445-001.....	31	135-3433-001.....	7	138-4694-011.....	149
133-3302-006.....	207	133-3701-801.....	21	133-8445-001.....	209	135-3433-001.....	203	138-4694-011.....	248
133-3302-401.....	17	133-3701-806.....	21	133-8445-101.....	31	135-3436-001.....	7	138-4696-001.....	149
133-3302-401.....	207	133-3701-811.....	21	133-8445-101.....	211	135-3436-001.....	202	138-4696-001.....	247
133-3302-406.....	17	133-3701-816.....	21	133-8701-201.....	32	135-3436-101.....	6	138-4696-011.....	149
133-3302-406.....	207	133-3701-821.....	21	133-8701-211.....	32	135-3436-101.....	200	138-4696-011.....	248
133-3303-001.....	17	133-3701-826.....	21	133-8701-301.....	33	135-3693-101.....	6	138-4701-407.....	151
133-3303-001.....	207	133-3711-201.....	19	133-8701-311.....	33	135-3693-101.....	198	138-4701-607.....	151
133-3303-006.....	17	133-3711-202.....	19	133-8701-401.....	33	135-3701-201.....	8	138-4901-407.....	152
133-3303-006.....	207	133-3711-211.....	19	133-8701-801.....	33	135-3701-211.....	8	138-4901-807.....	151
133-3303-401.....	17	133-3711-212.....	19	133-8701-831.....	35	135-3701-301.....	8	138-4901-817.....	152
133-3303-401.....	207	133-3711-301.....	20	133-8711-201.....	32	135-3701-311.....	8	138-9408-007.....	241
133-3303-406.....	17	133-3711-302.....	20	133-8711-211.....	32	135-3711-201.....	8	138-9449-007.....	241
133-3303-406.....	207	133-3711-311.....	20	133-8801-201.....	32	135-3711-202.....	8	140-0000-951.....	187
133-3304-001.....	17	133-3711-312.....	20	133-8801-211.....	32	135-3711-801.....	9	140-0000-952.....	187
133-3304-001.....	207	133-3711-801.....	22	133-8801-221.....	32	135-3711-802.....	9	140-0000-953.....	187
133-3304-006.....	17	133-3711-802.....	22	133-8801-831.....	35	135-3801-201.....	9	140-0000-954.....	188
133-3304-006.....	207	133-3801-201.....	18	133-8901-801.....	33	135-3801-811.....	9	140-0000-955.....	187
133-3304-401.....	17	133-3801-206.....	18	133-8901-821.....	34	135-9402-001.....	12	140-0000-956.....	188
133-3304-401.....	207	133-3801-211.....	18	133-9402-101.....	208	135-9402-001.....	205	140-0000-957.....	189
133-3304-406.....	17	133-3801-216.....	18	133-9403-001.....	37	135-9402-111.....	19	140-0000-958.....	189
133-3304-406.....	207	133-3801-801.....	23	133-9403-001.....	207	135-9402-111.....	199	140-0000-959.....	189
133-3402-001.....	16	133-3801-806.....	23	133-9403-101.....	37	135-9403-001.....	12	140-0000-960.....	189
133-3402-001.....	207	133-3801-821.....	23	133-9403-101.....	208	135-9403-001.....	204	140-0000-961.....	189
133-3402-006.....	16	133-3801-826.....	23	133-9403-104.....	208	135-9403-101.....	12	140-0000-962.....	189
133-3402-006.....	207	133-3801-841.....	21	133-9404-001.....	37	135-9403-101.....	199	140-0000-964.....	189
133-3402-101.....	17	133-3801-846.....	21	133-9404-001.....	207	135-9404-001.....	204	140-0000-965.....	189
133-3402-101.....	210	133-3801-851.....	21	133-9404-101.....	37	135-9436-001.....	12	140-0000-968.....	189
133-3402-106.....	17	133-3801-856.....	21	133-9404-101.....	208	135-9436-001.....	205	140-0000-970.....	187
133-3402-106.....	210	133-3901-401.....	23	133-9701-201.....	38	135-9436-101.....	12	140-0000-971.....	187
133-3403-001.....	16	133-3901-406.....	23	133-9701-211.....	38	135-9436-101.....	200	141-0000-901.....	186
133-3403-001.....	207	133-3901-801.....	23	133-9701-231.....	38	135-9701-201.....	12	141-0000-902.....	186
133-3403-006.....	16	133-3901-806.....	23	133-9701-301.....	38	135-9701-211.....	12	141-0000-903.....	186
133-3403-006.....	207	133-5302-401.....	26	133-9701-311.....	38	135-9701-301.....	13	141-0000-904.....	188
133-3403-101.....	17	133-5302-401.....	207	133-9701-801.....	38	135-9701-311.....	13	141-0000-905.....	186
133-3403-101.....	210	133-5302-406.....	26	134-0303-406.....	240	135-9711-801.....	13	141-0000-907.....	187
133-3403-106.....	17	133-5302-406.....	207	134-0304-406.....	240	135-9711-802.....	13	141-0000-908.....	188
133-3403-106.....	210	133-5303-401.....	26	134-0307-406.....	240	138-4303-407.....	150	141-0000-910.....	187
133-3404-001.....	16	133-5303-401.....	207	134-0308-406.....	240	138-4303-407.....	249	141-0000-911.....	186
133-3404-001.....	207	133-5303-406.....	26	134-1012-011.....	158	138-4304-407.....	150	141-0000-924.....	186
133-3404-006.....	16	133-5303-406.....	207	134-1012-021.....	158	138-4304-407.....	249	141-0000-925.....	186
133-3404-006.....	207	133-5304-401.....	26	134-1012-041.....	159	138-4307-407.....	150	141-0000-927.....	186
133-3404-101.....	17	133-5304-401.....	207	134-1018-001.....	159	138-4307-407.....	252	141-0303-412.....	99
133-3404-101.....	210	133-5304-406.....	26	134-1018-011.....	159	138-4308-407.....	150	141-0303-412.....	219
133-3404-106.....	17	133-5304-406.....	207	134-1018-021.....	159	138-4308-407.....	252	141-0304-412.....	99
133-3404-106.....	210	133-5402-001.....	26	134-1018-031.....	159	138-4316-407.....	150	141-0304-412.....	219
133-3407-101.....	17	133-5402-001.....	207	134-1019-151.....	160	138-4316-407.....	252	141-0307-412.....	99
133-3407-101.....	210	133-5402-006.....	26	134-1019-161.....	160	138-4318-407.....	150	141-0307-412.....	219
133-3407-106.....	17	133-5402-006.....	207	134-1019-171.....	160	138-4318-407.....	252	141-0308-412.....	99
133-3407-106.....	210	133-5402-101.....	26	134-1019-181.....	161	138-4349-407.....	150	141-0308-412.....	219
133-3433-001.....	16	133-5402-101.....	210	134-1019-361.....	180	138-4349-407.....	252	141-0403-012.....	99

Part Number Index

142-0761-871.....	228	142-1701-571.....	73	142-4403-101.....	80	142-5407-006.....	219	251-0111-003.....	273
142-0761-881.....	92	142-1701-576.....	73	142-4403-101.....	224	142-5407-006.....	220	251-0115-002.....	273
142-0761-881.....	228	142-1701-581.....	73	142-4403-106.....	80	142-5407-101.....	84	415-0001-006.....	169
142-0761-891.....	93	142-1701-586.....	73	142-4403-106.....	224	142-5407-101.....	224	415-0001-012.....	169
142-0761-891.....	228	142-1701-591.....	73	142-4404-001.....	80	142-5407-101.....	229	415-0001-018.....	169
142-0771-821.....	92	142-1701-596.....	73	142-4404-001.....	219	142-5407-106.....	84	415-0001-024.....	169
142-0771-821.....	228	142-1701-601.....	70	142-4404-006.....	80	142-5407-106.....	224	415-0001-030.....	169
142-0771-831.....	93	142-1701-606.....	72	142-4404-006.....	219	142-5407-106.....	229	415-0001-036.....	169
142-0771-831.....	228	142-1701-611.....	72	142-4404-101.....	80	142-5408-001.....	84	415-0002-006.....	169
142-0791-801.....	63	142-1701-616.....	72	142-4404-101.....	224	142-5408-001.....	219	415-0002-012.....	169
142-0791-801.....	227	142-1701-621.....	72	142-4404-106.....	80	142-5408-006.....	84	415-0002-018.....	169
142-0791-801.....	236	142-1701-626.....	72	142-4404-106.....	224	142-5408-006.....	219	415-0002-024.....	169
142-0791-811.....	63	142-1701-631.....	72	142-4407-001.....	80	142-5408-101.....	84	415-0002-030.....	169
142-0791-811.....	227	142-1701-636.....	72	142-4407-001.....	219	142-5408-101.....	224	415-0002-036.....	169
142-0791-811.....	236	142-1701-641.....	72	142-4407-001.....	220	142-5408-106.....	84	415-0003-006.....	168
142-0791-821.....	63	142-1701-646.....	72	142-4407-006.....	80	142-5408-106.....	224	415-0003-012.....	168
142-0791-821.....	227	142-1701-701.....	69	142-4407-006.....	219	142-5435-001.....	84	415-0003-018.....	168
142-0791-821.....	236	142-1701-706.....	69	142-4407-006.....	220	142-5435-001.....	220	415-0003-024.....	168
142-0801-201.....	56	142-1701-821.....	63	142-4407-101.....	80	142-5435-006.....	84	415-0003-030.....	168
142-0801-206.....	56	142-1701-821.....	227	142-4407-101.....	224	142-5435-006.....	220	415-0003-036.....	168
142-0801-301.....	56	142-1701-821.....	236	142-4407-101.....	229	142-5435-101.....	84	415-0004-006.....	169
142-0801-306.....	56	142-1701-831.....	63	142-4407-106.....	80	142-5435-101.....	229	415-0004-012.....	169
142-0801-421.....	55	142-1701-831.....	227	142-4407-106.....	224	142-5435-106.....	84	415-0004-018.....	169
142-0801-421.....	216	142-1701-831.....	236	142-4407-106.....	229	142-5435-106.....	229	415-0004-024.....	169
142-0801-801.....	59	142-1711-001.....	69	142-4408-001.....	80	142-5439-001.....	84	415-0004-030.....	169
142-0801-806.....	59	142-1711-006.....	69	142-4408-001.....	219	142-5439-001.....	220	415-0004-036.....	169
142-0801-811.....	59	142-1711-011.....	70	142-4408-006.....	80	142-5439-006.....	84	415-0005-006.....	169
142-0801-816.....	59	142-1711-016.....	70	142-4408-006.....	219	142-5439-006.....	220	415-0005-012.....	169
142-0801-821.....	59	142-1711-021.....	70	142-4408-101.....	80	142-5439-101.....	84	415-0005-018.....	169
142-0801-826.....	59	142-1711-026.....	70	142-4408-101.....	224	142-5439-101.....	229	415-0005-024.....	169
142-0801-831.....	59	142-1711-031.....	70	142-4408-106.....	80	142-5439-106.....	84	415-0005-030.....	169
142-0801-836.....	59	142-1711-036.....	70	142-4408-106.....	224	142-5439-106.....	229	415-0005-036.....	169
142-0901-401.....	76	142-1711-061.....	70	142-4435-001.....	80	142-5701-201.....	85	415-0006-006.....	169
142-0901-406.....	76	142-1711-066.....	70	142-4435-001.....	220	142-5701-206.....	85	415-0006-012.....	169
142-0901-801.....	76	142-1711-511.....	74	142-4435-006.....	80	142-5701-501.....	85	415-0006-018.....	169
142-0901-806.....	76	142-1711-516.....	74	142-4435-006.....	220	142-5701-506.....	85	415-0006-024.....	169
142-0901-811.....	76	142-1711-521.....	74	142-4435-101.....	80	142-5701-801.....	85	415-0006-030.....	169
142-0901-816.....	76	142-1711-526.....	74	142-4435-101.....	229	142-5701-806.....	85	415-0006-036.....	169
142-0901-821.....	76	142-1721-001.....	65	142-4435-106.....	80	142-5701-811.....	85	415-0007-006.....	169
142-0901-826.....	76	142-1721-006.....	65	142-4435-106.....	229	142-5701-816.....	85	415-0007-012.....	169
142-0901-861.....	77	142-1721-011.....	65	142-4439-001.....	80	142-9303-411.....	87	415-0007-018.....	169
142-0901-866.....	77	142-1721-016.....	65	142-4439-001.....	220	142-9303-411.....	219	415-0007-024.....	169
142-0901-921.....	77	142-1721-021.....	66	142-4439-006.....	80	142-9403-011.....	87	415-0007-030.....	169
142-0901-931.....	77	142-1721-026.....	66	142-4439-006.....	220	142-9403-011.....	219	415-0007-036.....	169
142-0901-941.....	77	142-1721-031.....	66	142-4439-101.....	80	142-9403-101.....	87	415-0008-006.....	169
142-1000-001.....	75	142-1721-036.....	66	142-4439-101.....	229	142-9403-101.....	224	415-0008-012.....	169
142-1000-002.....	75	142-1721-041.....	66	142-4439-106.....	80	142-9404-011.....	87	415-0008-018.....	169
142-1000-003.....	75	142-1721-046.....	66	142-4439-106.....	229	142-9404-011.....	219	415-0008-024.....	169
142-1000-004.....	75	142-1721-051.....	66	142-4701-201.....	81	142-9404-101.....	87	415-0008-030.....	169
142-1000-033.....	44	142-1721-056.....	66	142-4701-206.....	81	142-9404-101.....	224	415-0008-036.....	169
142-1403-001.....	49	142-1731-006.....	64	142-4701-501.....	81	142-9407-001.....	87	415-0009-006.....	170
142-1403-001.....	219	142-1731-011.....	64	142-4701-506.....	81	142-9407-001.....	219	415-0009-012.....	170
142-1403-006.....	219	142-1731-016.....	64	142-4701-801.....	81	142-9407-101.....	87	415-0009-018.....	170
142-1404-001.....	49	142-1731-021.....	64	142-4701-806.....	81	142-9407-101.....	224	415-0009-024.....	170
142-1404-001.....	219	142-1731-026.....	64	142-5303-401.....	84	142-9701-201.....	88	415-0009-030.....	170
142-1404-006.....	219	142-1731-031.....	64	142-5303-401.....	219	142-9701-211.....	88	415-0009-036.....	170
142-1407-001.....	49	142-1731-036.....	64	142-5303-406.....	84	142-9701-301.....	88	415-0010-006.....	169
142-1407-001.....	219	142-1801-551.....	74	142-5303-406.....	219	142-9701-801.....	89	415-0010-012.....	169
142-1407-006.....	219	142-1801-556.....	74	142-5304-401.....	84	142-9701-811.....	89	415-0010-018.....	169
142-1408-001.....	49	142-1801-561.....	74	142-5304-401.....	219	142-9801-201.....	88	415-0010-024.....	169
142-1408-001.....	219	142-1801-566.....	74	142-5304-406.....	84	144-0000-910.....	187	415-0010-030.....	169
142-1408-006.....	219	142-1801-571.....	74	142-5304-406.....	219	144-0000-910.....	273	415-0010-036.....	169
142-1701-011.....	68	142-1801-576.....	74	142-5307-401.....	84	145-0693-001.....	43	415-0011-006.....	170
142-1701-016.....	68	142-1801-601.....	74	142-5307-401.....	219	145-0693-001.....	212	415-0011-012.....	170
142-1701-031.....	67	142-1801-606.....	74	142-5307-406.....	84	145-0693-002.....	43	415-0011-018.....	170
142-1701-036.....	67	142-1801-611.....	74	142-5307-406.....	219	145-0693-002.....	212	415-0011-024.....	170
142-1701-041.....	68	142-1801-616.....	74	142-5308-401.....	84	145-0694-001.....	43	415-0011-030.....	170
142-1701-046.....	68	142-1801-621.....	74	142-5308-401.....	219	145-0694-001.....	212	415-0011-036.....	170
142-1701-121.....	68	142-1801-626.....	74	142-5308-406.....	84	145-0694-002.....	43	415-0011-036.....	170
142-1701-126.....	68	142-1901-821.....	49	142-5308-406.....	219	145-0694-002.....	212	415-0013-006.....	170
142-1701-131.....	67	142-4303-401.....	80	142-5403-001.....	84	145-0701-001.....	43	415-0013-012.....	170
142-1701-136.....	67	142-4303-401.....	219	142-5403-001.....	219	145-0701-002.....	43	415-0013-018.....	170
142-1701-191.....	69	142-4303-406.....	80	142-5403-006.....	84	145-0701-601.....	43	415-0013-024.....	170
142-1701-196.....	69	142-4303-406.....	219	142-5403-006.....	219	145-0701-602.....	43	415-0013-030.....	170
142-1701-201.....	68	142-4304-401.....	80	142-5403-101.....	84	145-0701-602.....	43	415-0013-036.....	170
142-1701-206.....	68	142-4304-401.....	219	142-5403-101.....	224	145-0701-611.....	43	415-0014-006.....	164
142-1701-501.....	72	142-4304-406.....	80	142-5403-106.....	84	145-0701-612.....	43	415-0014-012.....	164
142-1701-506.....	72	142-4304-406.....	219	142-5403-106.....	224	145-0901-801.....	44	415-0014-018.....	164
142-1701-511.....	72	142-4307-401.....	80	142-5404-001.....	84	145-0901-811.....	44	415-0014-024.....	164
142-1701-516.....	72	142-4307-401.....	219	142-5404-001.....	219	145-0901-821.....	44	415-0014-030.....	164
142-1701-521.....	72	142-4307-406.....	80	142-5404-006.....	84	146-0403-007.....	184	415-0014-036.....	164
142-1701-526.....	72	142-4307-406.....	219	142-5404-006.....	219	146-0403-007.....	256	415-0015-006.....	164
142-1701-531.....	73	142-4308-401.....	80	142-5404-101.....	84	146-0403-107.....	184	415-0015-012.....	164
142-1701-536.....	73	142-4308-401.....	219	142-5404-101.....	224	146-0403-107.....	255	415-0015-018.....	164
142-1701-541.....	73	142-4308-406.....	80	142-5404-106.....	84	146-0404-007.....	184	415-0015-024.....	164
142-1701-546.....	73	142-4308-406.....	219	142-5404-106.....	224	146-0404-007.....	256	415-0015-030.....	164
142-1701-551.....	73	142-4403-001.....	80	142-5407-001.....	84	146-0404-107.....	184	415-0015-036.....	164
142-1701-556.....	73	142-4403-001.....	219	142-5407-001.....	219	146-0404-107.....	255	415-0016-006.....	164
142-1701-561.....	73	142-4403-006.....	80	142-5407-001.....	220	146-0701-201.....	184	415-0016-012.....	164
142-1701-566.....	73	142-4403-006.....	219	142-5407-006.....	84	146-0701-301.....	184	415-0016-018.....	164
						1-8-0313-001.....	268	415-0016-024.....	164

Competitor Cross Reference

ADC EMERSON	2009-7511-000.....131-1701-206	9030-9023-003.....142-0303-416	221984-5.....CPFI-UG88-3	228214-1.....131-3403-116
BNC-1.....CPMC-68-35	2009-7511-000.....131-3701-206	9030-9023-006.....142-0307-416	221984-7.....CPFI-UG88-1	228214-2.....131-1402-116
BNC-2.....CPMC-68-2	2010-1511-000.....131-1701-371	9030-9023-019.....142-0304-416	221988-1.....CP-AD506	228214-2.....131-3402-116
BNC-3.....CPMC-68-33	2010-1511-000.....131-3701-301	9043-1523-002.....142-0402-101	222165-2.....CP-AD503	228215-1.....131-3701-406
BNC-4.....CPMC-68-3	2010-7511-000.....131-1701-376	9043-1523-003.....142-0403-101	222319-1.....CP-AD512	228216-1.....131-3701-416
BNC-6.....CPMC-68-10	2010-7511-000.....131-3701-306	9045-1523-006.....142-0407-101	222321-1.....CP-AD809	228226-1.....CP-AD556
BNC-6.....CPMC-68-50	2018-1511-001.....131-3701-801	9044-9513-000.....142-1701-606	222428-1.....CPFI-UG89-2	228509-9.....CP-625U
BNC-7.....CPMC-68-18	2018-7511-001.....131-3701-806	9044-9513-001.....142-1701-616	222506-2.....CPMC-TNC-2	3-227079-0.....CPMC-88-5
BNC-8.....CPMC-68-45	2019-1511-000.....131-3701-411	9045-9513-000.....142-1701-506	222506-4.....CPMC-TNC-13	3-227079-1.....CPMC-88-5
BNC-10.....CPMC-68-36	2019-7511-000.....131-3701-416	9045-9513-001.....142-1701-516	225395-1.....CPMC-88-1	3-227079-2.....CPMC-88-5
BNC-13.....CPMC-68-34	2025-1511-000.....131-3801-201	9046-9513-000.....142-1801-606	225395-2.....CPMC-88-2	3-227079-7.....CPMC-88-14
	2025-7511-000.....131-3801-216	9046-9513-001.....142-1801-616	225395-5.....CPMC-88-1	3-227086-6.....CPN-1
AEP EMERSON	2042-1511-000.....131-1801-371	9048-9513-000.....142-1701-626	225395-6.....CPMC-88-13	329517.....CP-AD503
204.....131-3701-401	2042-1511-000.....131-3801-301	9049-9513-000.....142-1701-526	225395-7.....CPM-88-19	329518.....CP-AD505
209.....131-1701-201	2042-7511-000.....131-1801-376	9050-9513-000.....142-1801-626	225395-8.....CPM-88-20	330024.....CP-AD556
209.....131-3701-201	2042-7511-000.....131-3801-316	9074-9513-000.....142-1701-576	225395-9.....CPMC-88-14	331350.....CPMC-88-2
210.....131-1701-371	2105-1521-002.....131-1402-101	9076-1113-000.....142-1701-011	225532-1.....142-0407-016	4-227079-1.....CPMC-88-1
210.....131-3701-301	2105-1521-002.....131-3402-101	9076-1113-000.....142-1701-016	225532-9.....142-0407-016	4-227079-3.....CPMC-88-1
219.....131-3701-411	2105-1521-003.....131-1403-101	9079-9513-000.....142-1701-556	225542-1.....142-0307-016	4-227079-9.....CPMC-88-10
222.....131-3901-401	2105-1521-003.....131-3403-101	9079-9513-001.....142-1701-566	225608-9.....142-0307-416	4-331350-0.....CPMC-88-3
225.....131-3801-201	2105-7521-002.....131-1402-116	9101-1573-003.....142-0403-001	225609-1.....142-0407-101	413592-2.....CP-AD505
242.....131-1801-371	2105-7521-002.....131-3402-116	9130-1573-002.....142-0302-401	225609-4.....142-0403-101	413592-9.....CP-AD505
242.....131-3801-301	2105-7521-003.....131-1403-116	9130-1573-003.....142-0303-401	225661-2.....CPN-1	413771-3.....CP-89-19-BM1
1-104.....131-6701-401	2105-7521-003.....131-3403-116	9130-1573-006.....142-0307-401	225886-4.....CPMC-88-26	414160-7.....CPN-68-13
1-109.....131-6701-201	2110-1511-000.....131-3701-341	9201-1553-002.....142-0202-011	226279-1.....CPL-259-1	414160-9.....CPN-68-1
1-110.....131-6701-301	2110-7511-000.....131-3701-346	9201-1553-003.....142-0203-011	226279-2.....CPL-259-8	414168-3.....CP-TNC-89-19-BM
1-119.....131-6701-411	218/063.....131-3701-801	9201-1553-006.....142-0207-011	226279-3.....CPL-259-2	414265-1.....CPFI-UG88-1
1-302/188.....131-6403-001	2484-1511-000.....131-3701-631	9230-1553-002.....142-0102-401	226600-1.....MINI-UHF-1	414265-3.....CPFI-UG89-2
1-303/188.....131-6303-401	2484-7511-000.....131-3701-636	9230-1553-003.....142-0103-401	227000-5.....CPMC-TNC-1	414265-4.....CPFI-UG88-10
1-305/188.....131-6403-101	401/188.....131-3303-001	9243-1553-002.....142-0202-101	227000-7.....CPMC-TNC-2	414265-5.....CPFI-UG88-3
1002-1571-003.....131-6403-001	401/196.....131-3302-001	9243-1553-003.....142-0203-101	227079-1.....CPMC-88-1	414311-1.....CP-AD506
1002-7571-003.....131-6403-006	402/188.....131-1403-001	9243-1553-006.....142-0207-101	227079-2.....CPMC-88-13	414414-1.....CP-AD555
1003-1571-003.....131-6303-401	402/188.....131-3403-001	9301-1063-109.....142-0694-021	227079-3.....CPMC-88-2	414459-1.....CP-BNC-PC-016
1003-7571-003.....131-6303-406	402/196.....131-3402-001	9304-1113-013.....142-1701-191	227079-5.....CPMC-88-1	414580-2.....CPFI-UG88-1
1004-1511-000.....131-6701-401	405/188.....131-1403-101	9304-9113-013.....142-1701-196	227079-7.....CPMC-88-2	414580-3.....CPFI-UG89-2
1004-7511-000.....131-6701-406	405/188.....131-3403-101	9308-1113-001.....142-1701-201	227079-9.....CPMC-88-1	414580-5.....CPFI-UG88-10
1009-1511-000.....131-6701-201	405/196.....131-1402-101	9308-9113-001.....142-1701-206	227632-1.....131-6701-406	414586-1.....CPMC-88-1
1009-7511-000.....131-6701-206	405/196.....131-3402-101	9401-1083-010.....142-0693-001	227633-1.....131-6701-416	414586-5.....CPMC-88-1
1010-1511-000.....131-6701-301	5222-1501-000.....131-3901-401	9401-1083-109.....142-0694-001	227677-1.....CP-BNC-PC-009	414666-1.....CP-AD503
1019-1511-000.....131-6701-411	5222-7501-000.....131-3901-406	9402-1083-009.....142-0594-001	227726-3.....CP-AD520	51751-1.....131-6303-401
1019-7511-000.....131-6701-416	5909-1103-000.....142-0901-401	9402-1083-010.....142-0593-001	227754-1.....CP-1094-U	51751-3.....131-6303-401
1105-1521-003.....131-6403-101	5917-1103-000.....142-0901-801	9404-1113-000.....142-0701-631	227754-2.....CP-1094-U	51753-1.....131-6403-101
1105-7521-003.....131-6403-106	5918-1103-000.....142-0901-811	9408-1113-000.....142-0701-621	227754-3.....CP-1094-U	51753-4.....131-6403-101
1110-1511-000.....131-6701-341	9001-1023-001.....142-0408-011	9412-1113-000.....142-0701-401	227945-2.....CP-AD850	5-227079-8.....CPMC-88-3
1110-7511-000.....131-6701-346	9001-1023-003.....142-0403-011	9413-1113-000.....142-0701-411	227945-5.....CP-AD850	5-331350-3.....CPMC-88-2
2001-1571-002.....131-3302-001	9001-1023-006.....142-0407-011	9424-1513-000.....142-0701-701	227839-1.....CP-TNC-PC-002	5801-7985-63.....133-3693-001
2001-1571-003.....131-3303-001	9001-1023-019.....142-0404-011	9424-9513-000.....142-0701-706	228226-3.....CP-AD556	5818-5002-10.....142-0003-236
2001-7571-002.....131-3302-006	9001-9023-001.....142-0408-016	9453-1083-009.....142-0594-401	227984-1.....CPFI-UG88-2	5818-5003-10.....142-0003-246
2001-7571-003.....131-3303-006	9001-9023-003.....142-0403-016	9453-1083-010.....142-0593-401	228026-2.....131-6402-006	5818-5005-10.....142-0002-226
2002-1541-010.....131-3693-001	9001-9023-006.....142-0407-016	9504-9113-009.....142-1701-546	228026-3.....131-6403-006	5831-5002-10.....133-3402-006
2002-1571-002.....131-3402-001	9001-9023-019.....142-0404-016	9504-9113-031.....142-1701-536	228028-1.....131-6303-406	5831-5003-10.....133-3403-006
2002-1571-003.....131-1403-001	9002-1023-003.....142-0303-011	9508-9113-001.....142-1701-646	228028-3.....131-6303-406	5837-5002-10.....133-3402-106
2002-1571-003.....131-3403-001	9002-1023-006.....142-0307-011	9508-9113-002.....142-1701-636	228030-1.....131-6403-106	5837-5003-10.....133-3403-106
2002-7541-010.....131-3693-016	9002-1023-019.....142-0304-011	9576-9113-001.....142-1701-586	228030-2.....131-6402-106	5837-5010-63.....133-3403-101
2003-1541-010.....131-3593-401	9002-9023-001.....142-0308-016	9576-9113-003.....142-1701-596	228030-3.....131-6403-106	5862-5002-10.....133-3701-216
2003-7541-010.....131-3593-406	9002-9023-003.....142-0303-016	9609-1513-000.....142-0701-531	228212-1.....131-1701-206	5862-5003-10.....133-3701-206
2004-1511-000.....131-3701-401	9002-9023-006.....142-0307-016	9609-9513-000.....142-0701-536	228212-1.....131-3701-206	5862-5004-10.....133-3701-226
2004-7511-000.....131-3701-406	9002-9023-019.....142-0304-016	9649-1113-000.....142-0801-201	228213-1.....131-1403-016	5863-0000-10.....133-3801-201
2005-1541-010.....131-1693-101	9030-0123-001.....142-0308-411	9650-1113-000.....142-0701-201	228213-1.....131-3403-016	5864-5001-10.....133-3701-306
2005-1541-010.....131-3693-101	9030-1023-003.....142-0303-411		228213-2.....131-3402-016	5864-5002-10.....133-3701-326
2005-7541-010.....131-3693-116	9030-1023-006.....142-0307-411	AMP SEE TYCO/AMP	228213-3.....131-1403-016	5864-5003-10.....133-3701-316
2009-1511-000.....131-1701-201	9030-1023-019.....142-0304-411	AMP EMERSON	228213-3.....131-3403-016	6-227079-0.....CPMC-88-13
2009-1511-000.....131-3701-201	9030-9023-001.....142-0308-416	221984-1.....CPFI-UG88-2	228214-1.....131-1403-116	6-227079-1.....CPMC-88-13

Competitor Cross Reference

BNC-PS3C-174CPM-88-19
 BNC-PS3C-P5962 CPMC-88-10
 BNC-PS3C-PL58 CPMC-88-11
 BNC-T-JPJ CP-AD505
 TNC-A5-JJ CP-AD355
 TNC-PS3C-58CPMC-TNC-1
 TNC-PS3C-5962CPMC-TNC-2

ANRITSU.....EMERSON

K100B142-1000-033
 K101M-85145-0693-002
 K102F145-0701-002
 K103F145-0701-602
 K104F145-0701-612

AUTOMATIC.....EMERSON

3301-640-919142-0403-001
 3301-940-801142-0202-011
 3301-940-819142-0203-011
 3301-940-888142-0207-011
 3302-640-901142-0402-101
 3302-640-980142-0407-101
 3302-940-801142-0202-101
 3302-940-819142-0203-101
 3302-940-888142-0207-101
 3307-640-901142-0302-401
 3307-640-919142-0303-401
 3307-940-801142-0102-401
 3307-940-819142-0103-401
 E-3301-042-104142-0694-001
 E-3301-044-104142-0694-031
 E-3301-044-124142-0693-001
 E-3302-045-919142-0403-101
 E-3306-942-104142-0594-001
 E-3306-942-124142-0593-001
 E-3307-962-104142-0594-401
 E-3307-962-124142-0593-401
 E-3337-945-000142-0701-401
 E-3341-000-000142-0701-631
 E-3341-960-100142-0701-621
 E-3352-960-000142-0901-811
 E-3353-000-000142-0901-821
 E-3356-000-000142-0901-801
 E-3357-040-000142-0901-401
 H-4601-004-919131-6403-001
 H-4602-045-919131-6403-101
 H-4607-004-919131-6303-401
 H-4632-000-000131-6701-411
 H-4637-000-000131-6701-401
 H-4695-000-000131-6701-201
 H-4697-000-000131-6701-301
 H-6491-000-703131-3701-631
 H-6901-004-919131-1403-001
 H-6901-004-919131-3403-001
 H-6901-045-125131-3693-001
 H-6902-040-125131-1693-101
 H-6902-040-125131-3693-101
 H-6902-045-901131-1402-101
 H-6902-045-919131-1403-101
 H-6902-045-919131-3403-101
 H-6906-004-901131-3302-001
 H-6906-004-919131-3303-001
 H-6907-045-125131-3593-401

H-6932-000-000131-3701-411
 H-6937-000-000131-3701-401
 H-6957-000-000131-3901-401
 H-6991-000-000131-3801-201
 H-6993-000-000131-1801-371
 H-6995-000-000131-1701-201
 H-6995-000-000131-3701-201
 H-6997-000-000131-1701-371
 H-6997-000-000131-3701-301
 SI333-2704-308142-0701-411

BERG.....EMERSON

32AS100-1131-3901-401
 32J102-1131-3303-001
 32JR104-1131-3701-401
 32JR107-1131-3701-201
 32JR110-1131-3701-411
 32JR111-1131-3701-301
 32JR122-1131-3701-341
 32JR189-1131-3711-201
 32P100-1131-1403-001
 32P100-6131-3402-001
 32P111-1131-1403-101
 32P111-13131-1402-101
 32PR103-1131-3801-201
 32PR104-1131-3801-301
 37JR101-1131-6701-411
 37JR104-2131-6701-201
 37JR108-1131-6701-401
 37JR110-1131-6701-301
 37JS102-1131-6303-401
 37P104-1131-6403-101
 37P106-1131-6403-001
 37T100-1142-0003-301
 39JR128-5142-0701-301
 39JR359-1142-0701-201
 39JR363-1142-0701-876
 39JR364-1142-0701-506
 39JR364-2142-0701-501
 69JR100-2135-3701-201
 69JR101-2135-3701-301
 69JR103-2135-3711-801
 69P101-2135-3801-201
 69P103-4135-3404-001
 69P103-6135-3403-001
 69P104-3135-3403-101
 69P104-4135-3404-101
 69P104-6135-3402-101

BIRNBACH.....EMERSON

400108-0750-001
 401108-0753-001
 406108-0745-101
 414108-0750-002
 1160108-030X-001
 1164108-030X-001
 1169108-030X-001
 400A108-0750-001

CABLEWAVE.....EMERSON

700012131-6701-401
 700013131-6701-401
 700015131-6701-411

700053131-6701-201
 700056131-6701-301
 700166131-3701-411
 700169131-3701-401
 700178131-3593-401
 700188131-3901-401
 700209131-1701-201
 700209131-3701-201
 700213131-3801-201
 700214131-1701-371
 700214131-3701-301
 700218131-1801-371
 700218131-3801-301
 700306131-6403-001
 700311131-6303-401
 700326131-6403-101
 700400131-3303-001
 700401131-3302-001
 700405131-1403-001
 700405131-3403-001
 700406131-3402-001
 700425131-1403-101
 700425131-3403-101
 700426131-1402-101
 700426131-3402-101
 700466131-3693-001
 700473131-1693-101
 700473131-3693-101

CDI/TENSOLITE.....EMERSON

201-1CC145-0694-001
 201-1CCSF145-0694-002
 201-2CC145-0693-001
 201-2CCSF145-0693-002
 204CC145-0701-001
 223CC145-0901-811
 224CC145-0901-801
 225CC145-0901-821
 230CC145-0701-611
 230CCSF145-0701-612
 231CC145-0701-601
 231CCSF145-0701-602
 240CCSF145-0701-002
 5602-2CC142-1701-631
 5602-2CC-SF142-1701-636
 5602-4CC142-1701-601
 5602-4CC-SF142-1701-606
 5602-5CC142-1701-611
 5602-5CC-SF142-1701-616
 5602-6CC142-1701-621
 5602-6CC-SF142-1701-626
 5603-2CC142-1701-581
 5603-2CC-SF142-1701-586
 5603-4CC142-1701-551
 5603-4CC-SF142-1701-556
 5603-5CC142-1701-561
 5603-5CC-SF142-1701-566
 5603-6CC142-1701-571
 5603-6CC-SF142-1701-576
 5604-2CC142-1701-531
 5604-2CC-SF142-1701-536
 5604-4CC142-1701-501
 5604-4CC-SF142-1701-506

5604-5CC142-1701-511
 5604-5CC-SF142-1701-516
 5604-6CC142-1701-521
 5604-6CC-SF142-1701-526
 5606-2CC142-1801-631
 5606-2CC-SF142-1801-636
 5606-4CC142-1801-601
 5606-4CC-SF142-1801-606
 5606-5CC142-1801-611
 5606-5CC-SF142-1801-616
 5606-6CC142-1801-621
 5606-6CC-SF142-1801-626
 5607-4CC142-1801-551
 5607-4CC-SF142-1801-556
 5607-5CC142-1801-561
 5607-5CC-SF142-1801-566
 5607-6CC142-1801-571
 5607-6CC-SF142-1801-576
 5608-2CC142-1801-531
 5608-2CC-SF142-1801-536
 5663-2CC142-1701-631
 5663-2CC-SF142-1701-636
 5663-4CC142-1701-601
 5663-4CC-SF142-1701-606
 5663-5CC142-1701-611
 5663-5CC-SF142-1701-616
 5663-6CC142-1701-621
 5663-6CC-SF142-1701-626
 5664-2CC142-1801-631
 5664-2CC-SF142-1801-636
 5664-4CC142-1801-601
 5664-4CC-SF142-1801-606
 5664-5CC142-1801-611
 5664-5CC-SF142-1801-616
 5664-6CC142-1801-621
 5664-6CC-SF142-1801-626
 5665-2CC142-1701-531
 5665-2CC-SF142-1701-536
 5665-4CC142-1701-501
 5665-4CC-SF142-1701-506
 5665-5CC142-1701-511
 5665-5CC-SF142-1701-516
 5665-6CC142-1701-521
 5665-6CC-SF142-1701-526
 5666-2CC142-1801-531
 5666-2CC-SF142-1801-536
 5850-1CC142-0693-101
 5850-2CC142-0694-101
 5937-2CC142-1701-581
 5937-2CC-SF142-1701-586
 5937-4CC142-1701-551
 5937-4CC-SF142-1701-556
 5937-5CC142-1701-561
 5937-5CC-SF142-1701-566
 5937-6CC142-1701-571
 5937-6CC-SF142-1701-576
 5938-4CC142-1801-551
 5938-4CC-SF142-1801-556
 5938-5CC142-1801-561
 5938-5CC-SF142-1801-566
 5938-6CC142-1801-571
 5938-6CC-SF142-1801-576
 5941-2CC142-1701-581

5941-2CC-SF142-1701-586
 5941-4CC142-1701-551
 5941-4CC-SF142-1701-556
 5941-5CC142-1701-561
 5941-5CC-SF142-1701-566
 5941-6CC142-1701-571
 5941-6CC-SF142-1701-576
 5942-4CC142-1801-551
 5942-4CC-SF142-1801-556
 5942-5CC142-1801-561
 5942-5CC-SF142-1801-566
 5942-6CC142-1801-571
 5942-6CC-SF142-1801-576
 5980-1CC142-1701-541
 5980-1CC-SF142-1701-546
 5980-2CC142-1701-531
 5980-2CC-SF142-1701-536
 5980-4CC142-1701-501
 5980-4CC-SF142-1701-506
 5980-5CC142-1701-511
 5980-5CC-SF142-1701-516
 5980-6CC142-1701-521
 5980-6CC-SF142-1701-526
 5981-1CC142-1701-641
 5981-1CC-SF142-1701-646
 5981-2CC142-1701-631
 5981-2CC-SF142-1701-636
 5981-4CC142-1701-601
 5981-4CC-SF142-1701-606
 5981-5CC142-1701-611
 5981-5CC-SF142-1701-616
 5981-6CC142-1701-621
 5981-6CC-SF142-1701-626
 5982-1CC142-1801-541
 5982-1CC-SF142-1801-546
 5982-2CC142-1801-531
 5982-2CC-SF142-1801-536
 5983-1CC142-1801-641
 5983-1CC-SF142-1801-646
 5983-2CC142-1801-631
 5983-2CC-SF142-1801-636
 5983-4CC142-1801-601
 5983-4CC-SF142-1801-606
 5983-5CC142-1801-611
 5983-5CC-SF142-1801-616
 5983-6CC142-1801-621
 5983-6CC-SF142-1801-626

COAXIM.....EMERSON

3130-12-1142-1701-601
 3130-12-9142-1701-606
 3130-15-1142-1701-611
 3130-15-9142-1701-616
 3130-18-1142-1701-621
 3130-18-9142-1701-626
 3130-20-1142-1701-631
 3130-20-9142-1701-636
 3130-36-1142-1701-641
 3130-36-9142-1701-646
 12/1/31142-1701-501
 12/9/31142-1701-506
 3131-15-1142-1701-511
 3131-15-9142-1701-516

Competitor Cross Reference

11SMA-50-3-42.....142-0694-031	85 MCX-50-0-1.....133-3701-301	6064.....105-2204-105	2025-6-9-MO6.....CPMC-78-2	KC-59-300.....CPMC-88-3
11SMA-50-3-64.....142-0694-011	85MMCX-50-0-1.....135-3701-301	6066.....105-2201-101	2025-7-9.....CPMC-78-3	KC-59-303.....CPMC-88-13
11SMA-50-3-65.....142-0694-001	85SMA-50-0-44.....142-0701-301	6067.....105-2202-101	2029-16-5.....CP-AD705	KC-59-306.....CPMC-88-18
11SMB-50-2-13.....131-3693-001	85SMB-50-0-1.....131-1701-371	6068.....105-2203-101	2029-16-9.....CP-AD705	KC-59-307.....CPMC-88-18
11SMB-50-1-10.....131-3402-001	85SMC-50-0-1/111.....131-6701-301	6069.....105-2207-101	2029-17-9.....CP-AD557	KC-59-346.....CPMC-88-13
11SMC-50-2-10/111.....131-6403-001	86SMC-50-2-2.....142-0003-301	6070.....105-2204-101	2029-3-5.....CP-AD705	KC-59-347.....CPMC-88-1
16MCX-50-1-5.....133-3402-101		6072.....108-0753-001	2065-1-9.....CPMC-68-2	KC-59-348.....CPMC-88-1
16MCX-50-2-5/111.....133-3403-101	KEYSTONE.....EMERSON	6076.....108-1002-001	2065-2-9.....CPMC-68-35	KC-59-362.....CPMC-88-19
16MCX-50-2-5/133.....133-3403-106	6000.....105-0301-001	6077.....108-1003-001	2065-3-9.....CPMC-68-50	KC-59-397.....CPMC-88-2
16MCX-50-2-3.....133-3693-101	6001.....105-0302-001	6078.....108-0302-001	2065-5-9.....CPMC-68-20	KC-59-399.....CPMC-88-13
16MMCX-50-1-1.....135-3402-101	6002.....105-0303-001	6079.....108-0303-001	2065-6-9.....CPMC-68-3	KC-59-400.....CPMC-88-1
16MMCX-50-1-2.....135-3436-101	6003.....105-0304-001	6080.....108-1762-101	2065-7-9.....CPMC-68-2	KC-59-414.....CPMC-88-1
16MMCX-50-2-1.....135-3693-101	6005.....105-0310-001	6081.....108-1763-101	2065-10-9.....CPMC-68-36	KC-59-414-MO6.....CPMC-88-1
16MMCX-50-2-4.....135-3403-101	6006.....105-0771-001	6082.....108-1762-101	2065-10-9.....CPMC-68-45	KC-59-415.....CPMC-88-12
16MMCX-50-2-6.....135-3404-101	6007.....105-0772-001	6083.....108-1763-101	2065-11-9.....CPMC-68-34	KC-59-416.....CPMC-88-14
16SMA-50-2-45.....142-0403-101	6008.....105-0773-001	6084.....108-1702-101	759-1.....CP-AD555	KC-59-416-MO6.....CPMC-88-14
16SMA-50-2-3.....142-0693-101	6012.....105-0201-200	6085.....108-1703-101	759-3.....CP-AD505	KC-59-417.....CPMC-88-13
16SMA-50-2-3.....142-0694-101	6013.....105-0202-200	6088.....108-0252-001	759-4.....CP-AD503	KC-59-417-MO6.....CPMC-88-13
16SMB-50-1-20.....131-1402-101	6014.....105-0203-200	6089.....108-0253-001	759-5.....CP-AD511	KC-59-421.....CPMC-88-1
16SMB-50-2-20.....131-1403-101	6015.....105-0204-200	6091.....108-0902-001	879-11-15-MA9.....CP-AD507	KC-59-422.....CPMC-88-13
16SMC-50-2-20.....131-6403-101	6017.....105-0210-200	6092.....108-0903-001	879-5-15-MA9.....CP-AD508	KC-59-423.....CPMC-88-1
21MCX-50-1-10.....133-3302-001	6018.....105-0801-001	6093.....108-0745-001	KA-59-103.....CPMC-TNC-1	KC-59-465.....CPMC-88-2
21MCX-50-2-10.....133-3303-001	6019.....105-0802-001	6094.....108-0745-002	KA-59-225.....CPMC-TNC-1	KC-59-482.....CPMC-88-2
21MMCX-50-1-1.....135-3302-001	6020.....105-0803-001	6095.....108-0740-102	KA-59-230.....CPMC-TNC-13	KC-59-61.....CPMC-88-1
21MMCX-50-1-2.....135-3303-001	6021.....105-0804-001	7004.....111-0102-001	KA-59-231.....CPMC-TNC-1	KC-59-616-MO6.....CPMC-88-3
22MCX-50-0-2.....133-3701-401	6022.....105-0807-001	7005.....111-0103-001	KA-59-232.....CPMC-TNC-2	KC-59-632-MO6.....CPMC-88-1
22SMA-50-0-44.....142-0701-401	6023.....105-0810-001	7006.....111-0702-001	KA-59-263.....CPMC-TNC-2	KC-59-655-MO6.....CPMC-88-14
22SMB-50-0-11.....131-3701-421	6024.....105-0251-001	7007.....111-0703-001	KA-59-265.....CPMC-TNC-1	KC-59-78.....CPMC-88-1
22SMB-50-0-2.....131-3701-411	6025.....105-0252-001	552-4.....108-0754-001	KA-59-287.....CPMC-TNC-1	KC-59-79.....CPMC-88-1
22SMB-50-0-3.....131-3701-401	6026.....105-0253-001	6074-1.....108-0750-001	KA-59-292.....CPMC-TNC-13	KC-59-80.....CPMC-88-13
22SMC-50-0-2.....131-6701-411	6030.....105-0601-001	6074-2.....108-0750-002	KA-59-385-MO6.....CPMC-TNC-2	KC-59-95.....CPMC-88-19
22SMC-50-0-3.....131-6701-401	6031.....105-0602-001	872-1.....142-0594-401	KA-59-406-MO6.....CPMC-TNC-1	KC-59-98.....CPMC-88-1
23SMA-50-0-41.....142-0701-621	6032.....105-0603-001	872-11.....142-0302-401	KA-59-44.....CPMC-TNC-1	KC-79-106.....CP-1094-U
23SMA-50-0-44.....142-0701-631	6033.....105-0604-001	872-12.....142-0303-401	KA-59-45.....CPMC-TNC-13	KC-79-106.....CP-1094-U
23SMA-50-0-120.....142-1701-201	6034.....105-0607-001	872-8.....142-0593-401	KA-59-46.....CPMC-TNC-2	KC-79-109.....CP-AD519
23SMA-50-0-122.....142-1701-191	6035.....105-0610-001	873-4.....142-0594-001	KA-59-57.....CPMC-TNC-13	KC-79-121.....CP-1094-U
23SMA-50-0-170.....142-1701-206	6036.....105-0851-001	873-9.....142-0593-001	KA-59-69.....CPMC-TNC-19	KC-79-123.....CP-AD519
23SMA-50-0-172.....142-1701-196	6037.....105-0852-001	874-1.....142-0701-401	KA-59-86.....CPMC-TNC-13	KC-79-131.....CP-1094-U
24MCX-50-1-10.....133-3302-401	6038.....105-0853-001	874-5.....142-0701-411	KA-59-94.....CPMC-TNC-2	KC-79-132.....CP-AD519
24MCX-50-1-10.....133-3303-401	6039.....105-0857-001	875-10-M09.....142-0693-001	KA-91-01.....CP-AD355	KC-79-35.....CP-1094-U
24SMA-50-2-41.....142-0593-401	6040.....105-0854-001	875-13.....142-0403-001	KA-91-05.....CP-AD306	KC-79-46.....CP-1094-U
24SMA-50-3-41.....142-0594-401	6041.....105-0860-001	875-4-M09.....142-0694-031	KA-91-09.....CP-AD355	KC-99-20.....CP-AD506
24SMC-50-2-10C/111.....131-6303-401	6042.....105-2201-201	875-8-M09.....142-0694-001	KA-91-18.....CP-AD300	KC-99-30.....CP-AD555
27SMA-50-0-1.....142-0701-531	6043.....105-2202-201	876-1.....142-0407-101	KA-99-114-MO6.....CP-AD356	KC-99-31.....CP-AD505
27SMA-50-0-51.....142-0701-536	6044.....105-2203-201	876-6.....142-0403-101	KA-99-59.....CP-AD300	KC-99-32.....CP-AD511
28SMA-50-0-1.....142-0701-701	6045.....105-2207-201	877-1.....142-0701-631	KA-99-62.....CP-AD355	KC-99-33.....CP-AD556
28SMA-50-0-51.....142-0701-706	6046.....105-2204-201	877-2.....142-0701-621	KC-59-104.....CPMC-88-13	KC-99-34.....CP-AD500
31MCX-50-0-1.....133-3901-801	6048.....105-1101-001	877-21.....142-0701-301	KC-59-107.....CPMC-88-12	KC-99-35.....CP-AD503
34SMB-50-0-2.....131-3901-401	6049.....105-1102-001	879-13.....142-0901-401	KC-59-115.....CPMC-88-13	KC-99-37.....CP-AD506
81MCX-50-0-1.....133-3801-201	6050.....105-1103-001	879-2-M09.....142-0901-811	KC-59-116.....CPMC-88-13	KC-99-40.....CP-AD521
81MMCX-50-0-1.....135-3801-201	6051.....105-1107-001	879-3.....142-0901-801	KC-59-123.....CPMC-88-1	KC-99-42.....CP-AD500
81SMB-50-0-1/111.....131-3801-201	6052.....105-1104-001		KC-59-128.....CPMC-88-2	KC-99-44.....CP-AD555
82MCX-50-0-1/111.....133-3701-201	6053.....105-1110-001	KINGS.....EMERSON	KC-59-152.....CPMC-88-19	KC-99-52.....CP-AD505
82MCX-50-0-1/133.....133-3701-206	6054.....105-0751-001	1209-1-15-MA9.....CP-AD810	KC-59-162.....CPMC-88-13	KC-99-54.....CP-AD521
82MCX-50-0-10.....133-3701-231	6055.....105-0752-001	1209-10.....CP-AD803	KC-59-167.....CPMC-88-13	KC-99-56.....CP-AD511
82MCX-50-0-2.....133-3701-201	6056.....105-0753-001	1209-13.....CP-AD850	KC-59-180.....CPMC-88-3	KC-99-64.....CP-AD505
82MMCX-50-0-1.....135-3701-201	6057.....105-0757-001	1209-18.....CP-AD807	KC-59-181.....CPMC-88-3	KC-99-95-MO6.....CP-AD556
82SMA-50-0-41.....142-0701-201	6058.....105-0754-001	1209-7.....CP-AD809	KC-59-223.....CPMC-88-18	KN-59-132.....CPN-8
82SMB-50-0-1/111.....131-1701-201	6059.....105-0760-001	2025-36-9.....CPMC-78-2	KC-59-279.....CPMC-88-13	KN-59-204-MO6.....CPN-1
82SMC-50-0-1.....131-6701-201	6060.....105-2201-105	2025-37-9.....CPMC-78-3	KC-59-290.....CPMC-88-1	KN-59-207.....CP-AD802
83MCX-0-2-5.....142-0003-231	6061.....105-2202-105	2025-44-9.....CPMC-68-33	KC-59-291.....CPMC-88-1	KN-59-273-MO6.....CPN-2
83SMC-0-2-2.....142-0003-201	6062.....105-2203-105	2025-51-9.....CPMC-78-2	KC-59-293.....CPMC-88-1	KN-99-35.....CP-AD809
84SMB-50-0-1.....131-1801-371	6063.....105-2207-105	2025-59-9.....CPMC-78-2	KC-59-294.....CPMC-88-2	KN-99-36.....CP-AD809

Competitor Cross Reference

352-900-0631H142-0404-101	29 K 203-400 D3133-3701-301	50-672-0000-31142-0901-801	39JR295-3142-1701-526	2950-6781142-1701-641
352-900-0631N142-0404-106	29 K 501-101 A3133-3302-406	50-673-0000-31142-0901-811	39JR295-4142-1701-536	2950-6784142-1701-621
352-900-1160H142-0407-101	29 K 501-101 D3133-3302-401	50-674-0000-31142-0901-821	39JR295-5142-1701-546	2950-6784142-1701-631
352-900-1160N142-0407-106	29 K 501-102 A3133-3303-406	50-675-0000-31142-0901-401	39JR296-1142-1701-606	2950-6786142-1701-601
352-900-1161H142-0408-101	29 K 501-102 D3133-3303-401	51-024-0000131-1403-001	39JR296-2142-1701-616	2950-6789142-1701-521
352-900-1161N142-0408-106	29 K 501-103 A3133-3304-406	51-024-0000131-3403-001	39JR296-3142-1701-626	2950-6789142-1701-531
353-060-0040H142-0701-301	29 K 501-103 D3133-3304-401	51-024-3196131-3402-001	39JR296-4142-1701-636	2951-6106142-1701-551
353-060-0040N142-0701-306	29 K 501-500 A3133-3701-406	51-025-0000131-3303-001	39JR296-5142-1701-646	2951-6107142-1701-571
450-060-0046H133-3801-201	29 K 501-500 D3133-3701-401	51-025-3196131-3302-001	39PR130-4142-1801-536	2951-6107142-1701-581
450-060-0046N133-3801-206	29 S 101-101 A3133-3402-006	51-043-0000131-3701-401	39PR130-5142-1801-546	2951-6110142-1701-611
450-500-0850H133-3693-001	29 S 101-101 D3133-3402-001	51-045-0000131-3701-411	39PR131-1142-1801-606	2951-6112142-1701-561
450-500-0850N133-3693-006	29 S 101-102 A3133-3403-006	51-045-4504131-3701-631	39PR131-2142-1801-616	2951-6114142-1701-551
450-900-0360H133-3402-001	29 S 101-102 D3133-3403-001	51-045-4524131-3701-621	39PR131-3142-1801-626	2951-6115142-1701-571
450-900-0360N133-3402-006	29 S 101-103 A3133-3404-006	51-049-0000131-3701-421	39PR131-4142-1801-636	2951-6115142-1701-581
450-900-0630H133-3403-001	29 S 101-103 D3133-3404-001	51-051-0000131-1701-201	39PR131-5142-1801-646	2951-6116142-1701-591
450-900-0630N133-3403-006	29 S 101-271 A3133-3693-006	51-051-0000131-3701-201	39PR132-4142-1801-536	2951-6122142-1701-611
450-900-0631H133-3404-001	29 S 101-271 D3133-3693-001	51-052-0000131-3801-201	39PR132-5142-1801-546	2951-6124142-1701-561
450-900-0631N133-3404-006	29 S 201-271 A3133-3693-106	51-053-0000131-1701-371	39PR133-1142-1801-606	2951-6125142-1701-511
451-060-0046H133-3701-201	29 S 201-271 D3133-3693-101	51-053-0000131-3701-301	39PR133-2142-1801-616	2951-6146142-1701-511
451-060-0046N133-3701-206	29 S 201-301 A3133-3402-106	51-054-0000131-3801-301	39PR133-3142-1801-626	2955-6166142-1801-541
451-061-0040H133-3711-201	29 S 201-301 D3133-3402-101	51-062-2210131-3701-801	39PR133-4142-1801-636	2955-6177142-1801-601
451-451-0000H133-3901-801	29 S 201-302 A3133-3403-106	51-075-0000131-3901-401	39PR133-5142-1801-646	2955-6178142-1801-531
451-451-0000N133-3901-806	29 S 201-302 D3133-3403-101	51-328-3188131-1403-101		2955-6197142-1801-621
451-900-0360H133-3302-001	29 S 201-303 A3133-3404-106	51-328-3188131-3403-101	SRIEMERSON	2955-6197142-1801-631
451-900-0360N133-3302-006	29 S 201-303 D3133-3404-101	51-328-3196131-1402-101	24-000-1041-90145-0694-002	2955-6297142-1801-531
451-900-0630H133-3303-001	29 Z 101-102 A3142-0003-236	51-328-3196131-3402-101	24-924-0000-90145-0901-811	2955-6298142-1801-601
451-900-0630N133-3303-006	29 Z 101-102 D3142-0003-231	55-607-0369-31142-0694-031	24-925-0000-90145-0901-821	2955-6299142-1801-621
451-900-0631H133-3304-001	29 Z 101-103 A3142-0004-216	55-607-2203-31142-0694-001	25-130-1500-90145-0701-602	2955-6299142-1801-631
451-900-0631N133-3304-006	29 Z 101-103 D3142-0004-211	55-607-3702-31142-0693-001	25-131-1500-90145-0701-612	2955-6300142-1801-641
451-980-0360H133-3302-401		55-607-9073-31142-0694-011	25-925-0000-90145-0901-801	2955-6305142-1801-611
451-980-0360N133-3302-406	SEALCTROEMERSON	55-607-9172-31142-0693-001	26-000-1085-90145-0693-002	2955-6333142-1801-611
451-980-0630H133-3303-401	50-024-0000131-6403-001	55-607-9173-31142-0694-001		2960-6001142-0701-701
451-980-0630N133-3303-406	50-027-0000131-6303-401	55-608-2002-31142-0593-001	SV MICROWAVEEMERSON	2960-6025142-1711-001
451-980-0631H133-3304-401	50-043-0000131-6701-401	55-608-2003-31142-0594-001	066-15-000142-1000-033	2960-6268142-1711-021
451-980-0631N133-3304-406	50-045-0000131-6701-411	55-608-9182-31142-0593-001	2902-6001142-0694-031	2960-6274142-1711-031
452-500-0850H133-3693-101	50-051-0000131-6701-201	55-608-9183-31142-0594-001	2902-6005142-0694-001	2960-6613142-1711-531
452-500-0850N133-3693-106	50-053-0000131-6701-301	55-610-3702-31142-0593-401	2902-6012142-0694-001	2960-6701142-1711-521
452-900-0360H133-3402-101	50-328-3188131-6403-101	55-610-3703-31142-0594-401	2902-6013142-0694-021	2960-6703142-1711-511
452-900-0360N133-3402-106	50-607-3141-31142-0207-011	55-610-9172-31142-0594-401	2903-6009142-0403-001	2970-6003142-0701-401
452-900-0630H133-3403-101	50-607-3188-31142-0203-011	55-610-9173-31142-0594-401	2906-6002142-0693-001	2975-6001142-0701-411
452-900-0630N133-3403-106	50-607-3196-31142-0202-011	55-624-3073-31142-0694-021	2911-6001142-0407-101	2990-6005142-0901-401
452-900-0631H133-3404-101	50-610-3188-31142-0103-401		2913-6001142-0403-101	2992-6001142-0901-801
452-900-0631N133-3404-106	50-610-3196-31142-0102-401	SIEMENSEMERSON	2913-6030142-0402-101	2993-6001142-0901-811
453-060-0046H133-3701-301	50-611-3141-31142-0207-101	V23608-A1027-B1135-3701-201	2921-6002142-0593-001	2997-6003142-0901-821
453-060-0046N133-3701-306	50-611-3188-31142-0203-101	V23608-A109-B1135-3402-001	2922-6007142-0594-001	SF1503-6103145-0693-002
	50-611-3196-31142-0202-101	V23608-A109-B11135-3436-001	2942-6001142-0594-401	SF1550-6400145-0701-612
ROSENBERGEREMERSON	50-622-9141-31142-0407-011	V23608-A1227-B1135-3701-301	2942-6035142-0303-401	SF1552-6002145-0701-602
02-K-521-80053145-0701-002	50-622-9142-31142-0408-011	V23608-A209-B1135-3402-101	2943-6044142-0302-401	SF1590-6000145-0901-801
02-S-121-27153142-0693-002	50-622-9188-31142-0403-011	V23608-A209-B11135-3436-101	2946-6001142-0593-401	SF1593-6000145-0901-811
02-Z-101-000142-1000-033	50-624-9188-31142-0403-001		2947-6003142-0701-531	SF1597-6003145-0901-821
29 K 100-K00 D3133-3901-801	50-627-9188-31142-0303-401	SPECIALTYEMERSON	2950-6062142-0701-621	SF2947-6003142-0701-536
29 K 101-101 A3133-3302-006	50-627-9196-31142-0302-401	39JR293-1142-1701-506	2950-6081142-0701-631	SF2950-6135142-1701-196
29 K 101-101 D3133-3302-001	50-628-9141-31142-0407-101	39JR293-2142-1701-516	2950-6135142-1701-191	SF2950-6220142-1701-016
29 K 101-102 A3133-3303-006	50-628-9188-31142-0403-101	39JR293-3142-1701-526	2950-6220142-1701-011	SF2950-6336142-1701-206
29 K 101-102 D3133-3303-001	50-628-9196-31142-0402-101	39JR293-4142-1701-536	2950-6336142-1701-201	SF2950-6619142-1701-506
29 K 101-103 A3133-3304-006	50-643-0000-31142-0701-401	39JR293-5142-1701-546	2950-6619142-1701-501	SF2950-6662142-1701-526
29 K 101-103 D3133-3304-001	50-643-4312-31142-0701-411	39JR294-1142-1701-606	2950-6662142-1701-521	SF2950-6662142-1701-536
29 K 101-400 A3133-3701-206	50-645-4504-31142-0701-631	39JR294-2142-1701-616	2950-6662142-1701-531	SF2950-6720142-1701-606
29 K 101-400 D3133-3701-201	50-645-4526-31142-0701-621	39JR294-3142-1701-626	2950-6720142-1701-601	SF2950-6731142-1701-546
29 K 101-K00 A3133-3901-806	50-651-0000-31142-0701-201	39JR294-4142-1701-636	2950-6731142-1701-541	SF2950-6769142-1701-506
29 K 104-400 A3133-3701-236	50-652-0000-31142-0801-201	39JR294-5142-1701-646	2950-6769142-1701-501	SF2950-6780142-1701-626
29 K 104-400 D3133-3701-231	50-653-0000-31142-0701-301	39JR295-1142-1701-506	2950-6780142-1701-621	SF2950-6780142-1701-636
29 K 203-400 A3133-3701-306	50-654-0000-31142-0801-301	39JR295-2142-1701-516	2950-6780142-1701-631	SF2950-6781142-1701-646

Competitor Cross Reference

Ultra Miniature Connectors UMC to U.FL Cross Reference

Emerson	Hirose
128-0711-201	U.FL-R-SMT(10)
415-0084-050	U.FL-2LP(V)-04N1-A-50
415-0084-100	U.FL-2LP(V)-04N1-A-100
415-0084-150	U.FL-2LP(V)-04N1-A-150
415-0084-200	U.FL-2LP(V)-04N1-A-200
415-0084-250	U.FL-2LP(V)-04N1-A-250
415-0084-300	U.FL-2LP(V)-04N1-A-300
415-0084-500	U.FL-2LP(V)-04N1-A-500
415-0085-050	U.FL-2LP-04N2-A-50
415-0085-100	U.FL-2LP-04N2-A-100
415-0085-150	U.FL-2LP-04N2-A-150
415-0085-200	U.FL-2LP-04N2-A-200
415-0085-250	U.FL-2LP-04N2-A-250
415-0085-300	U.FL-2LP-04N2-A-300
415-0085-300	U.FL-2LP-04N2-A-500
415-0086-050	U.FL-2LP-068N2-A-50
415-0086-100	U.FL-2LP-068N2-A-100
415-0086-150	U.FL-2LP-068N2-A-150
415-0086-200	U.FL-2LP-068N2-A-200
415-0086-250	U.FL-2LP-068N2-A-250
415-0086-300	U.FL-2LP-068N2-A-300
415-0086-500	U.FL-2LP-068N2-A-500
415-0087-050	U.FL-2LP-066J2-A-50

Emerson	Hirose
415-0087-100	U.FL-2LP-066J2-A-100
415-0087-150	U.FL-2LP-066J2-A-150
415-0087-200	U.FL-2LP-066J2-A-200
415-0087-250	U.FL-2LP-066J2-A-250
415-0087-300	U.FL-2LP-066J2-A-300
415-0087-500	U.FL-2LP-066J2-A-500
415-0088-050	U.FL-2LP-088K2T-A-50
415-0088-100	U.FL-2LP-088K2T-A-100
415-0088-150	U.FL-2LP-088K2T-A-150
415-0088-200	U.FL-2LP-088K2T-A-200
415-0088-250	U.FL-2LP-088K2T-A-250
415-0088-300	U.FL-2LP-088K2T-A-300
415-0088-500	U.FL-2LP-088K2T-A-500
415-0104-150	U.FL-LP(V)-04N1-A-150
415-0104-250	U.FL-LP(V)-04N1-A-250
415-0105-150	U.FL-LP-04N2-A-150
415-0105-250	U.FL-LP-04N2-A-250
415-0106-150	U.FL-LP-068N2-A-150
415-0106-250	U.FL-LP-068N2-A-250
415-0107-150	U.FL-LP-066J2-A-150
415-0107-250	U.FL-LP-066J2-A-250
415-0108-150	U.FL-LP-088K2T-A-150
415-0108-250	U.FL-LP-088K2T-A-25

Competitor Cross Reference

Type N Competitor Cross Reference

Emerson	Radiall	M/A-Com	Amphenol	Tyco/Amp	Telegartner	Rosenberger	Huber-Suhner
138-4303-407	R161311300	3004-7388-10	82-6156			53K507-802N3	
138-4304-407	R161311300					53K507-803N3	
138-4307-407	R161329000	3004-7341-10	82-5378	1-225667-2	J01021A0147	53K507-106N3	24N-50-3-11C
138-4308-407	R161329200	3004-7341-10	82-5373	225363-2	J01021A0148	53K507-108N3	24N-50-3-12C
138-4316-407	R161331000	N15H61H001X99	82-346-RFX	225094-2	J01021A0060	53K501-115N3	24N-50-7-14C
138-4318-407	R161331200	N15H61H004X99		225667-1	J01021A0092	53K501-117N3	24N-50-7-15C
138-4349-407	R161331060		82-6143-1000				
138-4403-007	R161072000	3031-7338-10			J01020A0103	53S107-802N3	
138-4403-107	R161181000		82-6048-1000		J01020A0040		
138-4404-007	R161072000				J01020A0104	53S107-803N3	
138-4404-107	R161181300				J01020A0039		
138-4407-007	R161082000	3031-7358-10	82-5375	1-225661-2	J01010A0108	53S107-106N3	11N-50-3-28C
138-4407-107	R161182000			1-225669-2	J01020A0035	53S205-315N3	16N-50-3-26C
138-4408-007	R161083000	3031-7341-10	82-5370	225699-1	J01020A0113	53S107-108N3	11N-50-3-29C
138-4408-107	R161183000		82-4442	225365-2	J01020A0036	53S205-317N3	16N-50-3-27C
138-4416-007	R161075000	N15A61H001X99	82-340	225661-2	J01020A0107	53S101-115N3	11N-50-7-43C
138-4416-107	R161184000	N15B61H001X99	82-336	225669-2	J01020A0046		16N-50-7-30C
138-4418-007	R161088000	N15A61H004X99	82-332	225661-1	J01020A0110	53S101-115N3	11N-50-7-44C
138-4418-107	R161186000	N15B61H004X99	82-4440-1001	225669-1	J01020A0045		16N-50-7-31C
138-4449-007	R161075060		82-340-1052		J01020A0127	53S101-1N9N3	
138-4593-401	R161335200	3004-7985-00	82-6093-RFX	228658-2	J01021H0087	52K504-271N3	24N-50-2-14
138-4594-401	R161336000	3004-7941-00	82-6097-RFX	228658-1	J01021A0151	53K504-272N3	24N-50-3-14
138-4596-401	R161337200		82-6162		J01021A0109	53K504-273N3	24N-50-5-39C
138-4693-001	R161050300	3001-7985-00		1057094-1			11N-50-2-14
138-4693-011	R161050300	3001-7985-00					11N-50-2-14
138-4694-001	R161051000	3001-7941-00	82-5955-RFX	1057088-1	J01020A0109	53S101-272B1	11N-50-3-13
138-4694-011	R161051000	3001-7941-00	82-5955-RFX		J01020A0109	53S101-272B1	11N-50-3-13
138-4696-001	R161054000		82-6124		J01020A0112	53S101-273B1	11N-50-5-39C
138-4696-011	R161054000		82-6124		J01020A0112	53S101-273B1	11N-50-5-39C
138-4701-407	R161586137	N15M35999X99			J01021A1084	53K505-200N3	
138-4701-607	R161404000	3052-0000-10	82-97	1-1337418-0	J01021A1082	53K401-200N3	23N-50-0-23
138-4901-407	R161730000	N15R07999X99	82-66		J01024A1088	53K501-K00N3	34N-50-0-51
138-4901-807	R161705000	3680-0000-02	82-101	227945-2	J01024A1092	53K101-K00N3	31N-50-0-51
138-4901-817	R161703000	3681-0000-02	82-100	1058661-1	J01024A1094	53K101-S00N3	32N-50-0-51

**Emerson Network Power Connectivity Solutions, Inc.,
including its subsidiaries Stratos International, Inc., Trompeter Electronics, Inc., and Semflex, Inc.**

TERMS AND CONDITIONS OF SALE

Emerson Network Power Connectivity Solutions, Inc. is herein referred to as the "Seller" and the customer or person or entity purchasing goods ("Goods") from Seller is referred to as the "Buyer." These Terms and Conditions, any price list or schedule, quotation, acknowledgment or invoice from Seller relevant to the sale of the Goods and all documents incorporated by specific reference herein or therein, constitute the complete and exclusive statement of the terms of the agreement governing the sale of Goods by Seller to Buyer. Buyer's acceptance of the Goods will manifest Buyer's assent to these Terms and Conditions. Seller reserves the right in its sole discretion to refuse orders.

1. PRICES: Unless otherwise specified in writing by Seller, the price quoted or specified by Seller for the Goods shall remain in effect for thirty (30) days after the date of Seller's quotation or acknowledgment of Buyer's order for the Goods, whichever occurs first, provided an unconditional authorization from Buyer for the shipment of the Goods is received and accepted by Seller within such time period. If such authorization is not received by Seller within such thirty (30) day period, Seller shall have the right to change the price for the Goods to Seller's price for the Goods at the time of shipment. All prices are exclusive of taxes, transportation and insurance, which are to be borne by Buyer.

2. TAXES: Any current or future tax or governmental charge (or increase in same) affecting Seller's costs of production, sale, or delivery or shipment, or which Seller is otherwise required to pay or collect in connection with the sale, purchase, delivery, storage, processing, use or consumption of Goods, shall be for Buyer's account and shall be added to the price.

3. TERMS OF PAYMENT: Unless otherwise specified by Seller, terms are net thirty (30) days from date of Seller's invoice in U.S. currency. Seller shall have the right, among other remedies, either to terminate this agreement or to suspend further performance under this and/or other agreements with Buyer in the event Buyer fails to make any payment when due, which other agreements Buyer and Seller hereby amend accordingly. Buyer shall be liable for all expenses, including attorneys' fees, relating to the collection of past due amounts. If any payment owed to Seller is not paid when due, it shall bear interest, at a rate to be determined by Seller, which shall not exceed the maximum rate permitted by law, from the date on which it is due until it is paid. Should Buyer's financial responsibility become unsatisfactory to Seller, cash payments or security satisfactory to Seller may be required by Seller for future deliveries and for the Goods theretofore delivered. If such cash payment or security is not provided, in addition to Seller's other rights and remedies, Seller may discontinue deliveries.

4. SHIPMENT AND DELIVERY: While Seller will use all reasonable commercial efforts to maintain the delivery date(s) acknowledged or quoted by Seller, all shipping dates are approximate and not guaranteed. Seller reserves the right to make partial shipments. Seller, at its option, shall not be bound to tender delivery of any Goods for which Buyer has not provided shipping instructions and other required information. If the shipment of the Goods is postponed or delayed by Buyer for any reason, Buyer agrees to reimburse Seller for any and all storage costs and other additional expenses resulting therefrom. Risk of loss and legal title to the Goods shall transfer to Buyer for sales in which the end destination of the Goods is outside of the United States immediately after the Goods have passed beyond the territorial limits of the United States. For all other shipments, risk of loss for damage and responsibility shall pass from Seller to Buyer upon delivery to and receipt by carrier at Seller's shipping point. All shipments are F.O.B. Seller's shipping point. Any claims for shortages or damages suffered in transit are the responsibility of Buyer and shall be submitted by Buyer directly to the carrier.

Shortages or damages must be identified and signed for at the time of delivery. Buyer shall inspect Goods delivered to it by Seller immediately upon receipt, and, any course of dealing to the contrary notwithstanding, failure of Buyer to give Seller notice of any claim within 30 days after receipt of such Goods shall be an unqualified acceptance of such Goods.

5. LIMITED WARRANTY: Subject to the limitations of Section 6, Seller warrants that the Goods manufactured by Seller will be free from defects in material and workmanship under normal use and regular service and maintenance for a period of one year from the date of shipment of the Goods by Seller, unless otherwise specified by Seller in writing. **THIS IS THE SOLE AND EXCLUSIVE WARRANTY GIVEN BY SELLER WITH RESPECT TO THE GOODS AND IS IN LIEU OF AND EXCLUDE ALL OTHER WARRANTIES, EXPRESS OR IMPLIED, ARISING BY OPERATION OF LAW OR OTHERWISE, INCLUDING WITHOUT LIMITATION, MER-**

CHANTABILITY AND FITNESS FOR A PARTICULAR PURPOSE WHETHER OR NOT THE PURPOSE OR USE HAS BEEN DISCLOSED TO SELLER IN SPECIFICATIONS, DRAWINGS OR OTHERWISE, AND WHETHER OR NOT SELLER'S PRODUCTS ARE SPECIFICALLY DESIGNED AND/OR MANUFACTURED BY SELLER FOR BUYER'S USE OR PURPOSE.

This warranty does not extend to any losses or damages due to misuse, accident, abuse, neglect, normal wear and tear, negligence (other than Seller's), unauthorized modification or alteration, use beyond rated capacity, unsuitable power sources or environmental conditions, improper installation, repair, handling, maintenance or application or any other cause not the fault of Seller. To the extent that Buyer or its agents has supplied specifications, information, representation of operating conditions or other data to Seller in the selection or design of the Goods and the preparation of Seller's quotation, and in the event that actual operating conditions or other conditions differ from those represented by Buyer, any warranties or other provisions contained herein which are affected by such conditions shall be null and void.

If within thirty (30) days after Buyer's discovery of any warranty defects within the warranty period, Buyer notifies Seller thereof in writing, Seller shall, at its option and as Buyer's exclusive remedy, repair, correct or replace F.O.B. point of manufacture, or refund the purchase price for, that portion of the Goods found by Seller to be defective. Failure by Buyer to give such written notice within the applicable time period shall be deemed an absolute and unconditional waiver of Buyer's claim for such defects. All costs of dismantling, reinstallation and freight and the time and expense of Seller's personnel and representatives for site travel and diagnosis under this warranty shall be borne by Buyer unless accepted in writing by Seller. Goods repaired or replaced during the warranty period shall be covered by the foregoing warranty for the remainder of the original warranty period or ninety (90) days from the date of shipment, whichever is longer.

Buyer assumes all other responsibility for any loss, damage, or injury to persons or property arising out of, connected with, or resulting from the use of Goods, either alone or in combination with other products/components.

Section 5 applies to any entity or person who may buy, acquire or use the Goods, including any entity or person who obtains the Goods from Buyer, and shall be bound by the limitations therein, including Section 6. Buyer agrees to provide such subsequent transferee conspicuous, written notice of the provisions of Sections 5 and 6.

6. LIMITATION OF REMEDY AND LIABILITY: THE SOLE AND EXCLUSIVE REMEDY FOR BREACH OF ANY WARRANTY HEREUNDER OTHER THAN THE WARRANTY PROVIDED UNDER SECTION 7 SHALL BE LIMITED TO REPAIR, CORRECTION OR REPLACEMENT, OR REFUND OF THE PURCHASE PRICE UNDER SECTION 5.

SELLER SHALL NOT BE LIABLE FOR DAMAGES CAUSED BY DELAY IN PERFORMANCE AND THE REMEDIES SET FORTH IN THIS AGREEMENT ARE EXCLUSIVE. IN NO EVENT, REGARDLESS OF THE FORM OF THE CLAIM OR CAUSE OF ACTION (WHETHER BASED IN CONTRACT, INFRINGEMENT, NEGLIGENCE, STRICT LIABILITY, OTHER TORT OR OTHERWISE), SHALL SELLER'S LIABILITY TO BUYER AND/OR ITS CUSTOMERS EXCEED THE PRICE PAID BY BUYER FOR THE SPECIFIC GOODS PROVIDED BY SELLER GIVING RISE TO THE CLAIM OR CAUSE OF ACTION. BUYER AGREES THAT IN NO EVENT SHALL SELLER'S LIABILITY TO BUYER AND/OR ITS CUSTOMERS EXTEND TO INCLUDE INCIDENTAL, CONSEQUENTIAL OR PUNITIVE DAMAGES. The term "consequential damages" shall include, but not be limited to, loss of anticipated profits, business interruption, loss of use, revenue, reputation and data, costs incurred, including without limitation, for capital, fuel, power and loss or damage to property or equipment.

Buyer expressly acknowledges and agrees that Seller has set its prices and entered into this agreement in reliance upon the limitations of liability and other terms and conditions specified herein, which allocates the risk between Seller and Buyer and form a basis of this bargain between the parties.

It is expressly understood that any technical advice furnished by Seller with respect to the use of the Goods is given without charge, and Seller assumes no obligation or liability for the advice given, or results obtained, all such advice being given and accepted at Buyer's risk.

7. PATENTS AND COPYRIGHTS: Subject to the limitations of the second



EMERSON™

Network Power

Connectivity Solutions

Emerson Network Power Connectivity Solutions

US Headquarters

3000 Lakeside Drive, Ste. 308N
Bannockburn, IL 60015, USA

North America

299 Johnson Avenue, Ste. 100
Waseca, MN 56093, USA
Toll Free: 800.247.8256

Tel: 507.833.8822

Fax: 507.833.6287

ECOrders@Emerson.com

Europe, Middle East, Africa

Emerson Network Power Connectivity Solutions, Ltd.
11 Bilton Road
Chelmsford
Essex CM1 2UP
England

Tel: +44 1245.359.515

Fax: +44 1245.358.938

EMEACConnectivitySales@Emerson.com

Asia Pacific

Emerson Network Power Connectivity Solutions
(Shanghai) Co., Ltd.

Building 1, No. 800 ShenFu Road
XinZhuang Industry Park
Shanghai, China 201108

Tel: +86 21.5442.7668

Fax: +86 21.5442.7628

APConnectivitySales@Emerson.com

About Emerson Network Power Connectivity Solutions

Emerson Network Power Connectivity Solutions, an Emerson business, serves the needs of wireless communications, military, telephony and data networks, CATV security systems, health care and industrial facilities with a full spectrum of RF/microwave and fiber optic connectivity products. For more information, visit www.EmersonConnectivity.com

About Emerson

Emerson (NYSE: EMR), based in St. Louis, Missouri (USA), is a global leader in bringing technology and engineering together to provide innovative solutions for customers in industrial, commercial, and consumer markets around the world. The company is comprised of five business segments: Process Management, Industrial Automation, Network Power, Climate Technologies, and Commercial & Residential Solutions. For more information, visit www.Emerson.com



www.EmersonConnectivity.com

www.EmersonNetworkPower.com/Connectivity

Emerson Network Power

The global leader in enabling business-critical continuity.

- AC Power Systems
- Embedded Power
- Outside Plant
- Connectivity
- Inbound Power
- Precision Cooling
- DC Power Systems
- Integrated Cabinet
- Site Monitoring and Services

X-ON Electronics

Largest Supplier of Electrical and Electronic Components

Click to view similar products for [Punches & Dies](#) category:

Click to view products by [Bel Fuse](#) manufacturer:

Other Similar products are found below :

[58510-1](#) [63454-1601](#) [63457-0056](#) [63457-3401](#) [730-5/8](#) [730BB-1-3/8](#) [PV-670508-001](#) [1328](#) [1338](#) [13782656](#) [13782673](#) [13782686](#) [AR-24](#)
[1528-TL](#) [1583609-1](#) [1720](#) [1762951-1](#) [2063500-2](#) [19031-0168](#) [AR-20](#) [CD5-8](#) [313336-3](#) [11-19-3122](#) [539663-1](#) [63446-2241](#) [TL-18](#)
[0634451912](#) [1762674-1](#) [63454-0123](#) [68240-1](#) [68247-1](#) [734252](#) [313183-1](#) [PA2029](#) [119174-001](#) [23846-1](#) [11-40-5342](#) [68010-2](#) [690370015](#)
[730BB-1-1/8](#) [730BB-1-1/16](#) [19032-0048](#) [63465-0023](#) [11-40-4438](#) [63457-0041](#) [2906252-01](#) [19032-0202](#) [11-11-0054](#) [11-11-0052](#) [19813-](#)
[5041](#)