

PART NUMBER	ITEM ① BODY	ITEM ② CONTACT	ITEM ③ INSULATOR
142-0594-601	BRASS GOLD PL .00001 MIN OVER NICKEL PL .00005 MIN OVER COPPER	BERYLLIUM COPPER GOLD PL .00005 MIN OVER NICKEL PL .00005 MIN OVER COPPER	TEFLON

REV	ECO	DATE
1	INITIAL RELEASE	11/18/2021

NOTES:

1. ELECTRICAL SPECIFICATIONS:

- 1.1 IMPEDANCE: 50 OHMS
- 1.2 FREQUENCY RANGE: 0-18 GHz
- 1.3 VSWR: 1.50 MAX
- 1.4 WORKING VOLTAGE: 500 VRMS MAX AT SEA LEVEL
- 1.5 DIELECTRIC WITHSTANDING VOLTAGE: 1500 VRMS MIN AT SEA LEVEL
- 1.6 INSULATION RESISTANCE: 5000 MEGOHM MIN
- 1.7 CONTACT RESISTANCE:
  - 1.7.1 CENTER CONTACT - INITIAL 3.0 MILLIOHM MAX, AFTER ENVIRONMENTAL 4.0 MILLIOHM MAX
  - 1.7.2 OUTER CONDUCTOR - INITIAL 2.0 MILLIOHM MAX, AFTER ENVIRONMENTAL NOT APPLICABLE
- 1.8 CORONA LEVEL: 375 VOLTS MINIMUM AT 70,000 FEET
- 1.9 INSERTION LOSS:  $.03 * \sqrt{F}$  MAX (F IN GHz) AT 10 GHz
- 1.10 RF LEAKAGE: -90 DB MIN AT 2 TO 3 GHz
- 1.11 RF HIGH POTENTIAL WITHSTANDING VOLTAGE: 1000 VRMS MIN AT 5 AND 7.5 MHz

2. MECHANICAL SPECIFICATIONS:

- 2.1 ENGAGE/DISENGAGE TORQUE: 2 IN LBS MAX
- 2.2 MATING TORQUE: 7-10 IN LBS
- 2.3 CABLE ACCEPTABILITY: RG402 DIA .141 SEMIRIGID
- 2.4 CABLE RETENTION: 60 LBS MIN AXIAL FORCE  
55 INCH-OUNCE MIN TORQUE
- 2.5 DURABILITY: 500 CYCLES MIN

3. ENVIRONMENTAL:

(MEETS OR EXCEEDS THE APPLICABLE PARAGRAPH OF MIL-PRF-39012)

- 3.1 THERMAL SHOCK: MIL-STD-202, METHOD 107, CONDITION B, EXPECT 115°C HIGH TEMP
- 3.2 OPERATING TEMPERATURE: -65 °C TO 165 °C
- 3.3 CORROSION: MIL-STD-202, METHOD 101, CONDITION B
- 3.4 SHOCK: MIL-STD-202, METHOD 213, CONDITION I
- 3.5 VIBRATION: MIL-STD-202, METHOD 204, CONDITION D
- 3.6 MOISTURE RESISTANCE: MIL-STD-202, METHOD 106

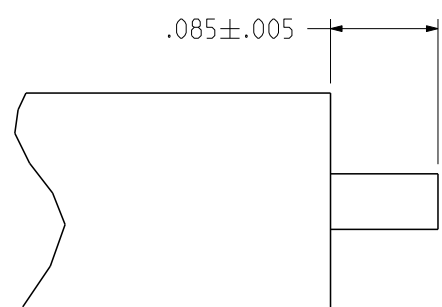
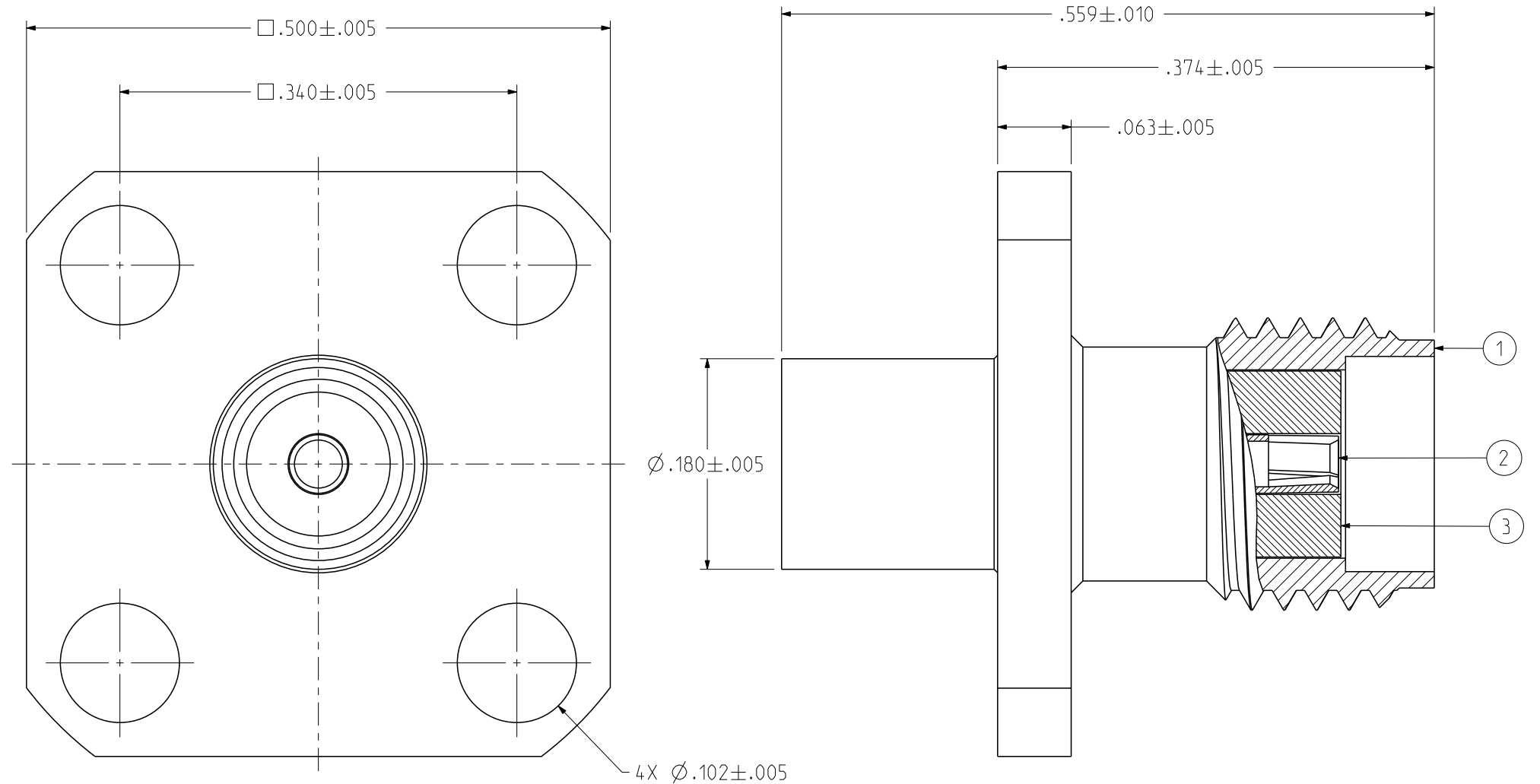

CABLE STRIP DIMENSIONS

	Model No: 142-0594-601/610	JOHNSON	
	RoHS <input checked="" type="checkbox"/> (EU)/2015/863 COMPLIANT UNLESS OTHERWISE SPECIFIED UNITS: INCH .XX ± .01 .XXX ± .003 .XXXX ± .0010 ANGLE ± 2°	Title: SMA JACK ASSEMBLY, 4 HOLE FLANGE STRAIGHT CABLED, RG 402 Drawing No. 142-0594-601/610 Date: 11/18/2021	REV. 4 DO NOT SCALE DRAWING Workmanship Std: SHEET NONE 1 OF 1

## X-ON Electronics

Largest Supplier of Electrical and Electronic Components

*Click to view similar products for [RF Connectors / Coaxial Connectors](#) category:*

*Click to view products by [Bel Fuse](#) manufacturer:*

Other Similar products are found below :

[89674-0827](#) [6059674-1](#) [630059-000](#) [6501-1071-002](#) [6769](#) [7002-1541-010](#) [7002-1572-002](#) [7004-1512-000](#) [7009-1511-004](#) [7101-1541-010](#)  
[7101-1571-002](#) [7105-1521-002](#) [7203-1571-003](#) [7209-1511-011](#) [7210-1511-040](#) [7242-1511-000](#) [7405-1521-005](#) [7405-1521-802](#)  
[804S01D04M040](#) [8527](#) [8547](#) [FS11V](#) [877931](#) [8808-1511-001](#) [9049-9513-000](#) [9074-9513-000](#) [PL11C-026](#) [PL40-36](#) [9408-1113-000](#) [980-](#)  
[8666-005](#) [11 SMA-50-2-6 / 111 NE](#) [11 SMA-50-3-6 / 111 NE](#) [1-201144-1](#) [120919](#) [R107003010W](#) [R112186000](#) [R113053000W](#) [R113082097](#)  
[R113236000](#) [R114083000](#) [R114670000W](#) [R123415000W](#) [R124076320](#) [R124076450](#) [R124175123](#) [R125075000W](#) [R125075001](#)  
[R125172000W](#) [R125415030](#) [R141007161](#)