

SMK - 50 Ohm Connectors (2.92mm)

INCHES (MILLIMETERS) • CUSTOMER DRAWINGS AVAILABLE UPON REQUEST



Jack to Jack In-Series Adapter



GOLD PLATED
145-0901-801

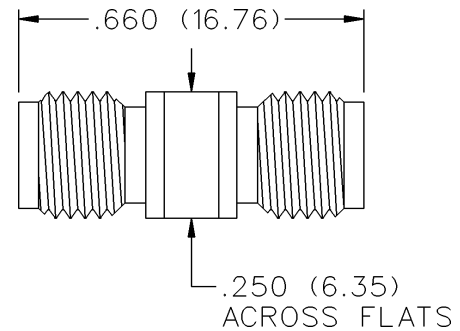

MATERIAL SPECIFICATIONS

Bodies: Stainless steel per QQ-B-626, gold plated* per MIL-G-45204
 .00005" min. or passivated per MIL-F-14072 B (EL) 300

Contacts:

Female - beryllium copper per QQ-C-530, gold plated per MIL-G-45204
 .00005" min.

Contact Support Beads: PTFE fluorocarbon per ASTM D 1710 and
 ASTM D 1457 or modified PPE resin

Seal Rings: Silicone rubber per ZZ-R-765

* All gold plated parts include a .00005" min. nickel underplate barrier layer.

MECHANICAL RATINGS

Engagement Design: MIL-STD-348, Series SMK (2.92mm)

Engagement/Disengagement Force: 2 inch-pounds maximum

Mating Torque: 7 to 10 inch-pounds

Coupling Proof Torque: 15 inch-pounds minimum

Coupling Nut Retention: 60 pounds minimum

Contact Retention: 6 lbs. minimum axial force (captivated contacts)

Cable Retention:	Axial Force*(lbs)	Torque (in-oz)
.086 semi-rigid	30	16
.141 semi-rigid	60	55

*Or cable breaking strength whichever is less.

Durability: 500 cycles minimum

Notes:

1. ID of contact shall meet VSWR and connectivity requirements when mated with dia. .0355-.0365 male pin.

Mating Engagement for SMK (2.92mm) Series per MIL-STD-348

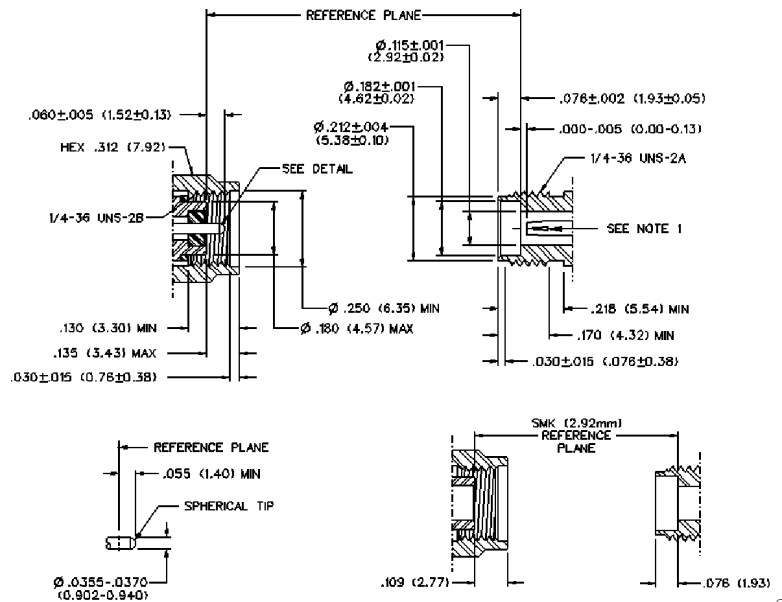

SMK - 50 Ohm Connectors (2.92mm)

INCHES (MILLIMETERS) · CUSTOMER DRAWINGS AVAILABLE UPON REQUEST



ELECTRICAL RATINGS

Impedance: 50 ohms
 Frequency Range: 0-40 GHz
 VSWR: (f = GHz)
 Semi-rigid straight cabled connectors and adapters 1.20 Max
 Field replaceable (see typical return loss graph) N/A
 Working Voltage: (Vrms maximum)
 Connectors for Cable Type Sea Level 70K Feet
 .086 semi-rigid and field replaceable 335 85
 .141 semi-rigid and adapters 500 125
 Dielectric Withstanding Voltage: (VRMS minimum at sea level)
 .086 semi-rigid and field replaceable 1000
 .141 semi-rigid and adapters 1500
 Corona Level: (Volts minimum at 70,000 feet)
 .086 semi-rigid and field replaceable 250
 .141 semi-rigid and adapters 375
 Insertion Loss: (dB maximum)
 Adapters 0.06 f(GHz), tested at 6 GHz
 Straight semi-rigid cable connectors 0.03 f(GHz), tested at 10 GHz
 Insulation Resistance: 5000 megohms minimum
 Contact Resistance: (milliohms maximum) Initial After Environmental
 Center contact straight cabled connectors ... 3.0* 4.0
 Center contact adapters 4.0 6.0
 Field replaceable connectors 6.0 8.0
 Outer contact (all connectors) 2.0 N/A
 Body to cable (gold plated connectors) 0.5 N/A
 Body to cable (passivated connectors) 5.0 N/A
 RF Leakage: (dB minimum, tested at 2.5 GHz) -90dB
 RF High Potential Withstanding Voltage: (Vrms minimum, tested at 4 and 7 MHz) =
 .086 semi-rigid and field replaceable 670
 .141 semi-rigid and adapters 1000

ENVIRONMENTAL RATINGS

(Meets or exceeds the applicable paragraph of MIL-C-39012)

Temperature Range: -65 °C to + 165 °C
 Thermal Shock: MIL-STD-202, Method 107, Condition B
 Corrosion: MIL-STD-202, Method 101, Condition B
 Shock: MIL-STD-202, Method 213, Condition I
 Vibration: MIL-STD-202, Method 204, Condition D
 Moisture Resistance: MIL-STD-202, Method 106

FIELD REPLACEABLE APPLICATION NOTES

The field replaceable connectors manufactured by Johnson Components are easy to install and replace. The hermetic seal is mounted into the circuit module wall and the connector can be removed and replaced without destroying the hermeticity of the circuit housing.

The field replaceable connector creates a transition from microstrip circuitry to a coaxial transmission line. The SMK (2.92mm) seal pin diameter is .012 (.030) to minimize the capacitive effects on the circuit trace. For optimum electrical performance, the transition from the hermetic seal to the microstrip trace must be properly compensated. Compensation involves adjusting the microstrip trace width to minimize any impedance discontinuities found in the transition area.

The plot shown below is representative of the typical return loss of a Johnson Components field replaceable SMK connector. To produce the data shown below, a test fixture is created using the Johnson Components SMK hermetic seal. The fixture consists of a suitably thick spacer plate with the hermetic seal mounted flush to both surfaces. Two connectors are mounted back to back around the fixture and the VSWR of this test assembly is measured. The calculated return loss trace shown is equivalent to the square root of the measured VSWR of the test assembly. Since the connectors tested are of identical design, it can be stated with fair accuracy that the calculated data shown represents the response of a single field replaceable connector and its transition to the hermetic seal.

Although Johnson Components does not publish a VSWR specification for field replaceable connectors, typical connector return loss can be expected to be less than -20 dB through 40 GHz. A VSWR specification is not stated because an industry standard method for testing field replaceable connectors does not exist. The actual performance of the connector is dependent upon the following:

1. For optimum electrical performance, Johnson Components recommends the use of our standard 142-1000-033 hermetic seal with a pin diameter of .0120 (0.305) +/- .0005 (0.013).
2. It is recommended that the hermetic seal be mounted flush with the circuit housing. Tolerance variations between the hermetic seal and machined housing do not always guarantee an optimum transition to the connector. Some manufacturers recommend an additional counterbore in the circuit housing to accommodate a solder washer during installation of the seal. Johnson Components does not recommend this type of installation because if the counterbore is not completely filled with solder, electrical discontinuities may be created.
3. The transition between the hermetic seal pin and the microstrip trace will effect electrical performance, as stated above. Several different methods of hermetic seal mounting and seal pin to microstrip trace attachment are used in the industry.

FIELD REPLACEABLE TEST ASSEMBLY

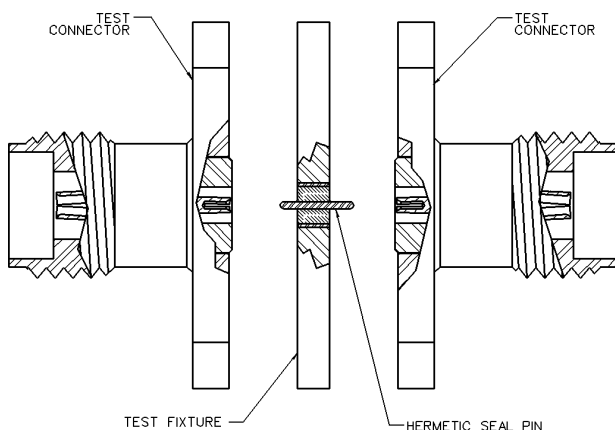

TYPICAL RETURN LOSS

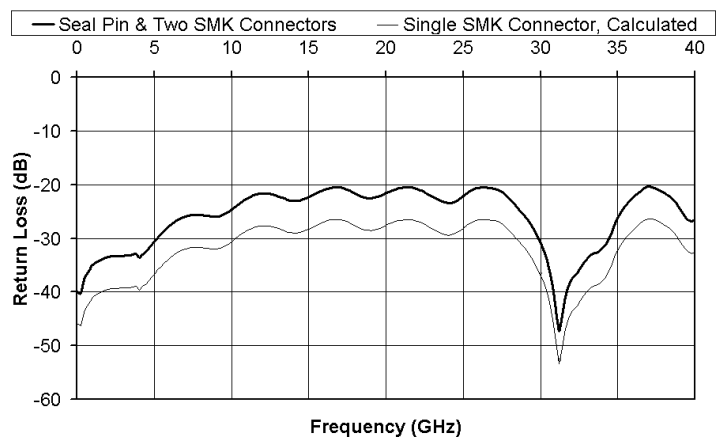

X-ON Electronics

Largest Supplier of Electrical and Electronic Components

Click to view similar products for [RF Adapters - In Series category:](#)

Click to view products by [Bel Fuse manufacturer:](#)

Other Similar products are found below :

[5918-1103-000](#) [5919-9503-000](#) [651A505](#) [R114703000W](#) [R222M40050](#) [1996352-2](#) [2157155-1](#) [252169-75](#) [AD158](#) [2101130-1](#) [252186](#)
[R125771001W](#) [R127703001](#) [R127753000](#) [R127.870.001](#) [R142710000](#) [R142723000](#) [R161715000W](#) [R405005000](#) [BJ38](#) [5928-9503-000](#)
[5919-9503-003](#) [R164705000](#) [56S201-K00N5](#) [R222M40080](#) [R125513001](#) [R124720003W](#) [R222970000W](#) [R142723000W](#) [19K119-K38L5](#)
[CT3393](#) [R222M40060](#) [05S121-S00S3](#) [05K121-K00S3](#) [1757092-1](#) [4-1532004-7](#) [033-0219-0001](#) [BU-P4290-NS](#) [920-56](#) [R143753000W](#)
[R223703080W](#) [9176-9113-000](#) [7222-1501-000](#) [R222M40107](#) [R114009000](#) [AD48](#) [ADP-NF-NF](#) [TEC0106-01](#) [ADP-SMAM-SMAFRP](#)
[ADAPT/SMAM/SMAM/RP](#)