

THIS DRAWING AND THE SUBJECT MATTER SHOWN THEREON ARE CONFIDENTIAL AND THE PROPERTY OF BEL/STEWART/TRP CONNECTOR AND SHALL NOT BE REPRODUCED, COPIED, OR USED IN ANY MANNER WITHOUT THE WRITTEN CONSENT OF TRP CONNECTOR.

PRODUCT MAY BE PROTECTED BY ONE OR MORE OF THE FOLLOWING US PATENTS:  
 5736910 5939955 6425781 6428361 6554638 6840817 7123117  
 7429195 7717749 7808751 6217391 6149050 7924130

REVISIONS				
#	LTN	DESCRIPTION	DATE	APP'D
2		EC-1411035 COMPANY LOGO CHANGE	04JAN2015	DP TY

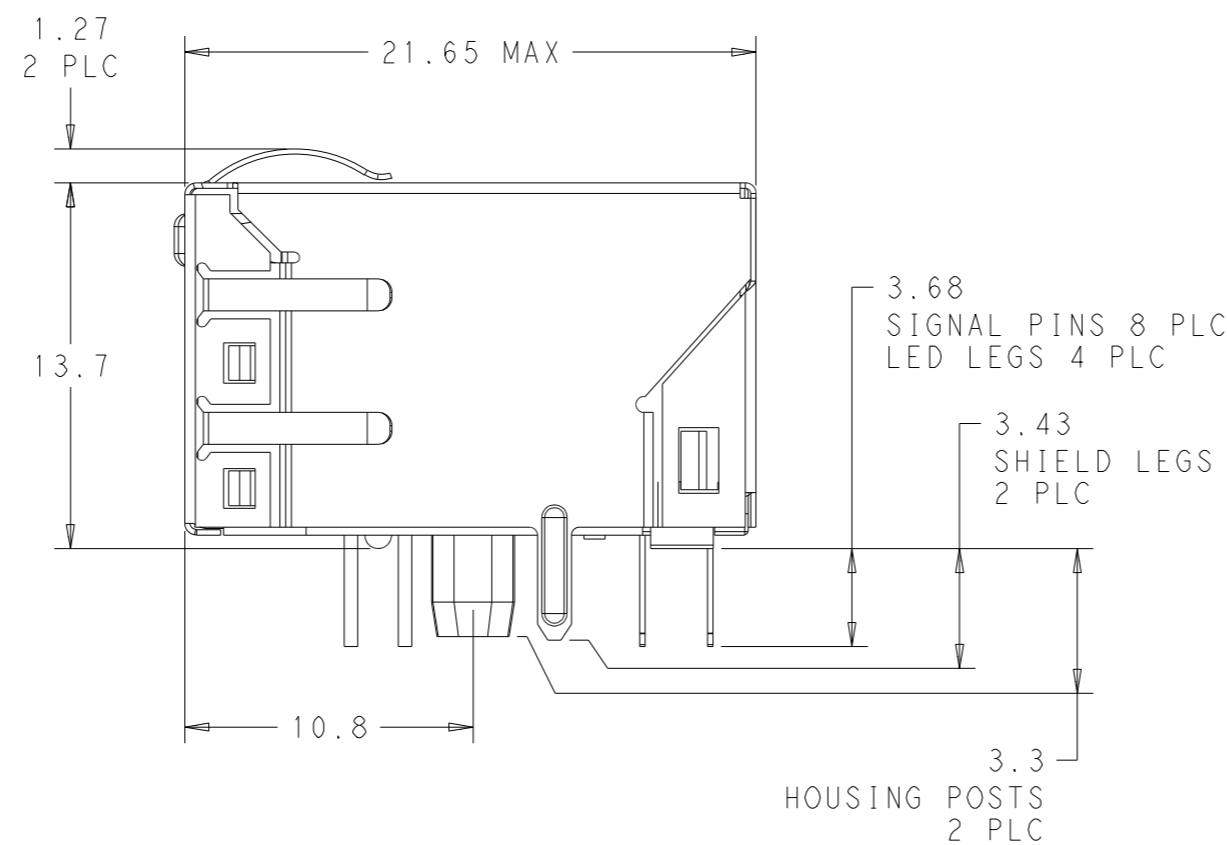
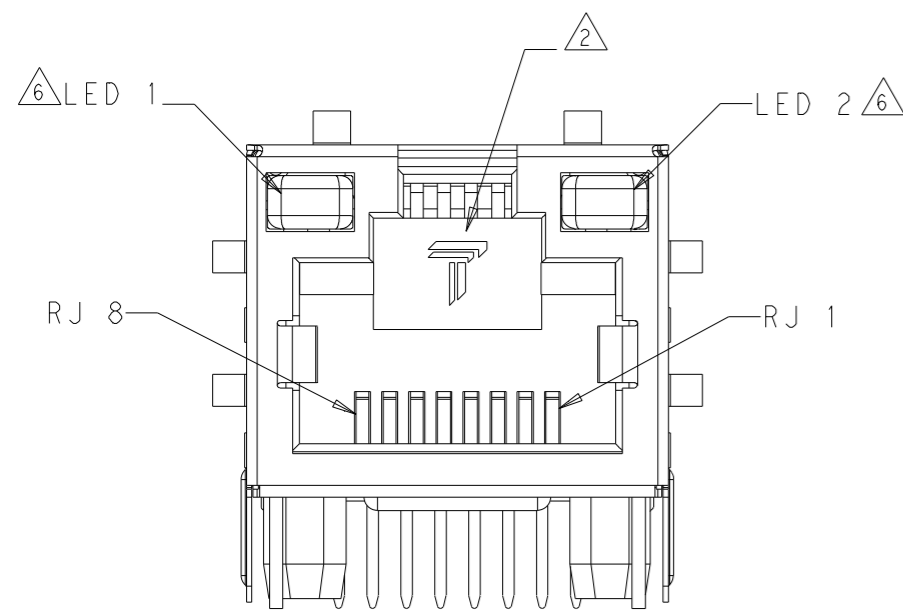
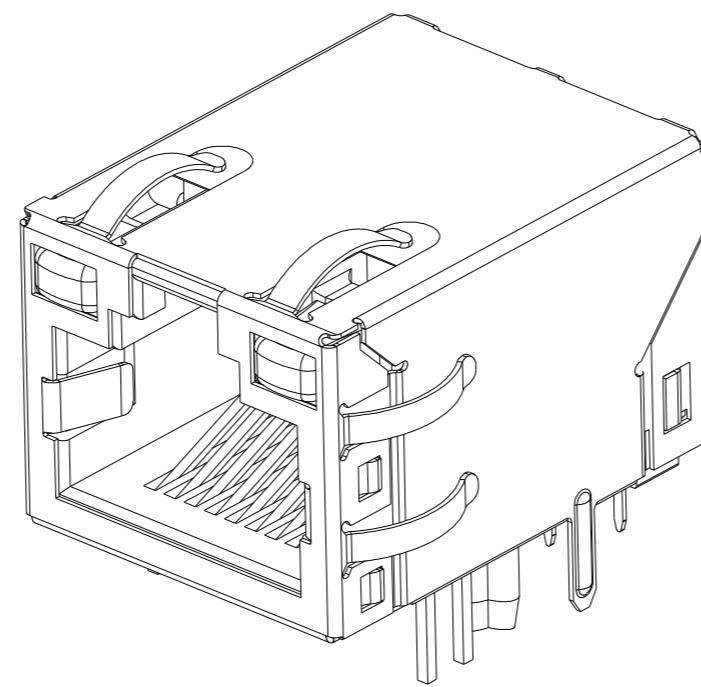
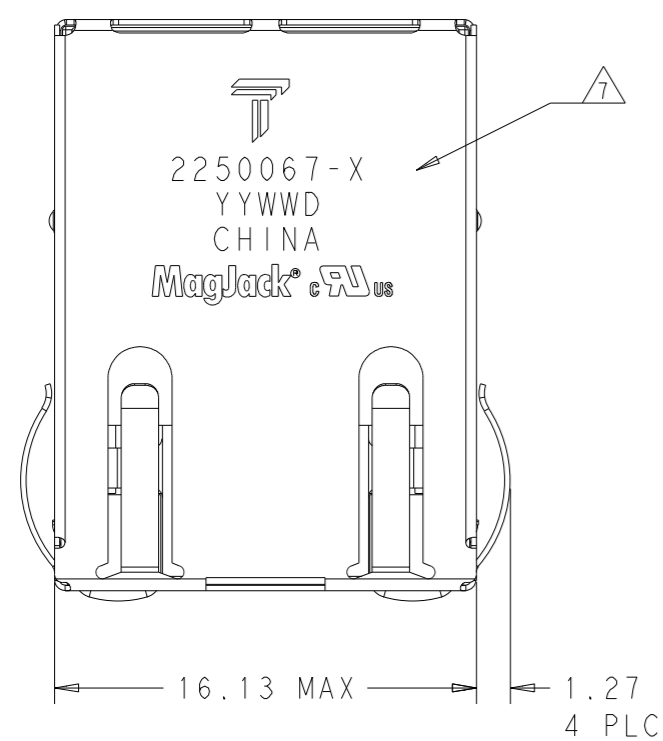

1. MATERIALS

- HOUSING: THERMOPLASTIC, FLAMMABILITY RATING UL 94V-0.
- SHIELD: BRASS 0.20mm THICK, PREPLATED WITH 0.76um MIN SEMI-BRIGHT NICKEL. SOLDER TABS POST DIPPED WITH 2.54um MIN SAC SOLDER.
- CONTACTS: PHOSPHOR BRONZE 0.46mm X 0.30mm, PHOSPHOR BRONZE, 1.27um MIN NICKEL UNDERPLATE, WITH 1.27um MIN GOLD PLATING AT MATING INTERFACE AND 2.54um MIN MATTE TIN ON SOLDER TAILS, OR 1.27um MIN NICKEL UNDERPLATE, WITH 0.05um GOLD PLATING OVER 0.76um MIN PALLADIUM NICKEL PLATING AT MATING INTERFACE AND 2.54um MIN MATTE TIN ON SOLDER TAILS.
- SOLDER TAILS: 0.25mm THICK, PHOSPHOR BRONZE, 1.27um MIN OVERALL NICKEL UNDERPLATE, 3um TIN PLATE
- LIGHT EMITTING DIODE (LED): DIFFUSED EPOXY LENS, 0.5mm X 0.5mm CARBON STEEL WIREFRAME LEADS PREPLATED WITH 2.03um MIN. SILVER PLATE OVER 1.02um MIN. NICKEL OVER 1.02um MIN. COPPER UNDERPLATE; LEADS POST-PLATED WITH 3.05um MIN. MATTE TIN AND/OR SAC SOLDER DIP OR PURE TIN SOLDER DIP

△ RJ45 JACK CAVITY CONFORMS TO FCC RULES AND REGULATIONS PART 68 SUB PART F.

△ 3. MAGNETICS

- APPLICATION: 10/100 BASE-T
- IMPEDANCE: 100 OHMS
- TURNS RATIO (CHIP:CABLE): TX = 1:1, RX = 1:1
- OPEN CIRCUIT INDUCTANCE (OCL): 350uH MIN @100kHz, 0.1VRMS, 8mADC BIAS FROM 0°C TO +70°C, TX AND RX
- PERFORMANCE @ 25°C:
- INSERTION LOSS (IL): 1.1dB MAX FROM 0.5MHz TO 100MHz
- RETURN LOSS (RL): 18dB MIN FROM 0.5MHz TO 30MHz
- 18-20LOG(f/30)dB MIN FROM 30.1MHz TO 60MHz
- 12dB MIN FROM 60.1MHz TO 80MHz
- CROSSTALK ATTENUATION: 35dB MIN FROM 0.5MHz TO 40MHz
- 33-20LOG(f/50)dB MIN FROM 40.1MHz TO 100MHz
- COMMON MODE REJECTION RATIO (CMRR): 30dB MIN FROM 0.5MHz TO 100MHz
- ISOLATION VOLTAGE: 2250VDC FOR 60 SECONDS WITH A RISE TIME OF 500 V/SEC

4. OPERATING TEMPERATURE: FROM 0°C TO +70°C.

△ INDICATED MAGNETIC CONNECTIONS ARE SYMMETRICAL TO SUPPORT AUTO-MDI/MDIX.

△ THE 250 OHM LED RESISTORS ARE OPTIONAL, PLEASE SEE CHART FOR PRESENCE OR ABSENCE OF RESISTORS.  
 IF LEADS WITHOUT 250 OHM RESISTORS. LEADS ARE DRIVEN WITH CONSTANT CURRENT AT APPROX 20mA  
 LED COLOR: DOMINATE WAVELENGTH (λD): GREEN 568 nm TYP. AT IF = 20mA  
 FORWARD VOLTAGE (VF): GREEN 2.2V TYP. at IF = 20mA  
 DOMINATE WAVELENGTH (λD): YELLOW 588 nm TYP. AT IF = 20mA  
 FORWARD VOLTAGE (VF): YELLOW 2.1V TYP. at IF = 20mA  
 IF LEADS WITH BUILT-IN 250 OHM RESISTORS. LEADS ARE DRIVEN WITH 5V VOLTAGE AND THE MAX OPERATING CURRENT IS 20mA  
 LED COLOR: DOMINATE WAVELENGTH (λD): GREEN 568 nm TYP. @ VF=5V  
 FORWARD CURRENT (IF): GREEN 12mA TYP @ VF = 5V  
 DOMINATE WAVELENGTH (λD): YELLOW 588 nm TYP. @ VF=5V  
 FORWARD CURRENT (IF): YELLOW 13mA TYP @ VF = 5V

△ TRP CONNECTOR LOGO, PART NUMBER, DATE CODE, COUNTRY OF ORIGIN AND AGENCY APPROVAL MARKING IN APPROXIMATE LOCATION SHOWN. DATE CODE: YYWWDD WHERE YY IS YEAR, WW IS WORK WEEK, D IS DAY OF WEEK, WITH SUNDAY=1.

8. PART SHOULD BE RECOMMENDED FOR WAVE SOLDERING PROCESS. PREHEAT TEMPERATURE IS 120°C TO 160°C, 120 SECONDS TO 180 SECONDS, PEAK WAVE SOLDERING TEMPERATURE IS 260°C MAX, 10 SECONDS MAX.

NO	YES	GREEN	-	YES	YELLOW	YES	2250067-8
YES	YES	GREEN	YELLOW	NO	GREEN	NO	2250067-7
YES	NO	GREEN	-	YES	YELLOW	YES	2250067-6
YES	YES	GREEN	-	YES	GREEN	YES	2250067-5
YES	YES	GREEN	-	NO	YELLOW	NO	2250067-4
YES	YES	GREEN	-	NO	GREEN	NO	2250067-3
YES	YES	YELLOW	-	YES	GREEN	YES	2250067-2
YES	YES	GREEN	-	YES	YELLOW	YES	2250067-1
2kV CAPACITOR	EMI FINGERS ①	9	LED 1	10	LED 2	11	PART NUMBER

THIS DRAWING IS A CONTROLLED DOCUMENT.		OWN ROY LIU	17DEC2013	 <b>trp</b> CONNECTOR a bel group DONGGUAN CHINA													
DIMENSIONS: mm		CHK TOWER YU/ FRANK LIU	17DEC2013														
TOLERANCES UNLESS OTHERWISE SPECIFIED:		APP'D TONY YUAN	17DEC2013														
<table border="1"> <tr><td>0 PLC</td><td>±0.25</td></tr> <tr><td>1 PLC</td><td>±0.25</td></tr> <tr><td>2 PLC</td><td>±0.25</td></tr> <tr><td>3 PLC</td><td>±0.25</td></tr> <tr><td>4 PLC</td><td>±</td></tr> <tr><td>ANGLES</td><td>±</td></tr> <tr><td>APPLICATION SPEC</td><td>±</td></tr> </table>		0 PLC	±0.25		1 PLC	±0.25	2 PLC	±0.25	3 PLC	±0.25	4 PLC	±	ANGLES	±	APPLICATION SPEC	±	MODEL NAME MAGJACK
0 PLC	±0.25																
1 PLC	±0.25																
2 PLC	±0.25																
3 PLC	±0.25																
4 PLC	±																
ANGLES	±																
APPLICATION SPEC	±																
PRODUCT SPEC	APPLICATION SPEC	SIZE A 1	CAGE CODE C=2250067	RESTRICTED TO -													
CUSTOMER DRAWING			SCALE 4:1	SHEET 1 OF 3													
			REV 2														

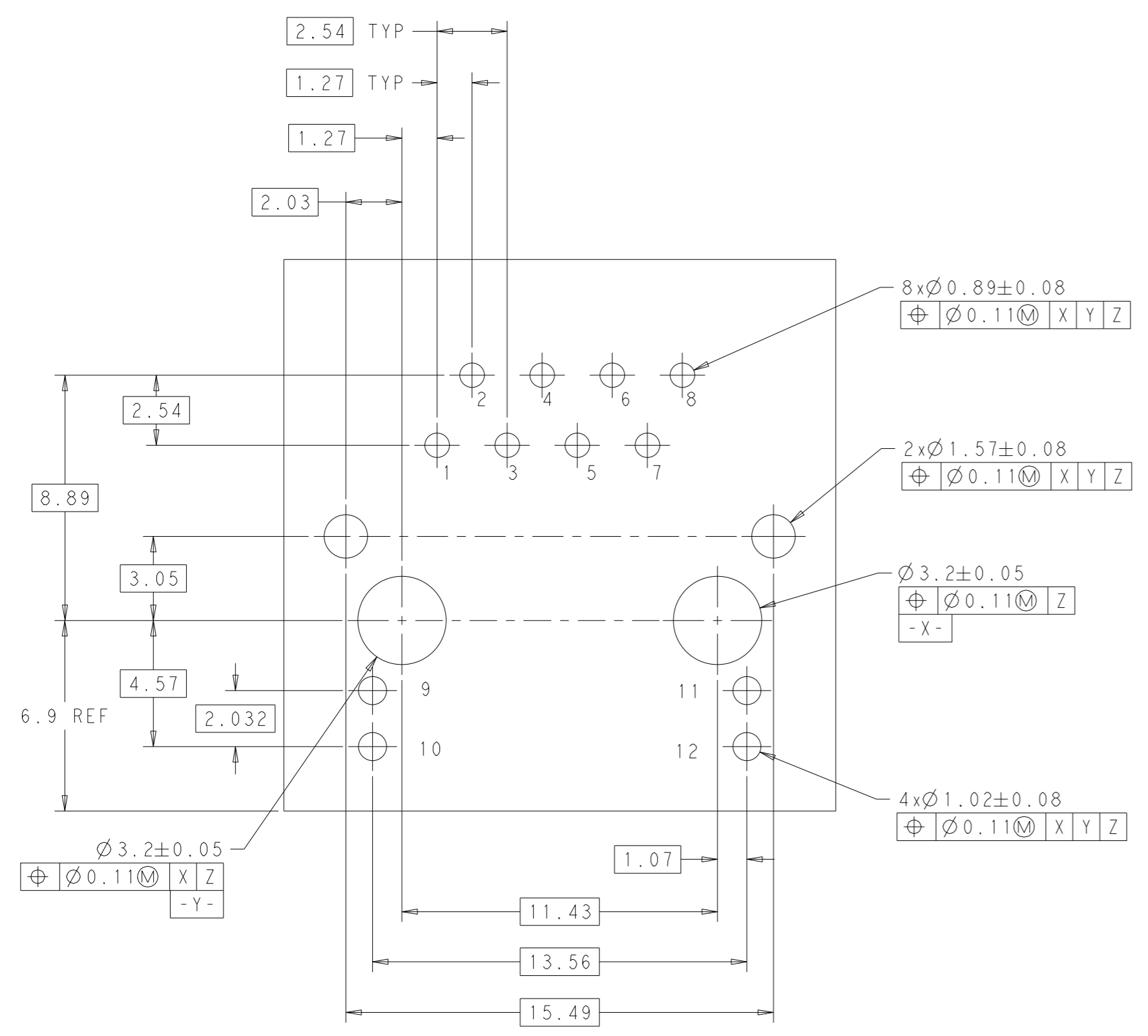

SUGGESTED PCB LAYOUT

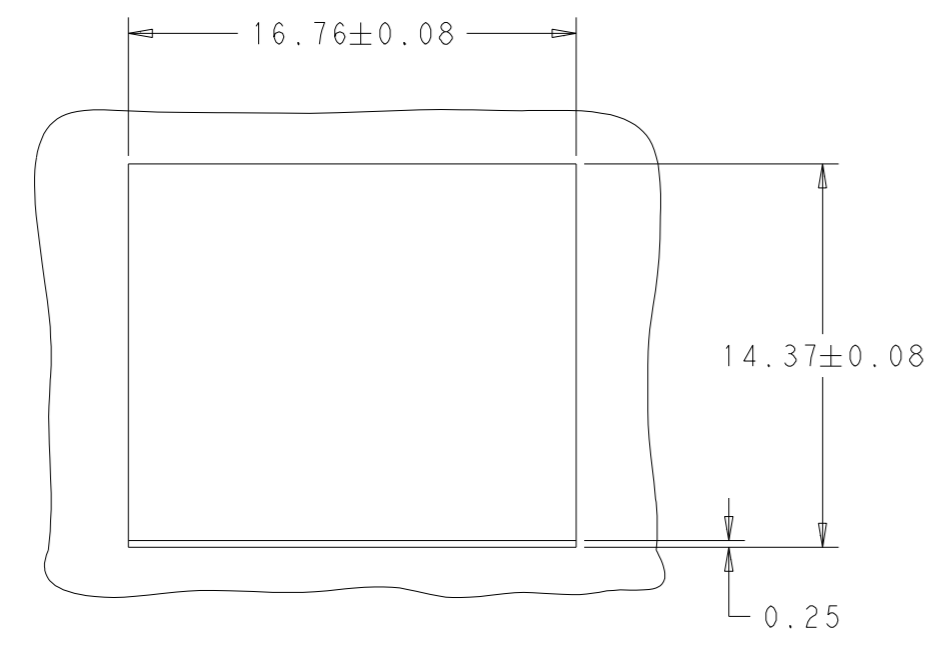

SUGGESTED PANEL CUTOUT

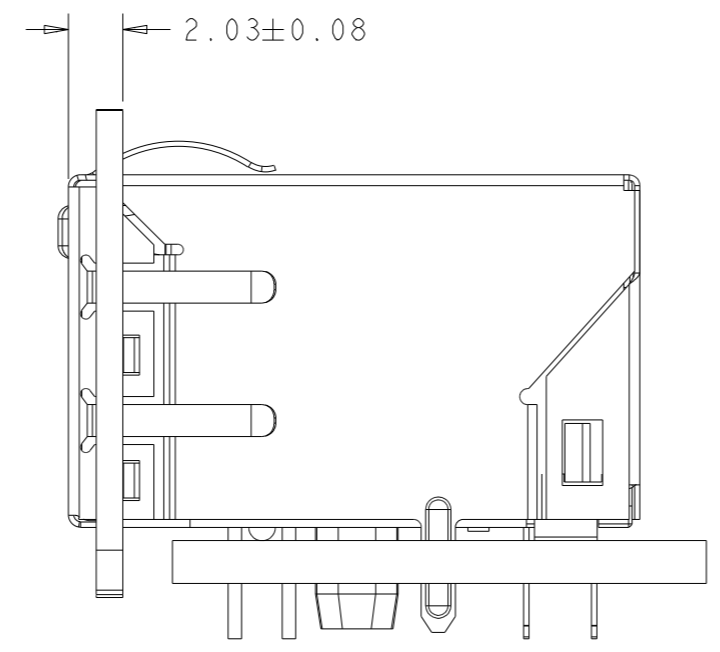

# 726 10/100 CIRCUIT

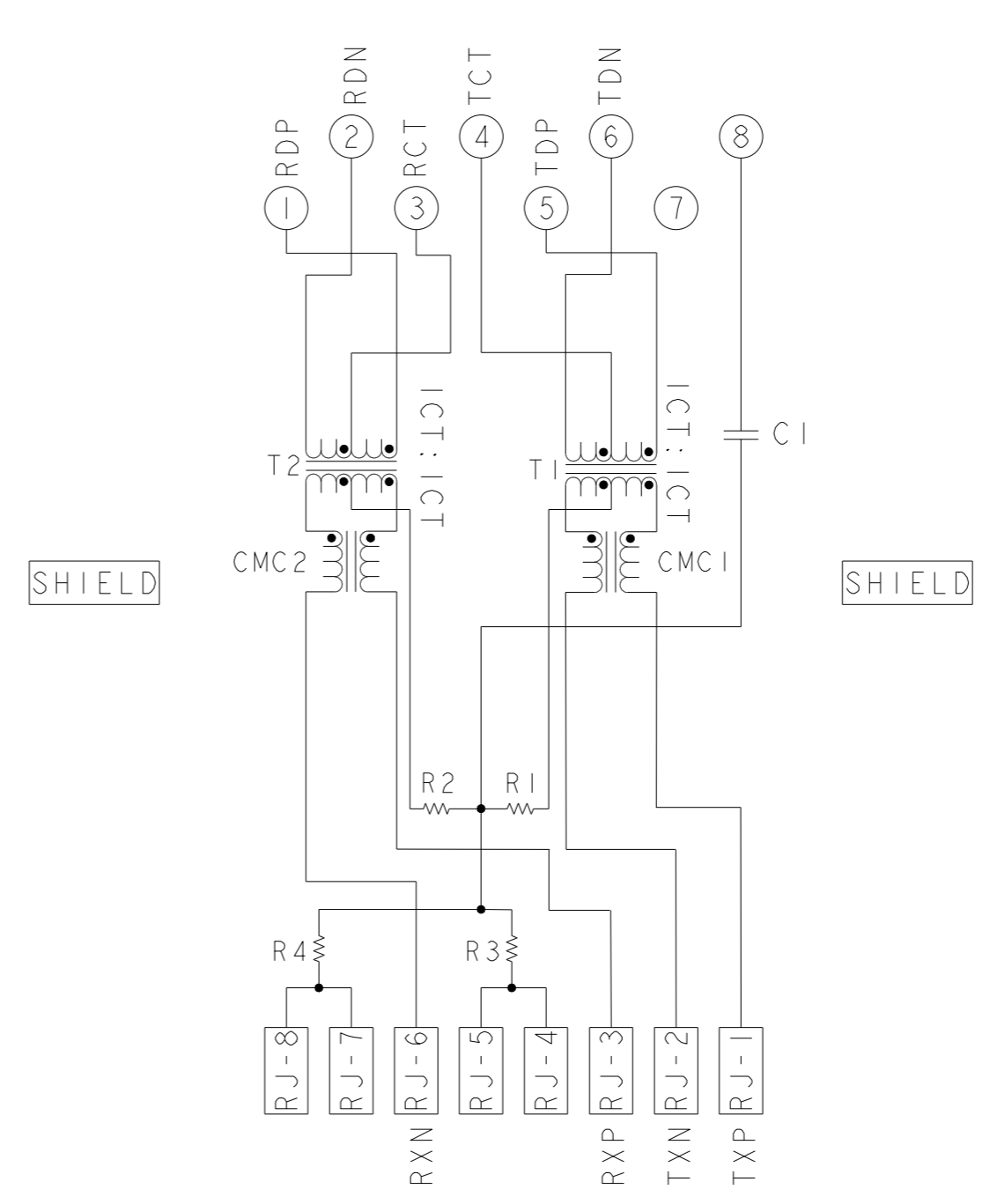

C1=1000pF, 2kV CAPACITOR  
 R1-R4 = 75 Ohms, 1/16 W RESISTORS

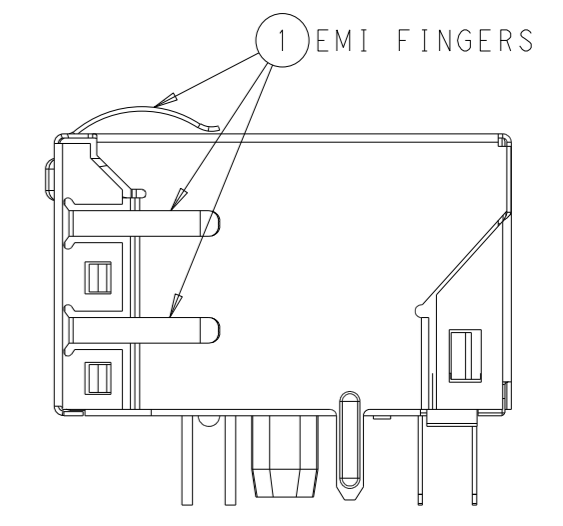

FOR 2250067-1, 2250067-2  
 2250067-3, 2250067-4  
 2250067-5, 2250067-7

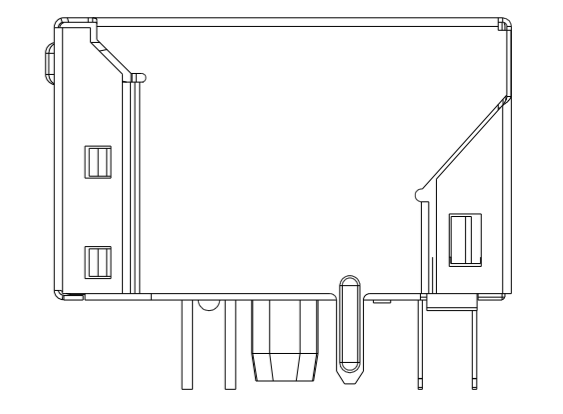

FOR 2250067-6

THIS DRAWING IS A CONTROLLED DOCUMENT.		DRN ROY LIU	17DEC2013	 <b>trp</b> CONNECTOR a bel group DONGGUAN CHINA
DIMENSIONS: mm		CHK TOWER YU / FRANK LIU	17DEC2013	
TOLERANCES UNLESS OTHERWISE SPECIFIED:		APP'D TONY YUAN	17DEC2013	
0 PLC ±0.25 1 PLC ±0.25 2 PLC ±0.25 3 PLC ±0.25 4 PLC ± ANGLES ±		MODEL NAME MAGJACK	DESC IX1 726 10/100 TAB UP W/ LED	
PRODUCT SPEC	APPLICATION SPEC	SIZE A1	CAGE CODE C=2250067	RESTRICTED TO -
CUSTOMER DRAWING		SCALE 4:1	SHEET 2 OF 3	REV 2

C_2250067					STOCK DISPOSITION			
REVISION HISTORY					A: CONTINUE AS IS		D: USE OLD FIRST	
					B: REWORK		E: PARTS TO CONFORM	
					C: SCRAP		F: OTHER	
DATE	REV	CHANGES	REASON	APPROVAL	INVENTORY (A,B,C,D,E,F)	WORK IN PROCESS (A,B,C,F)	SUPPLIER ORDERS (A,E,F)	OPEN CUST ORDERS (A,E,F)
17DEC2013	1	-	INITIAL RELEASE	TONY YUAN	-	-	-	-
04JAN2015	2	EC-1411035 COMPANY LOGO CHANGE	MARKET REQUEST	TONY YUAN	-	-	-	-

THIS DRAWING IS A CONTROLLED DOCUMENT.

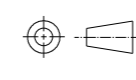
DIMENSIONS:	TOLERANCES UNLESS OTHERWISE SPECIFIED:	DWN ROY LIU 17DEC2013	 <b>trp</b> CONNECTOR a bel group	DONGGUAN CHINA	
mm	0 PLC ±0.25 1 PLC ±0.25 2 PLC ±0.25 3 PLC ±0.25 4 PLC ±	CHK TOWER YU/ FRANK LIU 17DEC2013		DESC IX1 726 10/100 TAB UP W/ LED	
	ANGLES ±	APPRO TONY YUAN 17DEC2013		MODEL NAME MAGJACK	RESTRICTED TO
PRODUCT SPEC	APPLICATION SPEC		SINGLE NON-POE	SIZE A1	
			CUSTOMER DRAWING	SCALE 4:1 SHEET 3 OF 3 REV 2	

## X-ON Electronics

Largest Supplier of Electrical and Electronic Components

*Click to view similar products for [Modular Connectors / Ethernet Connectors](#) category:*

*Click to view products by [Bel Fuse](#) manufacturer:*

Other Similar products are found below :

[8949-H88/06BLKA/SN](#) [74441-0010/BKN](#) [PHP-6P6C-5](#) [GAX-3-66](#) [GAX-8-62](#) [GDCX-PN-66](#) [GLX-A-44](#) [GLX-N-1010M-BLK](#) [GMX-SMT4-N-88](#) [GSGX-N-2-88](#) [GSGX-N-4-88](#) [GSX-NS2-88-3.05](#) [GSX-NS-88-3.68](#) [PT-108A-8C-UL](#) [PTS-J531-8CS-50UL](#) [A-2014-0-4](#) [GWLX-S9-88-YG](#) [DC-1021-8-WH-6](#) [1300530003](#) [1324640-4](#) [RJ11FTVC2G](#) [RJ11FTVC2N](#) [RJFTVX2SA1G](#) [132764-001](#) [1413235](#) [MPS88RX-5000](#) [E5288-S000K3-L](#) [155302-001](#) [AX101050](#) [AX101063](#) [AX101065](#) [AX101072](#) [AX101307](#) [AX101315](#) [AX101318](#) [AX102271](#) [AX102288](#) [AX102651](#) [AX102660](#) [AX104024](#) [J0012D21NL](#) [J0026D01ENL](#) [PC4D0018P](#) [8949-B88/6](#) [2-6609208-5](#) [303066VFL](#) [303068V](#) [303088LFLSA](#) [303088SBL](#) [30-8603](#)