

THIS DRAWING AND THE SUBJECT MATTER SHOWN THEREON ARE CONFIDENTIAL AND THE PROPERTY OF BEL/STEWART/TRP CONNECTOR AND SHALL NOT BE REPRODUCED, COPIED, OR USED IN ANY MANNER WITHOUT THE WRITTEN CONSENT OF TRP CONNECTOR.

PRODUCT MAY BE PROTECTED BY ONE OR MORE OF THE FOLLOWING US PATENTS:
 5736910 5939955 6425781 6428361 6554638 6840817 7123117
 7429195 7717749 7808751 6217391 6149050 7924130

REVISIONS				
P	LYR	DESCRIPTION	DATE	APVD
G		EC-1411035 COMPANY LOGO CHANGE	06JAN2015	DZ TL

MECHANICAL:

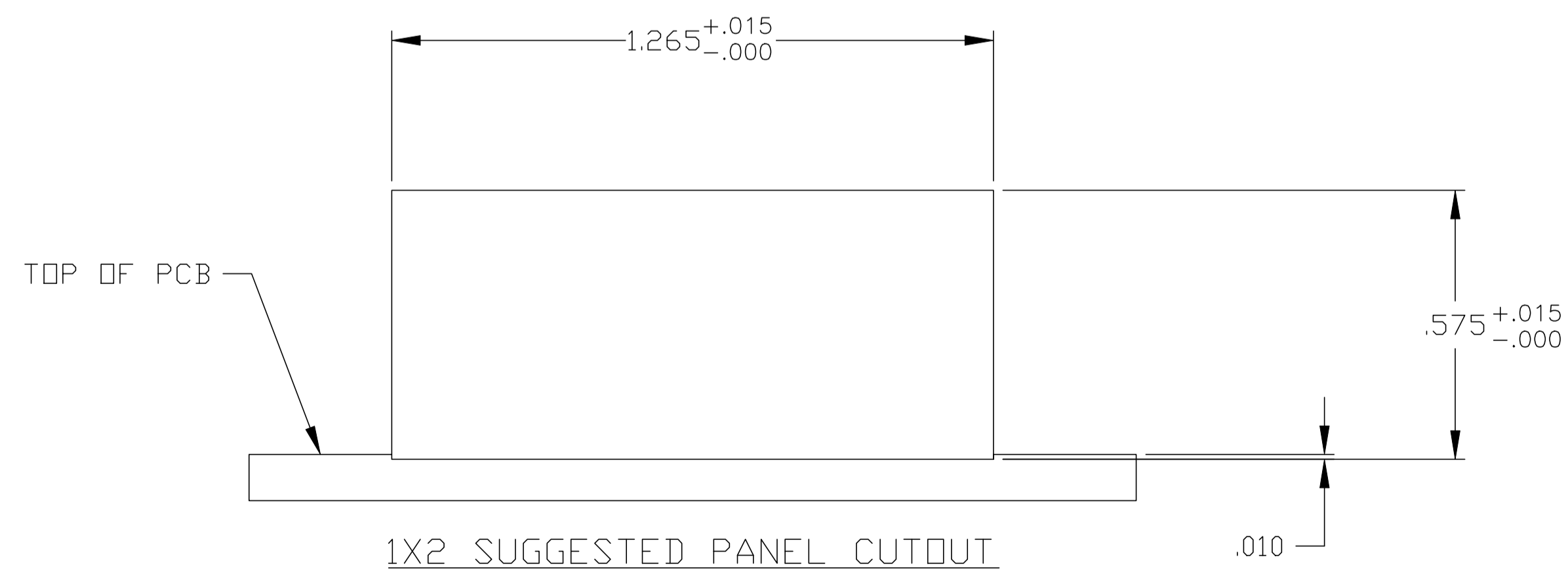
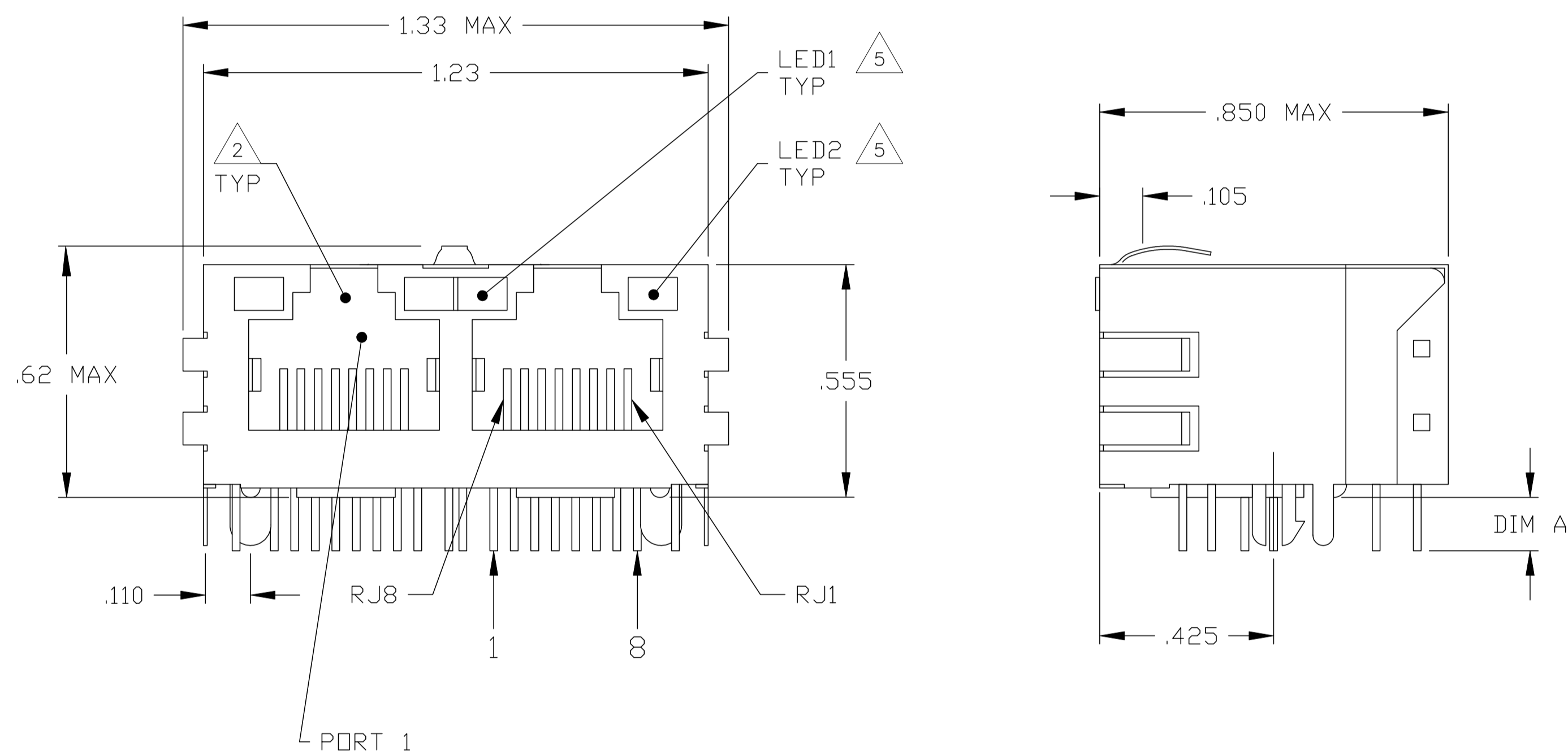
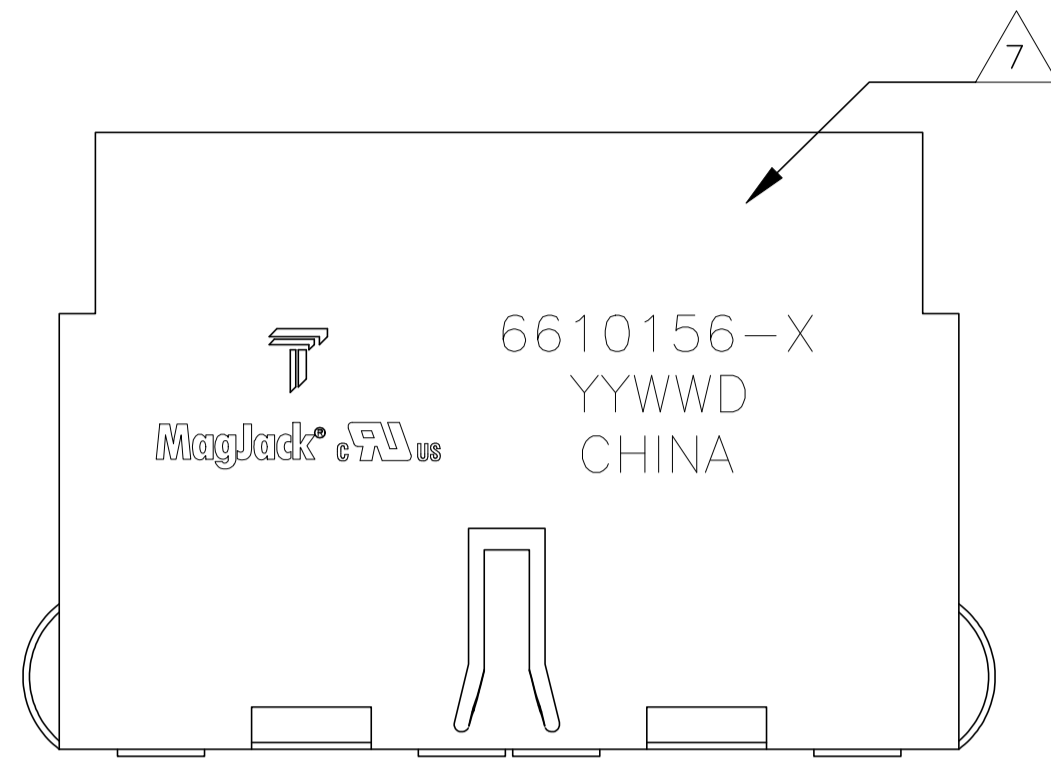

- 1. MATERIALS:
 -HOUSING - THERMOPLASTIC PET POLYESTER FLAMMABILITY RATING UL 94V-0
 -SHIELD - 0.010" THICK, C26800 BRASS PREPLATED WITH 30μ INCH MIN SEMI-BRIGHT NICKEL. SOLDER TABS POST DIPPED WITH 100μ INCH MIN SAC SOLDER.
 -MOD JACK CONTACTS - 0.0157" X 0.018" PHOSPHOR BRONZE, 50μ INCH MIN OVERALL NICKEL UNDERPLATE WITH SELECT 50μ INCH MIN HARD GOLD FINISH PLATE. SOLDER TAILS WITH 100μ INCH MIN MATTE TIN AND/OR SAC SOLDER DIP.
 -LIGHT EMITTING DIODE(LED) - DIFFUSED EPOXY LENS, 0.020" X 0.020" CARBON STEEL WIREFRAME LEADS PRE-PLATED WITH 80μ INCH SILVER OVER 40μ INCH NICKEL UNDERPLATE OVER 40μ INCH COPPER UNDERPLATE. POST-PLATED WITH 100μ INCH MIN MATTE TIN AND/OR SAC SOLDER DIP OR PURE TIN SOLDER DIP.
- 2. RJ45 JACK CAVITY CONFORMS TO FCC RULES AND REGULATIONS PART 68, SUB PART F.
- 3. MAGNETICS
 -IMPEDANCE: 100 OHMS
 -TURNS RATIO (CHIP: CABLE): TX = 1:1, RX = 1:1
 -OPEN CIRCUIT INDUCTANCE (OCL): 350μ H MIN @100kHz, 0.1VRMS, 8mADC BIAS FROM 0°C TO 70°C, TX AND RX
 -PERFORMANCE @ 25°C:
 INSERTION LOSS (IL): 1.1dB MAX FROM 0.5MHz TO 100MHz
 RETURN LOSS (RL): 18dB MIN FROM 0.5MHz TO 30MHz
 18-20LOG(f/30)dB MIN FROM 30.1MHz TO 60MHz
 12dB MIN FROM 60.1MHz TO 80MHz
 CROSSTALK ATTENUATION: 35dB MIN FROM 0.5MHz TO 40MHz
 33-20*LOG(f/50)dB MIN FROM 40.1MHz TO 100MHz
 COMMON MODE REJECTION RATIO (CMRR): 30dB MIN FROM 0.5MHz TO 100MHz
 -ISOLATION VOLTAGE: 2250VDC (MAX) FOR 60 SECONDS WITH A RISE TIME OF 500V/SEC AND WITH ALL PORTS CONNECTED.
- 4. OPERATING TEMPERATURE: FROM 0°C TO +70°C.
- 5. THE LED WITH 250 OHM RESISTORS, LED IS DRIVEN WITH 5V VOLTAGE AND THE MAX OPERATING CURRENT IS 20mA. LED COLOR :
 DOMINANT WAVELENGTH (LD): GREEN 568 nm TYP. At VF=5V
 FORWARD CURRENT (IF): GREEN 12 mA TYP. at VF=5V
 DOMINANT WAVELENGTH (LD): YELLOW 588 nm TYP. At VF=5V
 FORWARD CURRENT (IF): YELLOW 13 mA TYP. at VF=5V
- 6. INDICATED CONNECTIONS ARE FOR A HUB CONFIGURATION. THE MAGNETICS ARE SYMMETRICAL AND SUPPORT AUTO-MDIX.
- 7. TRP CONNECTOR LOGO, PART NUMBER, DATE CODE, COUNTRY OF ORIGIN AND AGENCY APPROVAL MARKING IN APPROXIMATE LOCATION AS SHOWN.
- 8. THE PART IS RECOMMENDED FOR WAVE SOLDERING PROCES, PEAK WAVE SOLDERING TEMPERATURE IS 265°C MAX, 10 SECONDS MAX.

.090±.010	GREEN	YELLOW	2-6610156-8
.145±.010	GREEN	YELLOW	5-6610156-8
DIM A	LED1 5	LED2 5	PART NUMBER

THIS DRAWING IS A CONTROLLED DOCUMENT.		DWN G. ATTADIA - DOCK5 15MAR2005 CHK D. FAROLE 15MAR2005		DONGGUAN CHINA																														
DIMENSIONS: INCHES		APVD D. FAROLE 15MAR2005																																
<table border="1"> <tr><td>0 PLC</td><td>±</td><td>-</td></tr> <tr><td>1 PLC</td><td>±</td><td>-</td></tr> <tr><td>2 PLC</td><td>±</td><td>.010</td></tr> <tr><td>3 PLC</td><td>±</td><td>.005</td></tr> <tr><td>4 PLC</td><td>±</td><td>-</td></tr> <tr><td>ANGLES</td><td>±</td><td>-</td></tr> </table>		0 PLC	±	-	1 PLC	±	-	2 PLC	±	.010	3 PLC	±	.005	4 PLC	±	-	ANGLES	±	-	<table border="1"> <tr><td>MODEL NAME</td><td>MAGJACK GANG</td></tr> <tr><td>DESC</td><td>1X2 766 10/100 TAB UP W/ LED</td></tr> <tr><td>SIZE</td><td>A1</td></tr> <tr><td>CAGE CODE</td><td>NON-POE</td></tr> <tr><td>DRAWING NO</td><td>C-6610156</td></tr> <tr><td>RESTRICTED TO</td><td>-</td></tr> </table>		MODEL NAME	MAGJACK GANG	DESC	1X2 766 10/100 TAB UP W/ LED	SIZE	A1	CAGE CODE	NON-POE	DRAWING NO	C-6610156	RESTRICTED TO	-	CUSTOMER DRAWING SCALE NTS SHEET 1 OF 2 REV G
0 PLC	±	-																																
1 PLC	±	-																																
2 PLC	±	.010																																
3 PLC	±	.005																																
4 PLC	±	-																																
ANGLES	±	-																																
MODEL NAME	MAGJACK GANG																																	
DESC	1X2 766 10/100 TAB UP W/ LED																																	
SIZE	A1																																	
CAGE CODE	NON-POE																																	
DRAWING NO	C-6610156																																	
RESTRICTED TO	-																																	
PRODUCT SPEC 108-2100		APPLICATION SPEC -																																

766 SERIES MAGNETIC CIRCUIT

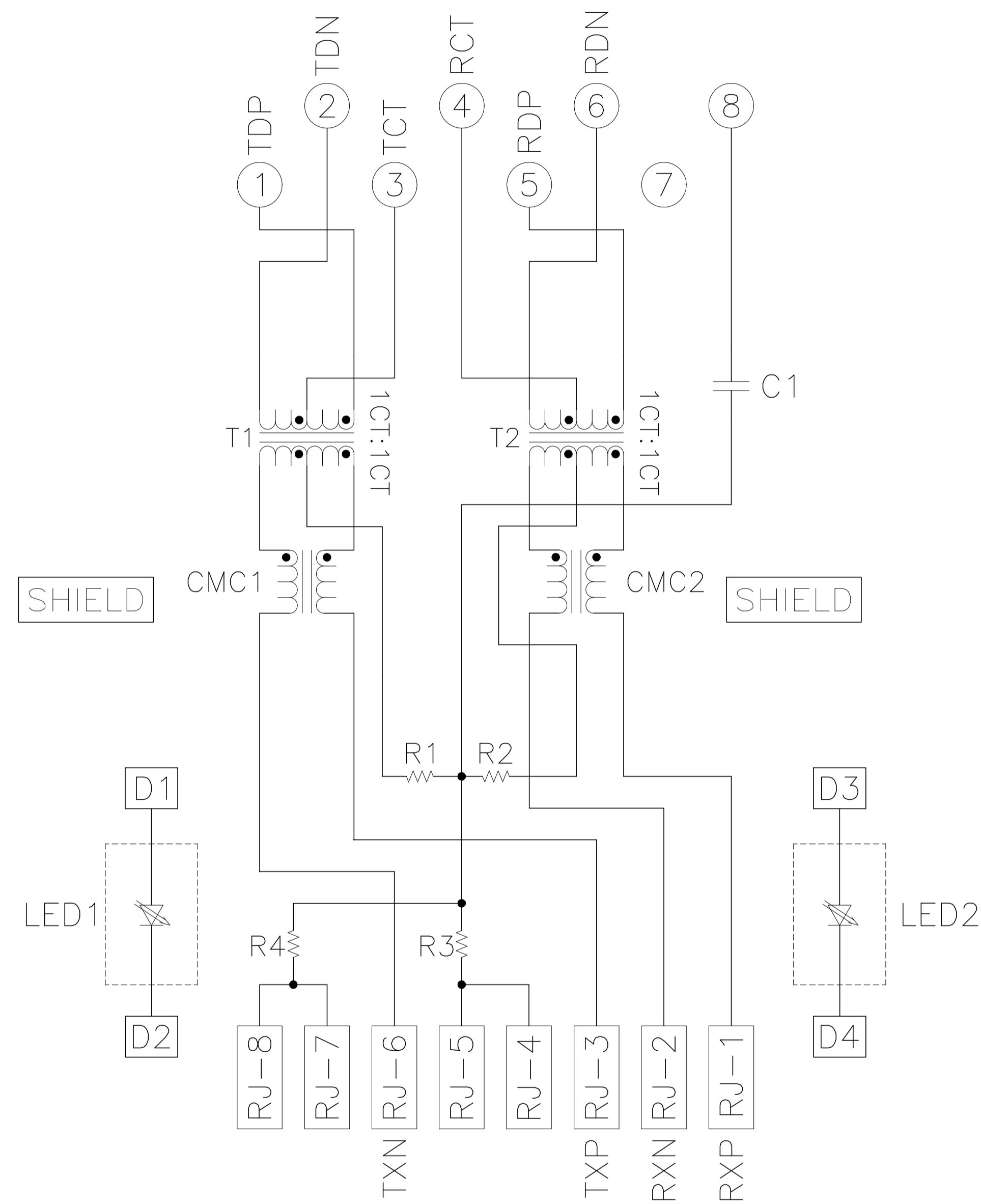

C1 = 1000 pF, 2KV CAPACITOR

R1-R4 = 75 OHMS, 1/16W RESISTORS

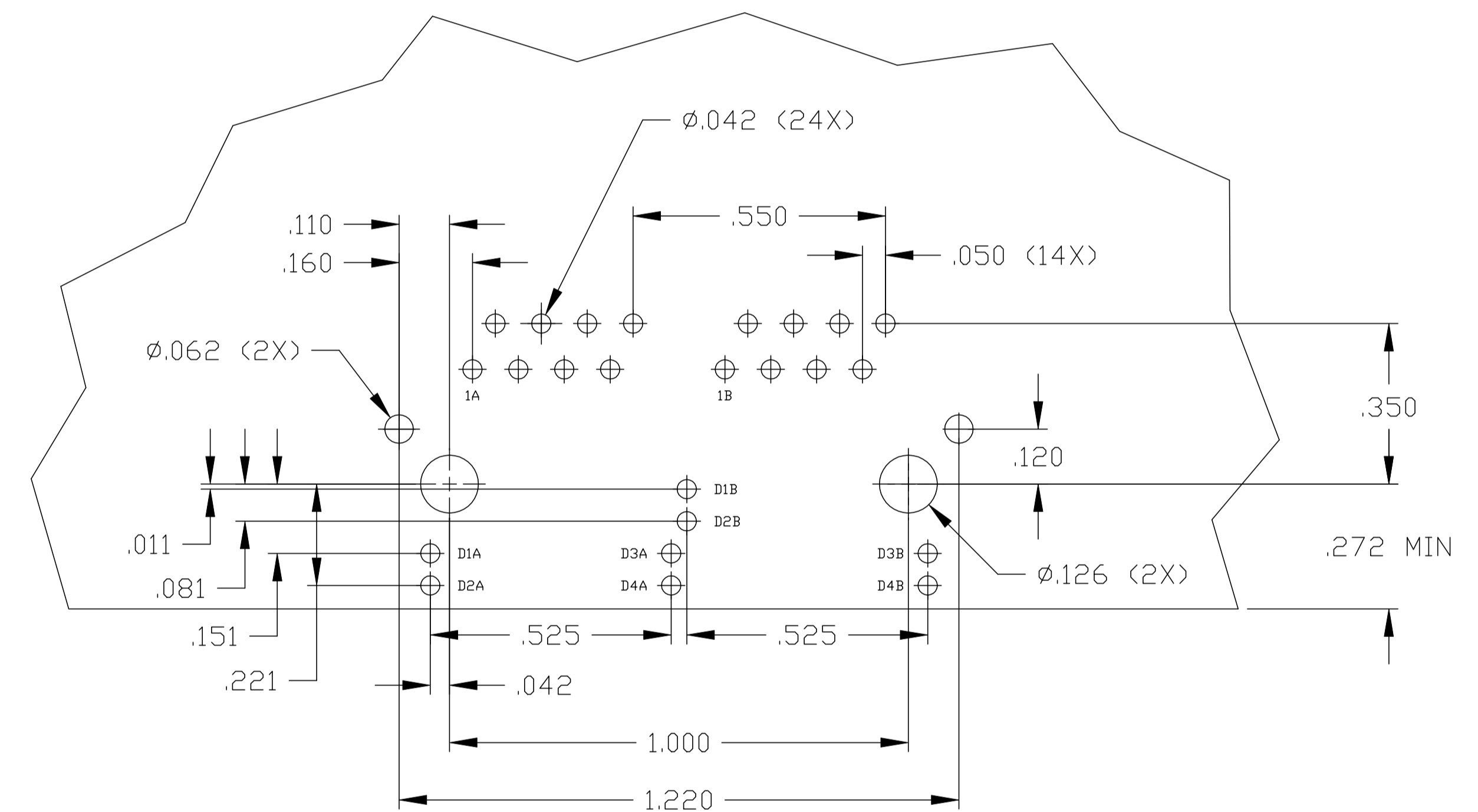
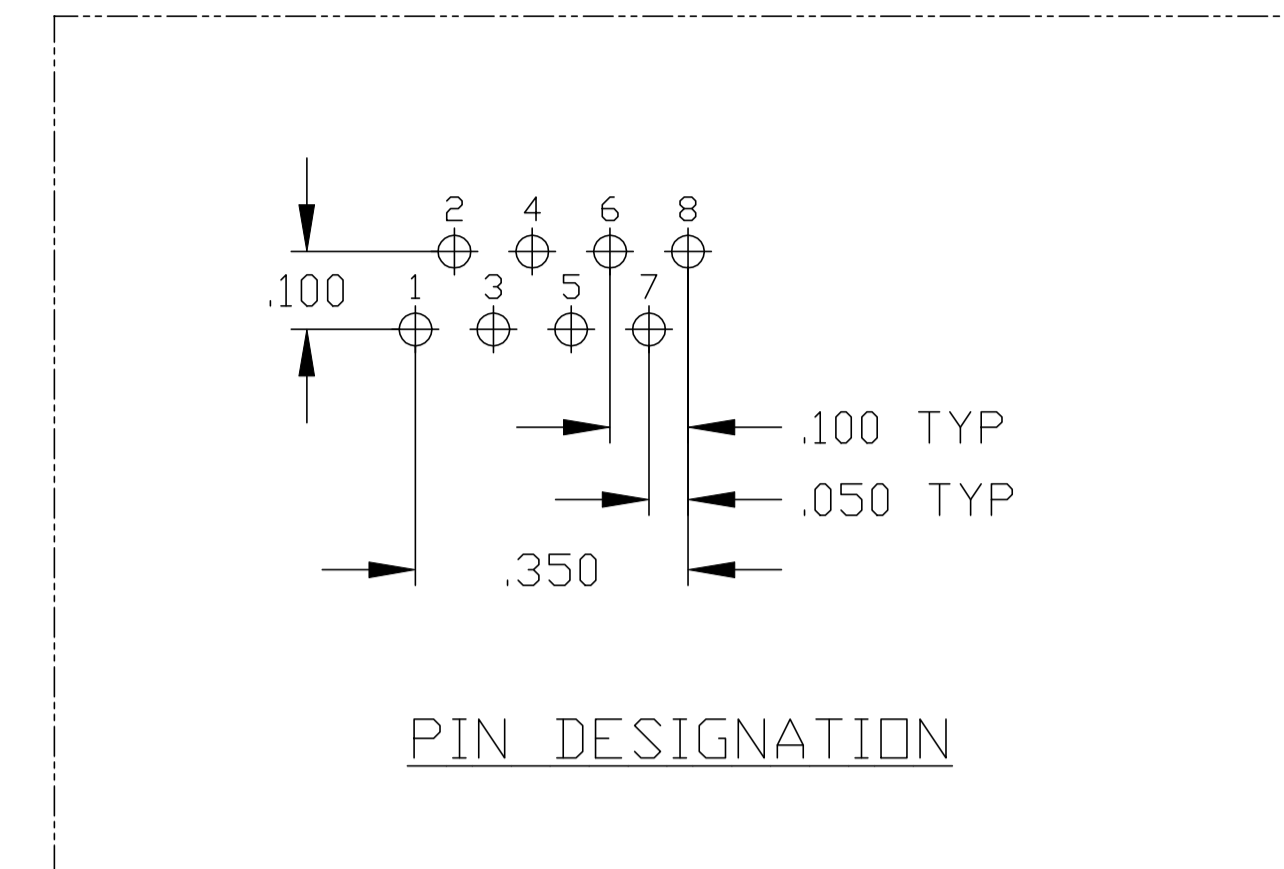

SUGGESTED PCB LAYOUT (Component Side)

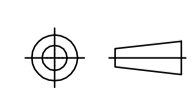
THIS DRAWING IS A CONTROLLED DOCUMENT.		DWN: G. ATTADIA - DOCK5 15MAR2005 CHK: D. FAROLE 15MAR2005 APVD: D. FAROLE 15MAR2005		 DONGGUAN CHINA	
DIMENSIONS: INCHES 		TOLERANCES UNLESS OTHERWISE SPECIFIED: 0 PLC ± - 1 PLC ± - 2 PLC ± .010 3 PLC ± .005 4 PLC ± - ANGLES ± -		MODEL NAME: MAGJACK GANG NON-POE	
PRODUCT SPEC: 108-2100 APPLICATION SPEC: -		DESC: 1X2 766 10/100 TAB UP W/ LED SIZE: A1 CAGE CODE: C-6610156 DRAWING NO: - RESTRICTED TO: -		CUSTOMER DRAWING SCALE: NTS SHEET: 2 OF 2 REV: G	

X-ON Electronics

Largest Supplier of Electrical and Electronic Components

Click to view similar products for [Modular Connectors / Ethernet Connectors](#) category:

Click to view products by [Bel Fuse](#) manufacturer:

Other Similar products are found below :

[8949-H88/06BLKA/SN](#) [74441-0010/BKN](#) [MP1010RX-1000](#) [MP44RX-1000](#) [PHJ-4P4C-1-V-4](#) [PHP-6P6C-5](#) [GAX-3-66](#) [GAX-8-62](#) [GDCX-PA-66-50](#) [GDCX-PN-64](#) [GDCX-PN-66](#) [GDCX-PN-66-50](#) [GDLX-A-66](#) [GDLX-N-66](#) [GDLX-S-66](#) [GDLX-S-88K](#) [GDLX-SMT-S-88](#) [GDTX-S-88-50](#) [GDX-PA-1010](#) [GLX-N-1010M-BLK](#) [GLX-S-88M-BLK](#) [GMX-N-1010](#) [GMX-S-1010](#) [GMX-S-66](#) [GMX-SMT4-N-88](#) [GPX-2-64](#) [GSGX-N-2-88](#) [GSGX-N-4-88](#) [GSX-NS2-88-3.05](#) [GSX-NS2-88-3.05-50](#) [GSX-NS-88-3.05-50](#) [PT-108A-8C-UL](#) [PT-J951-8C](#) [PTS-J531-8CS-50UL](#) [1-1775629-2](#) [A-2014-0-4](#) [GWLX-S-88-GR](#) [GWLX-S9-88-YG](#) [DC-1021-8-WH-6](#) [1300530003](#) [1324640-4](#) [RJ11FTVC2G](#) [RJ11FTVC2N](#) [RJFTVX2SA1G](#) [132764-001](#) [1413235](#) [MP88X-1000](#) [MPS88RX-5000](#) [E5288-S000K3-L](#) [E5908-15A242-L](#)