

DRAWING REVISIONS

REV	DOCUMENT	APP	DATE
B	CO 4256	NC	3/31/20

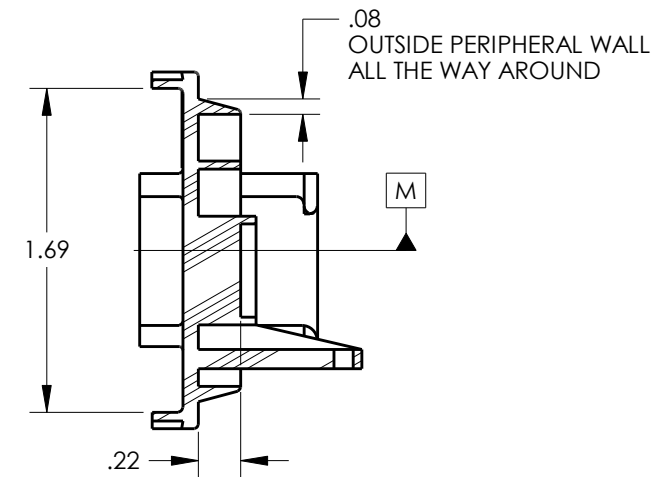

SECTION B-B

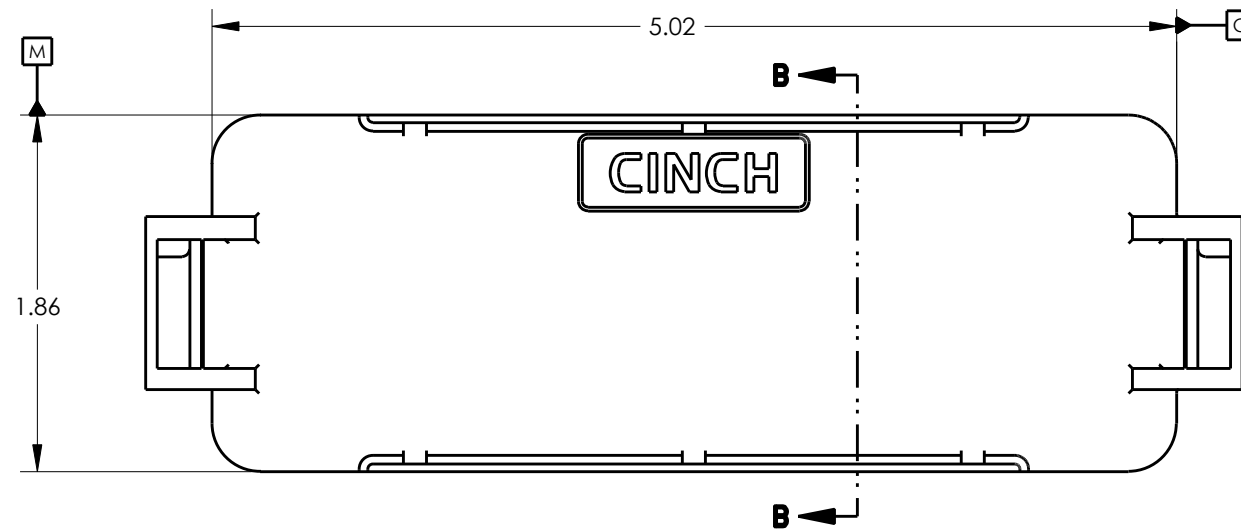
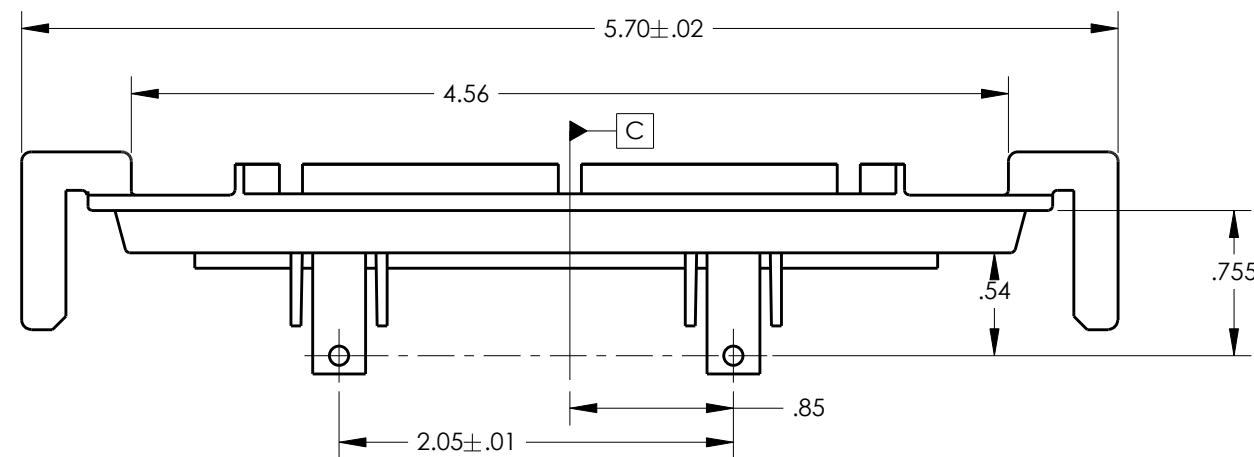

NOTES:

1. ALL DIMENSIONS ARE IN INCHES; DIMENSION INSIDE [.XX] ARE IN MM, AS REF. ONLY.
2. MATERIAL: 30 % GLASS FILLED POLYMER, COLOR: BLACK
3. ALL HEADERS ARE REFLOW OR WAVE SOLDERING PROCESS, ROHS COMPLIANT.
4. THERMALLY CONDUCTIVE ADHESIVE PASTE SOLD SEPARATELY: RECOMMENDED IS LOCTITE 383.
5. MOSFET SPRING PLATES ARE SOLD SEPARATLY (FOR INSTALLATION REFER TO ENCLOSURE ASSEMBLY INSTRUCTIONS) SPRING LABELED AS "L" IS CINCH P/N: 581 00 00 020 AND SPRING LABELED AS "R" IS CINCH P/N: 581 00 00 021. (IT IS RECOMMENDED THAT THE FOUR SLOTS BE PROTECTED DURING CONFORMAL COATING)
6. STANDARD PACKAGE SIZE: 72 PARTS/CARTON BOX.

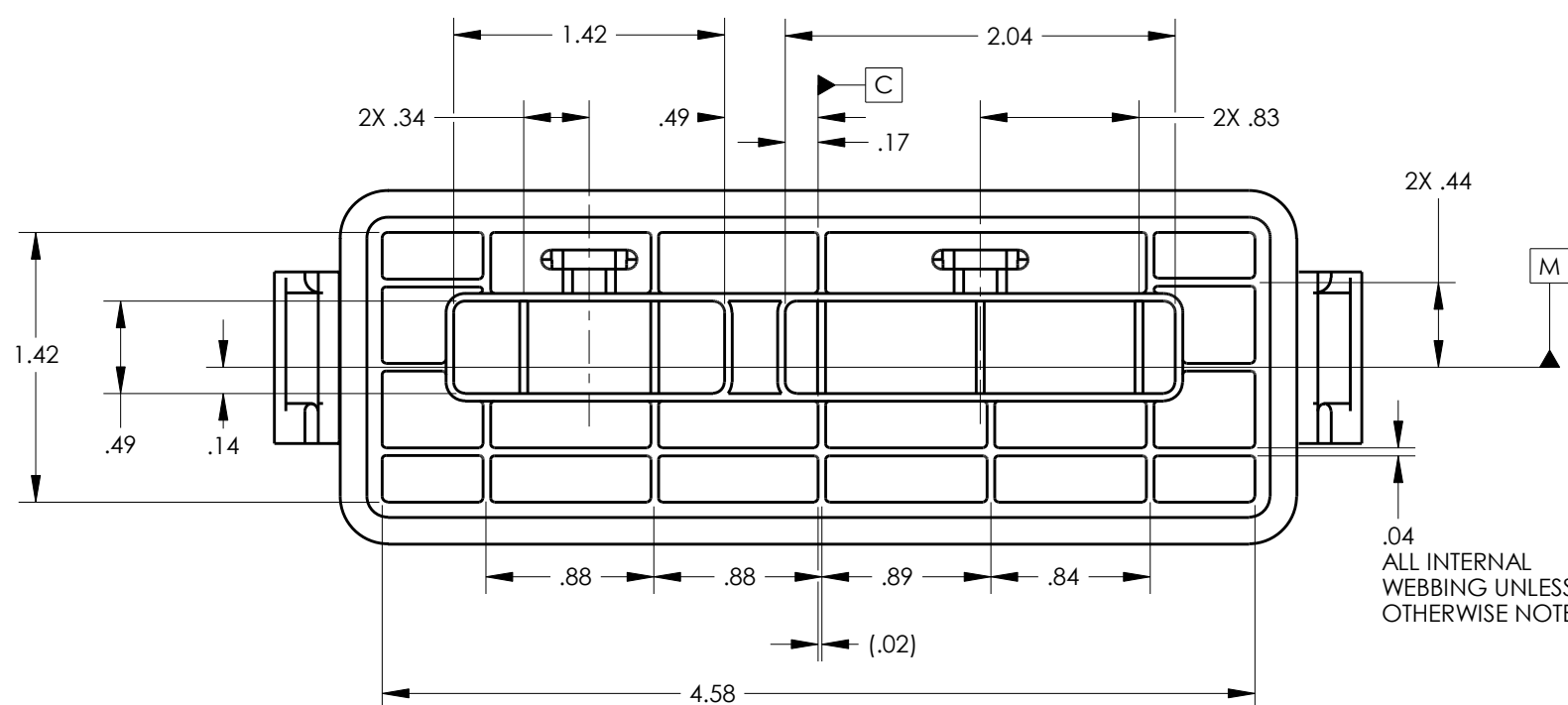

RoHS COMPLIANT

UNITS ENGLISH INCHES		DRAWN BY A. ECKHART		DATE		TITLE MODICE SE HEADER BLANK		MODELED BY: A. ECKHART 1700 FINLEY RD LOMBARD, IL. 60148	
DO NOT SCALE DRAWING		DESIGN ENGINEER		DESIGN ENGINEERING MGR.		MATERIAL		CONTROL SPEC NUMBER	
UNLESS OTHERWISE SPECIFIED: ALL DIMENSIONS ARE IN INCHES		MFG. ENGINEERING		QUALITY ASSURANCE		MATERIAL SPEC NUMBER		FINISH	
FILLET/RADII .02 MAX		TOLERANCES .X ± .1 .XX ± .01 .XXX ± .005 ANGULAR ± .5°		THIS DOCUMENT IS THE PROPERTY OF CINCH. NEITHER THIS DOCUMENT NOR ANY OF THE INFORMATION CONTAINED IN IT MAY BE DUPLICATED OR DISCLOSED WITHOUT PRIOR WRITTEN CONSENT OF CINCH.		CAD FILE NUMBER 5810000027S		DRAWING NUMBER 581 00 00 027 S	
						CAGE IDENT NO. 71785		SCALE 1:1	
						SIZE B		PROJECT NUMBER A14562	
								SHEET 1 OF 5	

PCB LAYOUT WITHOUT HEAT SINKS

PCB TOP SIDE GENERAL ZONING & KEEP OUT AREAS

PCB BOTTOM SIDE GENERAL ZONING & KEEP OUT AREAS

PCB OVERALL DIMENSIONS AND HOLE LOCATIONS

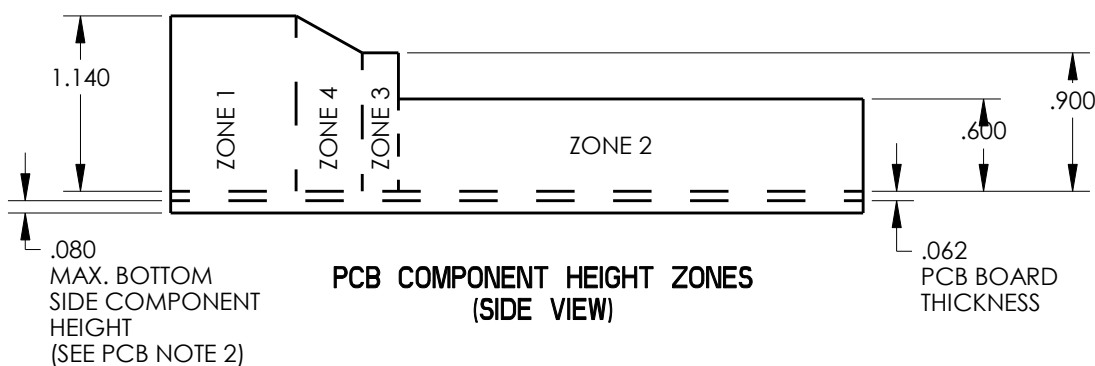
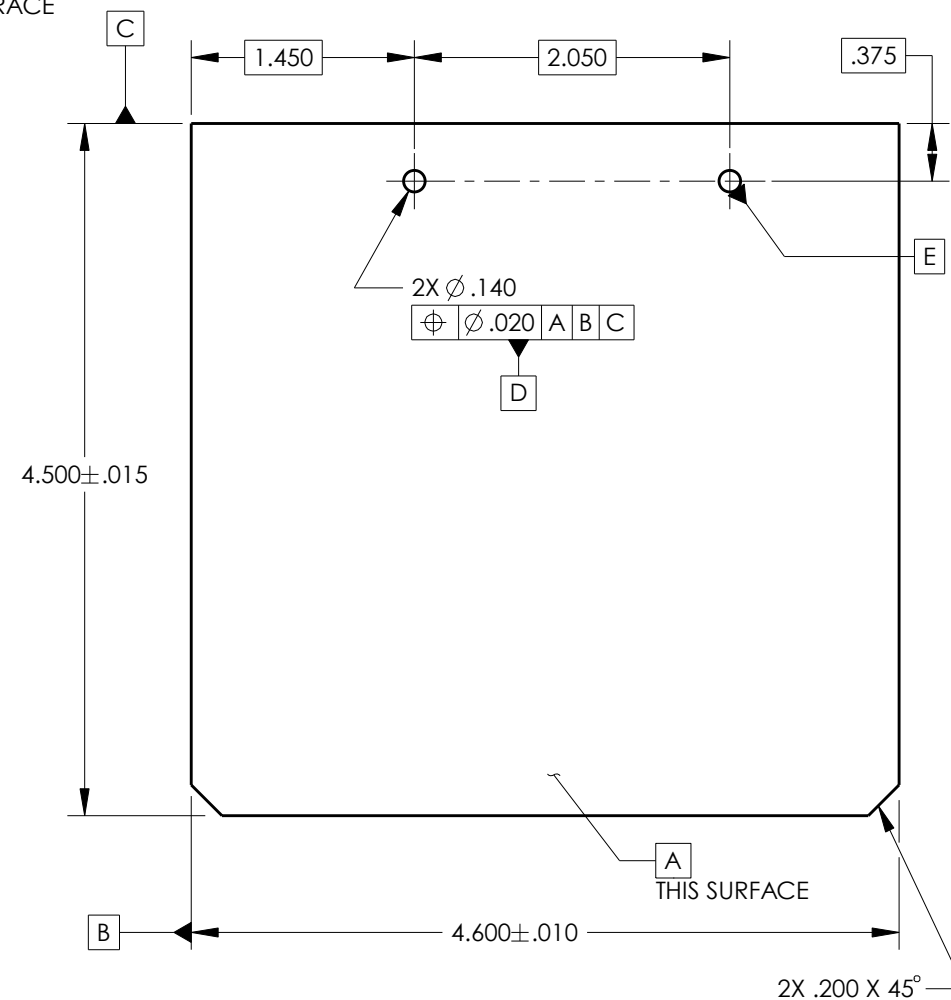
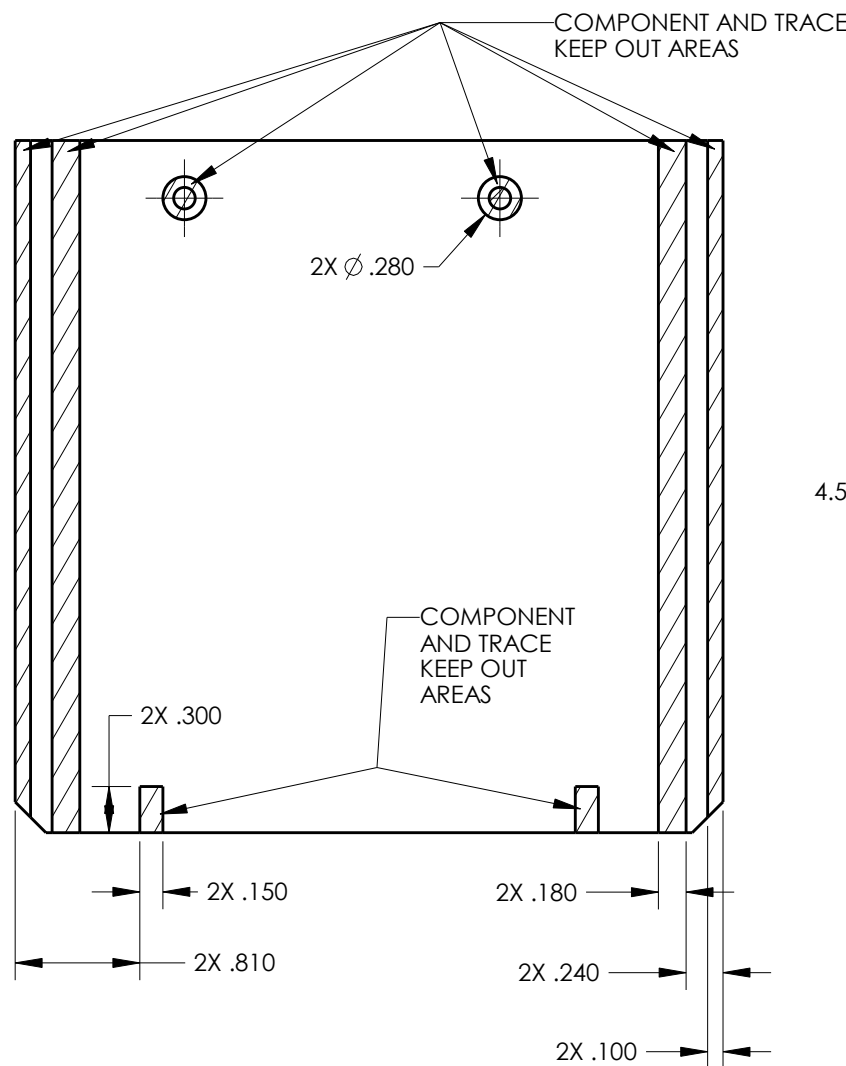
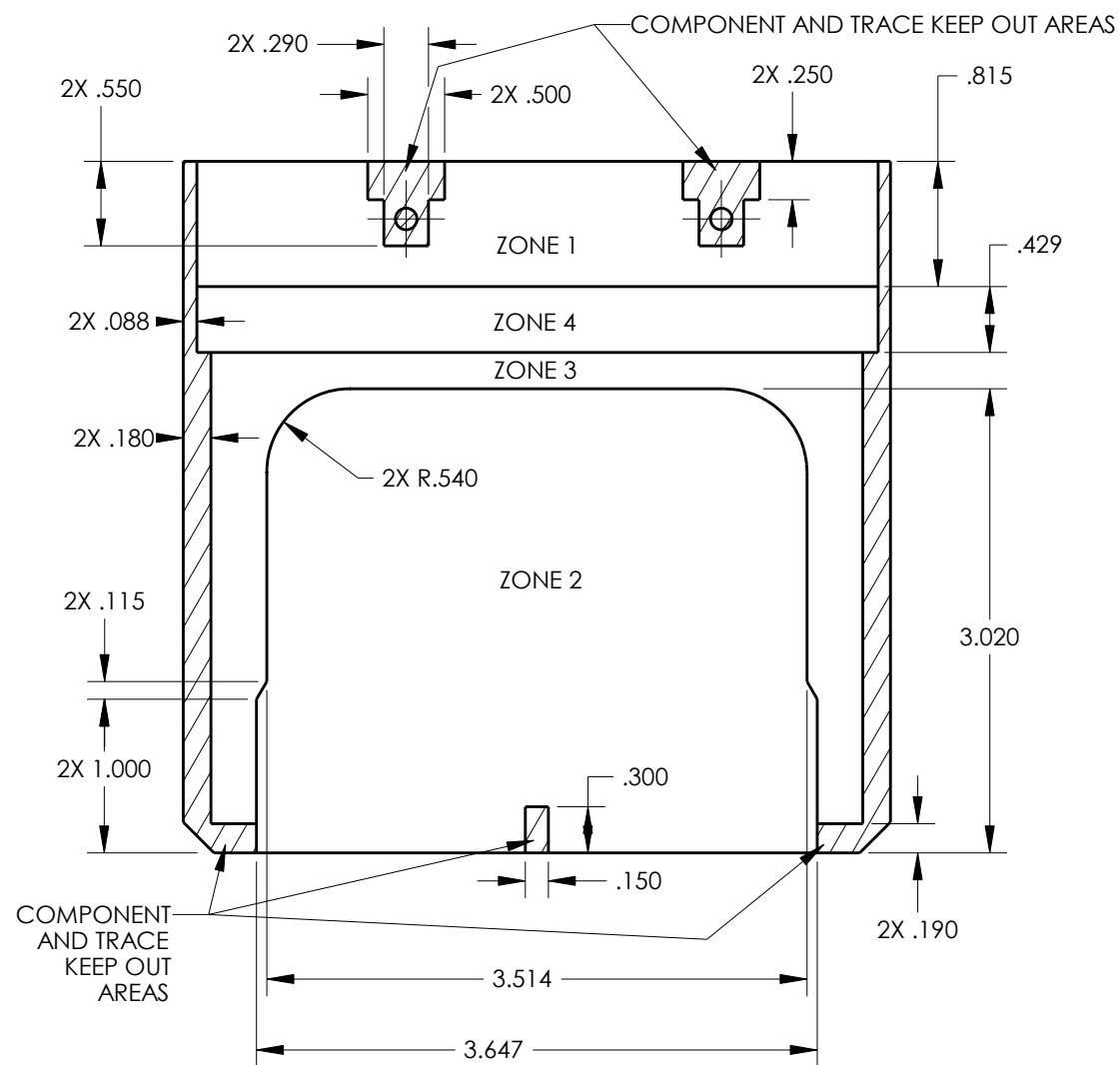

PCB COMPONENTS HEIGHT LIMIT

	ZONE 1	ZONE 2	ZONE 3	ZONE 4
MAX. HEIGHT FOR COMPONENTS (ABOVE PCB)	1.140"	.600"	.900"	SEE PCB NOTE 3

PCB NOTES:

- ON BOTTOM SIDE OF THE PCB, COMPONENTS OR TRACES MUST BE MIN. .100" AWAY FROM THE EDGE OF THE PCB.
- THE BOTTOM SIDE OF THE PCB SHOULD NOT HAVE COMPONENTS OR LEADS THAT EXTEND HIGHER THAN .080" (SEE PG. 5 SIDE VIEW).
- AREA HAS VARIABLE HEIGHT. SEE PCB COMPONENT HEIGHT ZONES VIEW FOR DETAILS.

UNITS
ENGLISH INCHES

DO NOT SCALE DRAWING

UNLESS OTHERWISE SPECIFIED:
ALL DIMENSIONS ARE IN INCHES

FILLET/RADIUS
.02 MAX

TOLERANCES
X ± .1
XX ± .01
XXX ± .005
ANGULAR ± .5°

THIS DOCUMENT IS THE PROPERTY OF CINCH. NEITHER THIS DOCUMENT NOR ANY OF THE INFORMATION CONTAINED IN IT MAY BE DUPLICATED OR DISCLOSED WITHOUT PRIOR WRITTEN CONSENT OF CINCH.

CINCH

1700 FINLEY RD
LOMBARD, IL 60148

TITLE
MODICE SE HEADER
BLANK

PRO/E DRAWING

CAD FILE NUMBER
5810000027S

CAGE IDENT NO.
71785

DRAWING NUMBER
581 00 00 027 S

REV
B

SCALE
~13:16

SHEET 2 OF 5

PCB LAYOUT WITH TWO HEAT SINKS

PCB TOP SIDE GENERAL ZONING & KEEP OUT AREAS

PCB BOTTOM SIDE GENERAL ZONING & KEEP OUT AREAS

PCB OVERALL DIMENSIONS AND HOLE LOCATIONS

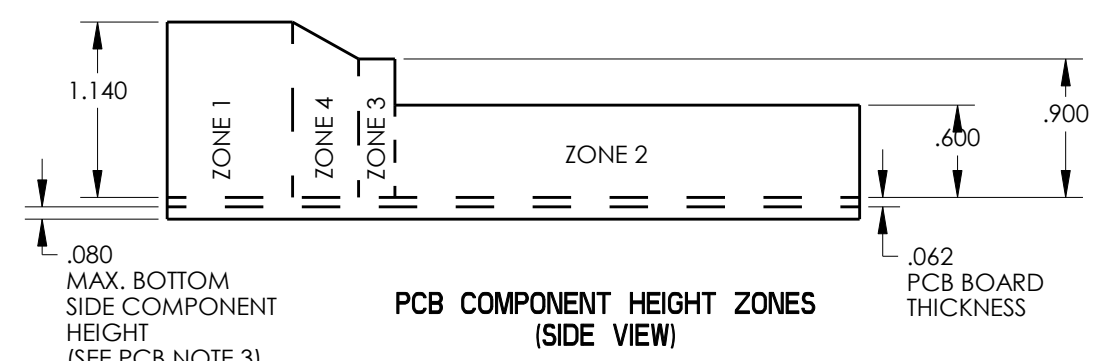
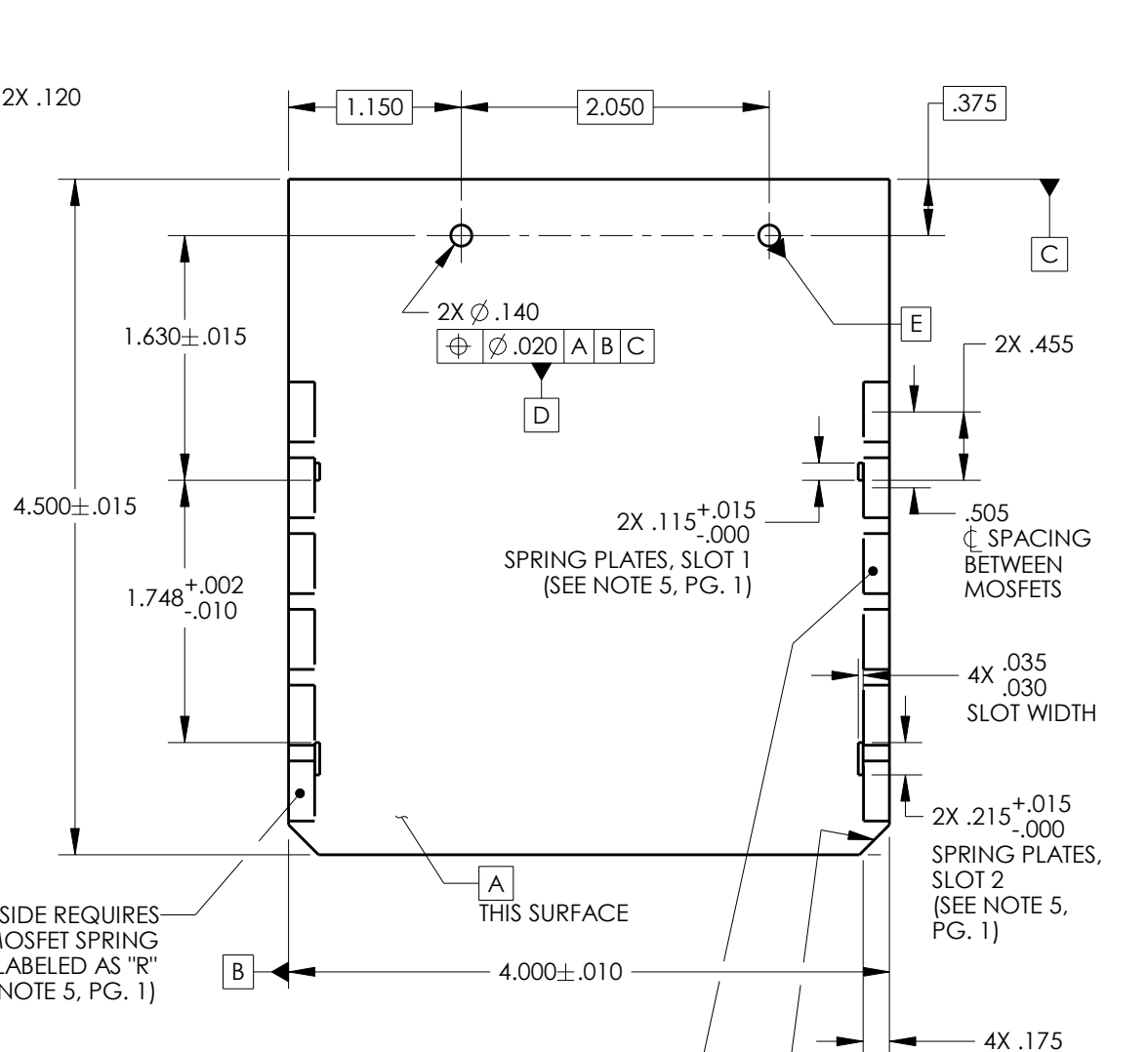
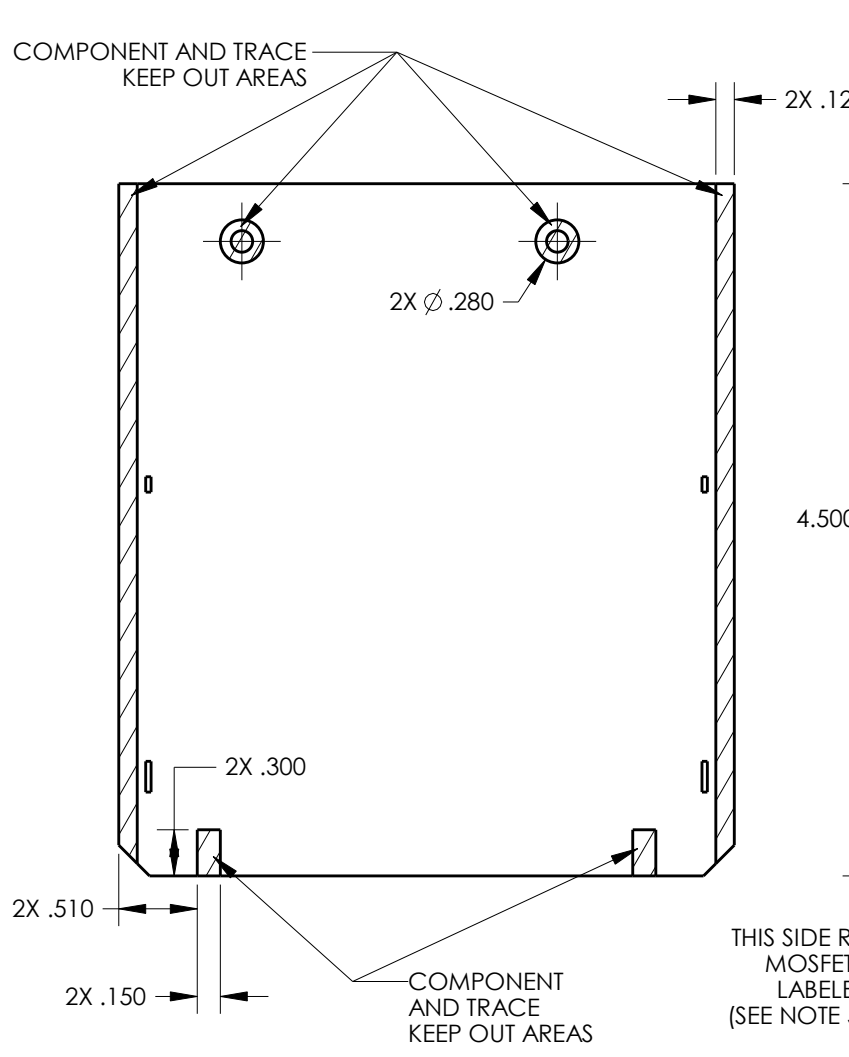
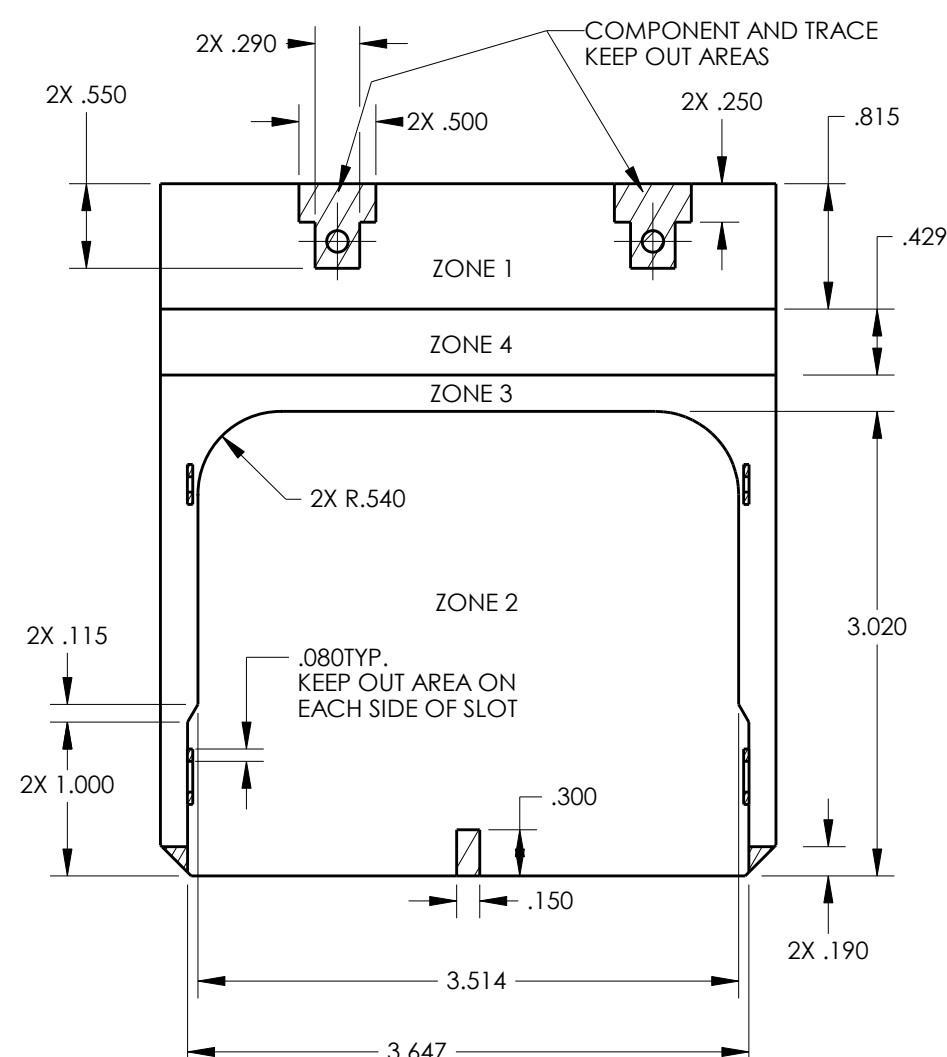

PCB COMPONENTS HEIGHT LIMIT				
	ZONE 1	ZONE 2	ZONE 3	ZONE 4
MAX. HEIGHT FOR COMPONENTS (ABOVE PCB)	1.140"	.600"	.900"	SEE PCB NOTE 4

- PCB NOTES:
- IF MOSFETS SPRINGS ARE USED, ZONE 3 SHOULD CONTAIN ONLY MOSFETS AND TRACES BETWEEN THE SPRINGS AND EDGE OF THE BOARD.
 - ON BOTTOM SIDE OF THE PCB, COMPONENTS OR TRACES MUST BE MIN. .100" AWAY FROM THE EDGE OF THE PCB.
 - THE BOTTOM SIDE OF THE PCB SHOULD NOT HAVE COMPONENTS OR LEADS THAT EXTEND HIGHER THAN .080" (SEE PG. 5 SIDE VIEW).
 - AREA HAS VARIABLE HEIGHT. SEE PCB COMPONENT HEIGHT ZONES VIEW FOR DETAILS.

THIS SIDE REQUIRES MOSFET SPRING LABELED AS "R" (SEE NOTE 5, PG. 1)

MOSFET LOCATION(S) MAX. 6 TO .220 STYLE MOSFETS PER SIDE THIS SIDE REQUIRES MOSFET SPRING LABELED AS "L" (SEE NOTE 5, PG. 1)

UNITS ENGLISH INCHES		CINCH		1700 FINLEY RD LOMBARD, IL. 60148	
DO NOT SCALE DRAWING		TITLE MODICE SE HEADER BLANK			
UNLESS OTHERWISE SPECIFIED: ALL DIMENSIONS ARE IN INCHES		DRAWING NUMBER 581 00 00 027 S			
FILLET/RADIUS .02 MAX		TOLERANCES X ± .1 XX ± .01 XXX ± .005 ANGULAR ± 5°		REV B	
THIS DOCUMENT IS THE PROPERTY OF CINCH. NEITHER THIS DOCUMENT NOR ANY OF THE INFORMATION CONTAINED IN IT MAY BE DUPLICATED OR DISCLOSED WITHOUT PRIOR WRITTEN CONSENT OF CINCH.		CAD FILE NUMBER 5810000027S	CAGE IDENT NO. 71785	SCALE ~13:16	SHEET 3 OF 5

PCB LAYOUT WITH ONE HEAT SINK

PCB TOP SIDE GENERAL ZONING & KEEP OUT AREAS

PCB BOTTOM SIDE GENERAL ZONING & KEEP OUT AREAS

PCB OVERALL DIMENSIONS AND HOLE LOCATIONS

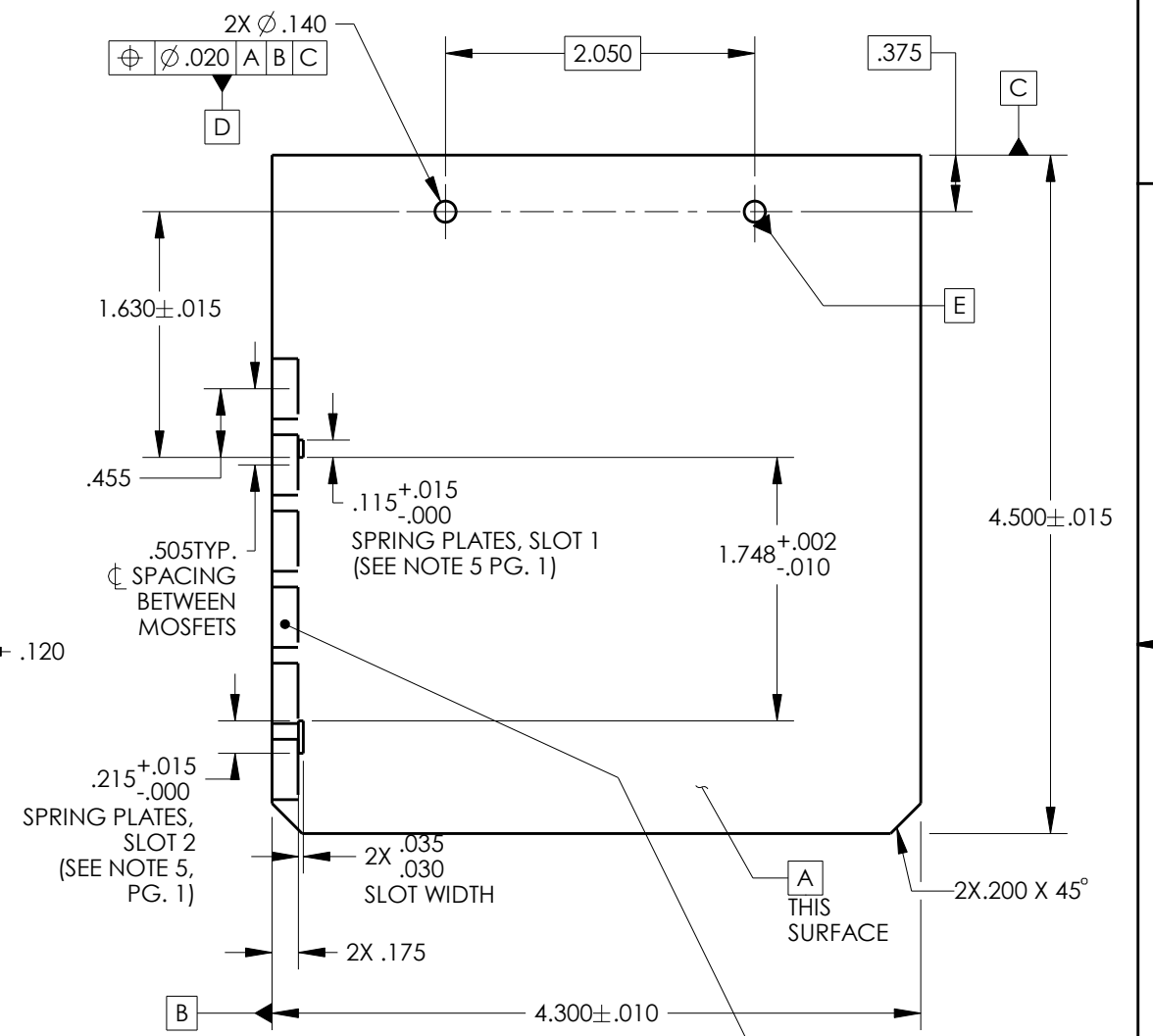
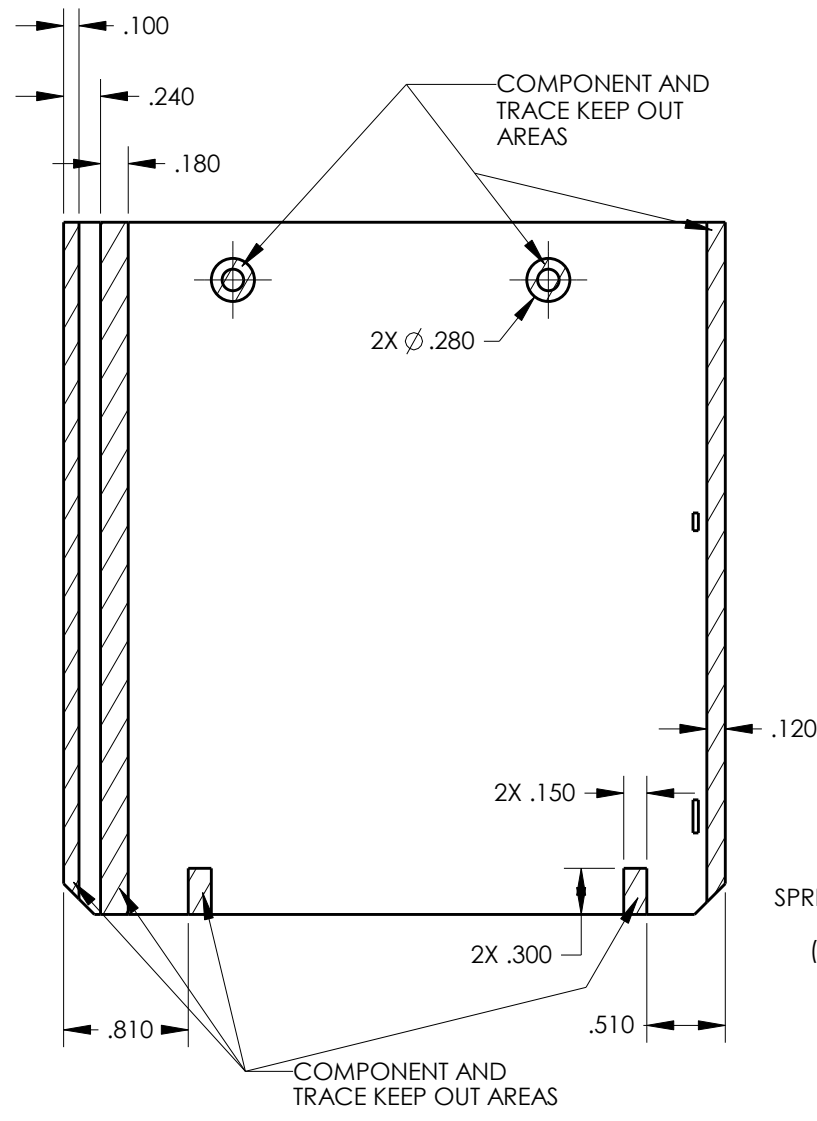
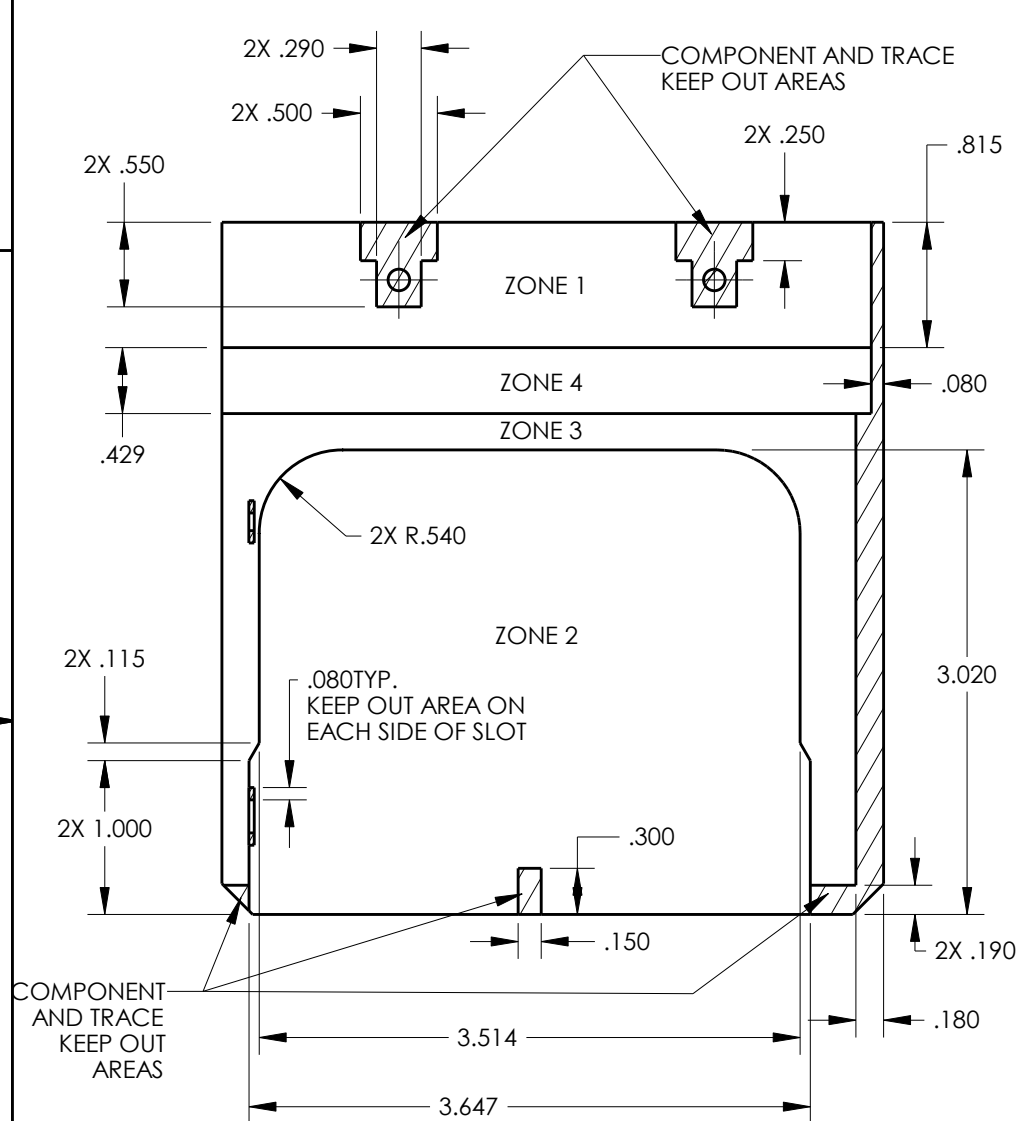

MOSFET LOCATION(S)
MAX. 6 TO-220 STYLE
MOSFETS THIS SIDE ONLY.
THIS SIDE REQUIRES
MOSFET SPRING LABELED
AS "R" (SEE NOTE 5 PG. 1)

PCB COMPONENTS HEIGHT LIMIT

	ZONE 1	ZONE 2	ZONE 3	ZONE 4
MAX. HEIGHT FOR COMPONENTS (ABOVE PCB)	1.140"	.600"	.900"	SEE PCB NOTE 4

- PCB NOTES:
- IF MOSFETS SPRINGS ARE USED, ZONE 3 SHOULD CONTAIN ONLY MOSFETS AND TRACES BETWEEN THE SPRINGS AND EDGE OF THE BOARD.
 - ON BOTTOM SIDE OF THE PCB, COMPONENTS OR TRACES MUST BE MIN. .100" AWAY FROM THE EDGE OF THE PCB.
 - THE BOTTOM SIDE OF THE PCB SHOULD NOT HAVE COMPONENTS OR LEADS THAT EXTEND HIGHER THAN .080" (SEE PG. 5 SIDE VIEW).
 - AREA HAS VARIABLE HEIGHT. SEE PCB COMPONENT HEIGHT ZONES VIEW FOR DETAILS.

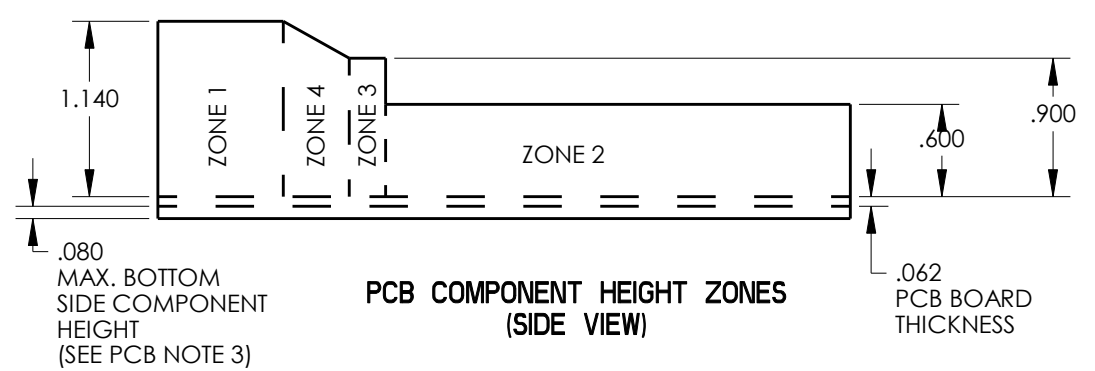

UNITS ENGLISH INCHES		CINCH		1700 FINLEY RD LOMBARD, IL. 60148	
DO NOT SCALE DRAWING		TITLE MODICE SE HEADER BLANK			
UNLESS OTHERWISE SPECIFIED: ALL DIMENSIONS ARE IN INCHES		DRAWING NUMBER 581 00 00 027 S			
FILLET/RADIUS .02 MAX		TOLERANCES X ± .1 XX ± .01 XXX ± .005 ANGULAR ± .5°		REV B	
THIS DOCUMENT IS THE PROPERTY OF CINCH. NEITHER THIS DOCUMENT NOR ANY OF THE INFORMATION CONTAINED IN IT MAY BE DUPLICATED OR DISCLOSED WITHOUT PRIOR WRITTEN CONSENT OF CINCH.		CAD FILE NUMBER 5810000027S	CAGE IDENT NO. 71785	SCALE ~13:16	SHEET 4 OF 5

8

7

6

5

4

3

2

1

D

D

APPLY THIN BEAN OF THERMALLY CONDUCTIVE ADHESIVE PASTE TO ENTIRE MOSFET SURFACE. (SEE NOTE 5)

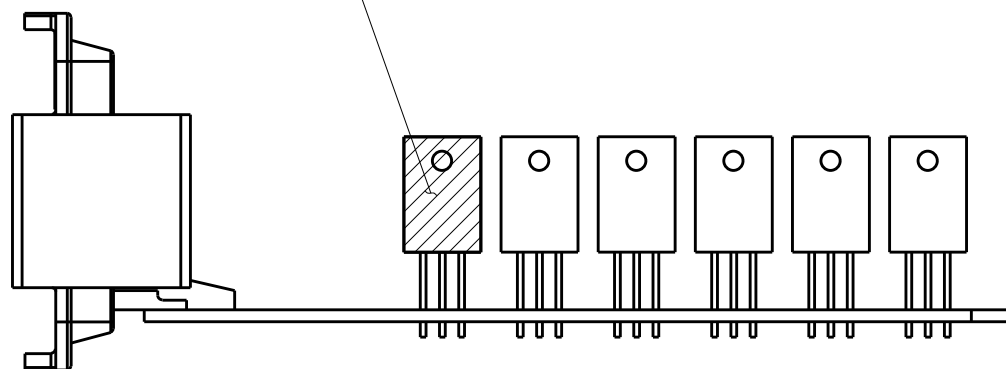

SIDE VIEW
REQUIRED TO-220 PACKAGE PROFILE

FOR EASE OF ASSEMBLY, IT IS RECOMMENDED THAT MOSFET(S) BE TILTED UP TO 10° IN POSITIVE DIRECTION (SEE DOTTED LINE)

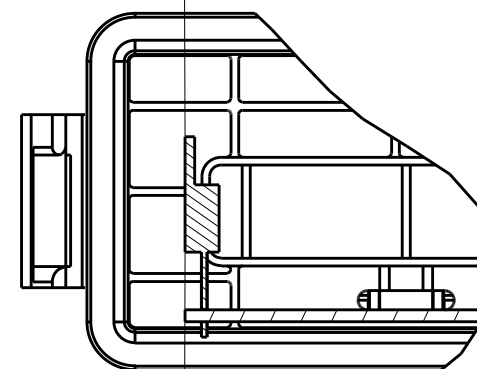

MOSFET MUST LIE IN THE SAME PLANE WITH EDGE OF PCB (AS SHOWN)

REQUIRES TO-220 PACKAGING PROFILE
PARTIAL SECTION B-B

C

C

B

B

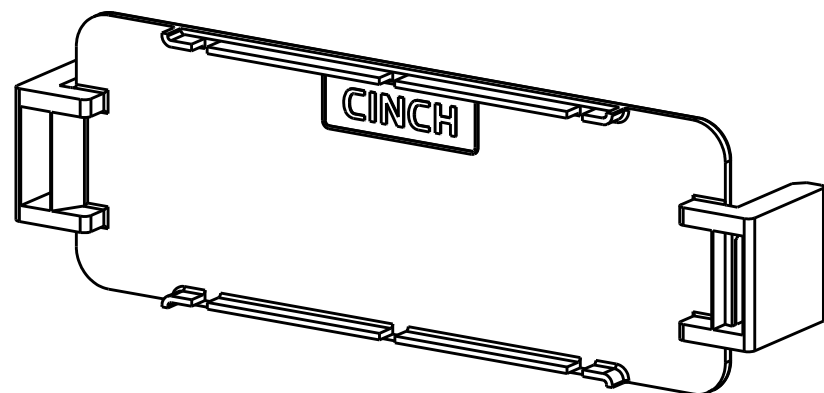

SCALE -13:16

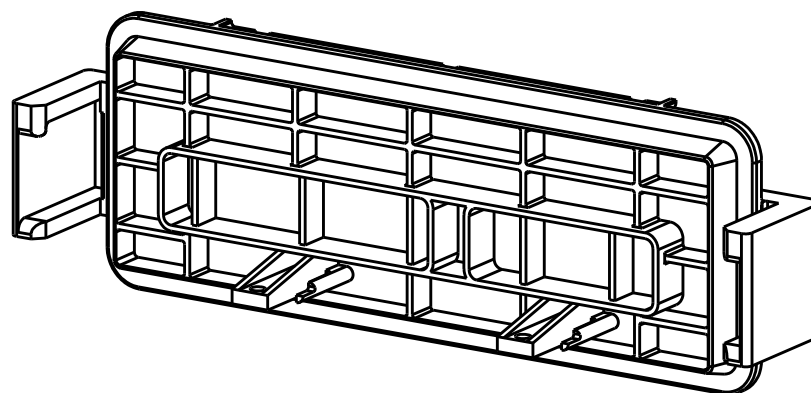

SCALE -13:16

A

8

7

6

5

4

3

2

1

UNITS ENGLISH INCHES		CINCH		1700 FINLEY RD LOMBARD, IL. 60148	
DO NOT SCALE DRAWING		TITLE MODICE SE HEADER BLANK			
UNLESS OTHERWISE SPECIFIED: ALL DIMENSIONS ARE IN INCHES		SCALE PRO/E DRAWING			
FILLET/RADIUS .02 MAX	TOLERANCES .X ± .1 .XX ± .01 .XXX ± .005 ANGULAR ± .5°	CAD FILE NUMBER 5810000027S	DRAWING NUMBER 581 00 00 027 S	REV B	
THIS DOCUMENT IS THE PROPERTY OF CINCH. NEITHER THIS DOCUMENT NOR ANY OF THE INFORMATION CONTAINED IN IT MAY BE DUPLICATED OR DISCLOSED WITHOUT PRIOR WRITTEN CONSENT OF CINCH.		CAGE IDENT NO. 71785	SCALE 1:1	SHEET 5 OF 5	

X-ON Electronics

Largest Supplier of Electrical and Electronic Components

Click to view similar products for [Automotive Connectors](#) category:

Click to view products by [Bel Fuse](#) manufacturer:

Other Similar products are found below :

[003-018-000](#) [60403001](#) [60993906-B](#) [M902-2131](#) [M902-2161](#) [M902-2344](#) [72.330.1035.1](#) [73.353.4028.0](#) [F119300-B](#) [F166900](#) [F258300-B](#)
[F358300-B](#) [F407400](#) [F444110](#) [F487000](#) [F509500B-B](#) [827153-1](#) [8N1515-32-24P](#) [9-1326729-8](#) [925474-1](#) [928905-1](#) [964562-4](#) [968782-1](#)
[GT17SA-8DS-HU](#) [98891-1012](#) [98947-1016](#) [12004147](#) [12004475-L](#) [12010290](#) [12010309-B](#) [12015454](#) [12020219-B](#) [12041318-B](#) [12052225-](#)
[L](#) [12052466](#) [12064869](#) [12004327-B](#) [12015308](#) [12015384](#) [12015909](#) [1-21030-1](#) [12041254](#) [12041318](#) [12047946-B](#) [12047957](#) [12047957-L](#)
[12059473](#) [12066261](#) [12110546](#) [12110546-B](#)