



F & FC Series

DC-DC Converter Input Filters

Bel Power Solutions offers a complete range of input filters to help control EMI in board-level DC-DC converter applications. The table below lists combinations of input filters and DC-DC converters that have test data available. These test results are presented only to provide general guidelines, as EMI issues vary considerably based on many variables specific to each application. Due to the large number of possible permutations of DC-DC converters and input filters, not all combinations have been tested. Therefore, please refer to the data presented for each filter to select filters that may work in combinations not specified below.



DC-DC CONVERTER SERIES	TESTED WITH FILTER MODEL NUMBERS		PAGE
Q24	F2410		2, 7
Q48	F4804A, F4810		2, 7
QD48	F4804A, F4810		2, 7
QL48	F4804A, F4810		2, 7
SQ24	F2410		2, 7
SQ48	F4804A, F4810		2, 7
SQE48	F4804A, F4810		2, 7
SQM48	F4804A, F4810		2, 7
QM48	F4810		7
QME48	F4810		7
SQT48	F4810		7
FES	FC100V20A	Last Time Buy	13
HBD	FC100V5A	Last Time Buy	13
HES	FC100V5A	Last Time Buy	13
IAD	FC100V5A	Last Time Buy	13
IAS	FC100V5A	Last Time Buy	13
IES	FC100V5A	Last Time Buy	13
LES	FC100V5A	Last Time Buy	13
OET	FC100V5A	Last Time Buy	13
QBS	FC100V5A	Last Time Buy	13
QES	FC100V5A	Last Time Buy	13

F4804A, 0-80 VDC, 4 A, SMT

The **F4804A** Input Filter minimizes the conducted and radiated emissions generated by switch mode DC-DC converters, and allows board designs utilizing DC-DC converters to meet stringent FCC and EN55022 Class B conducted emissions requirements.

Unlike most available off-the-shelf filter modules, the F4804A, in addition to common mode noise reduction components, is provisioned with a differential LC-filter stage, which virtually guarantees compliance with conducted noise standards across the frequency range from 150 kHz to 30 MHz, including fundamental switching frequency and its harmonics. Test results show headroom of 15-20 dB for conducted noise quasi-peak levels, in relation to Class B requirements.

F4804A filter is designed specifically for distributed power solutions in conjunction with DC-DC converters. Low profile and small size (only 0.75 sq. in.) in a surface mount package helps the designer save system board real estate, and simplifies the layout.

A single filter can be used with multiple converters, and is capable of providing up to 4 A to the converter input bus at 85 °C. When used as specified within this data sheet, these filters do not require airflow and/or derating at high temperatures.

Features

- RoHS lead free solder and lead solder exempted products are available
- Maximum current 4 A with no derating
- Maximum operating input voltage 80 V
- 100 V 100 mS transient withstand capability
- Differential LC-filter stage
- Surface mounted design
- Small footprint – only 0.75 sq. inch
- Low profile: 0.267 inch [6.7 mm] maximum
- Low weight: 0.13 oz [3.66 g]
- Operation over -40°C to 85 °C ambient temperature range
- No airflow required up to 85 °C
- Enables DC-DC converter compliance with EN55022 and FCC Class B requirements conducted emissions
- Approved to the latest revision of safety standards: UL/CSA60950-1

Applications

Differential and Common Mode filtering for DC-DC converters:

- Telecommunications
- Data communications
- Distributed Power Solutions

1 ELECTRICAL SPECIFICATIONS

Conditions: TA = 25 °C, No Airflow, Vin = 48 VDC, unless otherwise specified.

PARAMETER	NOTES	MIN	TYP	MAX	UNITS
Absolute Maximum Ratings					
Input Voltage	Continuous	0		100	VDC
Operating Ambient Temperature		-40		85	°C
Storage Temperature		-55		125	°C
Electrical Characteristics					
Operating Input Voltage Range		0	48	80	VDC
Maximum Operating Current	85 °C ambient, no airflow			4	ADC
DC Resistance (total for two legs)			0.07		Ω
Filter differential inductance			5		μH
Filter common mode inductance	For frequencies below 10 MHz		60		μH
Differential mode Attenuation at 400 kHz ¹			35		dB
Differential mode attenuation at 30 MHz ¹			56		dB
Common mode Attenuation at 400 kHz ²			50		dB
Common mode Attenuation at 30 MHz ²			60		dB
Efficiency at Maximum Load	Vin = 48V @ 4 A	99.2	99.4		%

The F4804A filter contains input and output capacitors, plus differential and common mode inductors. The separate differential inductor, L2, allows a differential attenuation of 55 dB, a value substantially higher in comparison with other available off-the-shelf filters (typically 25-30 dB).

Absolute maximum voltage and maximum operating voltage in Electrical Specifications Table are for the filter itself; check maximum rating for corresponding DC-DC converters. Filter will not be damaged by reversed input voltage, or by applying voltage to the output pins.

Figure 1 - Schematic Diagram

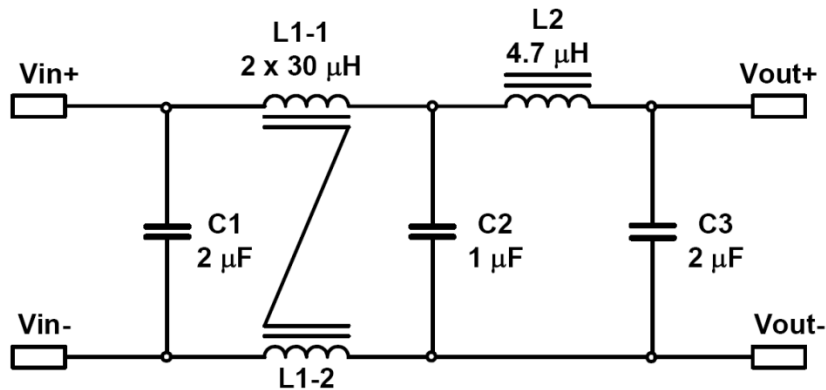

¹ 50 Ω source and 50 Ω load impedance. See Figure 2 for differential mode attenuation in 50 kHz-100 MHz frequency range.

² 50 Ω source and 50 Ω load impedance; external common-mode capacitors 0.47 μF (from IN+ and IN- to the common chassis). See Figure 3 and Figure 4 for attenuation in 50 kHz-100 MHz frequency range.

Differential attenuation plot in the frequency range of 50 kHz-100 MHz is shown in Figure 2, and can be seen to be flat (around 55-60 dB) from 0.5 MHz to 50 MHz.

Figure 2 - Differential mode attenuation, 0.05-100 MHz. Source and load resistances are 50 Ω. Vertical scale: 20 dB/div, with zero level marked by arrow. No load @ 25 °C



Figure 3 and Figure 4 show Common mode attenuation with 50 Ω source and load. The attenuation depends on the value of external Y-capacitors, connected between input pins and frame or a reference ground.

Figure 3 - Common Mode attenuation, 0.05-100 MHz. Source and load resistances are 50 Ω. Two 0.1 μF Y-caps to common line. Vertical scale: 20 dB/div, with zero dB level marked by arrow.



Figure 4 - Common Mode attenuation, 0.05-100 MHz. Source and load resistances are 50 Ω. Two 0.47 μF Y-caps to common line. Vertical scale: 20 dB/div, with zero dB level marked by arrow.



2 THERMAL CONSIDERATIONS

Because of low series internal DC resistance, the F4804A filter generally does not require airflow and/or derating to ambient temperatures up to 85 °C, if placed and interconnected as described below.

Good thermal design includes the appropriate placement of the filter on the system board as to maximize heat exchange through the power pins. For high temperature operation in low airflow environments, use of 1-2 oz copper for the external connection pads and provision for some extra copper at all four I/O pins is encouraged. Good thermal connection to the power planes is important.

To check filter thermal characteristic in an actual system environment, attach a thermocouple to the top of each inductor. The maximum temperature at these test points should not exceed 120 °C.

A typical application schematic is shown in Figure 5. The filter can be used to Bel Power Solutions or more converters.

For applications requiring filter current greater than 4 A divide the converters into smaller groups and use multiple filters or use a F4810 or F2410 filter which is capable of providing up to 10 A. Do not connect filters in parallel.

Figure 5 - F4804A - Typical Application

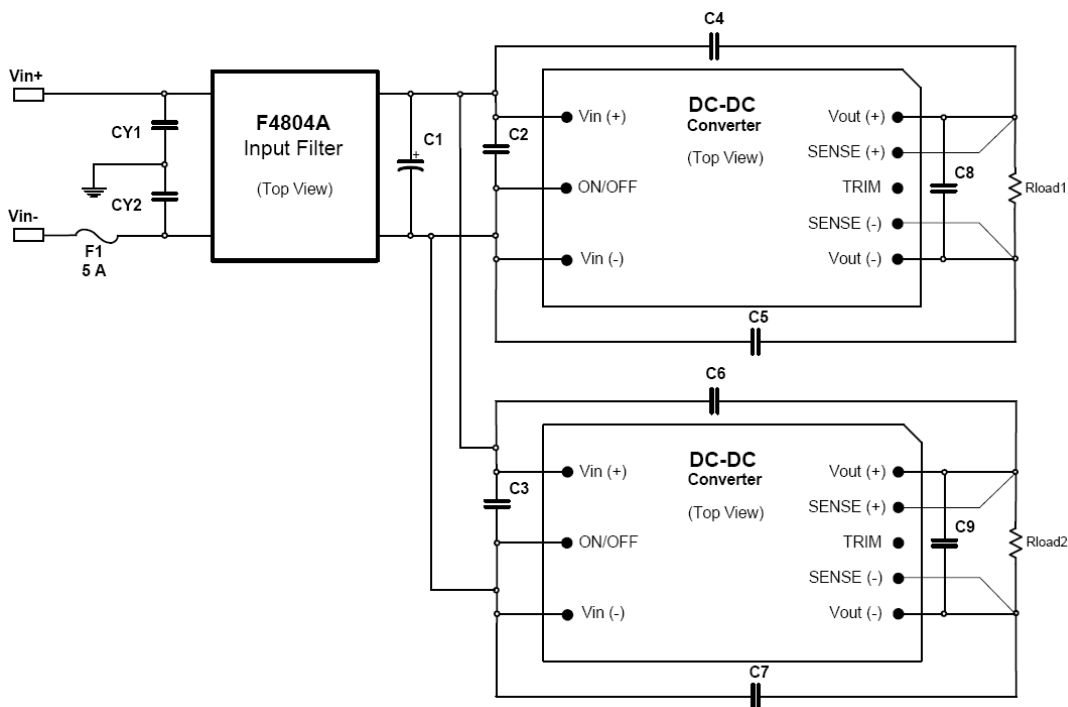

For additional information regarding layout and EMC, refer to the Layout Considerations and EMI Considerations Application notes.

The following bulleted items are considerations regarding the external components for the typical application shown in Figure 5.

- Input electrolytic capacitor C1. We recommend 1-2 $\mu\text{F}/\text{W}$ for 48 V applications. This capacitor is needed to ensure stability of converters in presence of their negative input impedance characteristic. Note that electrolytic capacitors at -40 °C have 3-5 times less capacitance than at room temperature, and therefore it is good practice to check the power system at worst case conditions from this point of view, i.e. lowest ambient temperature, minimum input voltage, and maximum load. If electrolytic capacitors are restricted for use in the system, please contact the factory.
- Input capacitors C2, C3 are optional; they decrease input ripple current and improve EMI. One or two of the following ceramic chip capacitors per converter are recommended:
–TDK C4532X7R2A105, 1.0 μF , 100 V

F & FC Series Input Filters

F4804A, 0-80 VDC, 4 A, SMT

- Common-mode capacitor (Y-cap) values and their EMI attenuation effects depend on system grounding and layout. If connection of capacitors between input and output is prohibited because of system restrictions, connect Y-capacitors only from each input pin to system ground (CY1 and CY2 on Figure 5). The value of these capacitors in this case is “the bigger the better” (preferably 0.1µF or larger). Voltage rating of Y-capacitors depends on the system isolation and safety requirements.
- Output capacitors C8, C9 are optional to reduce output ripple. Addition of one-two 47µF ceramic capacitors, for example, for low voltage applications 3.3 V and below, significantly decreases output ripple from 25-40 mV peak-to-peak to 5-10 mV. Recommended capacitor for these low voltage applications is C3225X5R0J476 from TDK.
- F4804A filter should be protected with a 5 Amps fuse (R451005 from Littelfuse). Smaller value fuses can be used as required for protection to a lower power limit.

3 PHYSICAL INFORMATION

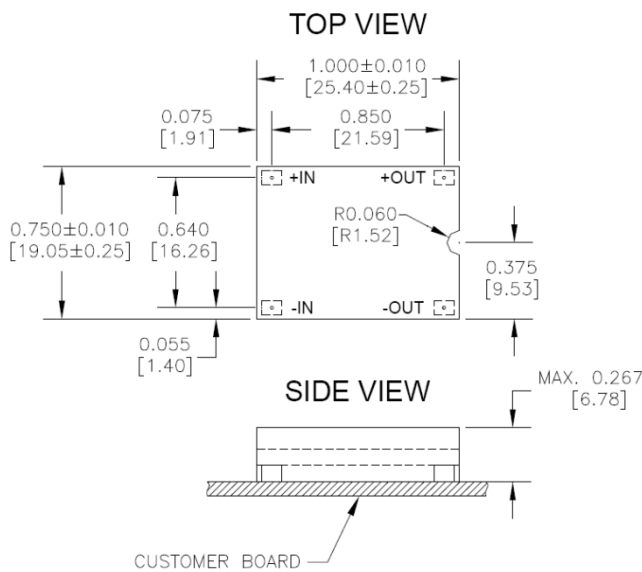

PAD/PIN CONNECTIONS	
PAD/PIN #	FUNCTION
+IN	Vin (+)
-IN	Vin (-)
-OUT	Vout (-)
+OUT	Vout (+)

- All dimensions are in inches [mm]
- Connector Material: Copper
- Connector Finish: Gold over Nickel
- Converter Weight: 0.13 oz [3.66 g]
- Recommended Surface-Mount Pads:
Min. 0.080" x 0.112" [2.03 x 2.84]
Max. 0.092" x 0.124" [2.34 x 3.15]

4 FILTER PART NUMBERING ORDERING INFORMATION

PRODUCT SERIES	INPUT VOLTAGE	RATED LOAD CURRENT	TAPE AND REEL	ENVIRONMENTAL
F	48	04A	-	R
Filter Module	≤ 80 V	4 A	No letter ⇒ Bulk R ⇒ Tape and Reel	G ⇒ RoHS compliant for all six substances

The example above describes P/N F4804A-R: 0-80 V input, 4 A @ 80 V output, tape and reel, and Eutectic Tin/Lead solder. Please consult factory for the complete list of available options and G option RoHS.



Asia-Pacific
+86 755 298 85888

Europe, Middle East
+353 61 225 977

North America
+1 408 785 5200

F & FC Series Input Filters

F2410 & F4810, 0-45 VDC/0-80 VDC 10 A, SMT



Features

- RoHS lead free solder and lead solder exempted products are available
- Maximum current 10 A with no derating
- Maximum operating input voltage 80 V (45 V for F2410 version)
- 100 V/50 V 100 mS transient withstand capability
- Differential LC-filter stage
- Surface mounted design
- Small footprint – less than 1 sq. inch
- Low profile: 0.378 inch [9.6 mm] maximum
- Low weight: 0.34 oz [9.5 g]
- Operation over -40 °C to 85 °C ambient temperature range
- No airflow required up to 85 °C
- Enables DC-DC converter compliance with EN55022 and FCC Class B requirements conducted emissions
- Approved to the latest revision of safety standards: UL/CSA60950-1

The **F4810** and **F2410** Input Filters minimize the conducted and radiated emissions generated by switch mode DC-DC converters, and allow board designs utilizing DC-DC converters to meet stringent FCC and EN55022 Class B conducted emissions requirements.

Unlike most available off-the-shelf filter modules, the F4810 and F2410, in addition to common mode noise reduction components, are provisioned with a differential LC-filter stage, which virtually guarantees compliance with conducted noise standards across the frequency range from 150 kHz to 30 MHz, including fundamental switching frequency and its harmonics. Test results show headroom of 15-20 dB for conducted noise quasi-peak levels, in relation to Class B requirements.

F4810/F2410 filters are designed specifically for distributed power solutions in conjunction with dc-dc converters. Low profile and small size (less than 1 sq. in.) in a surface mount package helps the designer save system board real estate, and simplifies the layout.

A single filter can be used with multiple converters, and is capable of providing up to 10 A to the converter input bus at 85°C. When used as specified within this data sheet, these filters do not require airflow and/or derating at high temperatures.

Applications

Differential and Common Mode filtering for DC-DC converters with 48 V and 24 V input:

- Telecommunications
- Data communications
- Distributed Power Solutions

1 ELECTRICAL SPECIFICATIONS

Conditions: TA = 25 °C, No Airflow, Vin = 48 VDC, unless otherwise specified.

PARAMETER	NOTES	MIN	TYP	MAX	UNITS
Absolute Maximum Ratings					
Input Voltage (F4810)	Continuous	0		100	VDC
(F2410)	Continuous	0		50	VDC
Operating Ambient Temperature		-40		85	°C
Storage Temperature		-55		125	°C
Electrical Characteristics					
Operating Input Voltage Range (F4810)		0	48	80	VDC
(F2410)		0	24	45	VDC
Maximum Operating Current	85 °C ambient, no airflow			10	ADC
DC Resistance (total for two legs)			0.016		Ω
Filter differential inductance			4.5		H
Filter common mode inductance	For frequencies below 10 MHz		6.5		H
Differential mode Attenuation at 400 kHz ³	F4810		57		dB
	F2410		63		dB
Differential mode attenuation at 30 MHz ¹	F4810		56		dB
	F2410		57		dB
Common mode Attenuation at 400 kHz ⁴	F4810, F2410		24		dB
Common mode Attenuation at 30 MHz ²	F4810, F2410		50		dB
Efficiency at Maximum Load	Vin = 48 V @ 10 A	99.6	99.7		%

The F4810 and F2410 filters contain input and output capacitors, plus differential and common mode inductors. Shown in Figure 1, the schematic diagrams of both filters are similar, the only difference are changes in C1, C2 capacitor values. The separate differential inductor, L2, allows a 50 Ω differential attenuation of 60 dB across the stated frequency range, a value substantially higher in comparison with other available off-the-shelf filters (typically 25-30 dB).

The F4810 can be used in 24 V or 48 V systems without any limitations; however, in 24 V systems the F2410 differential attenuation is better. At low frequencies around 100-200 kHz the difference is 20 dB, but at high frequencies the plots are close to identical.

Absolute maximum voltage and maximum operating voltage in Electrical Specifications Table are for the filter itself; check maximum rating for corresponding DC-DC converters. The filter will not be damaged by reversed input voltage, or by applying voltage to the output pins.

Figure 1 - Schematic diagram for F4810, F2410. The Capacitor values shown are for F4810; for F2410 C1=10 μF; C2=13 μF.

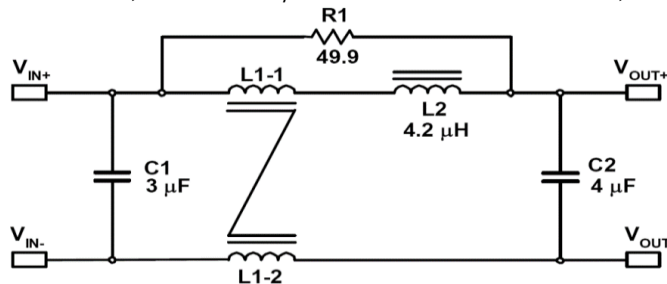

³ 50 Ω source and 50 Ω load impedance. See Figure 2 and 3 for differential mode attenuation in the 20 kHz-100 MHz frequency range.

⁴ 50 Ω source and 50 Ω load impedance; external common-mode capacitors 0.1 μF (from IN+ and IN- to the common chassis). See Figure 4 for attenuation in the 20 kHz-100 MHz frequency range.

Figure 2 - F4810 - Differential mode attenuation, 0.2-100 MHz. Source and load resistances are 50 Ω. Vertical scale: 10 dB/div, with zero level marked by arrow. No load, 25 °C

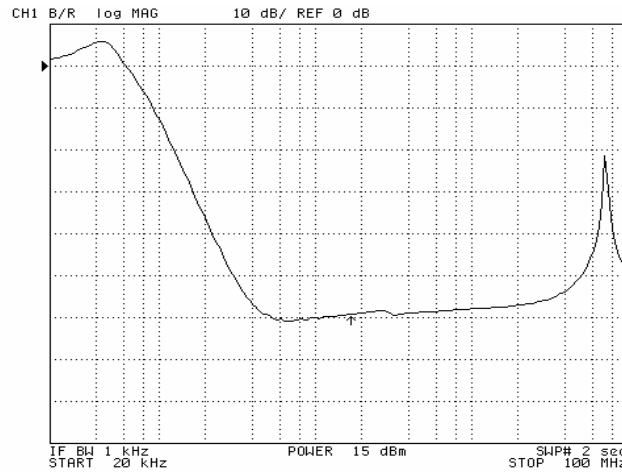

Differential attenuation plots for the F4810 and F2410 filters in the extended frequency range of 20 kHz-100 MHz are shown in Figure 2 and Figure 3, respectively, and can be seen to be flat (around 55-60 dB) from 0.35 MHz to 40 MHz.

Figure 4 shows Common mode attenuation with 50 Ω source and load. The attenuation is the same for both filters, and depends on the value of external Y-capacitors, connected between input pins and frame or a reference ground.

Figure 3 - F2410 - Differential mode attenuation, 0.2-100 MHz. Source and load resistance 50 Ω. Vertical scale: 10 dB/div, with zero level marked by arrow. No load, 25 °C.

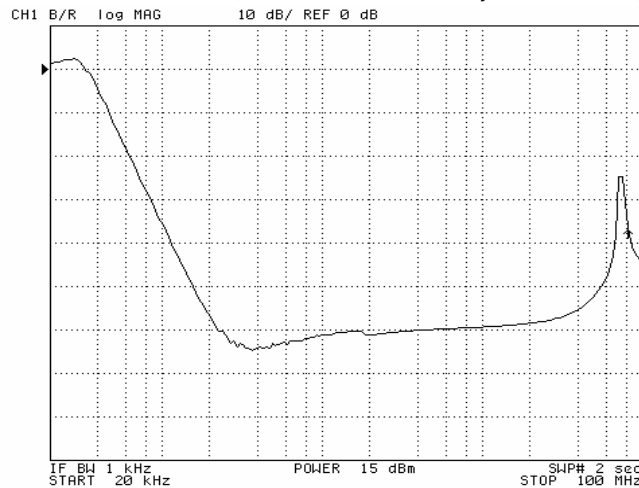

Figure 4 - F4810/F2410 - Common Mode attenuation, 0.2-100 MHz. Source and load resistances are 50 Ω. Two 0.1 uF Y- caps to common line. Vertical scale: 10 dB/div, with zero dB level marked by arrow.



2 THERMAL CONSIDERATIONS

Because of low series internal DC resistance, the F4810/F2410 filters generally do not require airflow and/or derating to ambient temperatures up to 85 °C, if placed and interconnected as described below.

Good thermal design is consistent with appropriate placement to gain additional heat exchange through the I/O pins to the system board. For high temperature operation in low airflow environments, use of 1-2 oz copper for the external connection pads and provision for some extra copper at all four I/O pins is encouraged. Thermal derating data shown were taken on special thermal board with each input and output pin connected to 0.5 sq. in pad of 2 oz copper.

To check filter thermal characteristic in an actual system environment, attach a thermocouple to the top of differential inductor, L2; it is the INDUCTOR closest to OUT+ pin.

The maximum temperature at this test point should not exceed 120 °C, and a minimum of 5-10 °C headroom is suggested for better reliability.

A typical application schematic is shown in Figure 5. Either filter can be used to Bel Power Solutions or more converters. Maximum filter output current should be limited 10 A - or less - depending upon system thermal environment.

The required filter current drawn by the converter loads, $I_{REQ'd}(\text{Filter})$, will be the sum of the loads of all connected converters:

$$I_{REQ'd}(\text{filter}) = \Sigma [P_{i,OUT} / (V_{IN, min} * \eta_{i, min})] \quad [A]$$

where:

$I_{REQ'd}(\text{filter})$	maximum required filter current
$P_{i,OUT}(\text{converter})$	converter output power, i=1, 2... = $V_{i,OUT}(\text{converter}) * I_{i,OUT}(\text{converter})$
$V_{IN, min}$	converter input voltage
$\eta_{i, min}$	converter minimum efficiency, i=1, 2,...

For applications requiring a filter current greater than 10 A, divide the converters into smaller groups and use multiple filters. Do not connect filters in parallel.

Figure 5 - F4810 – Typical Application

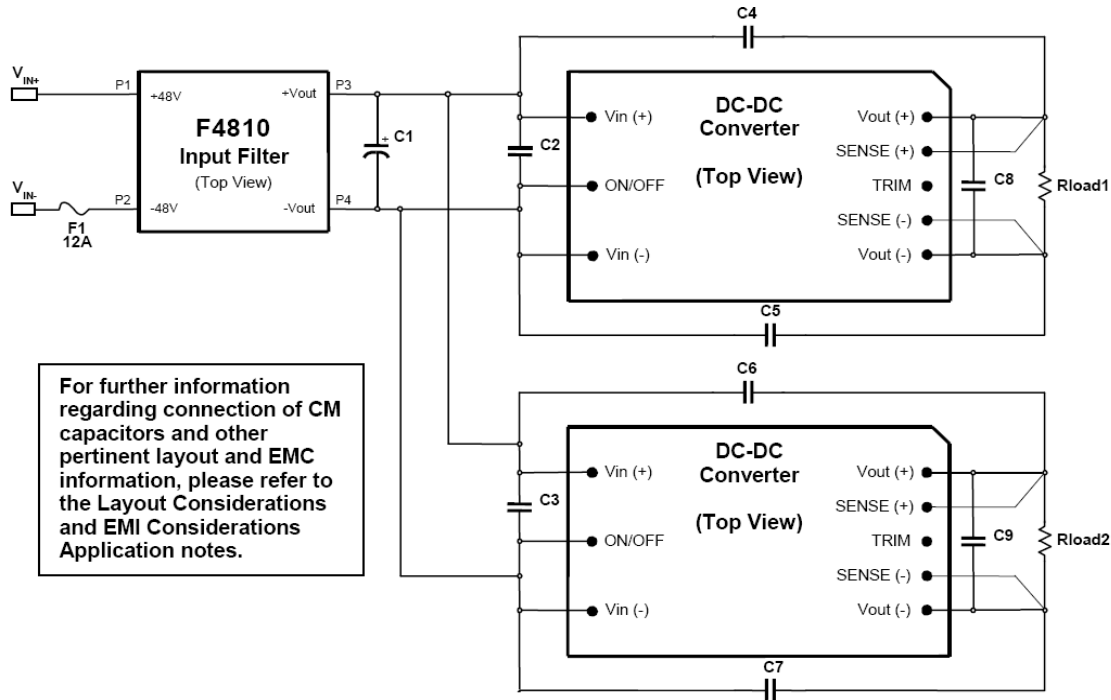

For further information regarding connection of CM capacitors and other pertinent layout and EMC information, please refer to the Layout Considerations and EMI Considerations Application notes.

For additional information regarding layout and EMC, refer to the Layout Considerations and EMI Considerations Application notes.

The following bulleted items are considerations regarding the external components for the typical application shown in Figure 5.

- Input electrolytic capacitor C1. We recommend 1-2 $\mu\text{F}/\text{W}$ for 48 V applications, and 2-4 $\mu\text{F}/\text{W}$ for 24 V applications. This capacitor is needed to ensure stability of converters in presence of their negative input impedance characteristic. Note that electrolytic capacitors at $-40\text{ }^\circ\text{C}$ have 3-5 times less capacitance than at room temperature, and therefore it is good practice to check the power system at worst case conditions from this point of view, i.e. lowest ambient temperature, minimum input voltage, and maximum load. If electrolytic capacitors are restricted for use in the system, please contact the factory.
- Input capacitors C2, C3 are optional; they decrease input ripple current and improve EMI. One or two of the following ceramic chip capacitors, as required, per converter are recommended:
 - TDK C4532X7R2A105, 1.0 μF , 100 V – for 48 V applications
 - TDK C4532X7R1H475, 4.7 μF , 50 V – for 24 V applications

- Common-mode capacitor (Y-cap) values and their EMI attenuation effects depend on system grounding and layout (they are not shown on Figure 5). In EMI testing with the filter, ceramic capacitors between input and output of the converter (C4 – C7) were very helpful. Typical values for the capacitor between Vin- and Vout- are 3,300 pF – 5,100 pF, and for the capacitor between Vin+ and Vout+, 0 to 3,300 pF.

If connection of capacitors between input and output is prohibited because of system restrictions, connect Y-capacitors only from each input pin to system ground. The value of these capacitors in this case is “the bigger the better” (preferably 0.1 μF or larger). Voltage rating of Y-capacitors depends on the system isolation and safety requirements.

- Output capacitors C8, C9 are optional to reduce output ripple. Addition of one-two 47 μF ceramic capacitors, for example, for low voltage applications 3.3 V and below, significantly decreases output ripple from 25-40 mV peak-to-peak to 5-10 mV. Recommended capacitor for these low voltage applications is C3225X5R0J476 from TDK.
- UL testing was performed with a 12 Amps fuse (R451012 from Littelfuse). Fuses larger than 12 Amps should not be used. Smaller value fuses can be used as required for protection to a lower power limit.

3 PHYSICAL INFORMATION

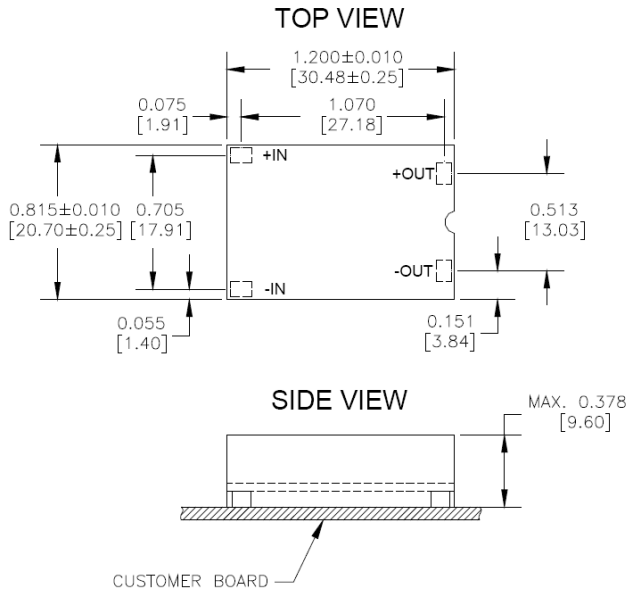

PAD/PIN CONNECTIONS	
PAD/PIN #	FUNCTION
+IN	Vin (+)
-IN	Vin (-)
-OUT	Vout (-)
+OUT	Vout (+)

- All dimensions are in inches [mm]
- Connector Material: Copper
- Connector Finish: Gold over Nickel
- Converter Weight: 0.34 oz [9.5 g]
- Recommended Surface-Mount Pads: Min. 0.080" x 0.112" [2.03 x 2.84]

4 FILTER PART NUMBERING ORDERING INFORMATION

PRODUCT SERIES	INPUT VOLTAGE	RATED LOAD CURRENT	TAPE AND REEL	ENVIRONMENTAL
F	24	10	- R	G
Filter Module	48: 80 V 24: 45 V	10 A	No letter ⇒ Bulk R ⇒ Tape and Reel	G ⇒ RoHS compliant for all six substances

The example above describes P/N F2410-R: 0-45 V input, 10 A output current, tape and reel, and Eutectic Tin/Lead solder. Please consult factory for the complete list of available options and G option RoHS.

F & FC Series Input Filters

FC Series, 0-100 VDC, 5/10/20 A, THT



The FC series EMI filters are accessories to the Bel Power Solutions line of DC-DC power converters. They are intended to be used in series with the inputs to the converters, between the source and the converter (with its necessary external input capacitor). A properly-sized filter can serve for multiple converters.

There are three sizes of FC filters, differentiated by their DC current ratings. They are all rated for up to 100 VDC continuous, and for 1500 VDC test voltage from input (or output) to ground. The three DC current ratings are 5.0A, 10A, and 20A through current.

Each filter provides both normal mode and common mode attenuation in normal application.

Features

- Meets Class B conducted limits
- Optimized for Bel Power Solutions' high density, board-mounted products
- PCB mountable
- Common mode and differential mode filtering
- Industry-standard pinout
- -40 °C to 80 °C case operation
- >30 dB insertion loss at 500 kHz
- 100 VDC operation
- 1500 V isolation
- Approved to the latest revision of safety standards: UL/CSA60950-1

Viewing this Document:

The figures and graphs in this section may be difficult to read with normal resolution video displays. For improved legibility, print this section.

Notes:

MTBF predictions may vary slightly from model to model.

Specifications typically at 25 °C, normal line, and full load, unless otherwise stated.

Soldering conditions: I/O pins, 260 °C, 10 seconds; fully compatible with commercial wave-soldering equipment.

1 MODEL SELECTION

There are presently three models in the FC Series, all rated for zero to up to 100 VDC input voltage. They differ by current capability. In general, the higher current filters offer higher attenuation than the lower current models.

Table 1 - FC Filter Series Models

MODEL	OPERATING CURRENT Amps	INSERTION LOSS ⁵ DIFFERENTIAL MODE (dB)	INSERTION LOSS ¹ COMMON MODE (dB)	TYPICAL RESISTANCE ⁶ (MOHMS)
FC100V5A-G	5	28	30	27
FC100V10A-G	10	31	28	17
FC100V20A-G	20	26	32	6.6

2 FC MODEL NUMBERING CONVENTION

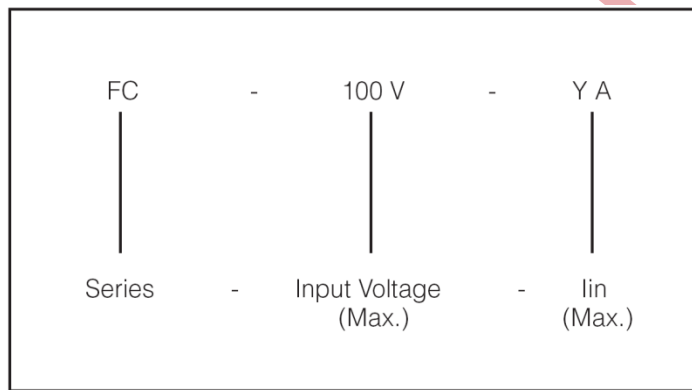

Custom models with alternate input voltages, or input current range, or different physical constructions are available. Consult the Bel Power Solutions factory.

3 DESIGN CONSIDERATIONS

Switching Power Converter modules, because they are essentially constant efficiency over the input voltage range, must be connected to a low AC impedance source of DC voltage.

A constant efficiency power module exhibits an input voltage versus current characteristic which electrically resembles a negative resistor in the normal operating range of the module. Constant efficiency means that if the output power is held constant, the input power will remain constant across the operating input voltage range. If the source voltage rises, the current drawn from the source will fall, to maintain a constant product of voltage and current, hence, constant input power. This characteristic is that of a negative resistor. When a negative resistance is fed from a positive source impedance which has a greater magnitude than that of the negative resistance, either the system crashes or it becomes unstable. A good general rule is that the magnitude of the source impedance must be lower than the magnitude of the input impedance of the module, at all frequencies up to the switching frequency of the module. (The classic reference is Middlebrook and Cuk, "Input Filter Considerations in Design and Application of Switching Regulators," Advances in Switched-Mode Power Conversion, pp 91-107, TeslaCo, 1981.) This rule is especially important, and harder to follow, with higher power modules because the magnitude of the negative input impedance is lower.

The normal solution is to place a low impedance capacitor directly across the input terminals of the module. 100 to 220 μ F is usually recommended for output power levels up to 300 Watts. This capacitor insures that the magnitude of the source impedance is lower than that of the module input impedance. Note: this assumes that the DC source resistance is

⁵ Typical loss at 500 kHz (50 Ohms)

⁶ Resistance per leg

sufficiently low; nothing can correct this problem. Too high a DC source resistance means that the necessary energy required by the input of the module is not available, and this system will not work.

Use of the capacitor complicates the system design. There must be some consideration of the surge current required to charge the capacitor when power is first applied. A surge limiting mechanism may be required. The capacitor may form a resonant circuit with the inductance of an EMI filter. If this happens, the resonance will require damping. The capacitor must be rated to handle all of the reflected ripple current of the module. Adding damping in the form of a resistor in series with the capacitor may reduce the ripple current in the capacitor. A small value, high ripple current capacitor may then be required in parallel with the damped electrolytic in order to meet the EMI requirements. The system designer must evaluate all of these requirements and make the correct choices for the application.

Figure 1 - Application of Input Filters

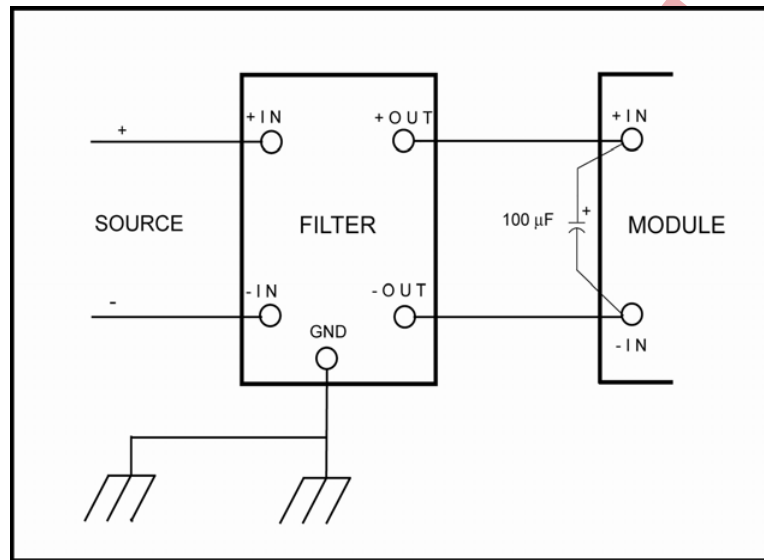

3.1 DC CURRENT RATINGS

FC filters are rated for 5.0, 10.0, and 20.0 amperes DC at up to +60 °C. Ambient temperature with 400 LFM of forced air across the module surface, or with the case temperature otherwise held to a maximum of +100 °C. With no forced air and no additional cooling, the same modules are rated for 3.5, 6.5, and 13 amperes maximum.

4 SAFETY CONSIDERATIONS

4.1 ISOLATION

The FC Series EMI filters have 1500 Volt DC isolation from input or output to ground, but no isolation from input to output. The output voltage is the input voltage.

4.2 FUSING

These filters have no external fuse. An external fuse must always be employed. In general, a 250 volt rated fuse must be used to meet international safety requirements. The fuse value should be selected to be greater than the maximum input current of the filter, which occurs at the minimum input voltage of the modules being powered through the filter. Both input traces and the chassis ground trace (if used) must be capable of conducting a current of 1.5 times the value of the fuse without opening. If one of the input lines is connected to chassis ground, then the fuse must be in the other input line.

4.3 CASE GROUNDING

The FC Series filters have a non-metallic case. It cannot be grounded. Each filter has a ground pin which must be connected, with as low an impedance as possible, to chassis ground in order for the filter to function properly.

5 INPUT SHUTDOWN PIN

Many DC-DC converter modules have an input “shutdown”, or “control” or “ON/OFF” pin. In most cases, the reference or return for this pin is the negative input pin of the module. When using such a system with an EMI filter module, the shutdown return must be made directly to the pin of the module, which is the output of the filter, and not at the input of the filter. This requires either an optical coupler or a relay, or other fully isolated device to control the module. There must not be any path for DC current to bypass the module, or its filtering characteristics will be severely compromised.

In order to operate without the internal common mode inductors magnetically saturating, the positive leg and negative leg currents in the filter must exactly equal. Even a small imbalance, as small as 10 ma, can create saturation of the inductors. When this happens, they no longer function as filter elements.

Figure 2 - Use of the Shutdown Pin with Input Filters

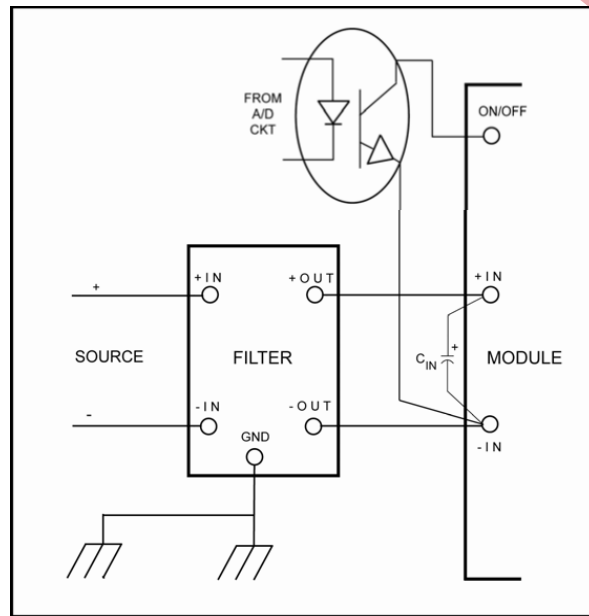

6 Reflected Input Current

The input reflected current can be reduced with the EMI filters. The amount of the reduction is determined by the quality of the capacitor across the input of the module. In most cases, this reduction will not be great at the switching frequency of the converter.

7 FC100V5A Module Details

Figure 3 - Filter Block Schematic

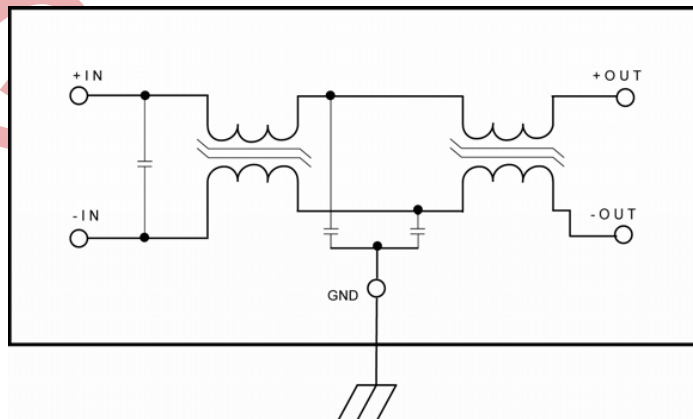
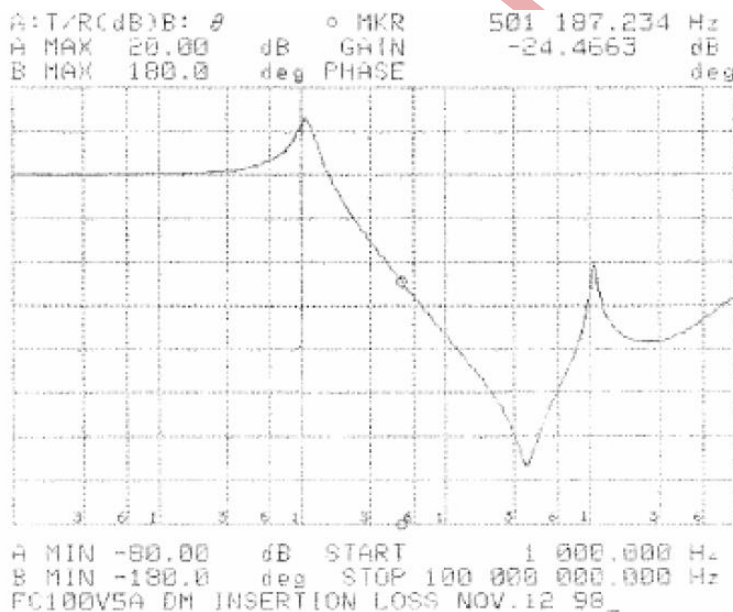

Table 2 - FC100V5A Specifications

FC100V5A Electrical Specifications EMI Filter						
PARAMETER	MIN	TYP	MAX	UNITS	CONDITIONS	NOTES
Input						
Input Voltage Range	0	48	100	V		All specifications typical at +25° C, nominal line, and full load unless otherwise noted. Specifications subject to change without notice.
Maximum average current			5	A	Ta = 60° C 400 lfm air	
			3.5	A	Ta = 60° C natural convection	
Frequency	0		60	Hz		
Typical Characteristics						
Resistance per leg		27		mΩ		
Common-mode insertion loss		30		dB		At 500 kHz, 50 Ohm circuit
Differential-mode insertion loss		28		dB		At 500 kHz, 50 Ohm circuit
Isolation voltage; Allows power module to meet FCC CISPR and EN55022 Class B conducted limits.		1500		VDC		
MTBF				Mhr	Consult Factory	(Bellcore TR-NWT-000332)
Environmental						
Case Operating Temperature	-40		+100	°C		
Storage Temperature Range	-40		+100	°C		
Operating & Storage Humidity			95	%	Non-Condensing	
Temperature Coefficient			0.03	%/°C		
Vibration			5	G	Three orthogonal axes; 5 minute test on each; 10 to 55 Hz	
Physical						
Case Dimensions	1.00 L	1.0 W	0.40 H	in		

Figure 4 - Differential Mode Attenuation Plot



Module: FC100V5A, five ampere EMI filter.
Instrument: Hewlett-Packard model 4194A
Start Freq: 1.0 kHz.
Stop Frequency: 100 MHz.
Scale: 10 dB per division.
System: 50 Ω in and 50 Ω out.

Figure 5 - Common Mode Attenuation Plot

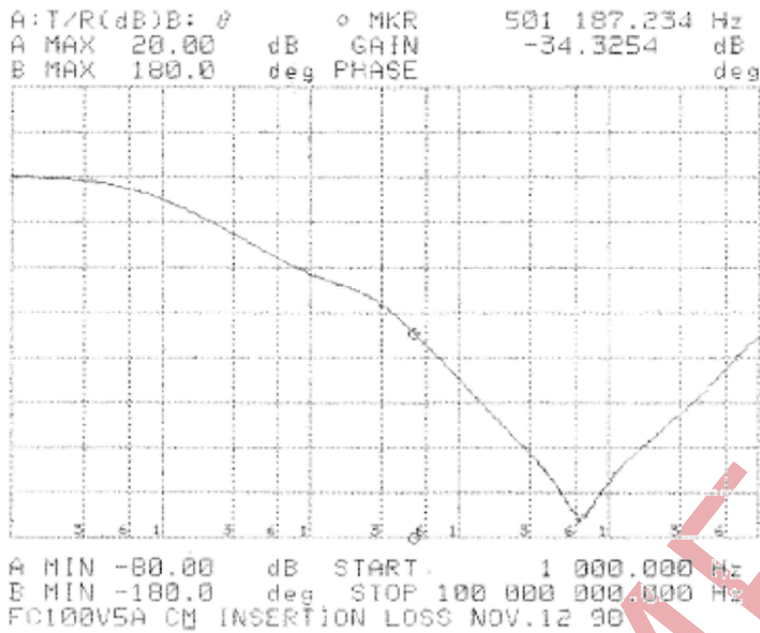

Module: FC100V5A, five ampere EMI filter.
Instrument: Hewlett-Packard model 4194A
Start Freq: 1.0 kHz.
Stop Frequency: 100 MHz.
Scale: 10 dB per division.
System: 50 Ω in and 50 Ω out.

Figure 6 - Output Impedance Plot

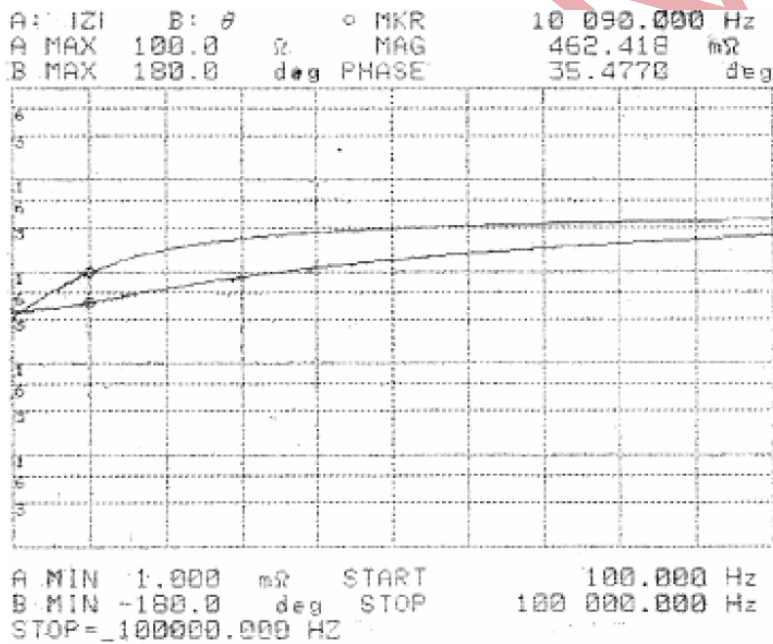

Module: FC100V5A, five ampere EMI filter.
Plot: Impedance of the module, looking into the output pins with the input pins short circuited.
Instrument: Hewlett-Packard model 4194A
Start Freq: 100 Hz.
Stop Frequency: 100 kHz.
Scale: Log: 1.0 m Ω to 100 Ω

Note: The dc resistance baseline is higher than actual because of fixture limitations. The DC resistance of the module is 56 m Ω .

8 FC100V10A MODULE DETAILS

Figure 7 - Filter Block Schematic

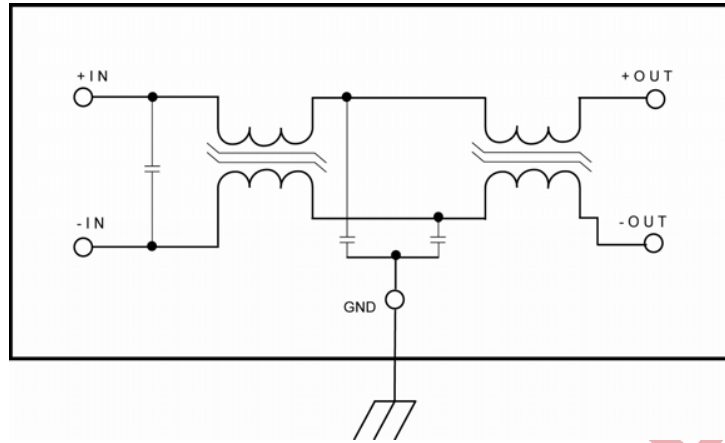
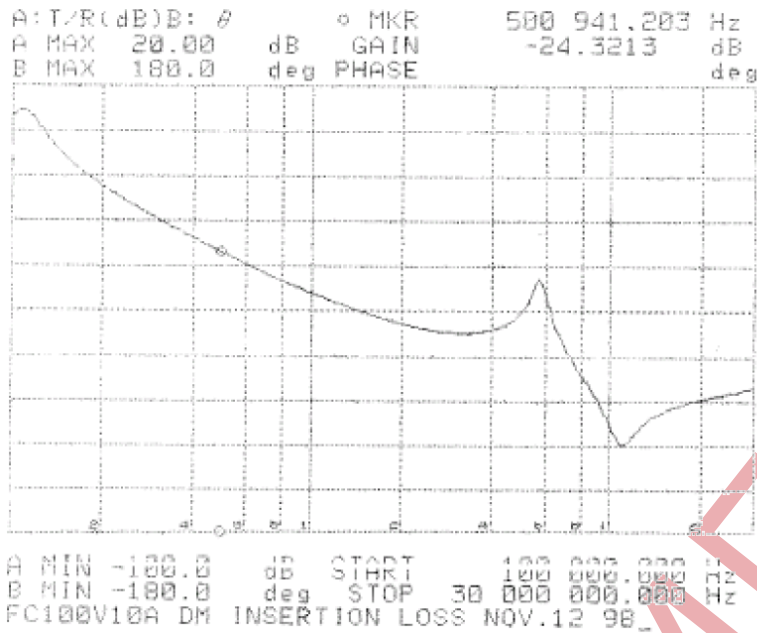

Table 3 - FC100V10A Specifications

FC100V10A Electrical Specifications EMI Filter						
PARAMETER	MIN	TYP	MAX	UNITS	CONDITIONS	NOTES
Input						
Input Voltage Range	0	48	100	V		All specifications typical at +25° C, nominal line, and full load unless otherwise noted. Specifications subject to change without notice.
Maximum average current			10	A	Ta = 60°C 400 lfm air	
			6.5	A	Ta = 60°C natural convection	
Frequency	0		60	Hz		
Typical Characteristics						
Resistance per leg		17		mΩ		
Common-mode insertion loss		28		dB		At 500 kHz, 50 Ohm circuit
Differential-mode insertion loss		31		dB		At 500 kHz, 50 Ohm circuit
Isolation voltage; Allows power module to meet FCC CISPR and EN55022 Class B conducted limits.		1500		VDC		
MTBF				Mhr	Consult Factory	(Bellcore TR-NWT-000332)
Environmental						
Case Operating Temperature	-40		+60	°C		
Storage Temperature Range	-40		+125	°C		
Operating & Storage Humidity			95	%	Non-Condensing	
Temperature Coefficient			0.03	%/°C		
Vibration			5	G	Three orthogonal axes; 5 minute test on each; 10 to 55 Hz	
Physical						
Case Dimensions	2.00 L	1.0 W	0.44 H	in		

Figure 8 - Differential Mode Attenuation Plot



Module: FC100V10A, ten ampere EMI filter.
Instrument: Hewlett-Packard model 4194A
Start Freq: 100 kHz.
Stop Frequency: 30 MHz.
Scale: 12 dB per division.
System: 50 Ω in and 50 Ω out.

Figure 9 - Common Mode Attenuation Plot



Module: FC100V10A, ten ampere EMI filter.
Instrument: Hewlett-Packard model 4194A
Start Freq: 100 kHz.
Stop Frequency: 30 MHz.
Scale: 10 dB per division.
System: 50 Ω in and 50 Ω out.

Figure 10 - Output Impedance Plot

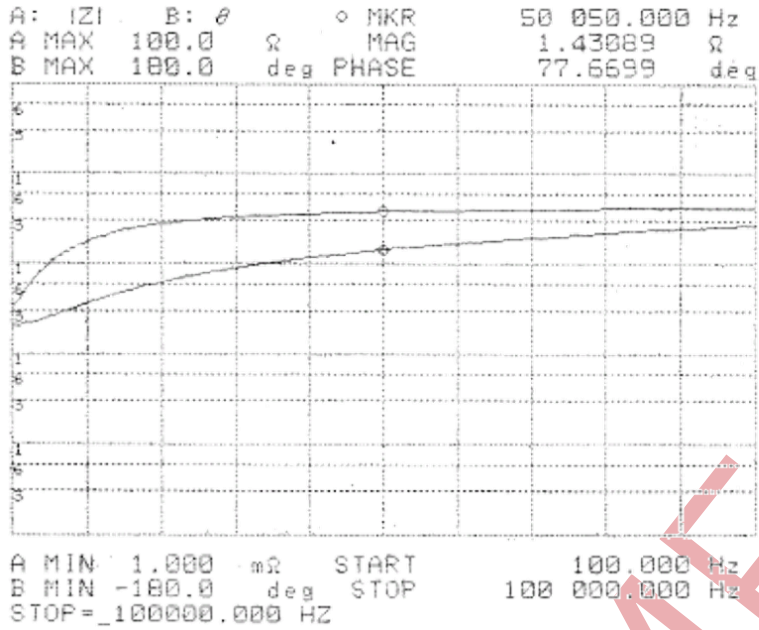

Module: FC100V10A, ten ampere EMI filter.
Plot: Impedance of the module, looking into the output pins with the input pins short circuited.
Instrument: Hewlett-Packard model 4194A
Start Freq: 100 Hz.
Stop Frequency: 100 kHz.
Scale: Log: 1.0 m Ω to 100 Ω .

Note: The DC resistance baseline is higher than actual because of fixture limitations. The DC resistance of the module is 32 m Ω .

9 FC100V20A MODULE DETAILS

Figure 11 - Filter Block Schematic

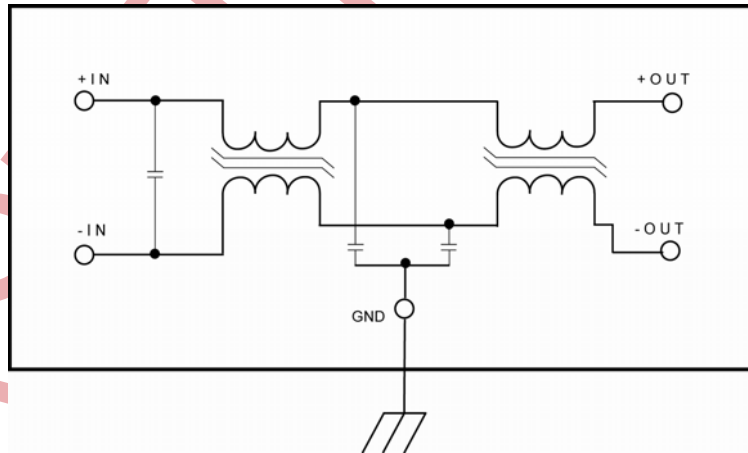

F & FC Series Input Filters

FC Series, 0-100 VDC, 5/10/20 A, THT

Table 4 - FC100V20A Specifications

FC100V20A Electrical Specifications EMI Filter						
PARAMETER	MIN	TYP	MAX	UNITS	CONDITIONS	NOTES
Input						
Input Voltage Range	0	48	100	V		All specifications typical at +25° C, nominal line, and full load unless otherwise noted. Specifications subject to change without notice.
Maximum average current			20	A	Ta = 60 °C 400 lfm air	
			13	A	Ta = 60 °C natural convection	
Frequency	0		60	Hz		
Typical Characteristics						
Resistance per leg		6.6		mΩ		
Common-mode insertion loss		32		dB		At 500 kHz, 50 Ohm circuit
Differential-mode insertion loss		26		dB		At 500 kHz, 50 Ohm circuit
Isolation voltage; Allows power module to meet FCC CISPR and EN55022 Class B conducted limits.		1500		VDC		
MTBF				Mhr	Consult Factory	(Bellcore TR-NWT-000332)
Environmental						
Case Operating Temperature	-40		+100	°C		
Storage Temperature Range	-40		+100	°C		
Operating & Storage Humidity			95	%	Non-Condensing	
Temperature Coefficient			0.03	%/°C		
Vibration			5	G	Three orthogonal axes; 5 minute test on each; 10 to 55 Hz	
Physical						
Case Dimensions	2.05 L	1.65 W	0.46 H	in		

Figure 12 - Differential Mode Attenuation Plot

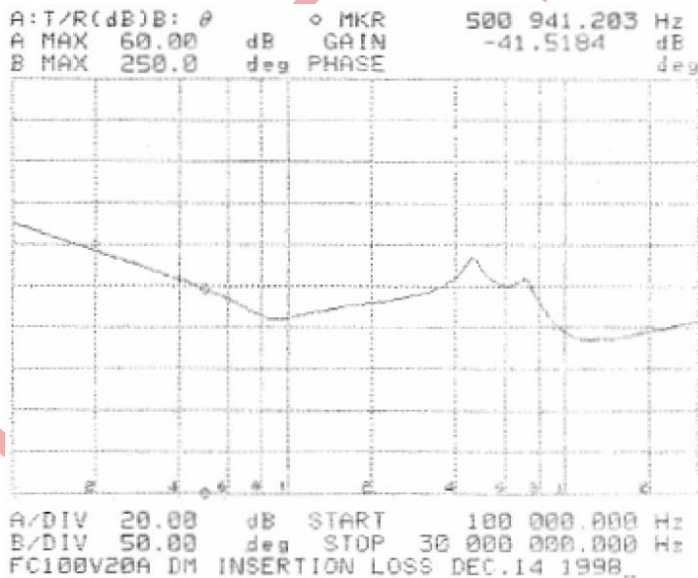

Module: FC100V20A, twenty ampere EMI filter.
Instrument: Hewlett-Packard model 4194A
Start Freq: 100 kHz.
Stop Frequency: 30 MHz.
Scale: 20 dB per division.
System: 50 Ω in and 50 Ω out.



Asia-Pacific
 +86 755 298 85888

Europe, Middle East
 +353 61 225 977

North America
 +1 408 785 5200

F & FC Series Input Filters

FC Series, 0-100 VDC, 5/10/20 A, THT

Figure 13 - Common Mode Attenuation Plot

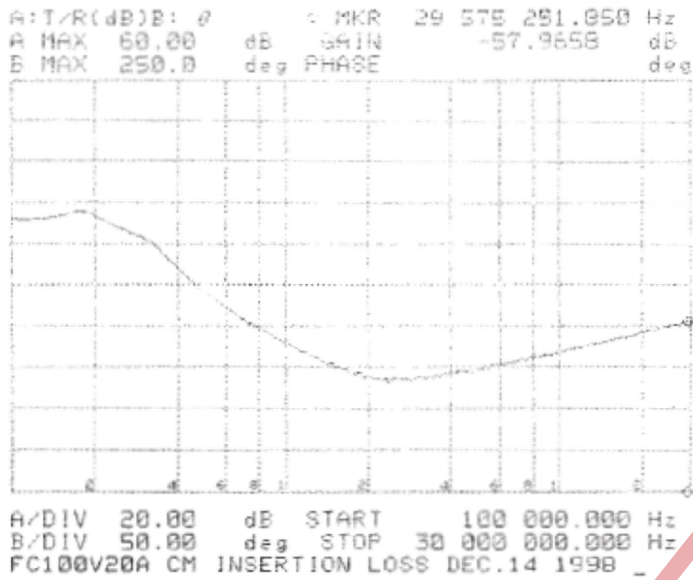

Module: FC100V20A, twenty ampere EMI filter.
Instrument: Hewlett-Packard model 4194A
Start Freq: 100 kHz.
Stop Frequency: 30 MHz.
Scale: 20 dB per division.
System: 50 Ω in and 50 Ω out.

FC Series, 0-100 VDC, 5/10/20 A, THT

Figure 14 - Output Impedance Plot

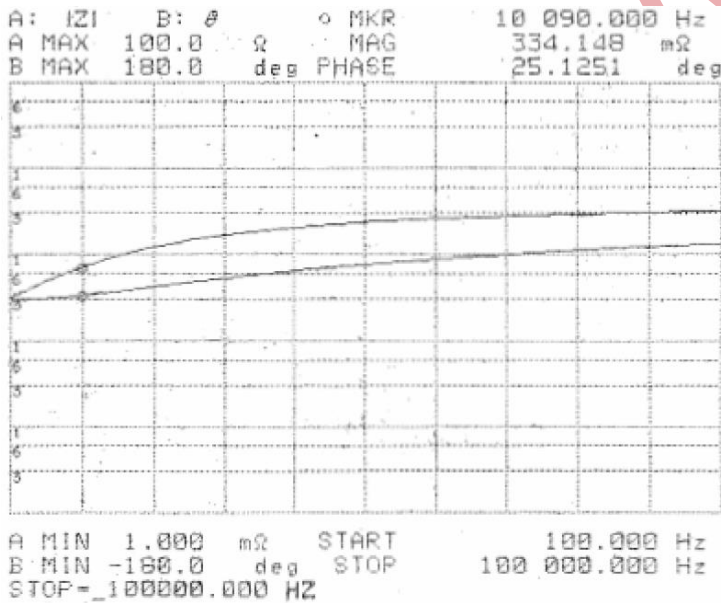

Module: FC100V20A, twenty ampere EMI filter.
Plot: Impedance of the module, looking into the output pins with the input pins short circuited.
Instrument: Hewlett-Packard model 4194A
Start Freq: 100 Hz.
Stop Frequency: 100 kHz.
Scale: Log: 1.0 m Ω to 100 Ω .

Note: The DC resistance baseline is higher than actual because of fixture limitations. The DC resistance of the module is 21 m Ω .

F & FC Series Input Filters

10 EMI MEASUREMENT METHODOLOGY

There are two methods of measurement for input conducted EMI: voltage measurements and current measurements. The voltage data presented uses a 50S LISN (Line Impedance Stabilization Network) and measures the input voltage spectrum from each input line of the converter to ground, using FCC and CISPR measurement techniques. The current data uses a 10 microfarad capacitor from each input line to ground, and measures the current in both lines simultaneously using the measurement technique defined in section 3.4.5, part B3 of the Bellcore document GR-1089-CORE. In each case, there was no external input filter. There was only an appropriate value capacitor across the input lines. The case of the unit under test was grounded to the reference ground plane, as was the output common of the unit. All spectra presented were taken with production grade modules, operating from 48 VDC at the full-rated output load current.

Figure 15 - Input Conducted EMI Voltage Test Circuit

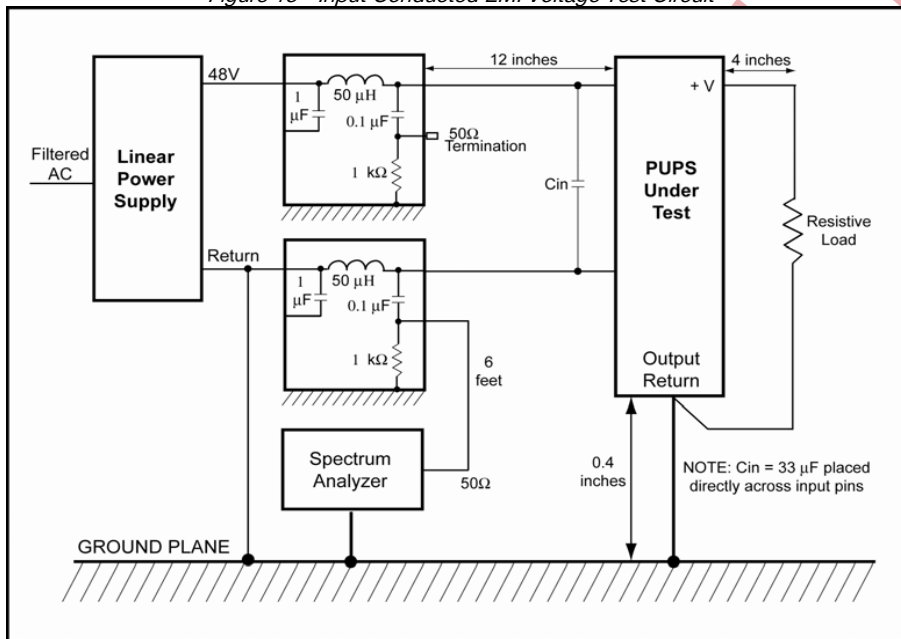
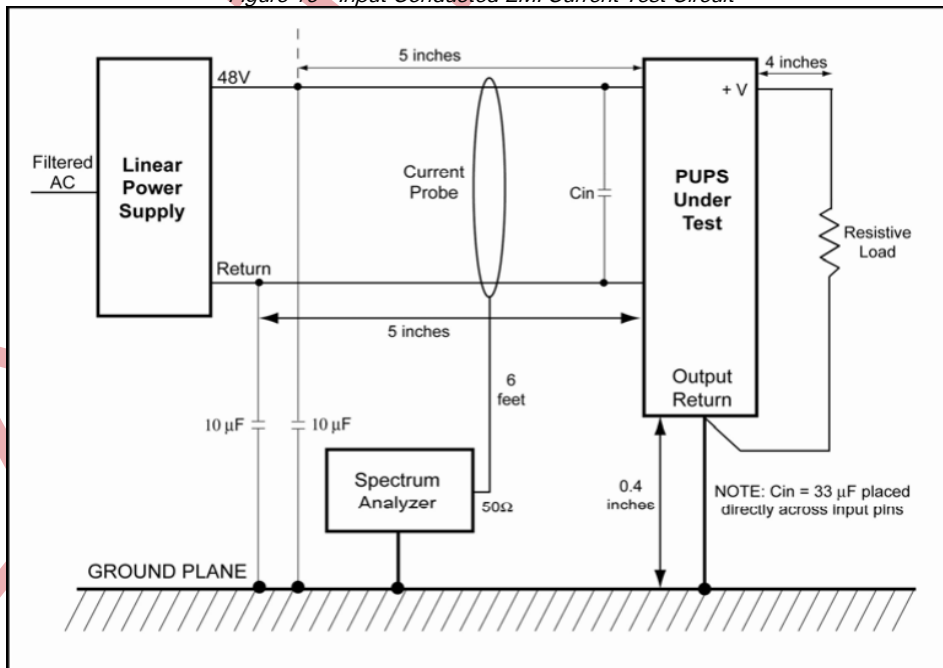
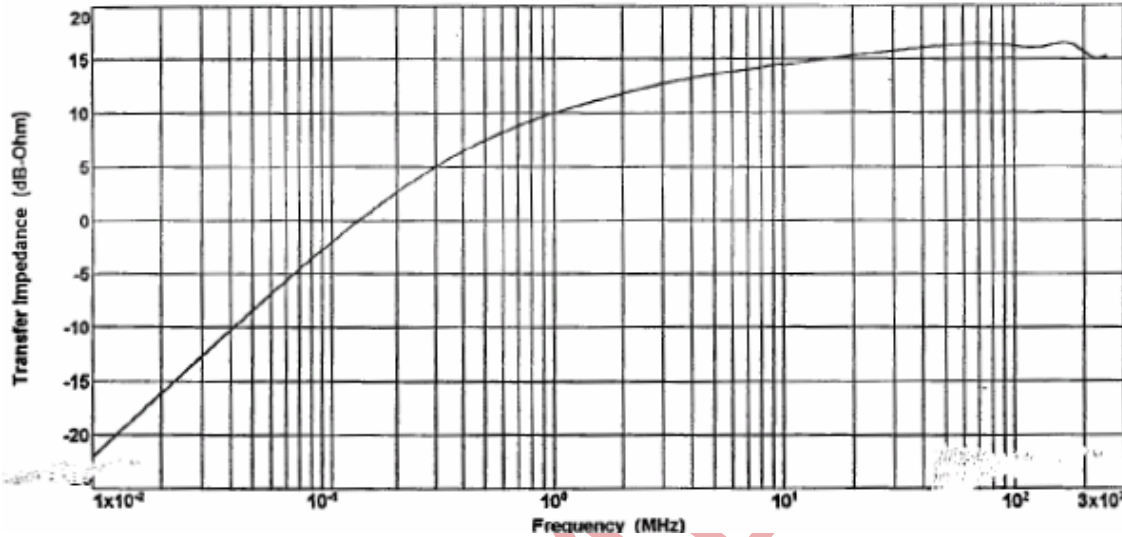

Figure 16 - Input Conducted EMI Current Test Circuit



An EMCO model 94430-1 current probe was used in this test circuit. The probe has a transfer impedance which is not constant with frequency. The transfer impedance, expressed in dBΩ, must be subtracted from the reading as measured on the spectrum analyzer in dBμV, in order to obtain the true current, measured in dBμA. Note that this is a common-mode current measurement, where both input lines to the unit under test are measured simultaneously.

Figure 17 - EMCO Model 94430-1 EMI Current Probe Transfer Impedance Curve



11 PRINTED CIRCUIT BOARD DESIGN

For optimum filtering, all shunt capacitors which are used in either the input or output circuits must be wired with "Four-Terminal" techniques. Traces enter the node of the capacitor on one side of its pad (surface mount or discrete) and depart from the other side. Capacitors are never "Tee'd" from other traces. The traces feeding the capacitors should be close together and parallel. Never leave large loops in input (or output) and return traces in the printed circuit board designs for power converters. Large loops form large antennas; large antennas create the most radiated EMI.

It is recommended that one layer of the board which carries the filter and converter(s) be dedicated as a ground plane. Preferably, this is the layer directly under the modules. It should extend out beyond the edges of the modules. The ground plane should be connected to earth ground, or to +Vin.

12 MANUFACTURING ISSUES

12.1 PROCESSING OF COMPLETED POWER MODULES

The incorporation of completed power modules into assemblies, or installation into mother boards, can be handled by the conventional industry methods. The stanchions which are fabricated of PPS plastic, along with all the other component parts used, will withstand normal preheat temperatures associated with standard soldering operations. The most common method for mass soldering of the power supply to a mother board is "wave soldering" and should be profiled approximately as follows:

1. The solder pot should be set at 500 °F and the conveyor should have a speed preset to insure that each section of the bottom side of the assembly dwells in the molten solder wave for 3 to 4 seconds. It is imperative that a correct temperature profile be used, not only to reduce solder defects but to eliminate any chance of thermal shock on the components.
2. The motherboard should attain a top side preheat temperature of 220° to 240° F before it enters the solder wave. The temperature change between the preheat and the soldering zones should be minimized.

The cooling rate after the solder wave should be similar in drop in temperature to the preheat rise.

12.2 NOTES ON PROCESSING OF COMPLETED POWER MODULES

- Bel Power Solutions through-hole pins are tin/lead plated and are easily soldered if all process parameters are met. However, in fluxing, the flux density, the activity and the ratio of flux foam to wave height must be closely monitored and controlled to maintain minimum solder defects.
- In controlling the solder profile, preheating of the assembly in two or three stages minimizes the thermal shock damage and increases the end life of the unit.
- If the power converters are to be hand soldered into the motherboard, a temperature controlled iron of 700° F (MAX) is recommended.
- While Bel Power Solutions power converters generally spend about 3 seconds in the wave, they are designed to withstand soldering temperatures of 500 °F for up to 10 seconds.
- If non-conventional methods are to be used to solder Bel Power Solutions power supplies to the motherboard, contact Bel Power Solutions Technical Support before proceeding.

13 MECHANICAL DRAWINGS

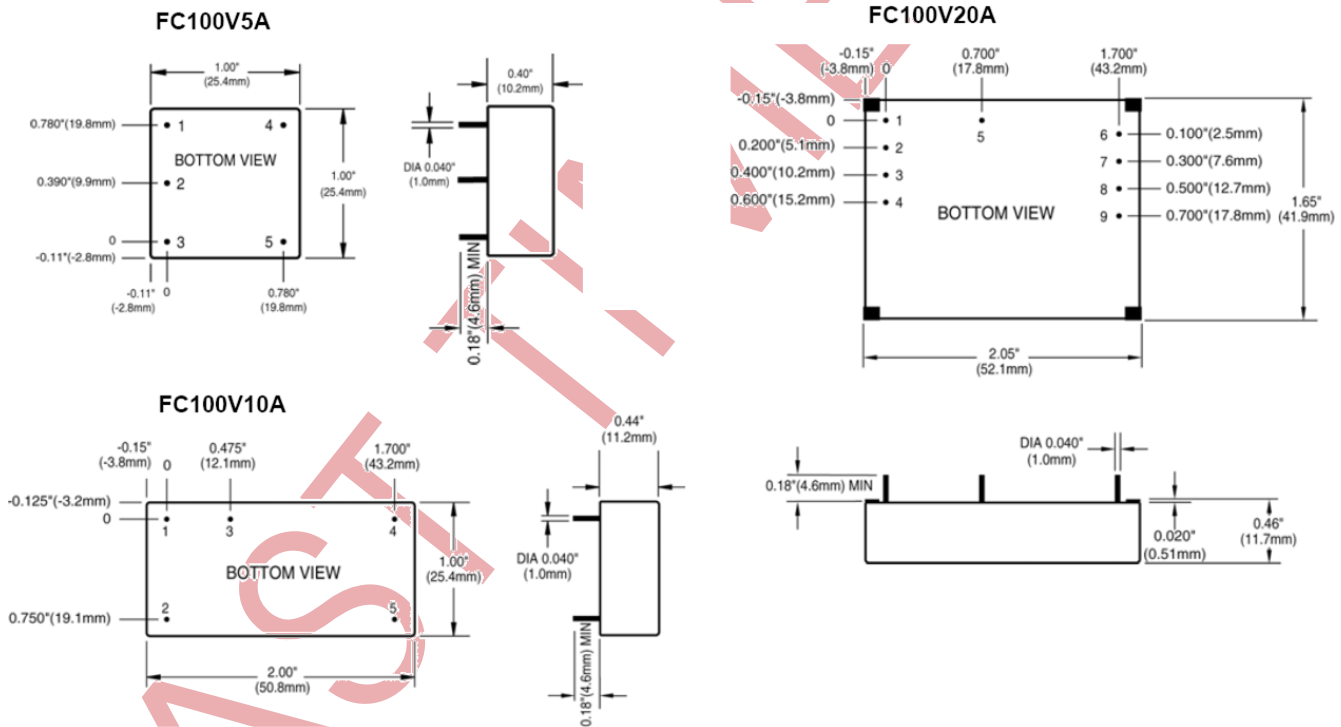

F & FC Series Input Filters

FC Series, 0-100 VDC, 5/10/20 A, THT

PIN	FUNCTION
5 A Module	
1	+Vin
2	Ground
3	-Vin
4	+Vout
5	-Vout

PIN	FUNCTION
10 A Module	
1	+Vin
2	-Vin
3	Ground
4	+Vout
5	-Vout

PIN	FUNCTION
20 A Module	
1	-Vin
2	-Vin
3	+Vin
4	+Vin
5	Ground
6	-Vout
7	-Vout
8	+Vout
9	+Vout

Tolerances

Inches: (Millimeters)

XX ± 0.020 X ± 0.5

XXX ± 0.010 XX ± 0.25

Pin: ± 0.002 ± 0.05

(Dimensions as listed unless otherwise specified.)

14 FC FILTERS ORDERING INFORMATION

DESCRIPTION	SUFFIX TO ADD TO PART NUMBER
RoHS compliant	Add a hyphen and then the letter "G" as the last character of the part number

Sample order code: FC100V5A-G represents an FC filter which has a 100 VDC input voltage rating, an operating current of 5 Amps, and the material set as well as the qualifications conform in all respects to the provisions Restrictions of Hazardous Substances (RoHS 2) EU Directive 2011/65/EU and any future amendments, addendums and decisions.

For more information on these products consult: tech.support@psbel.com

NUCLEAR AND MEDICAL APPLICATIONS - Products are not designed or intended for use as critical components in life support systems, equipment used in hazardous environments, or nuclear control systems.

TECHNICAL REVISIONS - The appearance of products, including safety agency certifications pictured on labels, may change depending on the date manufactured. Specifications are subject to change without notice.



Asia-Pacific
+86 755 298 85888

Europe, Middle East
+353 61 225 977

North America
+1 408 785 5200

X-ON Electronics

Largest Supplier of Electrical and Electronic Components

Click to view similar products for [Isolated DC/DC Converters](#) category:

Click to view products by [Bel Fuse](#) manufacturer:

Other Similar products are found below :

[ESM6D044440C05AAQ](#) [FMD15.24G](#) [PSL486-7LR](#) [Q48T30020-NBB0](#) [JAHW100Y1](#) [SPB05C-12](#) [SQ24S15033-PS0S](#) [18952](#) [19-130041](#)
[CE-1003](#) [CE-1004](#) [GQ2541-7R](#) [RDS180245](#) [MAU228](#) [J80-0041NL](#) [DFC15U48D15](#) [XGS-0512](#) [XGS-1205](#) [XGS-1212](#) [XGS-2412](#) [XGS-2415](#) [XKS-1215](#) [06322](#) [NCT1000N040R050B](#) [SPB05B-15](#) [SPB05C-15](#) [L-DA20](#) [DCG40-5G](#) [QME48T40033-PGB0](#) [XKS-2415](#) [XKS-2412](#)
[XKS-1212](#) [XKS-1205](#) [XKS-0515](#) [XKS-0505](#) [XGS-2405](#) [XGS-1215](#) [XGS-0515](#) [PS9Z-6RM4](#) [73-551-5038I](#) [AK1601-9RT](#) [VI-N61-CM](#) [VI-R5022-EXWW](#) [PSC128-7iR](#) [RPS8-350ATX-XE](#) [DAS1004812](#) [PQA30-D24-S24-DH](#) [VI-M5F-CQ](#) [VI-LN2-EW](#) [VI-PJW01-CZY](#)