

THE INFORMATION CONTAINED HEREIN IS CONSIDERED "PROPRIETARY" TO BEL FUSE INC. AND SHALL NOT BE COPIED, REPRODUCED OR DISCLOSED WITHOUT THE WRITTEN APPROVAL OF BEL FUSE INC.

RoHS



LED1 POLARITY			LED2 POLARITY		
PIN 13	PIN 14	COLOR	PIN 15	PIN 16	COLOR
-	+	GREEN	-	+	GREEN

**ELECTRICAL CHARACTERISTICS @ 25°C**

**URNS RATIO**

TP1	1CT : 1CT ±2%
TP2	1CT : 1CT ±2%
TP3	1CT : 1CT ±2%
TP4	1CT : 1CT ±2%

□CL @ 100kHz/100mVRMS (0-70 Deg. C)  
8mA DC BIAS 350µH MIN.

**INS. LOSS**

0.1MHz TO 1MHz	-1.1 dB MAX
1MHz TO 65MHz	-0.5 dB MAX
65MHz TO 100MHz	-0.8 dB MAX
100MHz TO 125MHz	-1.2 dB MAX

**RET. LOSS (MIN) @ 100 OHMS +/-15%**

0.5MHz-40MHz	-18 dB
40MHz-100MHz	-12+20LOG(f/80MHz) dB

**CM TO CM REJ**

100kHz - 100MHz -30 dB MIN

**CM TO DM REJ**

100kHz - 100MHz -35 dB MIN

HIPOT (Isolation Voltage): 1500 Vrms / 2250 VDC

100% OF PRODUCT TESTED IN PRODUCTION

**LED1 & LED2**

VF (FORWARD VOLTAGE) IF=20mA GREEN 2.2V TYP.

λD (DOMINANT WAVELENGTH) IF=20mA GREEN 570nm TYP.

OPERATING TEMPERATURE: 0°C TO 70°C

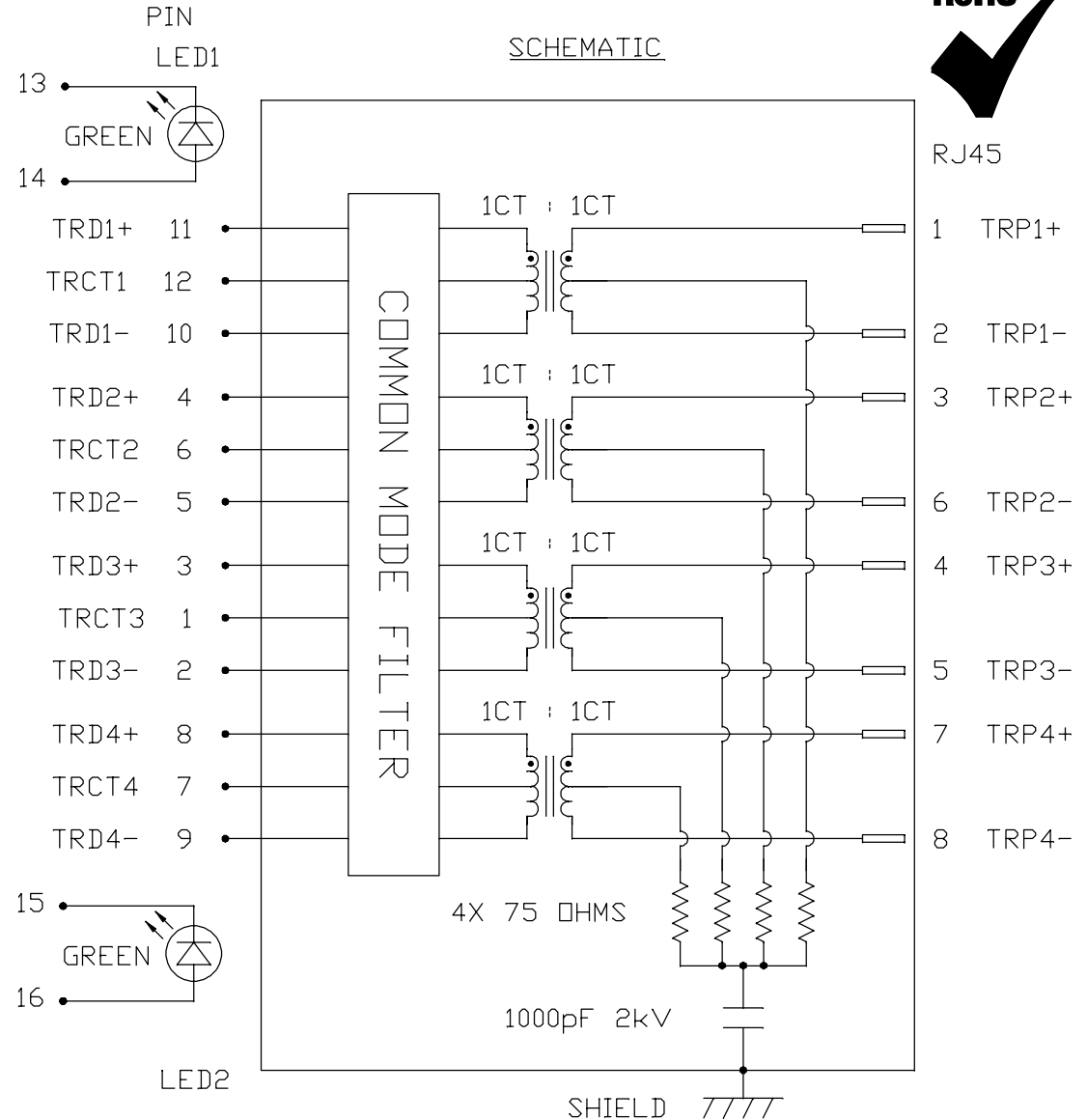

REV. : F PAGE : 2

ORIGINATED BY  
CHOW WANCHUNG  
DATE 2017-10-09

TITLE  
gigabit MagJack®  
(Ultra Low Profile)  
PATENTED

PART NO. / DRAWING NO.  
L829-1G1T-43

FILE NAME  
L829-1G1T-43\_F.DWG

STANDARD DIM. TOL. IN INCH	[ ] METRIC DIM. AS REF.
.X	UNIT : INCH [mm]
.XX	SCALE : N/A
.XXX	SIZE : A4



THE INFORMATION CONTAINED HEREIN IS CONSIDERED "PROPRIETARY" TO BEL FUSE INC. AND SHALL NOT BE COPIED, REPRODUCED OR DISCLOSED WITHOUT THE WRITTEN APPROVAL OF BEL FUSE INC.

MECHANICAL SPECIFICATION

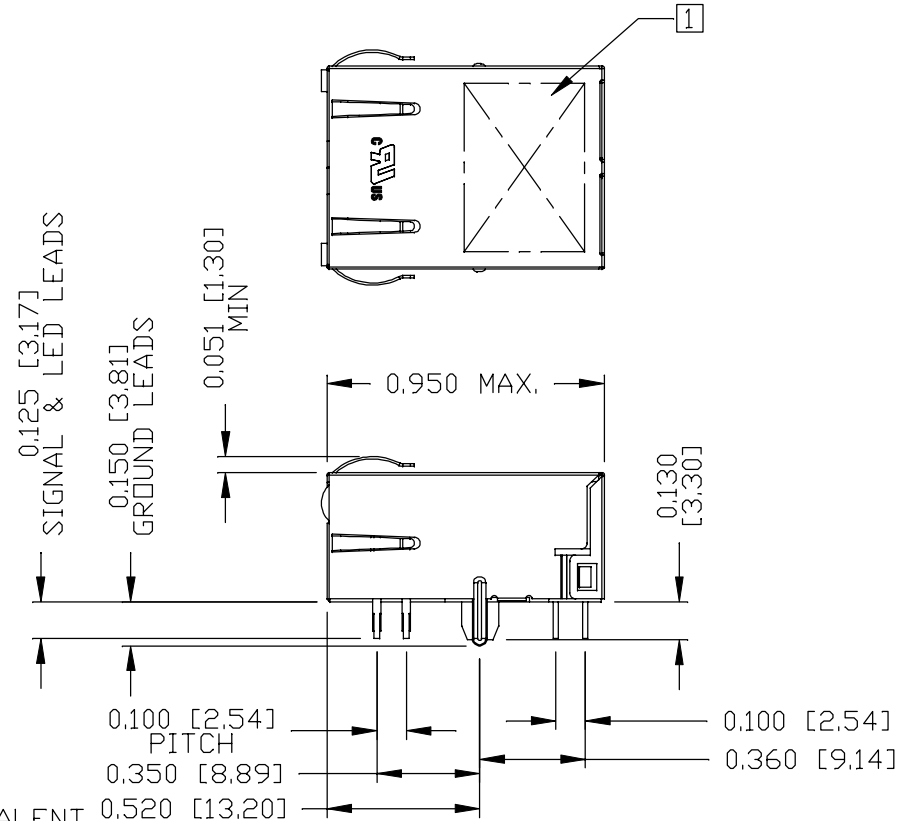
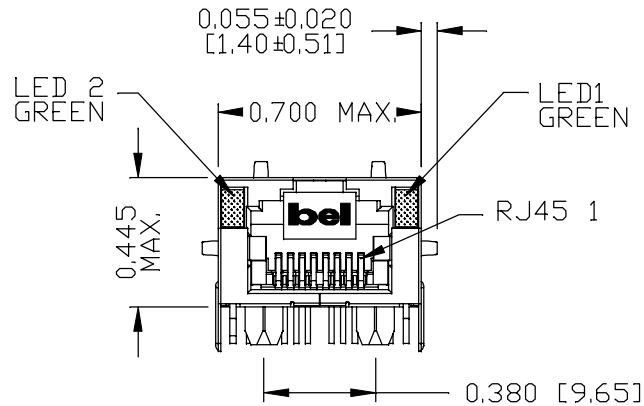

NOTES:

- PLASTIC HOUSING: THERMOPLASTIC PA, BLACK  
FLAMMABILITY RATING UL 94V-0
- CONTACTS: 30 MICRO-INCH HARD GOLD PLATING OR EQUIVALENT,
- OUTPUT PINS: TIN-COATED COPPER WIRE, DIA 0.018 INCH.  
100 MICRO-INCH MIN MATTE TIN.  
PINS ARE SOLDER DIPPED.
- METAL SHIELD: NICKEL PLATED ON COPPER ALLOY.  
(ALL GROUND LEADS ARE SOLDER DIPPED)

- 1. MARK PART WITH MFG. LOGO, MFG. NAME, PART NUMBER(L829-1G1T-43), AND DATE CODE AND PATENTED.
- 2. THE PRODUCT IS RoHS COMPLIANT.

- 3. THE PRODUCT IS PATENTED. THE PATENT NUMBER ARE U.S. PAT. 6,840,817 AND U.S. PAT. 7,123,117.
- 4. THE PART IS RECOMMENDED FOR WAVE SOLDERING. THE SUGGESTED PEAK WAVE SOLDERING CONDITION IS 260°C MAX AND 10 SECONDS MAX.

UL RECOGNIZED - FILE #E196366 AND E169987.

REV. : F      PAGE : 3

ORIGINATED BY ANTON LIAO DATE 2017-10-09	TITLE gigabit MagJack® (Ultra Low Profile) PATENTED	PART NO. / DRAWING NO. L829-1G1T-43	STANDARD DIM. TOL. IN INCH	[ ] METRIC DIM. AS REF.
		FILE NAME L829-1G1T-43_F.DWG	.X .XX .XXX	UNIT : INCH [mm] SCALE : N/A SIZE : A4



THE INFORMATION CONTAINED HEREIN IS CONSIDERED "PROPRIETARY" TO BEL FUSE INC. AND SHALL NOT BE COPIED, REPRODUCED OR DISCLOSED WITHOUT THE WRITTEN APPROVAL OF BEL FUSE INC.

RECOMMENDED PCB FOOTPRINT  
COMPONENT SIDE VIEW

RoHS

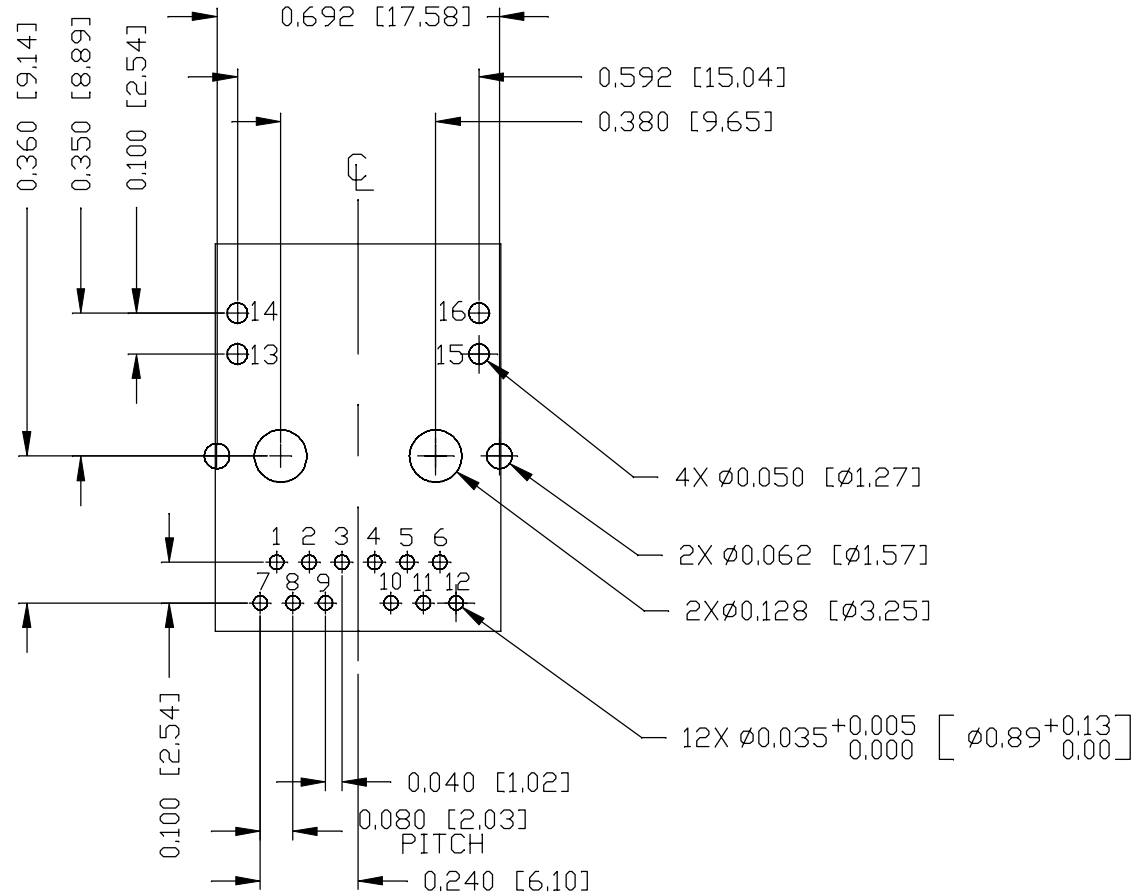

ORIGINATED BY  
ANTON LIAO  
DATE 2017-10-09  
DRAWN BY  
LI QUANKUN  
DATE 2017-10-09

TITLE  
gigabit MagJack®  
(Ultra Low Profile)  
PATENTED

PART NO. / DRAWING NO.  
L829-1G1T-43  
FILE NAME  
L829-1G1T-43\_F.DWG

STANDARD DIM. TOL. IN INCH	[ ] METRIC DIM. AS REF.
.X	UNIT : INCH [mm]
.XX	SCALE : N/A
.XXX ±0.004	SIZE : A4

REV. : F PAGE : 4



THE INFORMATION CONTAINED HEREIN IS CONSIDERED "PROPRIETARY" TO BEL FUSE INC. AND SHALL NOT BE COPIED, REPRODUCED OR DISCLOSED WITHOUT THE WRITTEN APPROVAL OF BEL FUSE INC.

RoHS



SUGGESTED PANEL OPENING

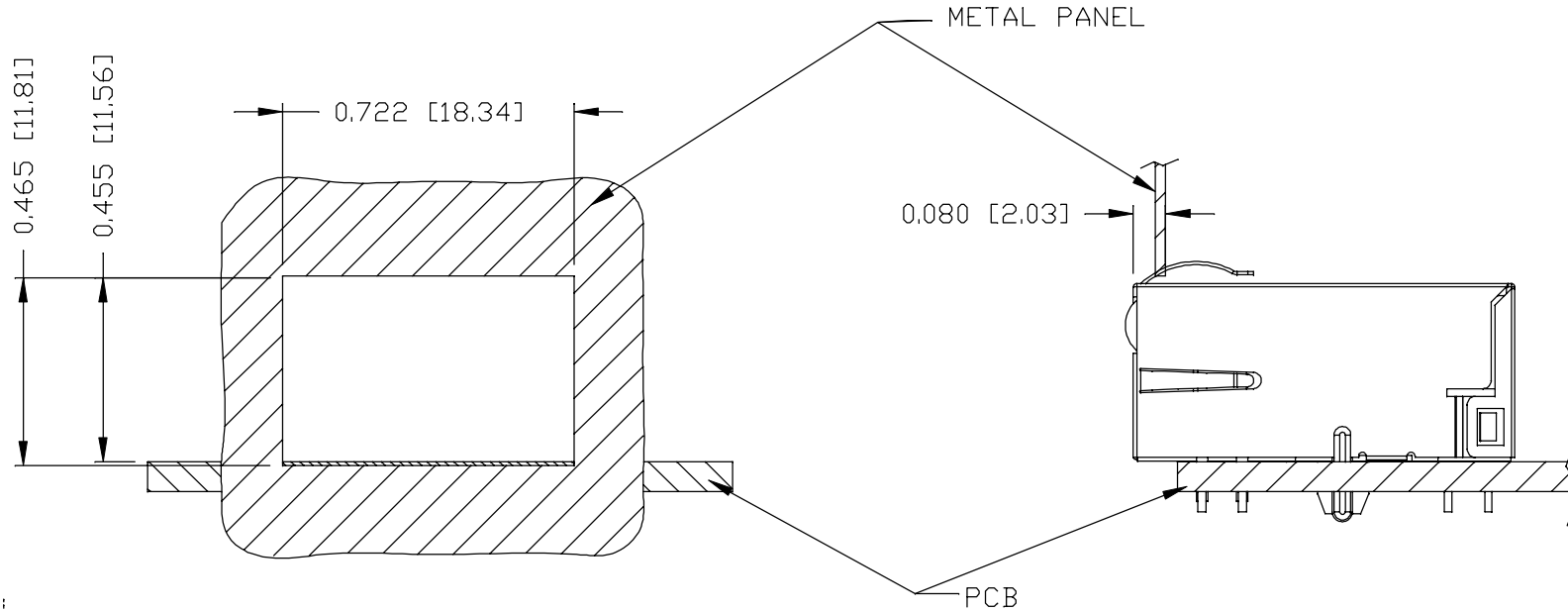

NOTE:

THE DISTANCE OF PANEL INSIDE SURFACE RELATIVE TO FRONT SURFACE OF PART IS ONLY A SUGGESTION. IN CASE THIS DISTANCE IS DIFFERENT, THE REQUIRED PANEL OPENING DIMENSIONS CHANGE ACCORDINGLY.

TRAY PACKING INFORMATION

PACKING TRAY : 0200-9999-E4 (TOP)  
0200-9999-E5 (BOTTOM)

PACKING QUANTITY : 60 PCS FINISHED GOODS PER TRAY  
11 TRAYS (660 PCS FINISHED GOODS) PER CARTON BOX

NOTE : CARDBOARDS ARE PLACED BETWEEN LAYERS OF PACKING TRAY INSIDE CARTON BOX  
(INCLUDE THE UPPERMOST AND LOWERMOST TRAY)

REV. :	F	PAGE :	5
--------	---	--------	---

ORIGINATED BY ANTON LIAO
DATE 2017-10-09
DRAWN BY LI QUANKUN
DATE 2017-10-09

TITLE gigabit MagJack® (Ultra Low Profile) PATENTED
--

PART NO. / DRAWING NO. L829-1G1T-43
FILE NAME L829-1G1T-43_F.DWG

STANDARD DIM. TOL. IN INCH	[ ] METRIC DIM. AS REF.
.X	UNIT : INCH [mm]
.XX	SCALE : N/A
.XXX ±0.004	SIZE : A4



THE INFORMATION CONTAINED HEREIN IS CONSIDERED "PROPRIETARY" TO BEL FUSE INC. AND SHALL NOT BE COPIED, REPRODUCED OR DISCLOSED WITHOUT THE WRITTEN APPROVAL OF BEL FUSE INC.

RoHS



TAPE AND REEL PACKING INFORMATION:

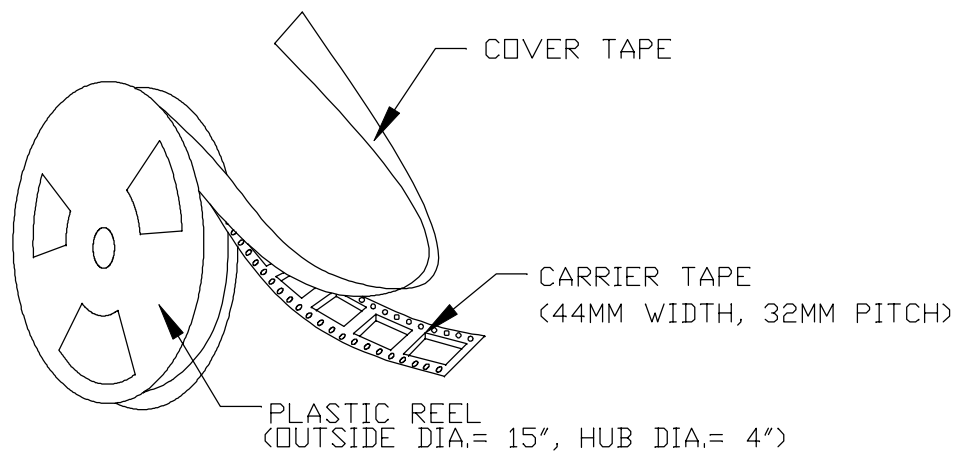

USER FEED DIRECTION

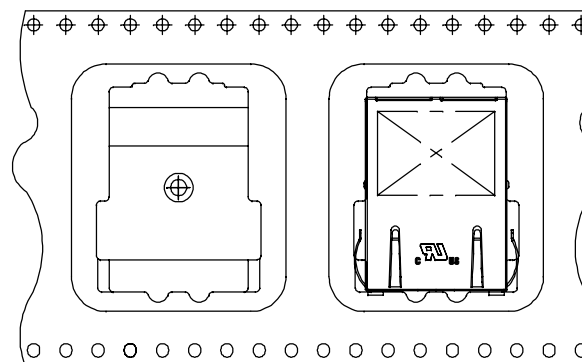
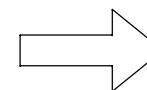

PART ORIENTATION & FEEDING DIRECTION.

NOTES:

- 1) LEAVES 48 INCHES COVER TAPE AND 10 EMPTY POCKETS AT TRAILER.
- 2) LEAVES 24 INCHES COVER TAPE AND 13 EMPTY POCKETS AT LEADER.
- 3) PACK 140 PCS PER REEL.
- 4) EACH PIZZA BOX CONTAINS ONE (1) REEL, ( 140 PCS FINISHED GOODS EACH PIZZA BOX ).
- 5) EACH OUTER CARTON CONTAINS SIX (6) PIZZA BOXES, ( 840 PCS FINISHED GOODS EACH OUTER CARTON ).

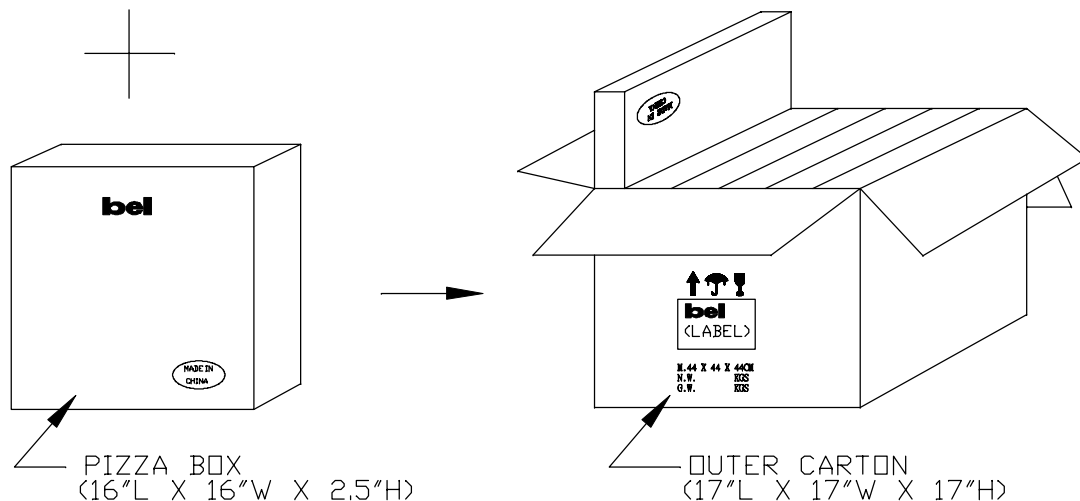

REV. : F PAGE : 6

ORIGINATED BY  
ANTON LIAO  
DATE 2017-10-19  
DRAWN BY  
LI QUANKUN  
DATE 2017-10-19

TITLE  
gigabit MagJack®  
(Ultra Low Profile)  
PATENTED

PART NO. / DRAWING NO.  
L829-1G1T-43  
FILE NAME  
L829-1G1T-43\_F.DWG

STANDARD DIM. TOL. IN INCH		[ ] METRIC DIM. AS REF.
.X		UNIT : INCH [mm]
.XX		SCALE : N/A
.XXX	±0.004	SIZE : A4



THE INFORMATION CONTAINED HEREIN IS CONSIDERED "PROPRIETARY" TO BEL FUSE INC. AND SHALL NOT BE COPIED, REPRODUCED OR DISCLOSED WITHOUT THE WRITTEN APPROVAL OF BEL FUSE INC.

DIMENSION CHART					
Ao	Bo	Ko	P1	So	LENGTH/22"REEL
0.713 [18.10]	0.965 [24.51]	0.657 [16.69]	1.260 [32.00]	1.591 [40.40]	11 METERS

FOR CARRIER TAPE

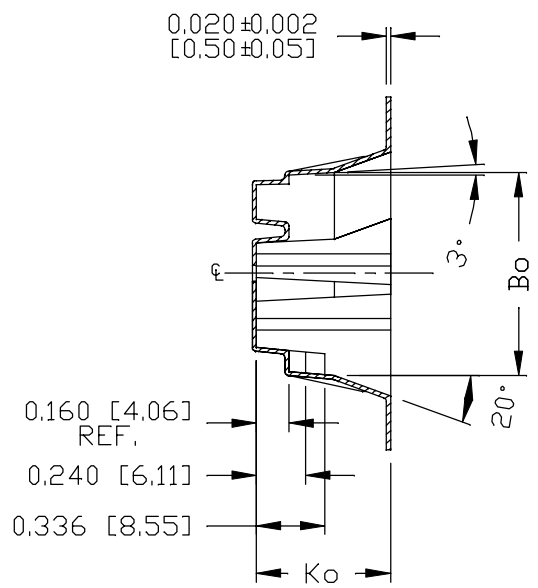

SECTION Y-Y

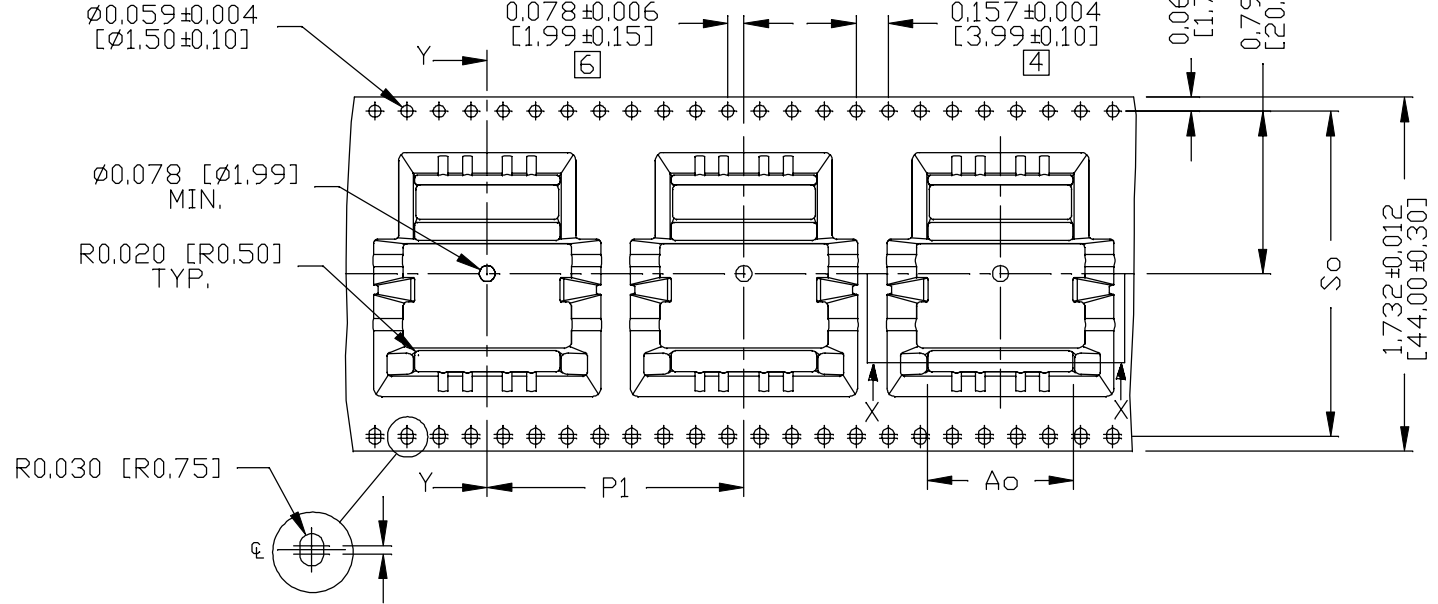
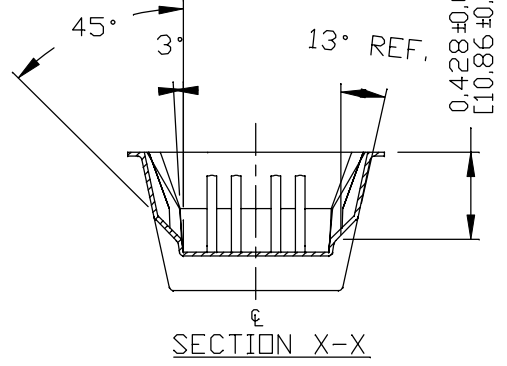

NOTES :

1. ALL OTHER SPECIFICATIONS SHOULD MEET EIA 481-2-A STANDARD.
2. CARRIER TAPE: N220-0405-09.

ORIGINATED BY  
ANTON LIAO  
DATE 2017-10-19

DRAWN BY  
LI QUANKUN  
DATE 2017-10-19

TITLE  
gigabit MagJack®  
(Ultra Low Profile)  
PATENTED

PART NO. / DRAWING NO.  
L829-1G1T-43

FILE NAME  
L829-1G1T-43\_F.DWG

STANDARD DIM. TOL. IN INCH	[ ] METRIC DIM. AS REF.
.X	UNIT : INCH [mm]
.XX	SCALE : N/A
.XXX ±0.004	SIZE : A4

REV. : F PAGE : 7



## X-ON Electronics

Largest Supplier of Electrical and Electronic Components

*Click to view similar products for [Modular Connectors / Ethernet Connectors](#) category:*

*Click to view products by [Bel Fuse](#) manufacturer:*

Other Similar products are found below :

[8949-H88/06BLKA/SN](#) [74441-0010/BKN](#) [MP1010RX-1000](#) [MP44RX-1000](#) [PHJ-4P4C-1-V-4](#) [PHP-6P6C-5](#) [GAX-3-66](#) [GAX-8-62](#) [GDCX-PA-66-50](#) [GDCX-PN-64](#) [GDCX-PN-66](#) [GDCX-PN-66-50](#) [GDLX-A-66](#) [GDLX-N-66](#) [GDLX-S-66](#) [GDLX-S-88K](#) [GDLX-SMT-S-88](#) [GDTX-S-88-50](#) [GDX-PA-1010](#) [GLX-N-1010M-BLK](#) [GLX-S-88M-BLK](#) [GMX-N-1010](#) [GMX-S-1010](#) [GMX-S-66](#) [GMX-SMT4-N-88](#) [GPX-2-64](#) [GSGX-N-2-88](#) [GSGX-N-4-88](#) [GSX-NS2-88-3.05](#) [GSX-NS2-88-3.05-50](#) [GSX-NS-88-3.05-50](#) [PT-108A-8C-UL](#) [PT-J951-8C](#) [PTS-J531-8CS-50UL](#) [1-1775629-2](#) [A-2014-0-4](#) [GWLX-S-88-GR](#) [GWLX-S9-88-YG](#) [DC-1021-8-WH-6](#) [1300530003](#) [1324640-4](#) [RJ11FTVC2G](#) [RJ11FTVC2N](#) [RJFTVX2SA1G](#) [132764-001](#) [1413235](#) [MP88X-1000](#) [MPS88RX-5000](#) [E5288-S000K3-L](#) [E5908-15A242-L](#)