

THE INFORMATION CONTAINED HEREIN IS CONSIDERED "PROPRIETARY" TO BEL FUSE INC. AND SHALL NOT BE COPIED, REPRODUCED OR DISCLOSED WITHOUT THE WRITTEN APPROVAL OF BEL FUSE INC.

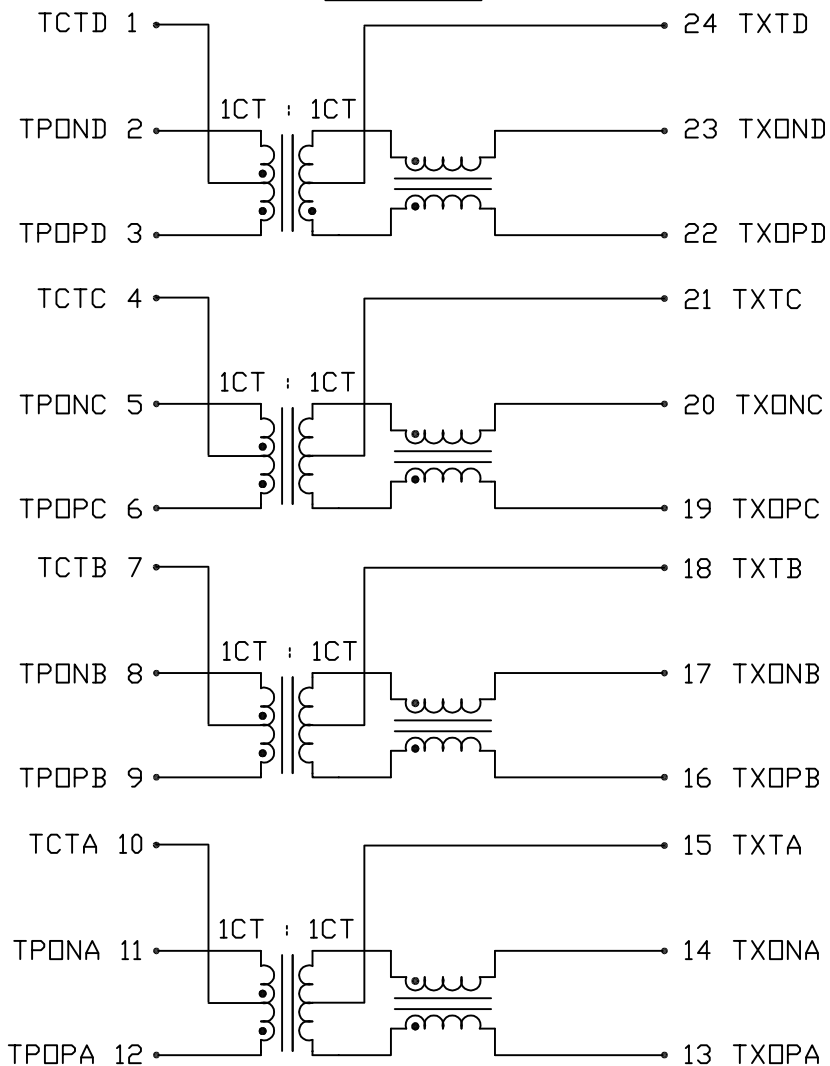

SCHEMATIC



ELECTRICAL CHARACTERISTICS @ 25°C

<p>URNS RATIO (3-1-2) : (22-24-23) 1CT : 1CT (6-4-5) : (19-21-20) 1CT : 1CT (9-7-8) : (16-18-17) 1CT : 1CT (12-10-11) : (13-15-14) 1CT : 1CT</p>	
<p>OCL -40°C TO +85°C</p>	<p>350μH MIN. AT 100kHz, 100mV WITH 8mA DC BIAS</p>
<p>INSERTION LOSS</p>	<p>1.1dB MAX. @ 0.1 TO 1MHz 0.5dB MAX. @ 1 TO 65MHz 1.0dB MAX. @ 80MHz 1.2dB MAX. @ 125MHz</p>
<p>RETURN LOSS UNDER 100 OHM ±15% ENVIRONMENT</p>	<p>18dB MIN. @ 0.5 TO 40 MHz 12-20LOG (f/80MHz) dB MIN. @ 40 TO 100MHz</p>
<p>COMMON TO COMMON REJECTION</p>	<p>30dB MIN. @ 0.1 TO 100MHz</p>
<p>CROSSTALK</p>	<p>33-20LOG (f/100MHz) dB MIN. @ 1 TO 100MHz</p>
<p>HIPOT</p>	<p>LEAKAGE CURRENT LESS THAN 1mA AT 1500VAC</p>

ORIGINATED BY	DATE
Alice Pang	2021-01-27
DRAWN BY	DATE
ZC Guo	2021-01-27

TITLE
ELECTRICAL SPECIFICATION
S558-5999-AR-F

PART NO. / DRAWING NO.
S558-5999-AR-F
FILE NAME
S5585999ARFA.DWG

STANDARD DIM.	[] METRIC DIM. AS REF.
TOL. IN INCH	UNIT : INCH [mm]
.X	SCALE : N/A
.XX	SIZE : A4
.XXX	

REV. : A	PAGE : 2

THE INFORMATION CONTAINED HEREIN IS CONSIDERED "PROPRIETARY" TO BEL FUSE INC. AND SHALL NOT BE COPIED, REPRODUCED OR DISCLOSED WITHOUT THE WRITTEN APPROVAL OF BEL FUSE INC.

SUGGESTED PCB PAD LAYOUT

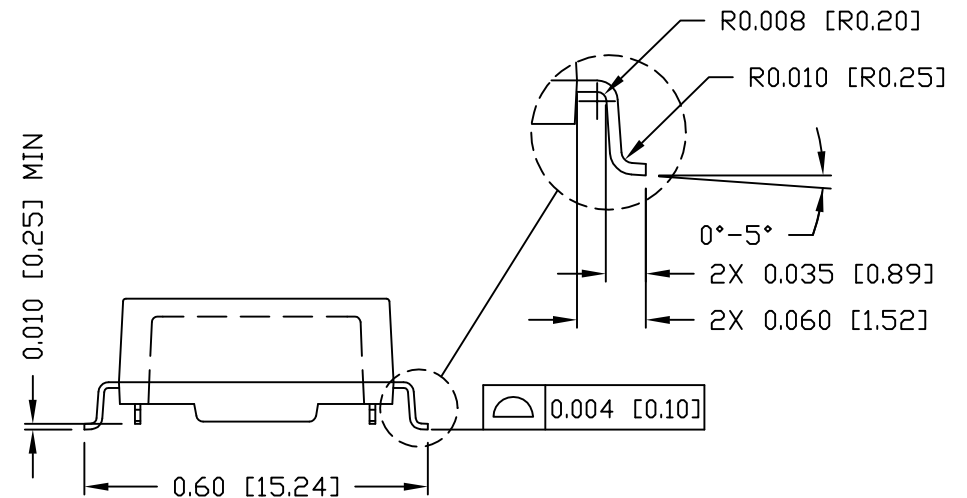
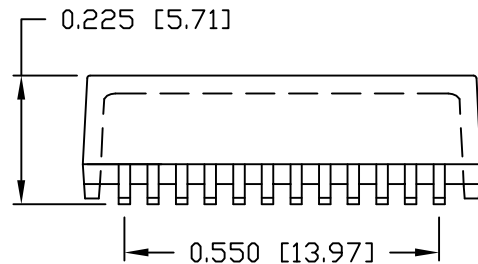
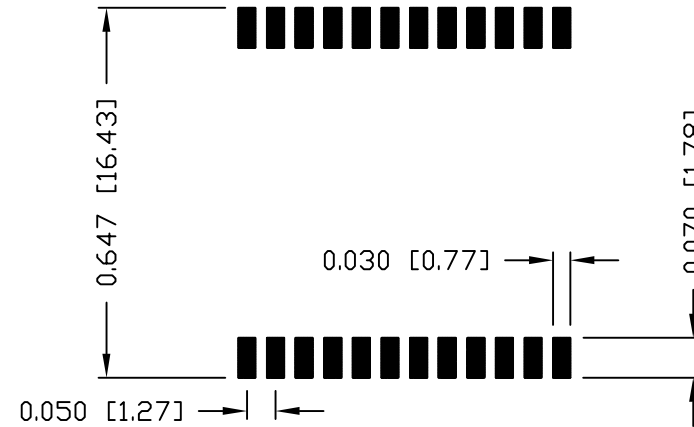
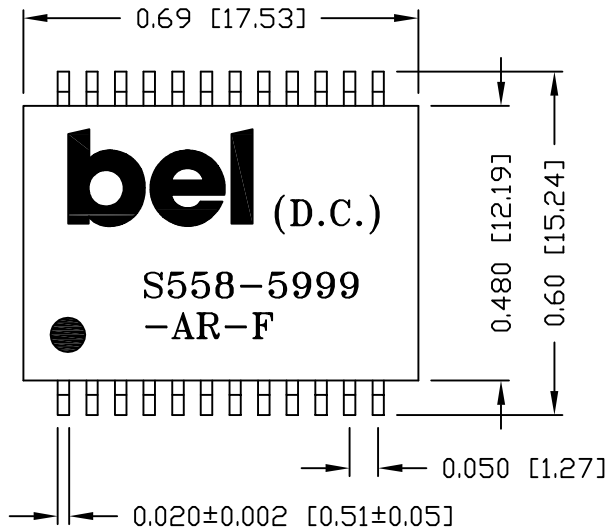

NOTES:

1. STANDARD MARKING REFER TO DOC. HAND-WORK-04.
2. PACKAGE CODE: "RQS001".

ORIGINATED BY	DATE
Lawrence Tsang	2021-01-27
DRAWN BY	DATE
ZC Guo	2021-01-27

TITLE
MECHANICAL DRAWING S558-5999-AR-F

PART NO. / DRAWING NO.
S558-5999-AR-F
FILE NAME
S5585999ARFA.DWG

STANDARD DIM.	[] METRIC DIM. AS REF.
TOL. IN INCH	
.X	
.XX	±0.01
.XXX	±0.005

UNIT : INCH [mm]
SCALE : N/A
SIZE : A4

REV. : A	PAGE : 3

X-ON Electronics

Largest Supplier of Electrical and Electronic Components

Click to view similar products for [Audio Transformers](#) / [Signal Transformers](#) category:

Click to view products by [Bel Fuse](#) manufacturer:

Other Similar products are found below :

[CU4S0506AT-2655-H1](#) [MGPWT-00449-P](#) [PE-64961](#) [1812WBT2-4](#) [BX1194WNL](#) [1879479-1](#) [PA1528ANL](#) [T1137NLT](#) [PE-65848FNLT](#)
[H5019EFNL](#) [CX2045ALNLT](#) [TG1G-E201NV6LF](#) [MGPWT-00059-P](#) [MGPWT-00266-P](#) [MGPWT-00278-P](#) [MGPWT-00431-P](#) [TTC-100](#)
[TTC-143-H](#) [TTC-5032-1](#) [4-1879391-0](#) [100213](#) [T1142NL](#) [TG1G-S001NZLF](#) [T1124NL](#) [1879732-1](#) [2-1879391-5](#) [MABA-010321-CT1A42](#)
[TX1341NL](#) [H0013FNL](#) [H5020FNL](#) [H2009FNLT](#) [H5004NLT](#) [S553-5999-52-F](#) [SCMS7D43AY100PT1](#) [T5008NLT](#) [PE-68517T](#) [MGPWT-](#)
[00339-P](#) [H5014FNLT](#) [TX1473NLT](#) [PE-69011NLT](#) [CX2043LNLT](#) [H7137FNLT](#) [H1259NLT](#) [TX1344NLT](#) [LM-LP-1005L](#) [H0013NLT](#)
[S558-5500-JV](#) [TX1193NLT](#) [T7015NL](#) [T1124NLT](#)