

SFP-1GBT-06

SFP Copper Transceiver 1000Base-T to GBIC

The Bel SFP-1GBT-06 transceiver is an internally configured 1000Base-T SFP module for GBIC host interface. The host interface transmits and receives serial data differentially at 1.25 Gbps. The copper interface is advertised as full duplex and will auto-negotiate to 10/100/1000 Base-T.

Key Features & Benefits

- Designed with Broadcom's BCM54616S chipset
- Complies with IEEE 802.3, 802.3u, and 802.3ab specifications
- Conforms to Multi-Source Agreement (MSA) specifications for SFP transceivers
- Supports IEEE 802.3u and IEEE 802.3ab auto-negotiation features to allow networking equipment to automatically determine and adjust the required settings
- Operates in extended temperature range of -40° to +85° C
- Automatically compensates for baseline wander by removing DC offset from the input signal
- Assembled with low EMI emissions IC and fully metallic housings
- Automatic dependent interface (DI) crossover, eliminating the need for crossover cables or cross-wire (MDIX) ports
- Bail latch provides ease of extraction
- Compact RJ45 connector assembly
- Data is scrambled to reduce radiated emission
- Power consumption is 610mW typical
- Fully RoHS compliant
- The BCM54616S physical layer IC (PHY) can be accessed via I²C interface:
PHY address = "ACh"
EEPROM address = "A0h"



Applications

- 1000 Mbps data rate in excess of 100 meters of Category 5/5e cable
- Industrial temperature environments -40° to +85° C
- Networking equipment
- Switch-to-switch interface
- Routers

Regulatory and Standards Compliance

- Compliant with IEEE 802.3:2000
- FCC Part 15, Class A
- EN55022 Class A
- CE
- E55024 Immunity standard and ESD



Bel Modules
28 Turkey Court, Turkey Mill, Ashford Road
Maidstone Bel ME 14 5PP UK

+44 1622 757 395
techhelp@belfuse.com
belfuse.com

SFP-1GBT-06

SFP Copper Transceiver 1000Base-T to GBIC

SFP-1GBT-06 Module Specifications

Parameter	Symbol	Min	Type	Max	Units	Notes
Supply Voltage	V _{DD3}	3.13	3.3	3.46	V	
Supply Current	I _S		185		mA	1000 Base-T

SFP Host Serial Interface (TX/RX)	Symbol	Min	Type	Max	Units	Notes
Line Frequency	F _{LINE}		125		MHz	
TX Output Impedance	Z _{TX_OUT}		100		Ω	Differential
RX Output Impedance	Z _{RX_IN}		100		Ω	Differential
Clock Frequency			25		MHz	
Rise/Fall Time	T _R /T _F		4		ns	20% - 80%
RMS Phase Jitter	F _J			1.5	ps-rms	F _J = 12 kHz to 20 MHz offset frequency

Environmental Specifications	Symbol	Min	Type	Max	Units	Notes
Operating Temp	T _{OP}	-40		+85	°C	Case temperature
Storage Temp	T _{STG}	-40		+85	°C	Ambient temperature

SFP Host Connector Electrical Interface Descriptions

Pin	Name	Descriptions
1	VeeT	Transmitter ground (common with receiver ground)
2	TX Fault	Transmitter fault is internally tied to transmit ground and is not supported
3	TX Disable	Disable PHY when logic '1'. Internal Pull Down
4	MOD-DEF2	Signal SDA (data) of the two-wire serial interface
5	MOD-DEF1	Signal SCL (clock) of the two-wire serial interface
6	MOD-DEF0	This pin is internally tied to transmit ground
7	Rate Select	Not implemented. This Pin is floating internally
8	LOS	Logic '1' when no signal or linked at 10Base-T
9	VeeR	Receiver ground (common with transmitter ground)
10	VeeR	Receiver ground (common with transmitter ground)
11	VeeR	Receiver ground (common with transmitter ground)
12	RD-	Differential Transmitter Output. User to terminate 100Ω differential at host. AC Coupled within SFP.
13	RD+	Differential Transmitter Output. User to terminate 100Ω differential at host. AC Coupled within SFP.
14	VeeR	Receiver ground (common with transmitter ground)
15	VccR	3.3V power
16	VccT	3.3V power
17	VeeT	Transmitter ground (common with receiver ground)
18	TD+	Differential Receiver Input. 100Ω differential termination & AC Coupling within SFP.
19	TD-	Differential Receiver Input. 100Ω differential termination & AC Coupling within SFP.
20	VeeT	Transmitter ground (common with receiver ground)

SFP-1GBT-06

SFP Copper Transceiver 1000Base-T to GBIC

GBIC Installation Guide

Part Number	Link Indicator on Rx_LOS Pin	Auto-Negotiation enabled by default	Interface	Duplex Mode
SFP-1GBT-06	Yes	Yes	GBIC 10/100/1000Base-T	Full

- Rx_LOS is always ENABLE.
High → Not linked or linked at 10Base-T.
Low → Linked to link-partner.
- Customer's MAC should be setup for **SGMII interface with Auto-Negotiation** and the preferred mode of operation. In most cases there is no need to access the PHY registers of the Broadcom PHY within the SFP-1GBT-06 Transceiver.
- The transceiver will automatically detect the advertised speed and mode of operation via the host of the link-partner.

GBIC to SGMII-Copper:

- If the SGMII Interface is required, Bel would recommend the SFP-1GBT-05 Transceiver for installation.
- However, SFP-1GBT-06 Transceiver can also be configured to operate in SGMII (10/100/1000Base-T) interface by accessing the Broadcom PHY registers via "0xAC":
 1. Write register 18h, shadow 07h bit [7] = 0 (Disable RGMII Mode)
 2. Write register 1Ch, shadow 1Fh bit [0] = 1 (Enable Fiber register bank)
 3. Write register 00h, bit [11] = 1 (Power-down SerDes interface)
 4. Write register 1Ch, shadow 1Fh bit [2:1] = 10 (Configure the BCM54616S in SGMII to Copper mode)
 5. Write register 00h, bit [11] = 0 (Power-up SerDes interface)
 6. Write register 1Ch, shadow 1Fh bit [0] = 0 (Enable Copper register bank)
 7. Write register 00h, bit [11] = 0 (Power-up Copper interface)

MAC Auto-Negotiation vs. MAC without Auto-Negotiation:

In case MAC does not have Auto-Negotiation capability, the Auto-Negotiation of the SFP-1GBT-06 can also be disabled by clearing the Broadcom PHY register 00h, bit12 to "0", before connecting the Bel transceiver to the link partner.

Mechanical

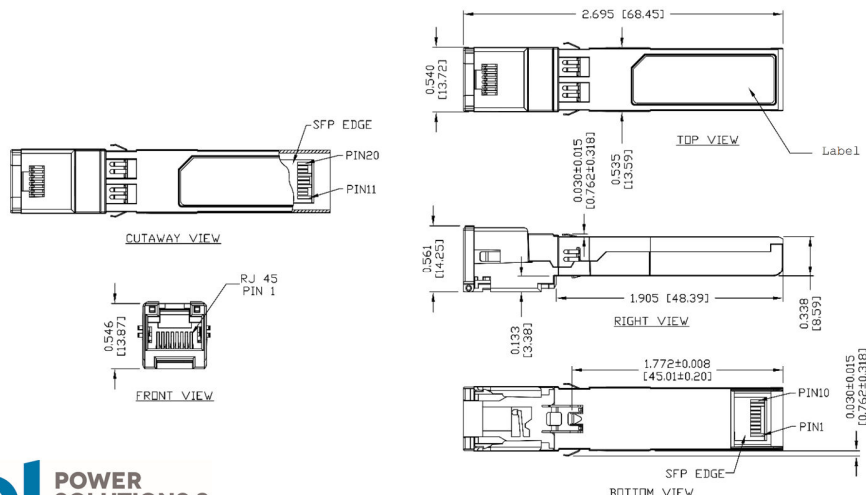

X-ON Electronics

Largest Supplier of Electrical and Electronic Components

Click to view similar products for [Fibre Optic Transmitters, Receivers, Transceivers](#) category:

Click to view products by [Bel Fuse](#) manufacturer:

Other Similar products are found below :

[STV.2413-574-00262](#) [TRPRG1VA1C000E2G](#) [TOTX1350\(V,F\)](#) [FTLX3813M349](#) [SCN-1428SC](#) [LTK-ST11MB](#) [HFD8003-002/XBA](#)
[HFD3020-500-ABA](#) [FTLF1429P3BCVA](#) [S6846](#) [SCN-2638SC](#) [FTL410QE4N](#) [FTLC9555FEPM](#) [TQS-QG4H9-J83](#) [SCN-1570SC](#) [SCN-](#)
[1601SC](#) [SCN-1338SC](#) [SFPPT-SR3-01](#) [HFD8003-500-XBA](#) [SCN-1383SC](#) [2333569-1](#) [LNK-ST11HB-R6](#) [FTL4C1QL3L](#) [FTL4C1QE3L](#)
[FTL4C1QL3C](#) [SPTSHP3PMCDF](#) [SPTSBP4LLCDF](#) [SPTMBP1PMCDF](#) [SPTSHP2PMCDF](#) [SF-NLNAMB0001](#) [SPTSHP2SLCDF](#)
[SPTSQP4LLCDF](#) [1019682](#) [1019683](#) [1019705](#) [HFBR-1415Z](#) [AFBR-5803ATQZ](#) [AFBR-5803ATZ](#) [PLR135/T9](#) [TGW-Q14BB-FCQ](#) [AFBR-](#)
[5803AZ](#) [TQS-Q1LH8-XCA03](#) [TQS-Q1LH8-XCA05](#) [TQS-Q1LH8-XCA10](#) [TQS-Q1LH9-2CA](#) [HFBR-1414Z](#) [HFBR-1527Z](#) [HFBR-1528Z](#)
[HFBR-2406Z](#) [HFBR-2505AZ](#)