

THE INFORMATION CONTAINED HEREIN IS CONSIDERED 'PROPRIETARY' TO BEL FUSE INC. AND SHALL NOT BE COPIED, REPRODUCED OR DISCLOSED WITHOUT THE WRITTEN APPROVAL OF BEL FUSE INC.

RoHS



ELECTRICAL CHARACTERISTICS @ 25°C

CURRENT CAPABILITY FOR POWER LINES:	400 mA MAX
1.0 INDUCTANCE:	
(P4-P6)	350uH MIN. @ 0.1V, 100KHz, 8mA DC BIAS
(P1-P3)	350uH MIN. @ 0.1V, 100KHz, 8mA DC BIAS
2.0 TURNS RATIO:	
(P4-P5-P6):(J3-J6)	1CT : 1CT ± 3%
(P1-P2-P3):(J1-J2)	1CT : 1CT ± 3%
3.0 LEAKAGE INDUCTANCE:	
P4-P6 (WITH J3 AND J6 SHORT)	0.3 uH MAX. @ 1MHz
P1-P3 (WITH J1 AND J2 SHORT)	0.3 uH MAX. @ 1MHz
4.0 INTERWINDING CAPACITANCE:	
(P4,P5,P6) TO (J3,J6)	30pF MAX. @ 1 MHz
(P1,P2,P3) TO (J1,J2)	30pF MAX. @ 1 MHz
5.0 DC RESISTANCE:	
(J3-J6)=(J1-J2)	1.2 OHMS MAX.
6.0 RETURN LOSS: (P4-P6)=100 OHMS AND (P1-P3)=100 OHM REF.	
1MHz TO 30MHz	-18dB MIN.
60MHz TO 80MHz	-12dB MIN.
NOTE: 100 OHMS CONNECTED TO (J1-J2) OR (J3-J6).	
7.0 DIELECTRIC WITHSTAND:	
(J1, J2) TO (P1, P3)	1500 VAC
(J3, J6) TO (P4,P6)	1500 VAC
8.0 INSERTION LOSS:RS=RL=100 ohms	
100KHz TO 100MHz	-1.1 dB
9.0 RISE TIME: RS=100 OHMS AND RL = 100 OHMS	
OUTPUT VOLTAGE = 1 V peak	3.0 nS MAX
PULSE WIDTH= 112nS	3.0 nS MAX
10.0 CROSS TALK:	
1MHz TO 100MHz	-40 dB TYP
11.0 COMMON TO COMMON MODE ATTENUATION:	
30MHz TO 100MHz	-35dB TYP
12.0 OPERATING TEMPERATURE RANGE:	0°C TO +70°C

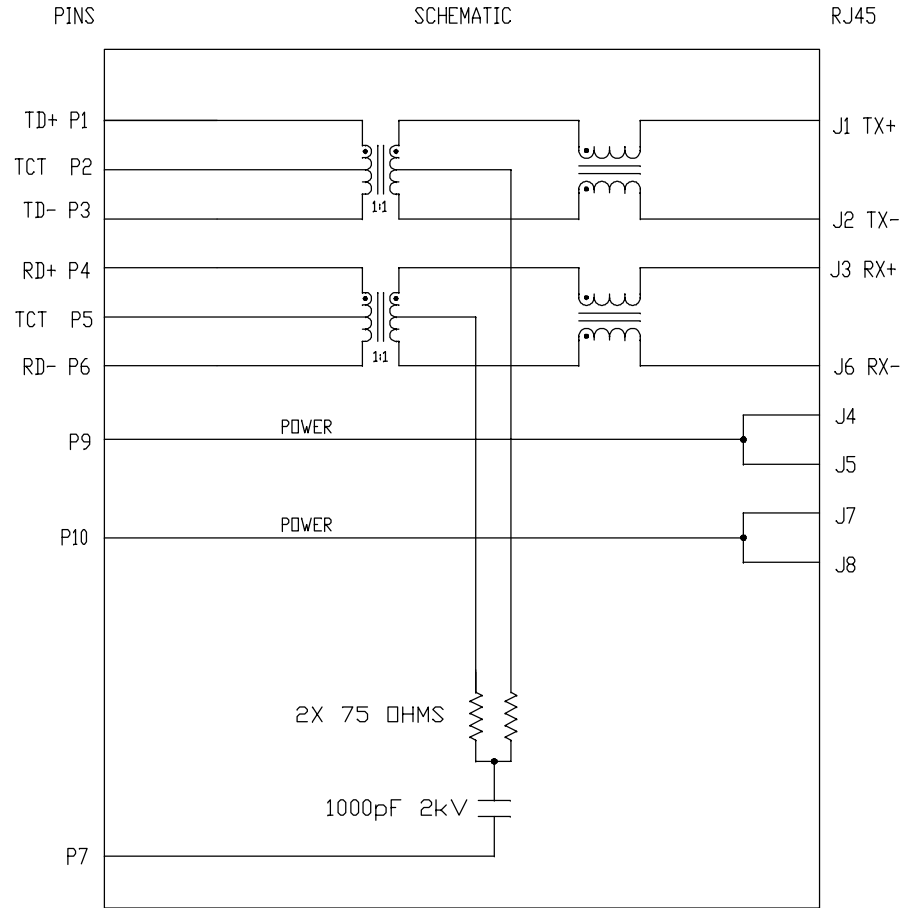

NOTES
1.0 PINS WITHOUT ELECTRICAL CONNECTION ARE OMITTED

REV. : C PAGE : 2

ORIGINATED BY
CHOW WANCHUNG
DATE 2021-01-06
DRAWN BY
TANG YUAN
DATE 2021-01-06

TITLE
MagJack®
10/100BT
VERTICAL, SHIELDED

PART NO. / DRAWING NO.
SI-46020-F
FILE NAME
SI-46020-F_C.DWG

STANDARD DIM. TOL. IN INCH	[] METRIC DIM. AS REF.
.X	UNIT : INCH [mm]
.XX	SCALE : N/A
.XXX	SIZE : A4



THE INFORMATION CONTAINED HEREIN IS CONSIDERED 'PROPRIETARY' TO BEL FUSE INC. AND SHALL NOT BE COPIED, REPRODUCED OR DISCLOSED WITHOUT THE WRITTEN APPROVAL OF BEL FUSE INC.

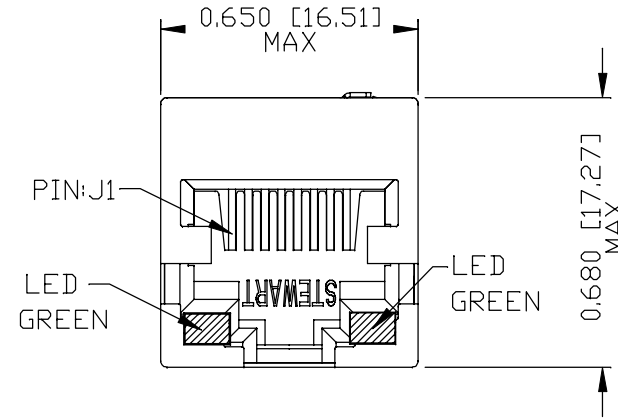
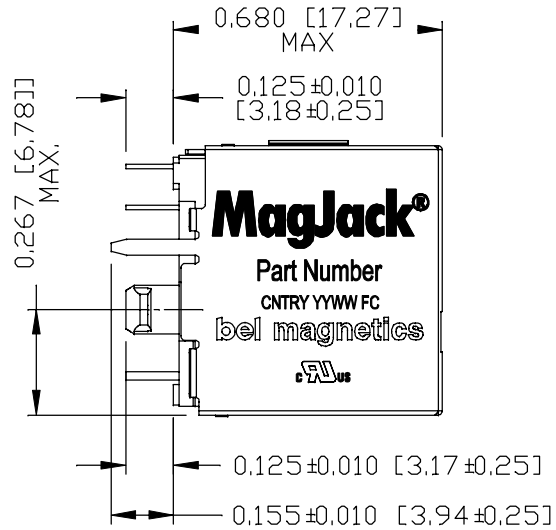

NOTES:

1. CONNECTOR MATERIALS:

- HOUSING: THERMOPLASTIC UL94 V-0
- CONTACT/SHIELD: COPPER ALLOY
- SHIELD PLATING: NICKEL OR TIN
- CONTACT PLATING: 50 MICRO-INCH SELECTIVE HARD GOLD PLATING OR EQUIVALENT IN CONTACT AREA

2. PIN NOT ELECTRICALLY CONNECTED MAYBE OMITTED. SEE ELECTRICAL DRAWING FOR OMITTED PINS.

3. TOLERANCES COMPLY WITH F.C.C. DIMENSION REQUIREMENTS.

4. THE PRODUCT IS ROHS COMPLIANT.

 UL RECOGNIZED - FILE #E474585.

5. THE PART IS RECOMMENDED FOR WAVE SOLDERING. THE SUGGESTED PEAK WAVE SOLDERING CONDITION IS 260°C MAX AND 10 SECONDS MAX.

ORIGINATED BY
SANDY LIN
DATE 2021-01-06
DRAWN BY
RUAN WENJUN
DATE 2021-01-06

TITLE
MagJack®
10/100BT
VERTICAL, SHIELDED

PART NO. / DRAWING NO.
SI-46020-F
FILE NAME
SI-46020-F_C.DWG

STANDARD DIM. TOL. IN INCH		[] METRIC DIM. AS REF.	
.X		UNIT : INCH [mm]	
.XX		SCALE : N/A	
.XXX	±0.005		SIZE : A4

REV. : C PAGE : 3



THE INFORMATION CONTAINED HEREIN IS CONSIDERED 'PROPRIETARY' TO BEL FUSE INC. AND SHALL NOT BE COPIED, REPRODUCED OR DISCLOSED WITHOUT THE WRITTEN APPROVAL OF BEL FUSE INC.

RoHS



LED SPECIFICATION			
STANDARD LED	WAVELENGTH	FORWARD V (MAX)	*(TYP)
GREEN	570 nm	2.5 V	2.2 V

*WITH A FORWARD CURRENT OF 20 mA (TYP)

LED POLARITY
(ENLARGED VIEW)

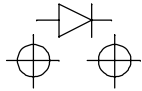

SINGLE COLOR LED

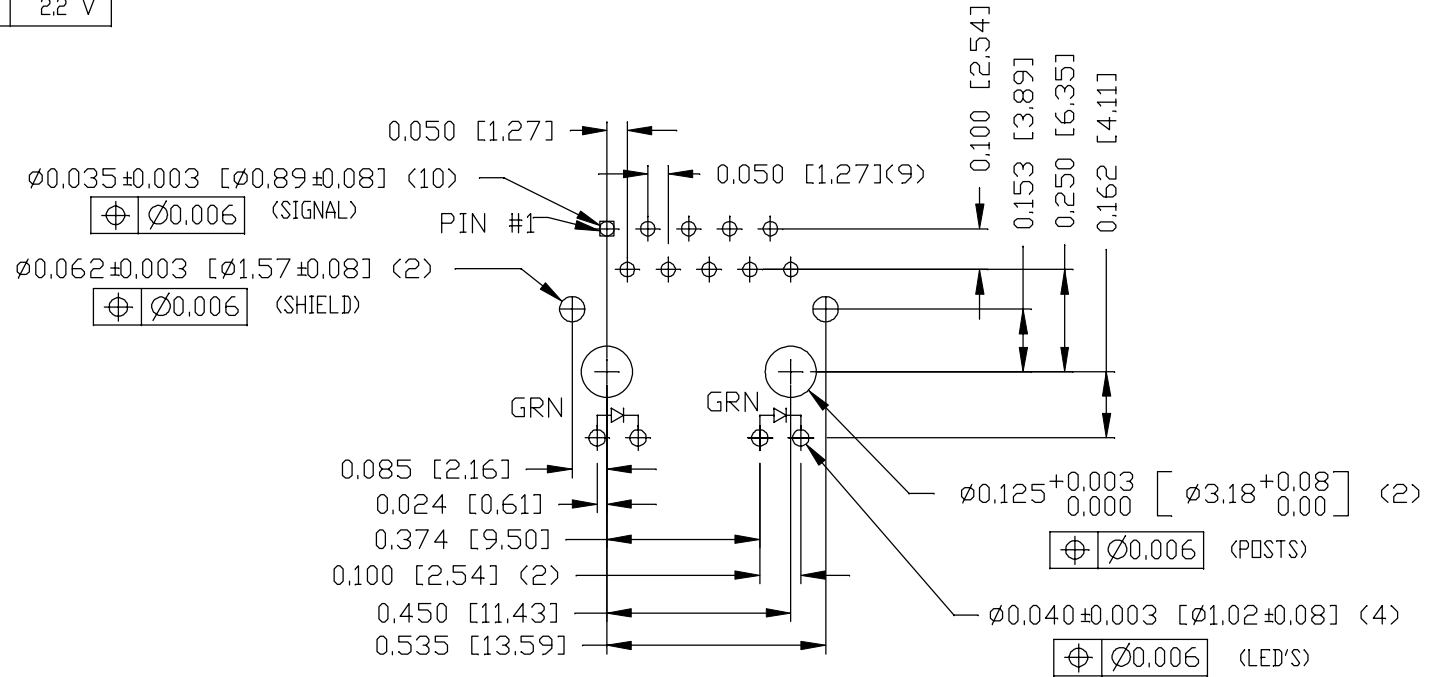

P.C.B. RECOMMENDED HOLE LAYOUT
SEEN FROM COMPONENT SIDE

ALL CENTERLINE DIMENSIONS ARE BASIC.

ORIGINATED BY
SANDY LIN
DATE 2021-01-06

TITLE
MagJack®
10/100BT
VERTICAL, SHIELDED

DRAWN BY
RUAN WENJUN
DATE 2021-01-06

PART NO. / DRAWING NO.
SI-46020-F

FILE NAME
SI-46020-F_C.DWG

STANDARD DIM.
TOL. IN INCH [] METRIC DIM.
AS REF.

.X		UNIT : INCH [mm]
.XX		SCALE : N/A
.XXX	±0.005	SIZE : A4

REV. : C PAGE : 4



a bel group

X-ON Electronics

Largest Supplier of Electrical and Electronic Components

Click to view similar products for [Modular Connectors / Ethernet Connectors](#) category:

Click to view products by [Bel Fuse](#) manufacturer:

Other Similar products are found below :

[8949-H88/06BLKA/SN](#) [74441-0010/BKN](#) [MP1010RX-1000](#) [MP44RX-1000](#) [PHJ-4P4C-1-V-4](#) [PHP-6P6C-5](#) [GAX-3-66](#) [GAX-8-62](#) [GDCX-PA-66-50](#) [GDCX-PN-64](#) [GDCX-PN-66](#) [GDCX-PN-66-50](#) [GDLX-A-66](#) [GDLX-N-66](#) [GDLX-S-66](#) [GDLX-S-88K](#) [GDLX-SMT-S-88](#) [GDTX-S-88-50](#) [GDX-PA-1010](#) [GLX-N-1010M-BLK](#) [GLX-S-88M-BLK](#) [GMX-N-1010](#) [GMX-S-1010](#) [GMX-S-66](#) [GMX-SMT4-N-88](#) [GPX-2-64](#) [GSGX-N-2-88](#) [GSGX-N-4-88](#) [GSX-NS2-88-3.05](#) [GSX-NS2-88-3.05-50](#) [GSX-NS-88-3.05-50](#) [PT-108A-8C-UL](#) [PT-J951-8C](#) [PTS-J531-8CS-50UL](#) [1-1775629-2](#) [A-2014-0-4](#) [GWLX-S-88-GR](#) [GWLX-S9-88-YG](#) [DC-1021-8-WH-6](#) [1300530003](#) [1324640-4](#) [RJ11FTVC2G](#) [RJ11FTVC2N](#) [RJFTVX2SA1G](#) [132764-001](#) [1413235](#) [MP88X-1000](#) [MPS88RX-5000](#) [E5288-S000K3-L](#) [E5908-15A242-L](#)