

Outline:

BL1084 is a series of low dropout three terminal regulators with a dropout of 1.4V at 5A load current.

Other than a fixed version (Vout = 1.8V, 2.5V, 3.3V, 5.0V), BL1084 has an adjustable version. The adjustable version can set the output voltage with two external resistors.

BL1084 offers thermal shut down and current limit functions, to assure the stability of chip and power system.

The BL1084 series is available in standard packages of TO-263-2L, TO-263-3L, TO-220 and TO-252.

Features:

- Other than a fixed version and an adjustable version, output value can be customized on command.
- Maximum output current is 5A
- Range of operation input voltage: Max 18V
- Line regulation: 0.2% (Typical)
- Load regulation: 0.2% (Typical)
- Environment Temperature: 0°C~80°C

Applications:

- Power Management for Computer Mother Board, Graphic Card
- Battery Charger
- Post Regulators for Switching Supplies
- Microprocessor Supply

Pin Configuration:

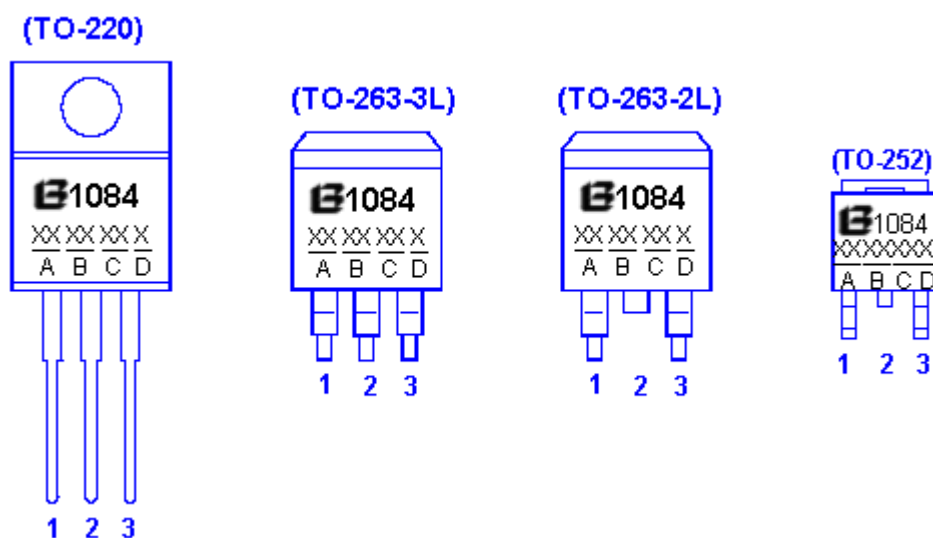

Marking information:

- A:
Means Manufacture weeks
- B:
Means Manufacture LOT No.
- C:
Means Output Voltage Value
- D:
Means Temp. Range&Rohs Std

Pin Description:

Fixed Version

Pin No.	Symbol	Definition
1	GND	Ground
2	Vout	Output
3	Vin	Input

Adjustable Version

Pin No.	Symbol	Definition
1	Adj.	Adjustable
2	Vout	Output
3	Vin	Input

Ordering Information:

BL1084-XX X X

Package Type:

S: TO-263-2L
 S1: TO-263-3L
 Y: TO-252
 Z: TO-220

Temp. Range & Rohs Std.:

C: 80°C & Pb-free Rhos Std
 Z: 80°C & Pb/Sn Plating

Output Voltage:

18.....1.8V
 25.....2.5V
 33.....3.3V
 50.....5.0V
 Default: Adjustable Version

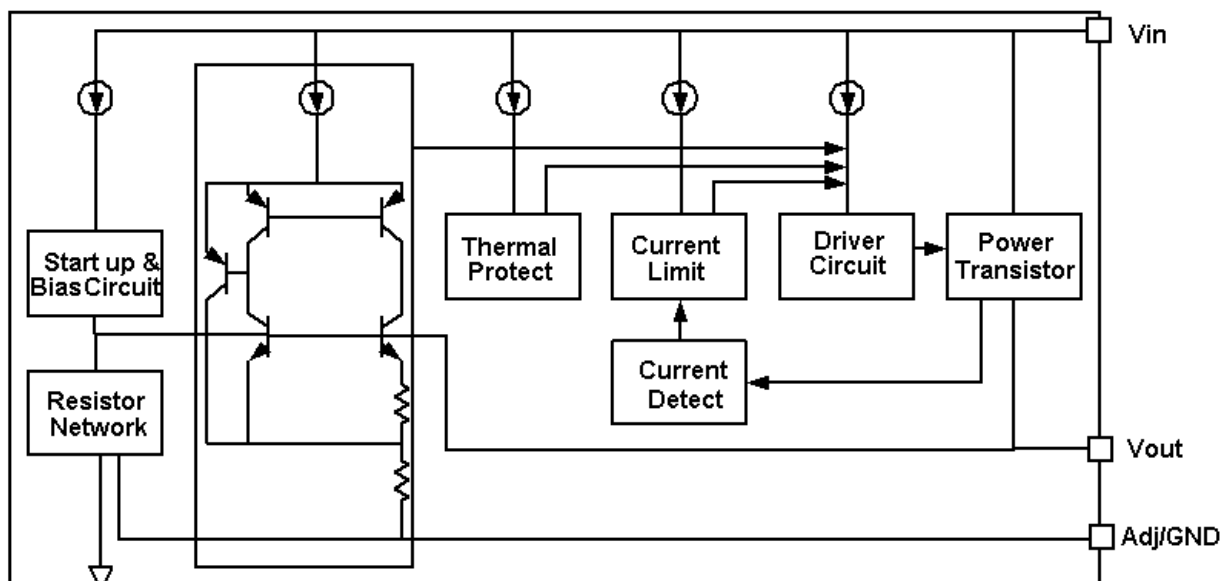
Block Diagrams:

Absolute Maximum Ratings:

Maximum Input Voltage-----	18V
Junction Temperature (T _J)-----	150°C
Environment Temperature (T _A) -----	80°C
Storage Temperature (T _S)-----	-65~150°C
Lead Temperature and Time -----	260°C,10S

Recommended Work Conditions:

Item	Min	Recommended	Max	Unit
Input Voltage Range			15	V
Environment Temperature	0		80	°C

Electrical Characteristics (Table 1):

Symbol	Parameter	Conditions	Min	Typ	Max	Unit
V _{ref}	Reference Voltage	I _{out} =10mA, V _{in} -V _{out} =3V 10mA ≤ I _{out} ≤ 5A, 1.5V ≤ V _{in} -V _{out} ≤ 5V	1.238 1.225	1.25 1.25	1.262 1.275	V
V _{out}	Output Voltage	BL1084-1.80V I _{out} =0mA, V _{in} =4.8V, T _j =25°C 10mA ≤ I _{out} ≤ 5A, 3.4V ≤ V _{in} ≤ 7V	1.782 1.764	1.80 1.80	1.818 1.836	V
		BL1084-2.50V I _{out} =0mA, V _{in} =5.5V, T _j =25°C 10mA ≤ I _{out} ≤ 5A, 4.1V ≤ V _{in} ≤ 7V	2.475 2.45	2.50 2.50	2.525 2.55	V

		BL1084-3.3V I _{out} =0mA, V _{in} =6.3V, T _j =25°C 10mA ≤ I _{out} ≤ 5A, 4.9V ≤ V _{in} ≤ 8V	3.267 3.234	3.3 3.3	3.333 3.366	V
		BL1084-5.0V I _{out} =0mA, V _{in} =8.0V, T _j =25°C 10mA ≤ I _{out} ≤ 5A, 6.6V ≤ V _{in} ≤ 10V	4.95 4.90	5.0 5.0	5.05 5.10	V
ΔV _{out}	Line Regulation (note 1)	BL1084-ADJ I _{out} =10mA 2.85V ≤ V _{in} ≤ 12V		0.035	0.2	%
		BL1084-1.8V I _{out} =10mA 3.4V ≤ V _{in} ≤ 12V		7	15	mV
		BL1084-2.5V I _{out} =10mA 4.1V ≤ V _{in} ≤ 12V		7	15	mV
		BL1084-3.3V I _{out} =10mA 4.9V ≤ V _{in} ≤ 12V		7	15	mV
		BL1084-5.0V I _{out} =10mA 6.6V ≤ V _{in} ≤ 12V		7	15	mV
ΔV _{out}	Load Regulation (note 1,2)	BL1084-ADJ V _{in} -V _{out} =3V, 10mA ≤ I _{out} ≤ 5A		0.2	0.4	%
		BL1084-1.8V V _{in} -V _{out} =3V, 0 ≤ I _{out} ≤ 5A		16	30	mV
		BL1084-2.5V V _{in} -V _{out} =3V, 0 ≤ I _{out} ≤ 5A		16	30	mV
		BL1084-3.3V V _{in} -V _{out} =3V, 0 ≤ I _{out} ≤ 5A		16	30	mV
		BL1084-5.0V V _{in} -V _{out} =3V, 0 ≤ I _{out} ≤ 5A		16	30	mV
V _{in} -V _{out}	Dropout Voltage (note 3)	ΔV _{out} , ΔV _{ref} = 1%, I _{out} = 5A		1.4		V
I _{limit}	Current Limit	V _{in} -V _{out} =3V, T _j =25°C		7		A
	Minimum Load Current (note 4)	BL1084-ADJ		3	10	mA

I_q	Quiescent Current	$V_{in}=10V$		5	10	mA
I_{Adj}	Adjust Pin Current (Adjustable Version)	$V_{in}=4.25V$, $I_{out}=10mA$		45	110	μA
Ripple Rejection		$F=120Hz$, $C_{out}=25\mu F$ (tan), $I_{out}=5A$, $V_{in}-V_{out}=3V$	60			dB
I_{change}	Adjust Pin Current Change	$10mA \leq I_{out} \leq 5A$ $1.5V \leq V_{in}-V_{out} \leq 6V$		0.2	5	μA
	Temperature Stability	$I_{out}=10mA$, $V_{in}-V_{out}=1.5V$			0.5	%
θ_{JC}	Thermal Resistance junction to case	TO-252 TO-263 TO-220		12.5 3 3		$^{\circ}C / W$

Note:

- Note1: The Parameters of Line Regulation and Load Regulation in Table1 are tested under constant junction temperature.
- Note2: When I_{out} varies between 0~5A, $V_{in}-V_{out}$ varies between 1.5V~6V under constant junction temperature, the parameter is satisfied the criterion in table. If temperature varies between $0^{\circ}C \leq T_A \leq 80^{\circ}C$, it needs output current to be larger than 10mA to satisfy the criterion.
- Note3: Dropout Voltage is tested under $I_{out}=5A$ and the following testing conditions: First step is to find out the V_{out} value (V_{out1}) when $V_{in1}=V_{out1}+1.5V$, second step is to decrease V_{in} (V_{in2}) until V_{out} value is equal to $99\% * V_{out1}$ (V_{out2}). $V_{dropout}=V_{in2}-V_{out2}$.
- Note4: Minimum Load Current is defined as the minimum output current required to maintain regulation. When $1.5V \leq V_{in}-V_{out} \leq 6V$, the device is guaranteed to regulate if the output current is greater than 10mA.

Detailed Description:

BL1084 is a series of low dropout voltage, three terminal regulators. Its application circuit is very simple: the fixed version only needs two capacitors and the adjustable version only needs two resistors and two capacitors to work. It is composed of some modules including start-up circuit, bias circuit, bandgap, thermal shutdown, current limit, power transistors and its driver circuit and so on.

The thermal shut down and current limit modules can assure chip and its application system working safety when the environment temperature is larger than $80^{\circ}C$ or output current is larger than 5.2A.

The bandgap module provides stable reference voltage, whose temperature coefficient is compensated by careful design considerations. The temperature coefficient is under $100ppm/^{\circ}C$. And the accuracy of output voltage is guaranteed by trimming technique.

Typical Application :

BL1084 has an adjustable version and fixed versions, Chart1 is its typical application:

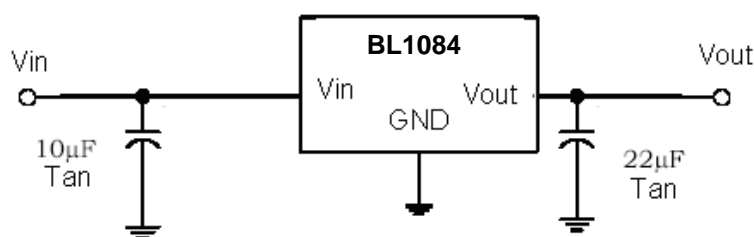
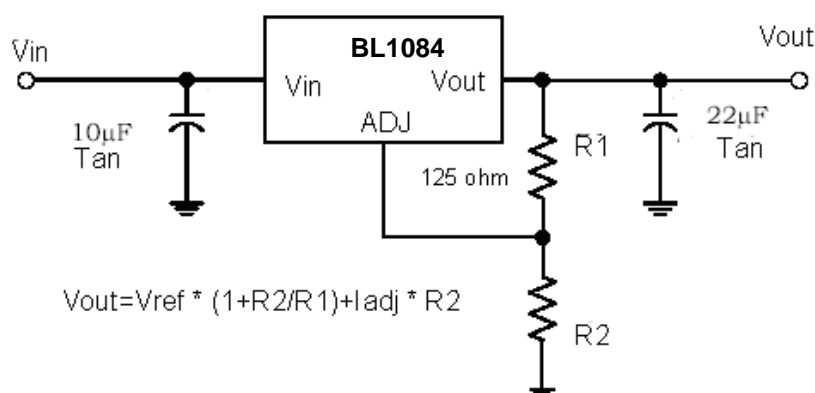

Typical Application of BL1084

Application Hints:

1. Recommend using 10uF tan capacitor as bypass capacitor for all application circuit.
2. Recommend using 22uF tan capacitor to assure circuit stability.
3. Using a bypass capacitor(C_{Adj}) between the adjust terminal and ground can improve ripple rejection, This bypass capacitor prevents ripple from being amplified as the output voltage is increased. The impedance of C_{Adj} should be less than the resistor's($R1$) which is between output and adjust pins to prevent ripple from being amplified at any ripple frequency. As $R1$ is normally in the range of $120\ \Omega \sim 200\ \Omega$, the value of C_{Adj} should satisfy this equation: $1/(2\pi * F_{ripple} * C_{adj}) < R1$. Recommend using 10uF tan capacitor.

Output Voltage of Adjustable Version:

The BL1084 adjustable version provide 1.25V Reference Voltage. Any output voltage between 1.25V~10V can be available by choosing two external resistors (connection method is shown in chart 1). In chart 1, $R1, R2$ is the two external resistors.

Explanation :

The output voltage of adjustable version satisfies this followed equation:
 $V_{Out} = V_{Ref} * (1 + R2/R1) + I_{Adj} * R2$. We can ignore I_{Adj} because I_{Adj} (about 50uA) is much less than the current of $R1$ (about 4mA).

How to choose $R1$: The value of $R1$ should be in the range of $120\ \Omega \sim 200\ \Omega$ to assure chip working normally without any load. To assure the electrical performance showed in table 1, the output current should be larger than 5mA. If $R1$ is too large, the minimum output current should be larger than 4mA , The best working condition is to assure that the output current exceeds 10mA.

Typical Performance Characteristics:

Dropout Voltage VS. Output Current

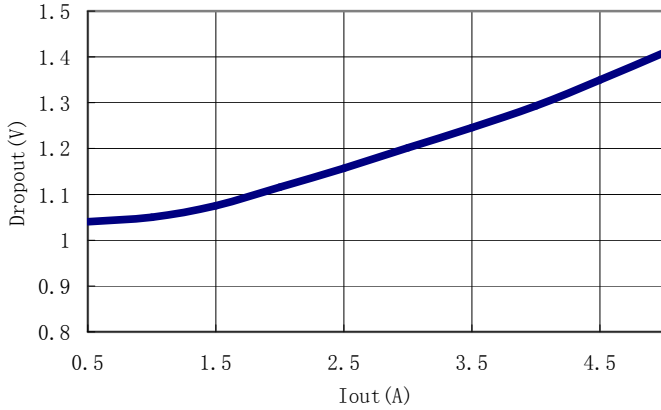

Output Voltage VS. Temperature

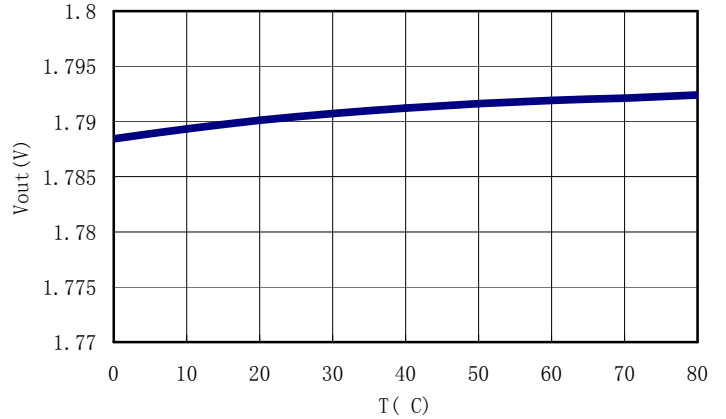

Output Voltage VS. Output Current

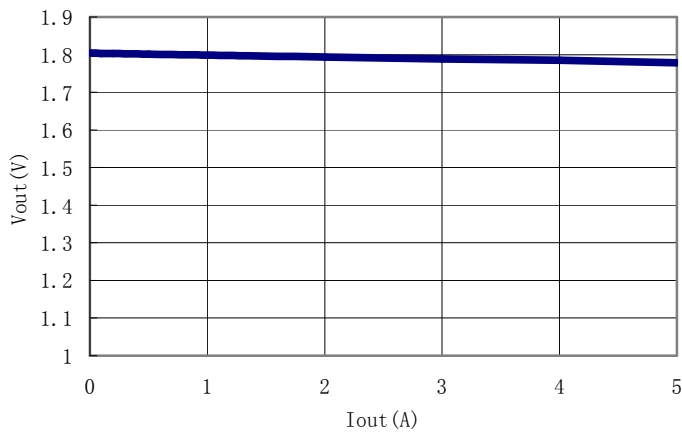

Load Transient Response

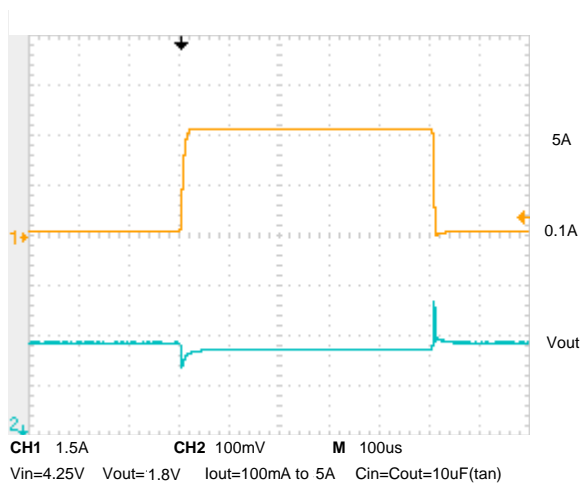

Line Transient Response

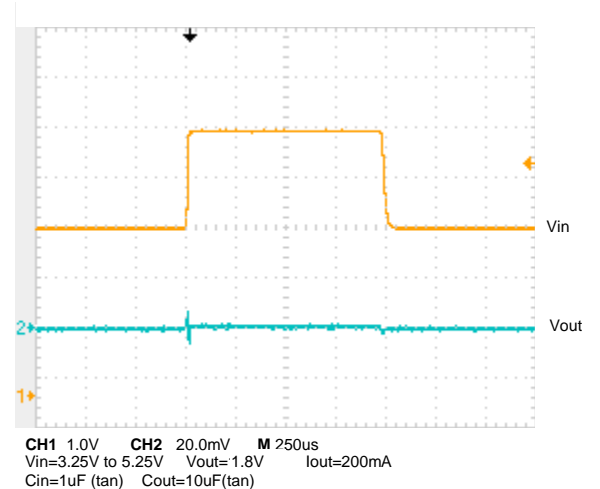

Package outline:
1.TO-252

Package	TO-252	Devices per reel	2500	Unit	mm
---------	--------	------------------	------	------	----

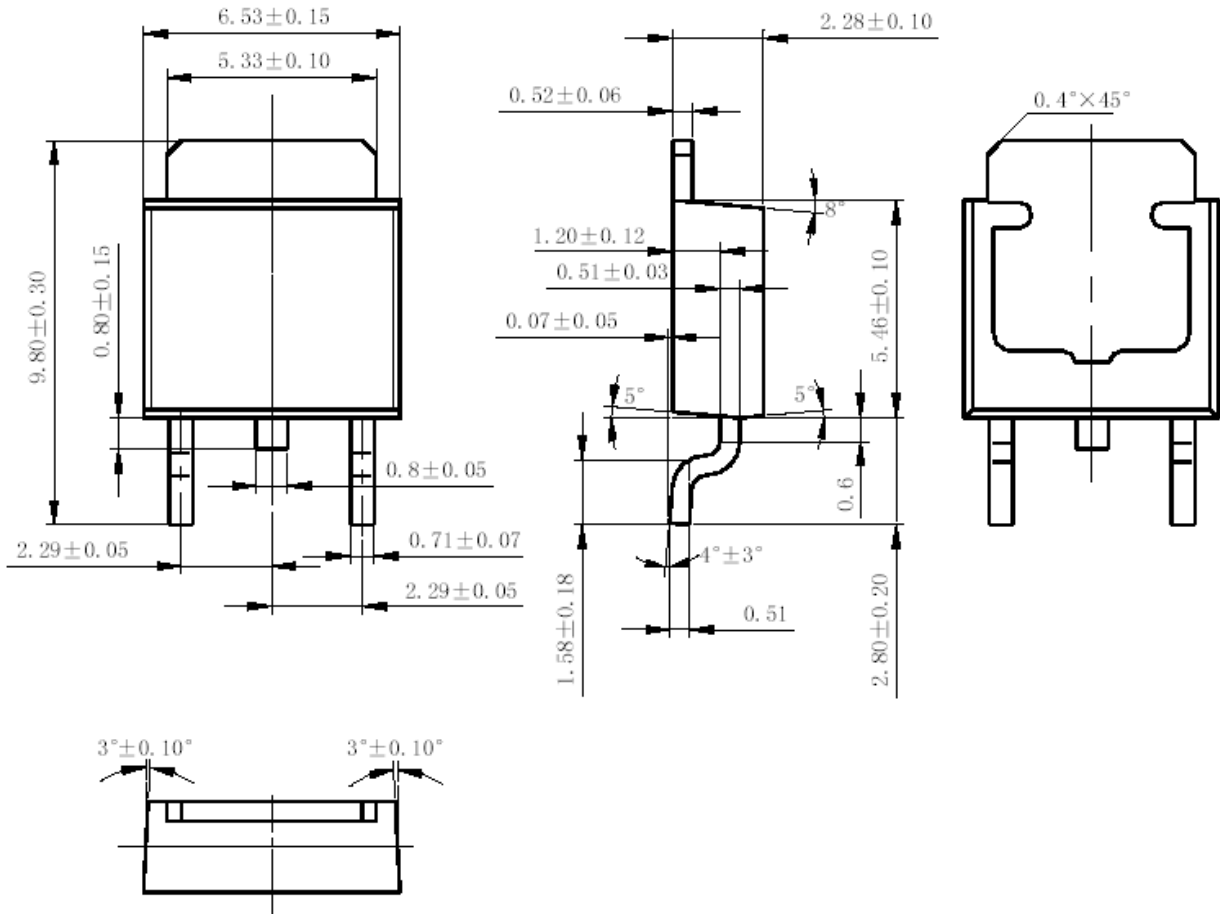
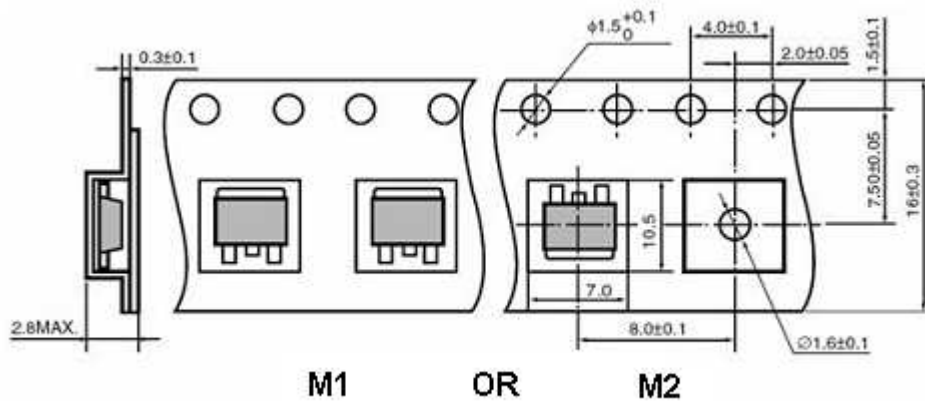
Package specification:

Taping dimension: (M1: Standard Type , M2: Customized)

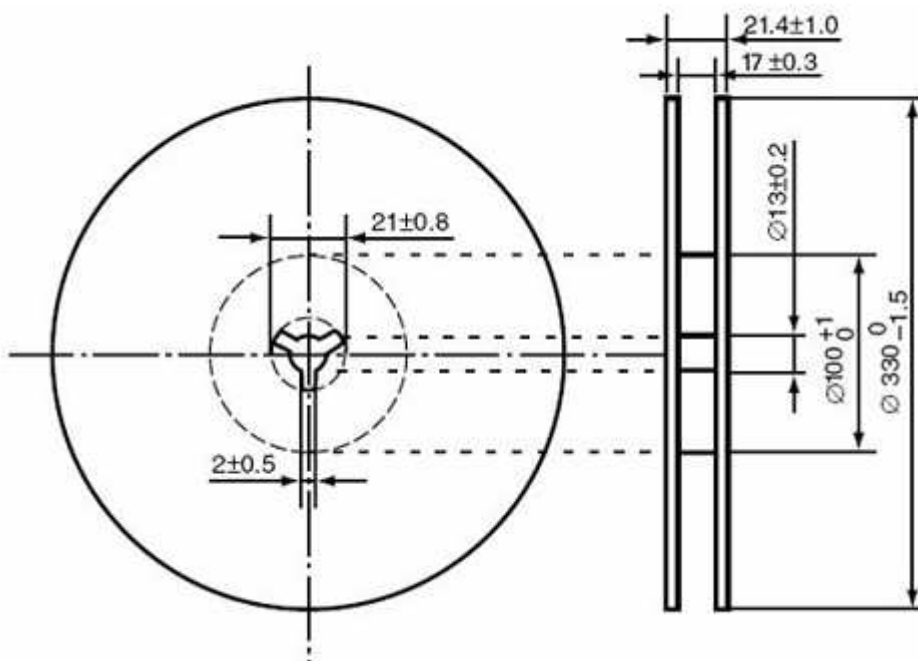
Taping reel dimension:



2.TO-220

Package	TO-220	Devices per tube	50	Unit	mm
---------	--------	------------------	----	------	----

Package specification:

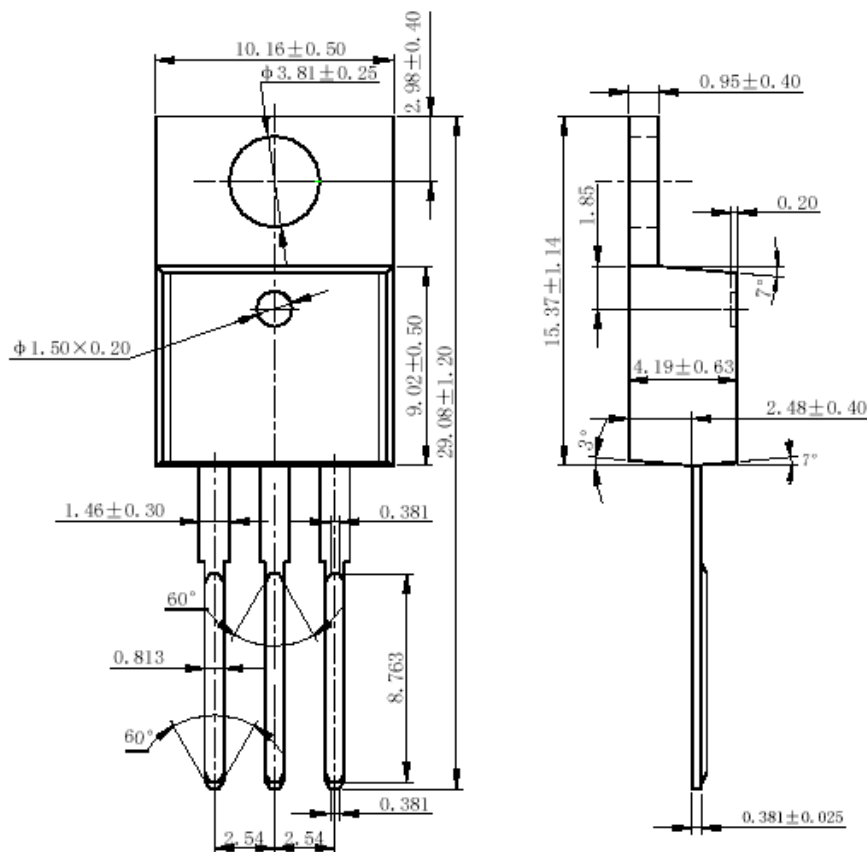

3.TO-263-2L

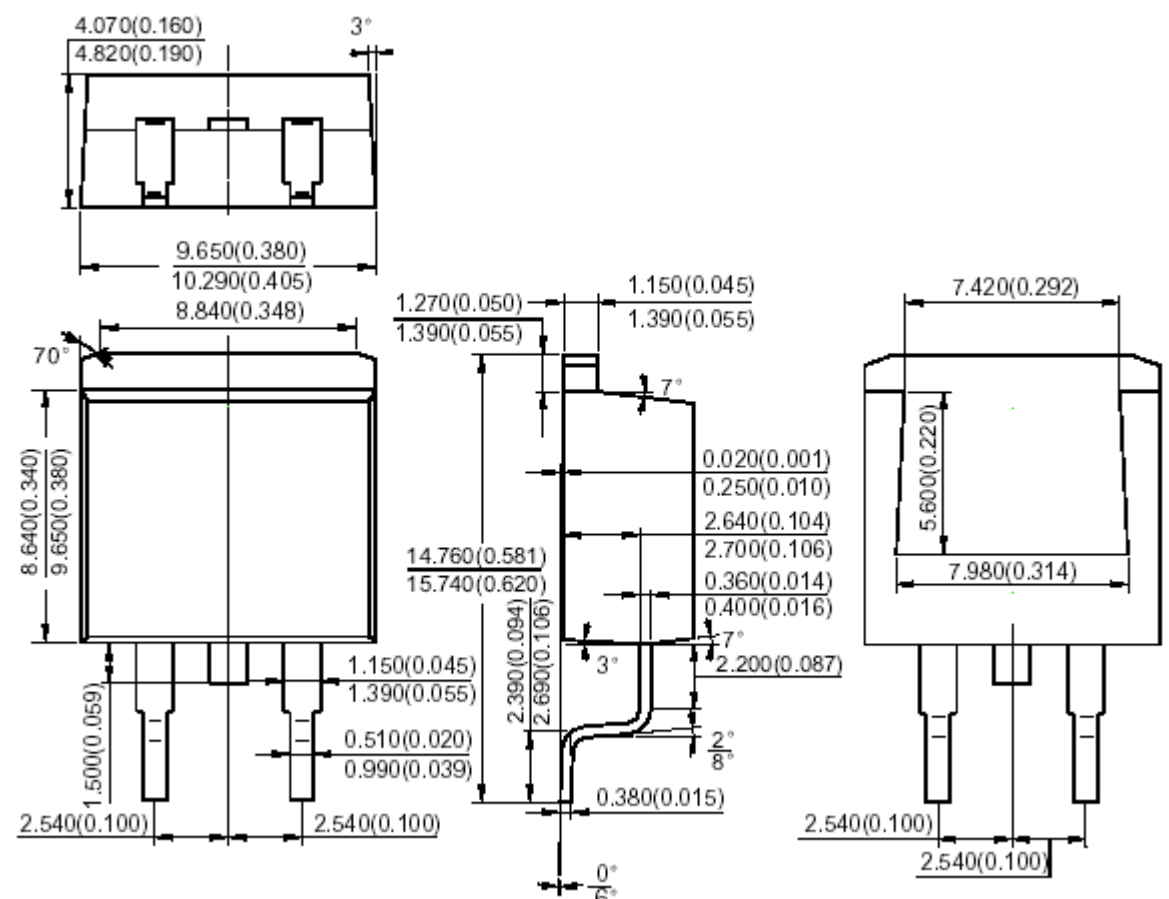
Package	TO-263	Devices per reel	800	Unit	mm
Package specification: 					

Taping dimension:

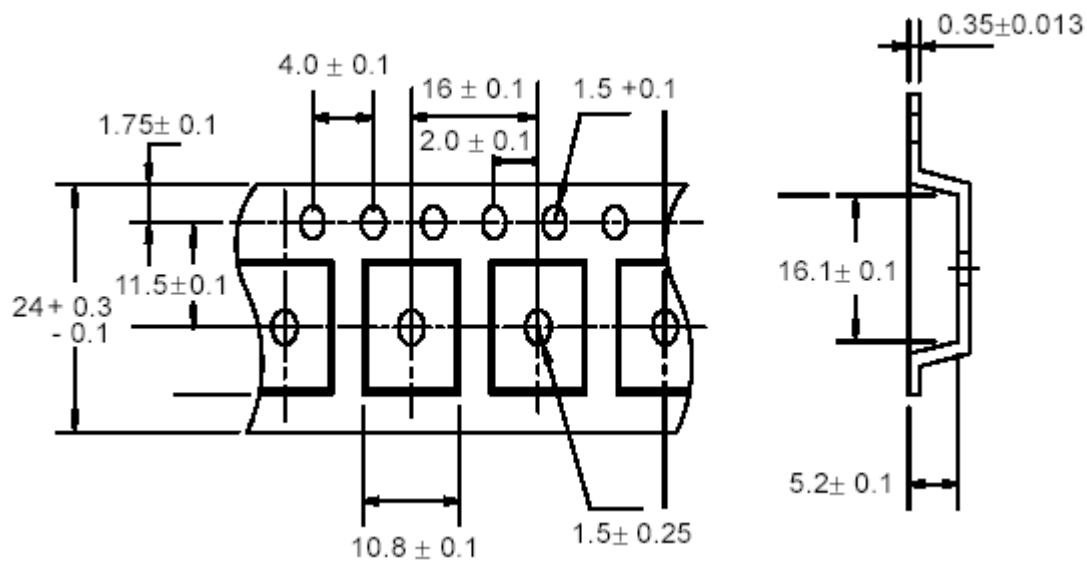

Taping reel dimension:

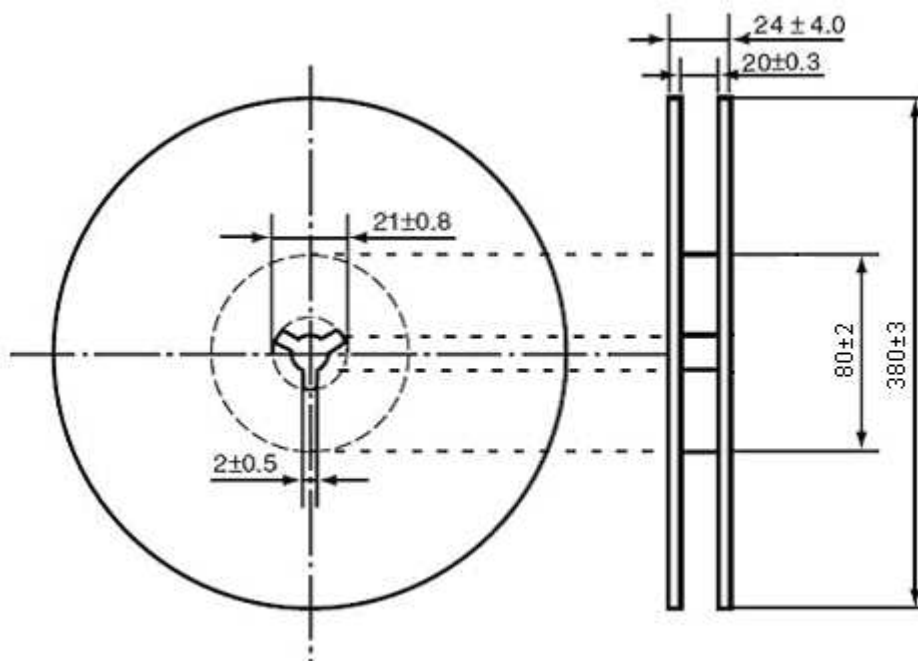

4.TO-263-3L

Package	TO-263	Devices per reel	800	Unit	mm
---------	--------	------------------	-----	------	----

Package specification:

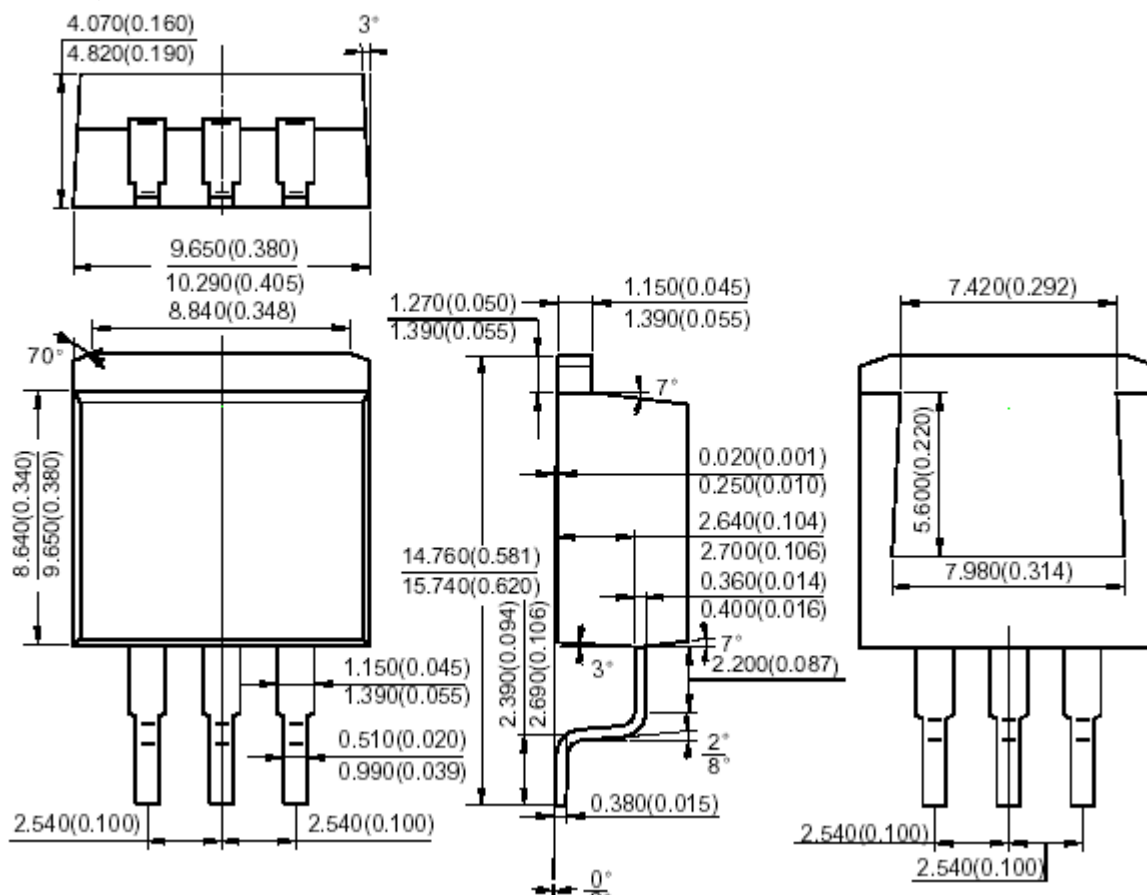

Taping dimension:

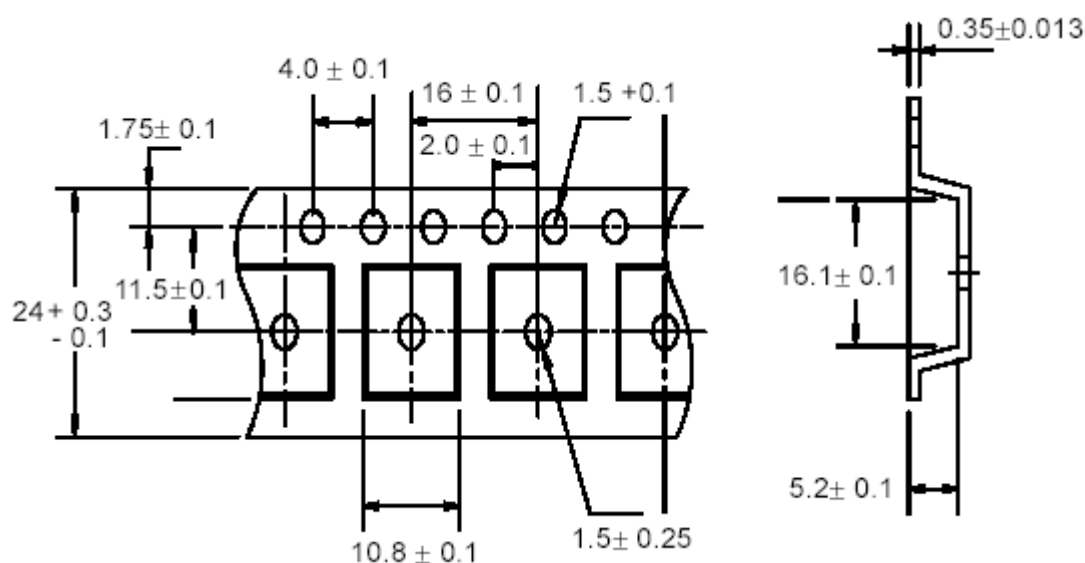

Taping reel dimension:

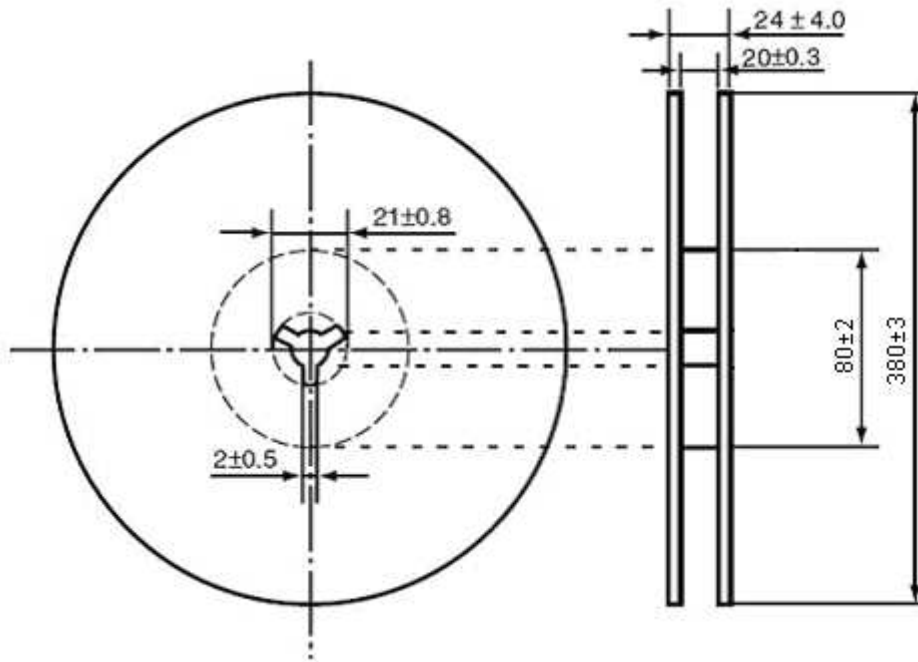

X-ON Electronics

Largest Supplier of Electrical and Electronic Components

Click to view similar products for [LDO Voltage Regulators](#) category:

Click to view products by [Belling](#) manufacturer:

Other Similar products are found below :

[AP7363-SP-13](#) [L79M05TL-E](#) [AP7362-HA-7](#) [PT7M8202B12TA5EX](#) [TCR3DF185,LM\(CT](#) [TCR3DF45,LM\(CT](#) [TLE4473G V52](#) [059985X](#)
[NCP4687DH15T1G](#) [701326R](#) [NCV8170AXV250T2G](#) [AP7315-25W5-7](#) [AP2111H-1.2TRG1](#) [ZLDO1117QK50TC](#) [AZ1117ID-ADJTRG1](#)
[TCR3DG12,LF](#) [MIC5514-3.3YMT-T5](#) [SCD7912BTG](#) [NCP154MX180270TAG](#) [SCD33269T-5.0G](#) [NCV8170BXV330T2G](#)
[NCV8170BMX330TCG](#) [NCV8170AMX120TCG](#) [NCP706ABMX300TAG](#) [NCP153MX330180TCG](#) [NCP114BMX075TCG](#) [MC33269T-3.5G](#)
[CAT6243-ADJCMT5T](#) [TCR3DG33,LF](#) [TCR4DG35,LF](#) [TAR5S15U\(TE85L,F\)](#) [TAR5S18U\(TE85L,F\)](#) [TCR3UG19A,LF](#) [TCR4DG105,LF](#)
[MPQ2013AGG-5-P](#) [NCV8170AMX360TCG](#) [TLE4268GSXUMA2](#) [NCP715SQ15T2G](#) [MIC5317-3.0YD5-T5](#) [NCV563SQ18T1G](#)
[NCP715MX30TBG](#) [NCV8702MX25TCG](#) [NCV8170BXV120T2G](#) [MIC5317-1.2YD5-T5](#) [NCV8170AMX150TCG](#) [NCV8170BMX150TCG](#)
[AP2213D-3.3TRG1](#) [NCV8170BMX120TCG](#) [NCV8170BMX310TCG](#) [NCV8170BMX360TCG](#)