

1.7 Watt Audio Power Amplifier

Features

- Improved PSRR at 217 Hz & 1 KHz 60 dB
- Power output at 5.0V, 10%THD+N, 4 Ω (SOP8 package) 1.7W(typ.)
- Power output at 5.0V, 1% THD+N, 8 Ω 1.1 W (typ.)
- Ultra low shutdown current 0.1 uA (typ.)
- 2.2V – 5.5V operation
- Improved circuitry eliminates pop-click noise during turn-on and turn-off transitions
- No output coupling capacitors, snubber networks or bootstrap capacitors required
- Unity-gain stable
- External gain configuration capability
- Packages: MSOP8、SOP8

General Description

The BL6281G is a Class-AB audio power amplifier designed for mobile phone, MID and other portable communication devices. It is capable of delivering 1.1 watts of continuous average power to an 8 Ω BTL load with less than 1% distortion (THD+N) from a 5V_{DC} power supply.

The BL6281G was designed specifically to provide high quality output power with a minimal amount of external components. It does not require output coupling capacitors or bootstrap capacitors. And with ultra low shutdown current, the BL6281G is ideally suited for mobile phone, MID and other low voltage applications where minimal power consumption is a primary requirement.

With special pop-click eliminating circuit, the BL6281G provides perfect pop-click characteristic during turn-on and turn-off transitions.

The BL6281G is unity-gain stable and can be configured by external gain-setting resistors.

Applications

- MID
- Wireless handsets
- Portable electronic devices
- PDAs, Handheld computers

Order Information

Part Number	Package	MOQ
BL6281GMM	MSOP8	3000 pcs / Tape & Reel
BL6281GSO	SOP8	2500 pcs / Tape & Reel

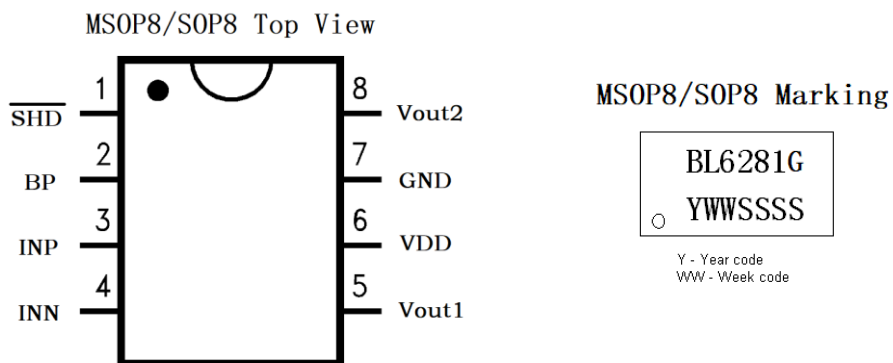
Pin Diagrams

Pin Description

No.	Pin Name	I/O	Description
1	$\overline{\text{SHD}}$	I	Shut-down Logical Control, '0' is active.
2	BP	I/O	Analog ground for inner OPAs. It's about a half of VDD.
3	INP	I	Positive Input
4	INN	I	Negative Input
5	Vout1	O	Negative BTL Output
6	VDD	I/O	Power Supply (2.2 – 5.5 V)
7	GND	I/O	Ground
8	Vout2	O	Positive BTL Output

Typical Application Circuit

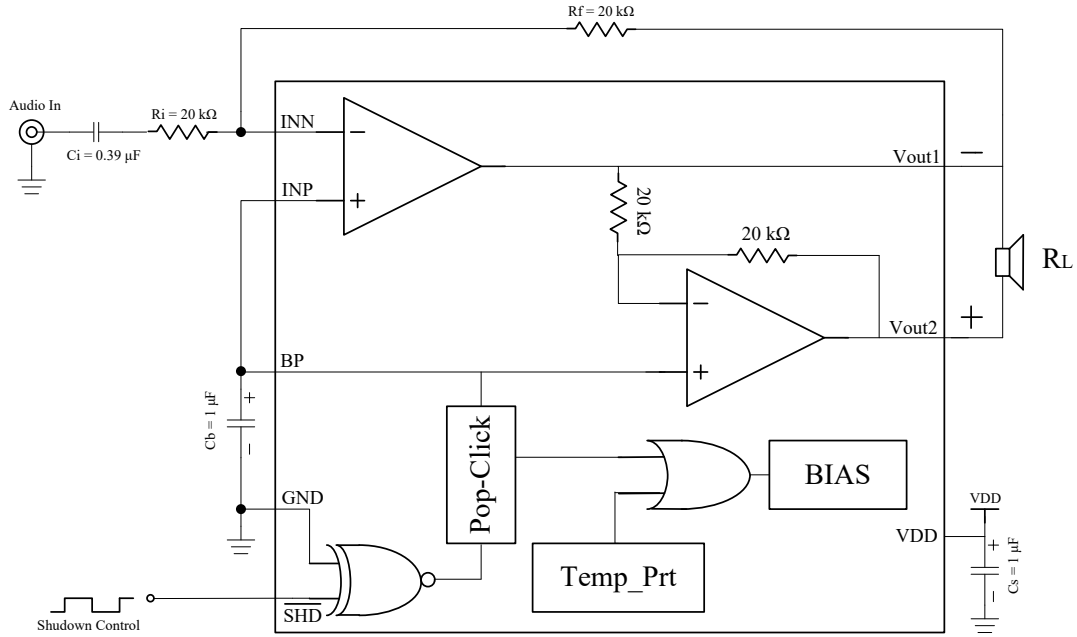

FIGURE 1. BL6281G Typical Application Circuit

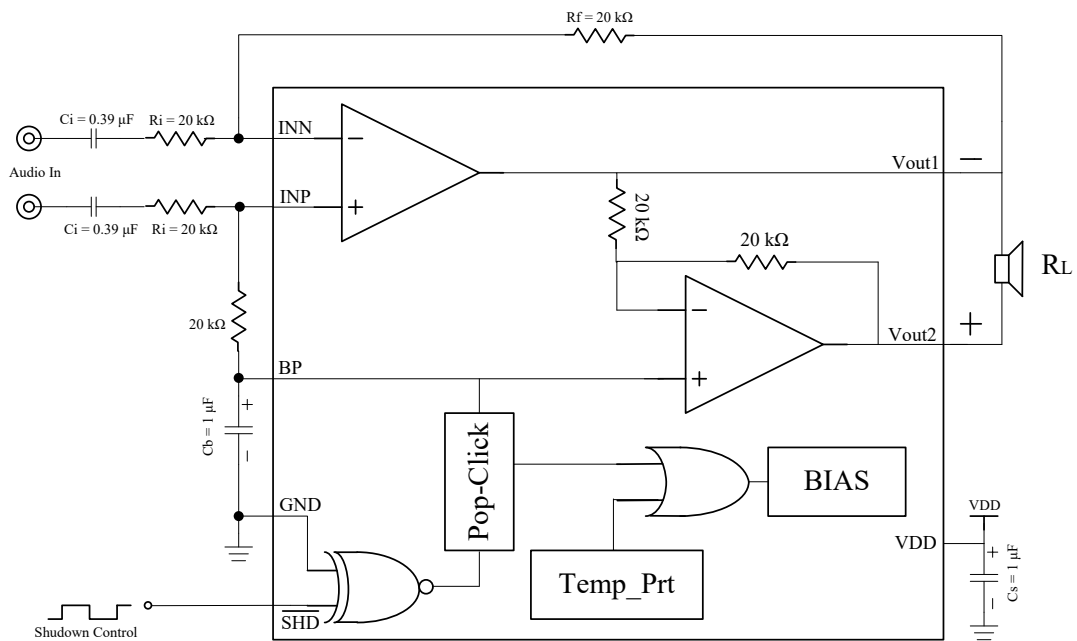

FIGURE 2. BL6281G Differential Amplifier Configuration

External Components Description

Components	Functional Description
Ri	Inverting input resistance which sets the closed-loop gain in conjunction with Rf. This resistor also forms a high pass filter with Ci at $f_c = 1/(2\pi R_i * C_i)$.
Ci	Input coupling capacitor which blocks the DC voltage at the amplifiers input terminates. Also creates a high-pass filter with Ri at $f_c = 1/(2\pi R_i * C_i)$.
Rf	Feedback resistance which sets the closed-loop gain in conjunction with Ri. The gain is $A_{VD} = 2 * (R_f / R_i)$.
Cs	Supply bypass capacitor which provides power supply filtering.
Cb	Bypass pin capacitor which provides half-supply filtering. Refer to the section.

Absolute Maximum Ratings

Supply Voltage	-0.3V to 6V
Input Voltage	-0.3V to VDD+0.3V
Power Dissipation	

See Dissipation Rating Table

Junction Temperature	-40°C to +150°C
Storage Temperature	-65°C to +150°C
Thermal Resistance	
$\theta_{JC}(\text{MSOP8})$	56°C/W
$\theta_{JA}(\text{MSOP8})$	190°C/W
$\theta_{JA}(\text{SOP8})$	184°C/W

Operating Ratings

Temperature Range	$-40^\circ\text{C} \leq T_A \leq 85^\circ\text{C}$
Supply Voltage	$2.2\text{V} \leq V_{DD} \leq 5.5\text{V}$

NOTE: Absolute Maximum Ratings indicate limits beyond which damage to the device may occur.
Operating Rating indicate conditions for which the device is functional, but do not guarantee specific performance limits.

Electrical Characteristics

The following specifications apply for the circuit shown in Figure 1, unless otherwise specified. Limits apply for $T_A = 25^\circ\text{C}$.

□ $V_{DD} = 5\text{V}$

Symbol	Parameter	Conditions	Spec			Units
			Min.	Typ.	Max.	
IDD	Quiescent Power Supply Current	$V_{IN} = 0\text{V}, 8\Omega \text{ Load}$		3.5	8	mA
		$V_{IN} = 0\text{V}, \text{ No Load}$		3	7	mA
ISD	Shutdown Current	$V_{IN}=0\text{V}, V_{SHD}=\text{GND}, \text{ No Load}$		0.1	2	uA
VSDIH	Shutdown Voltage Input High		1.3			V
VSDIL	Shutdown Voltage Input Low				0.8	V
VOS	Output Offset Voltage		-50	6	50	mV
THD+N	Total Harmonic Distortion+Noise	$P_o=0.5\text{Wrms}, f=1\text{KHz},$		0.05		%
PO	Output Power	$\text{THD+N} \leq 1\%, f=1\text{KHz},$	0.9	1.1		W

		8Ω Load				
PSRR	Power Supply Rejection Ratio	Input terminated with 10Ω, V _{DDRIPPLE} =0.2V _{P-P} , f=217Hz	50	60		dB
		Input terminated with 10Ω, V _{DDRIPPLE} =0.2V _{P-P} , f=1KHz	51	61		dB
TWU	Wake-up time			100		ms

□ V_{DD} = 3V

Symbol	Parameter	Conditions	Spec			Units
			Min.	Typ.	Max.	
I _{DD}	Quiescent Power Supply Current	V _{IN} = 0V, 8Ω Load		2.3	7	mA
		V _{IN} = 0V, No Load		1.9	6	mA
I _{SD}	Shutdown Current	V _{IN} =0V, V _{SHD} =GND, No Load		0.1	2	uA
V _{SDIH}	Shutdown Voltage Input High		1.0			V
V _{SDIL}	Shutdown Voltage Input Low				0.6	V
V _{OS}	Output Offset Voltage		-50	6	50	mV
THD+N	Total Harmonic Distortion+Noise	Po=0.25Wrms, f=1KHz,		0.06		%
P _O	Output Power	THD+N<=1%, f=1KHz, 8Ω Load		310		mW
PSRR	Power Supply Rejection Ratio	Input terminated with 10Ω, V _{DDRIPPLE} =0.2V _{P-P} , f=217Hz	53	65		dB
		Input terminated with 10Ω, V _{DDRIPPLE} =0.2V _{P-P} , f=1KHz	54	66		dB
TWU	Wake-up time			90		ms

□ V_{DD} = 2.6V

Symbol	Parameter	Conditions	Spec			Units
			Min.	Typ.	Max.	
I _{DD}	Quiescent Power Supply Current	V _{IN} = 0V, 8Ω Load		1.8		mA
		V _{IN} = 0V, No Load		1.5		mA
I _{SD}	Shutdown Current	V _{IN} =0V, V _{SHD} =GND, No Load		0.1		uA
V _{SDIH}	Shutdown Voltage Input High		1.0			V
V _{SDIL}	Shutdown Voltage Input Low				0.5	V
V _{OS}	Output Offset Voltage		-50	4	50	mV
THD+N	Total Harmonic Distortion+Noise	Po=0.15Wrms, f=1KHz,		0.06		%
P _O	Output Power	THD+N<=1%, f=1KHz, 8Ω Load		230		mW
PSRR	Power Supply Rejection Ratio	Input terminated with 10Ω, V _{DDRIPPLE} =0.2V _{P-P} , f=217Hz	52	64		dB
		Input terminated with 10Ω, V _{DDRIPPLE} =0.2V _{P-P} , f=1KHz	53	65		dB
TWU	Wake-up time			80		ms

Typical Performance Characteristics

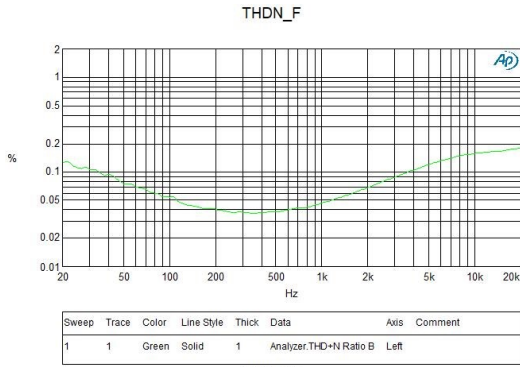

THDN vs Frequency
VDD=5V RL=8Ω PO=500 mW

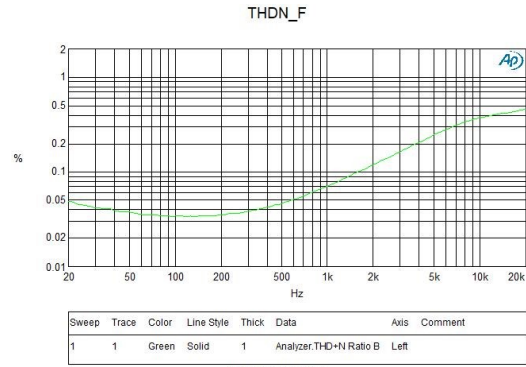

THDN vs Frequency
VDD=3V RL=8Ω PO=250mW

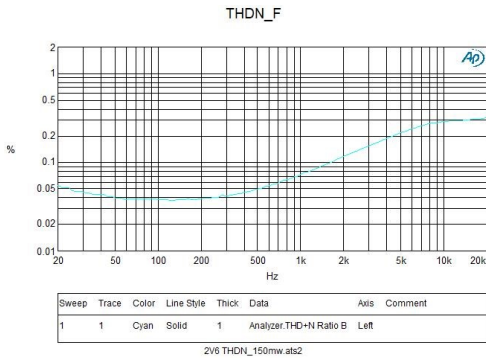

THDN vs Frequency
VDD=2.6V RL=8Ω PO=150 mW

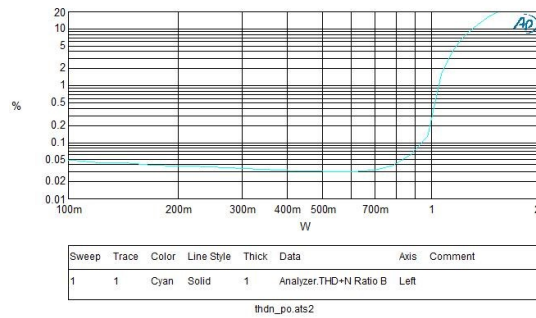

THDN vs Output Power
VDD=5V RL=8Ω F=1KHz

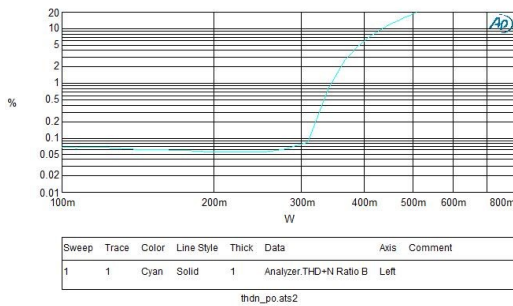

THDN vs Output Power
VDD=3V RL=8Ω F=1KHz

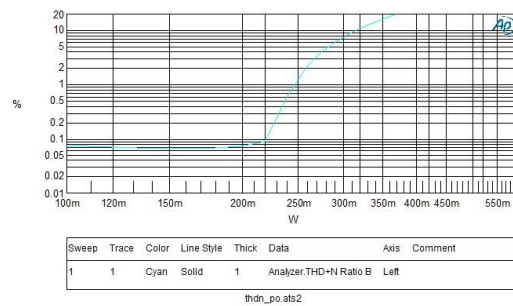

THDN vs Output Power
VDD=2.6V RL=8Ω F=1KHz

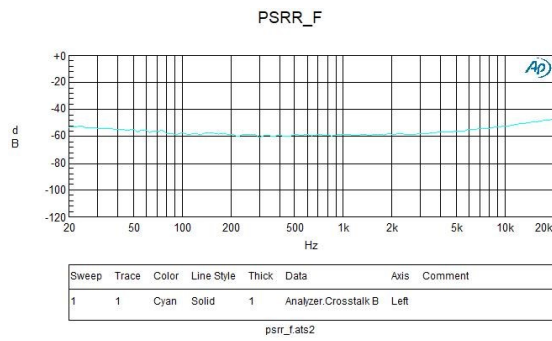

PSRR vs Frequency
VDD=5V RL=8Ω



PSRR vs Frequency
VDD=3V RL=8Ω

Package Dimensions

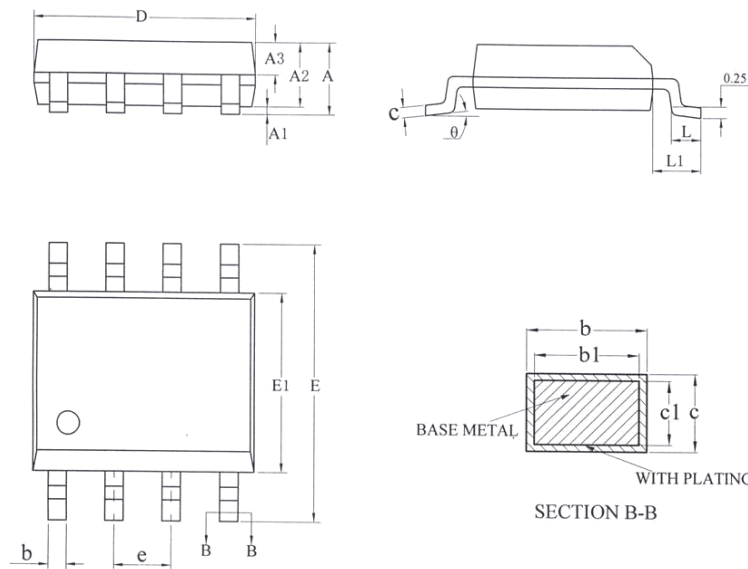
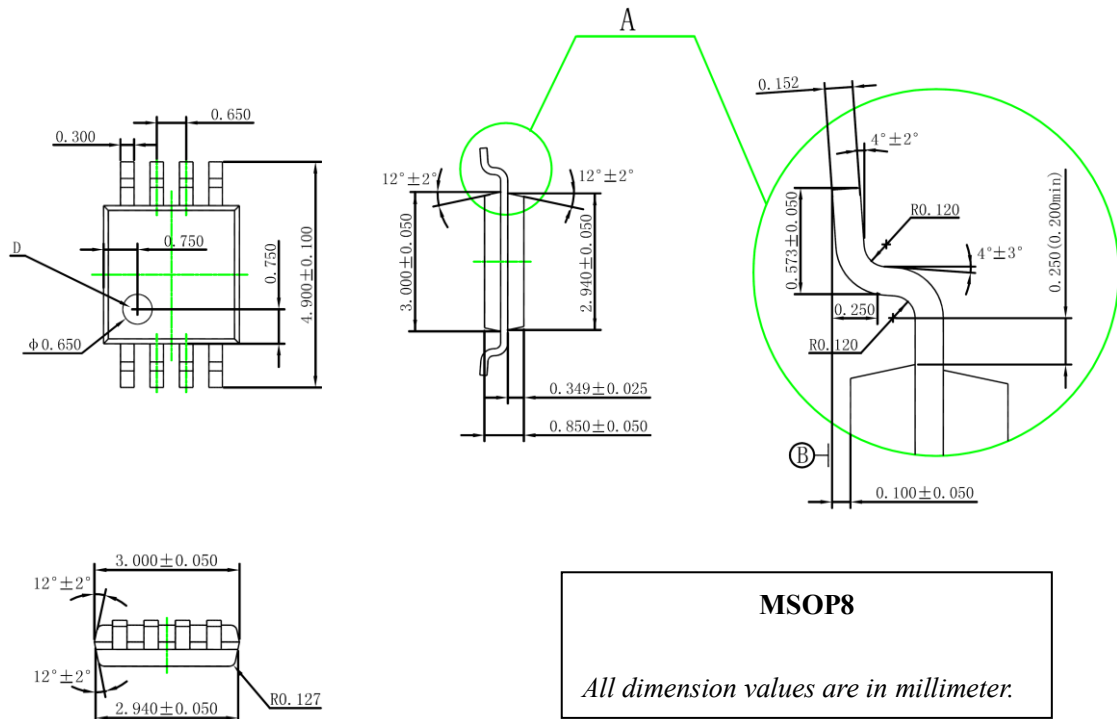

SYMBOL	MILLIMETER		
	MIN	NOM	MAX
A	—	—	1.77
A1	0.08	0.18	0.28
A2	1.20	1.40	1.60
A3	0.55	0.65	0.75
b	0.39	—	0.48
b1	0.38	0.41	0.43
c	0.21	—	0.26
c1	0.19	0.20	0.21
D	4.70	4.90	5.10
E	5.80	6.00	6.20
E1	3.70	3.90	4.10
e	1.27BSC		
L	0.50	0.65	0.80
L1	1.05BSC		
θ	0	—	8°

SOP8

X-ON Electronics

Largest Supplier of Electrical and Electronic Components

Click to view similar products for [Audio Amplifiers](#) category:

Click to view products by [Belling](#) manufacturer:

Other Similar products are found below :

[LV47002P-E](#) [AZ386MTR-E1](#) [NCP2890AFCT2G](#) [LC706200CM](#) [IS31AP4915A-QFLS2-TR](#) [TDA1591T](#) [TS2012EIJT](#) [NCP2809BMUTXG](#)
[NJW1157BFC2](#) [IS31AP4996-GRLS2-TR](#) [NCP2823BFCT1G](#) [BD88420GUL-E2](#) [LA4450L-E](#) [IS31AP2036A-CLS2-TR](#) [TDA7563ASMTR](#)
[BD88400GUL-E2](#) [BD88200GUL-E2](#) [SABRE9601K](#) [THAT1646W16-U](#) [PAM8965ZLA40-13](#) [TSDP10XX1NLGXZBX](#)
[TSDP11XX1NGBIZBX](#) [TSDP10XX1NGBIZBX](#) [NJM4580CV-TE1](#) [TPA3223DDVR](#) [LV4910T-MPB-E](#) [NCP2890AFCT2](#) [NCV2211DR2G](#)
[SCY99091FCT2G](#) [COS6112](#) [LM4890SS](#) [LM4871](#) [NS4890C](#) [AW8010BFCR](#) [COS4812](#) [MC34018M/TR](#) [LM4890MM/TR](#) [ME5301ASPG](#)
[LM386M-1](#) [TAS5720MRSMR](#) [BL6281GMM](#) [BL6281GSO-R](#) [BL6281GSO](#) [CS3818EO](#) [CS3817BEO](#) [CS3815EO](#) [LM4861BM/TR](#)
[LM386BN-1](#) [TDA2822N](#) [MC34118M/TR](#)