

2A Low Consumption Linear Regulator

DESCRIPTION

BL8072 is a series of low power consumption, low dropout voltage regulator with a typical dropout voltage of 1.0V at 2A load current.

BL8072 can provide output value in the range of 1.2V~5.0V in 0.1V steps. It also can customized on command.

Other than every voltage version can be used as an adjustable voltage version, with which desired voltage can be achieved by setting the values of two external resistors of the application circuitry.

BL8072 has well load transient response and good temperature characteristic, And it uses trimming technique to guarantee output voltage accuracy within $\pm 2\%$.

BL8072 series is available in standard packages of SOT-223 and TO-252.

FEATURES

- Low Power Consumption: 3.0uA (Typ.)
- Maximum output current : 2A
- Maximum input voltage: 18V
- Line regulation: 0.2% (Typical)
- Output Voltage Range: 1.2V~5.0V (customized on command in 0.1V steps)
- Highly Accurate: $\pm 2\%$ ($\pm 1\%$ customized)
- Typical Dropout Voltage: 850mV@1.5A (Vout=3.3V)
- Operation environment Temperature: $-40^{\circ}\text{C}\sim 85^{\circ}\text{C}$

APPLICATIONS

- Battery Charger
- Battery Powered equipment
- Post Regulators for Switching Supplies
- Reference Voltage Source Regulation after Switching Power

TYPICAL APPLICATION

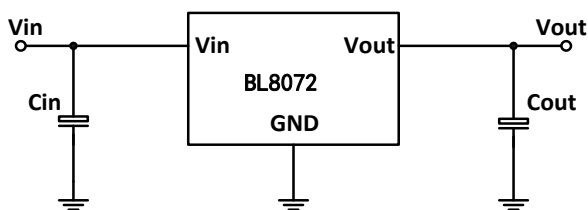
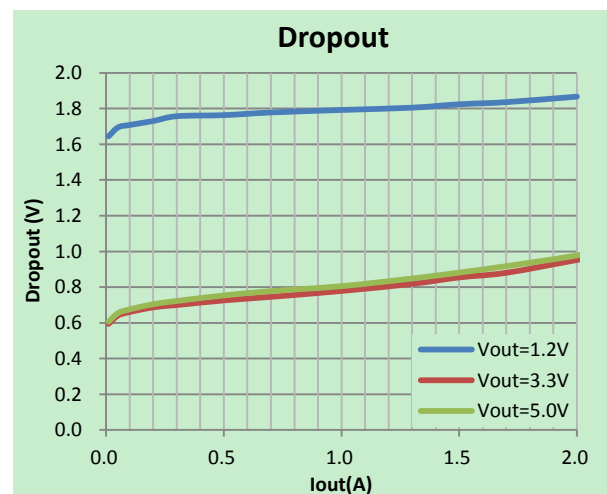

Fig1. BL8072 fixed voltage application circuit

Note: Input capacitor ($C_{in}=1\mu\text{F}$) and Output capacitor ($C_{out}=1\mu\text{F}$) are recommended in all application circuit. ceramic capacitor is recommended.

ELECTRICAL CHARACTERISTICS



ORDERING INFORMATION

BL8072 1 2 3 4 5

Code	Description
1	Temperature&RoHS: C: -40~85°C, Pb Free RoHS Std.
2	Package type: L: SOT-223 O:TO-252
3	Packing type: TR: Tape&Reel (Standard)
4	Output voltage: e.g. 18=1.8V 33=3.3V 50=5.0V
5	Voltage accuracy: Blank(default):±2% 1: ±1%

ABSOLUTE MAXIMUM RATING

Parameter	Value
Max Input Voltage	20V
Operating Junction Temperature(Tj)	125°C
Ambient Temperature(Ta)	-40°C -85°C
Package	SOT-223
Thermal Resistance	TO-252
Storage Temperature(Ts)	-40°C -150°C
Lead Temperature & Time	260°C,10S

Note:

Exceed these limits to damage to the device.
Exposure to absolute maximum rating conditions may affect device reliability.

RECOMMENDED WORK CONDITIONS

Parameter	Value
Input Voltage Range	Max.18V
Ambient Temperature	-40°C -85°C

PIN CONFIGURATION

Product Classification	BL8072CLTR□□
JJ: Product Code	
XX: Output Voltage	
LL: Lot No.	
YYWW: Date Code	
Product Classification	BL8072COTR□□
JJ: Product Code	
XX: Output Voltage	
LL: Lot No.	
YYWW: Date Code	

XX: Output voltage code, e.g. 12=1.2V, 25=2.5V, 33=3.3V;
YY: The Year of manufacturing, "11" stands for year 2011, "12" stands for year 2012, and "28" stands for year 2028.
WW: The week of manufacturing. "01" stands for week 1, "02" stands for week 02, "52" stands for week 52.

ELECTRICAL CHARACTERISTICS

(Test Conditions: $C_{in}=1\mu F$, $C_{out}=1\mu F$, $T_A=25\text{ }^\circ\text{C}$, Unless Otherwise Specified)

Symbol	Parameter	Conditions		Min	Typ	Max	Unit
V_{in}	Input Voltage					18	V
V_{out}	Output Voltage			$V_{out} \times 0.98$		$V_{out} \times 1.02$	V
$I_{out(Max.)}$	Maximum Output Current	$V_{in}-V_{out}=1.9V$	$V_{out} < 1.5V$	2			A
		$V_{in}-V_{out}=1.5V$	$1.5V \leq V_{out} < 2.0V$				
		$V_{in}-V_{out}=1V$	$V_{out} \geq 2.0V$				
Dropout Voltage	Input-Output Voltage Differential (note 3)	$I_{out} \leq 1.5A$	$V_{out} < 1.5V$		1600	1800	mV
			$1.5V \leq V_{out} < 2.0V$		1200	1400	
			$V_{out} \geq 2.0V$		850	950	
$\frac{\Delta V_{out}}{\Delta V_{in} \cdot V_{out}}$	Line Regulation (note 1)	$I_{out}=10mA$ Set $V_{out}+1V \leq V_{in} \leq 18V$			0.1	0.3	%/V
ΔV_{out}	Load Regulation (note 1,2)	$1mA \leq I_{out} \leq 1.5A$	$V_{out} < 1.5V$		40	60	mV
			$1.5V \leq V_{out} < 2.0V$		20	40	
			$V_{out} \geq 2.0V$		10	30	
I_q	Quiescent Current	$V_{in} = \text{Set } V_{out} + 1V$			3.0	5.0	μA
$\frac{\Delta V_{out}}{\Delta T \cdot V_{out}}$	Output Voltage Temperature Coefficient	$I_{out}=100mA$			200		ppm/ $^\circ C$
θ_{JC}	Thermal Resistance junction to case	SOT-223			20		$^\circ C / W$
		TO-252			12		

Note1: Line Regulation and Load Regulation in Table1 are tested under constant junction temperature.

Note2: When load current varies between $0 \sim 2A$ and $V_{in}-V_{out}$ ranges from $1V \sim 18V$ at constant junction temperature, the parameter is satisfied the criterion in table.

Note3: Dropout Voltage is the voltage difference between the input and output pin when the input voltage is minimum to maintain the lowest spec output voltage.

BLOCK DIAGRAM

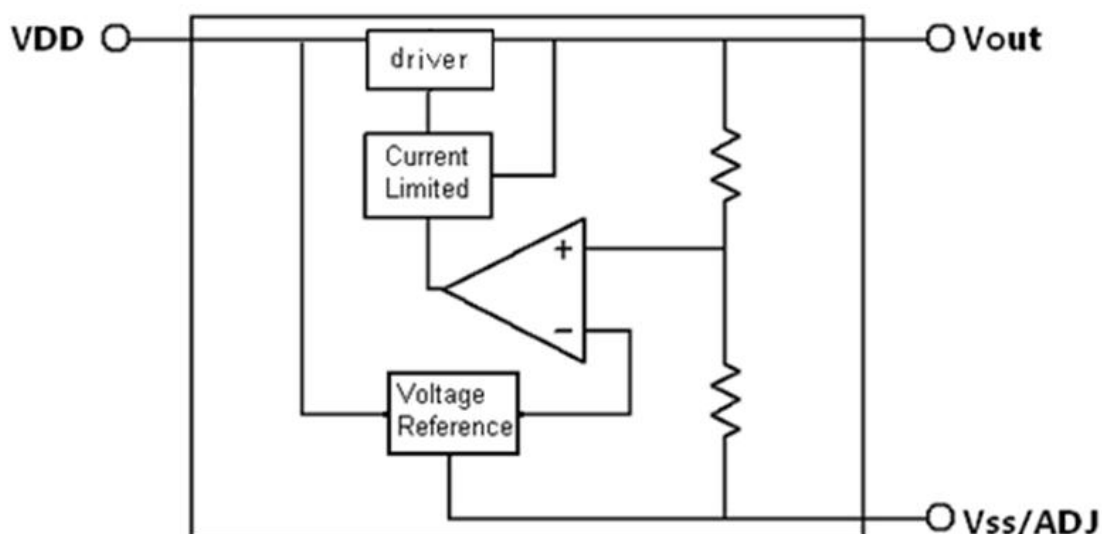

DETAILED DESCRIPTION

BL8072 is a series of low dropout voltage and low power consumption regulator. Its application circuitry requires minimum number of external components. Both fixed voltage and adjustable voltage application circuits need input and output capacitors to assure output voltage stability. Any desired output voltage from fixed voltage to 18V can be achieved by assigning proper values to two external resistors in its application circuitry (as shown in Fig.3, as R1, R2 are the two external resistors.).

BL8072 uses trimming technique to assure the accuracy of output value within $\pm 2\%$, at the same time, temperature compensation is elaborately considered in this chip, which makes BL8072's temperature coefficient within 100ppm/ $^{\circ}\text{C}$.

TYPICAL APPLICATION

BL8072 has fixed voltage and adjustable voltage application mode, Fig.4 shows their typical application circuitry.

A 1 μF ceramic capacitor connected between input and GND as bypass capacitor and a 1 μF ceramic capacitor between output and GND are recommended for all application.

Using a bypass capacitor (C_{Adj}) between the adjust terminal and ground can improve ripple rejection. The bypass capacitor prevents ripple from being amplified in case the output voltage is increased. The impedance of C_{Adj} should be less than the resistance of R_1 to prevent ripple from being amplified at any frequency. As R_1 is normally in the range of 1K Ω ~10K Ω , the value of C_{Adj} should satisfy the following condition:

$$1/(2\pi * \text{Frequency}_{\text{Ripple}} * C_{\text{adj}}) < R_1$$

A 0.1 μF ceramic capacitor is recommended.

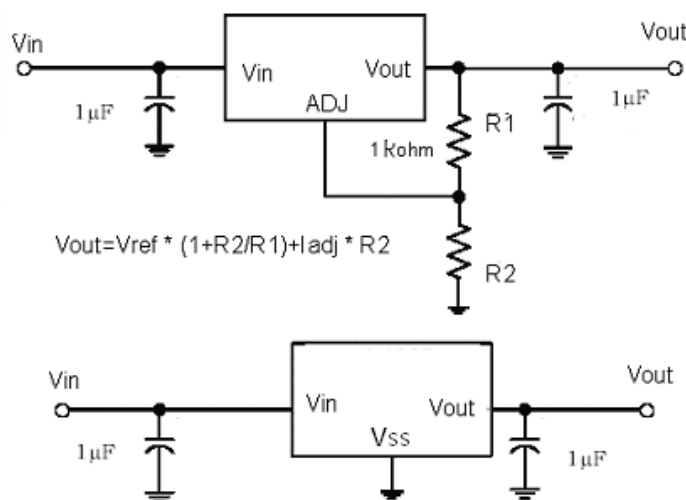

Fig 3. Typical Application of BL8072

EXPLANATION

The output voltage of adjustable application satisfies this followed equation:

$$V_{\text{out}} = V_{\text{Ref}} \times (1 + R_2/R_1) + I_{\text{Adj}} \times R_2.$$

The second term $I_{\text{Adj}} \times R_2$ can be ignored since the adjustable pin current I_{Adj} ($\sim 2\mu\text{A}$) is much less than the current through R_1 ($\sim 1\text{mA}$).

The value of R_1 is preferred in the range of 1K Ω ~10K Ω and the value of V_{Ref} is the output voltage of typical fixed voltage application circuit.

TYPICAL PERFORMANCE CHARACTERISTICS

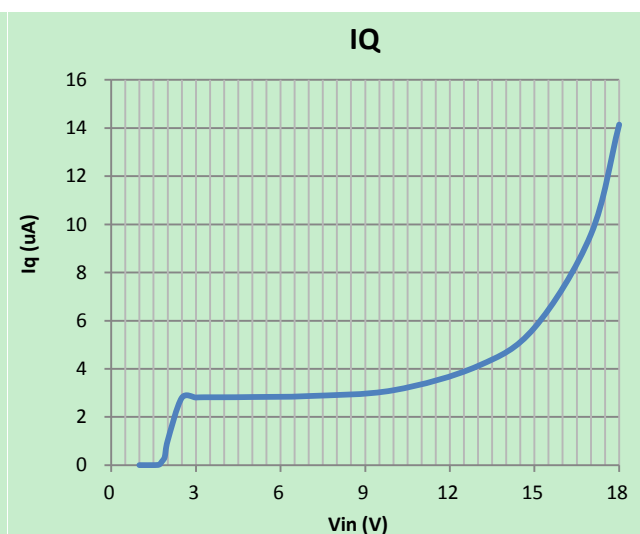
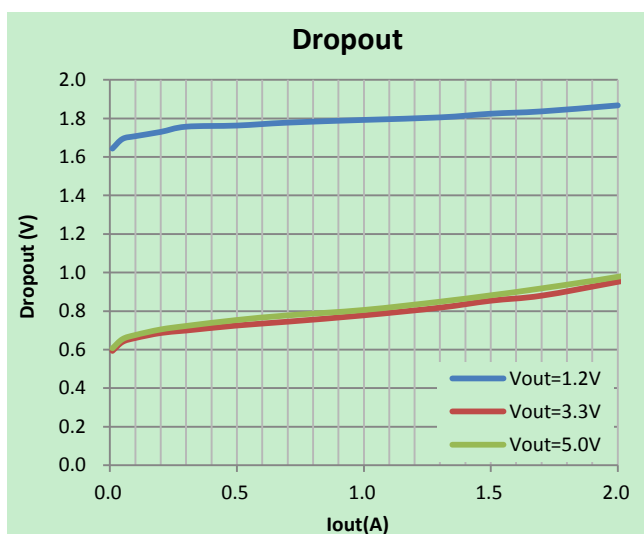
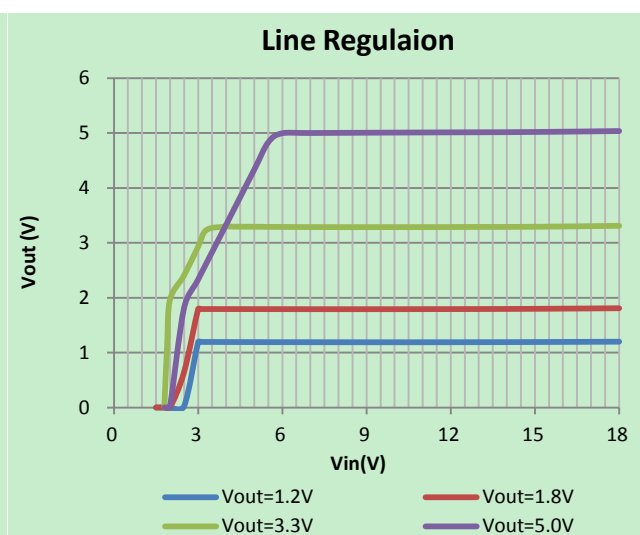
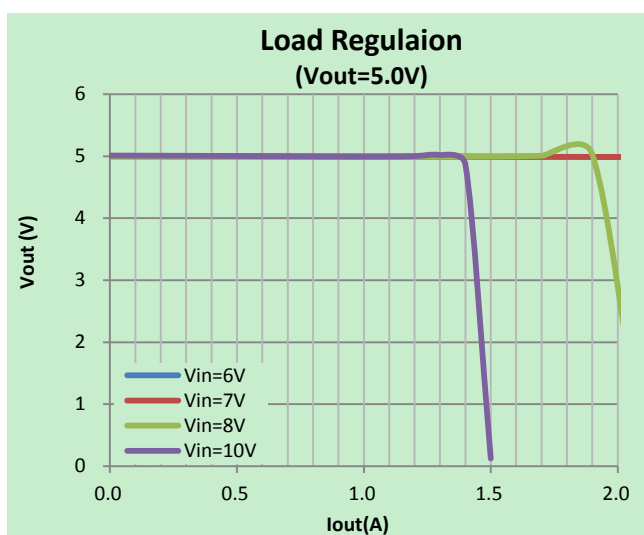
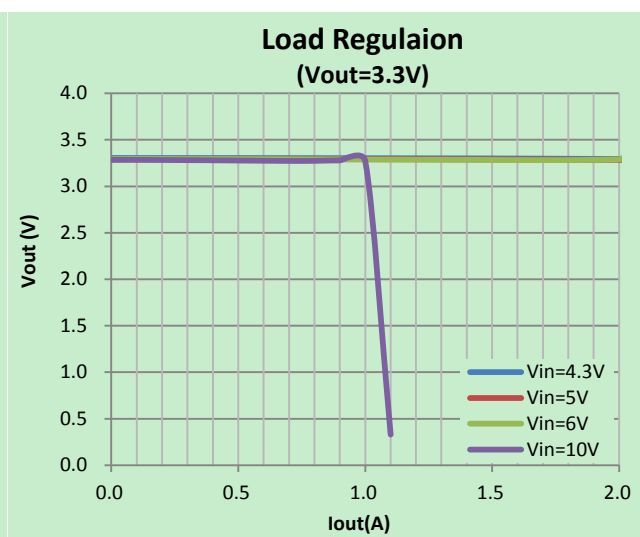
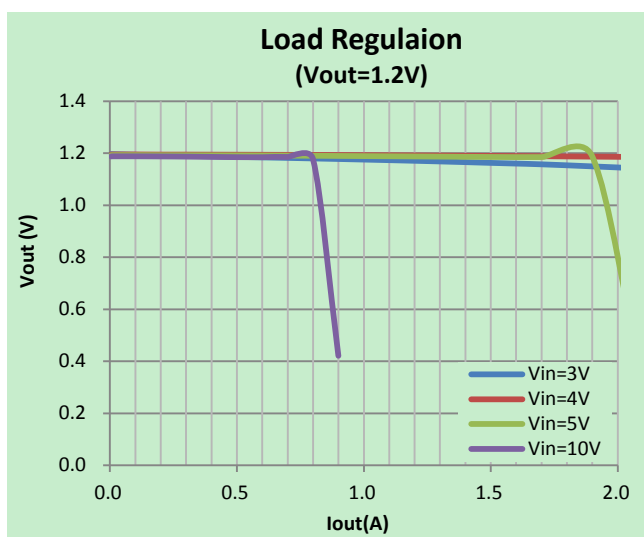

Line Transient Response

$I_{out}=100mA, V_{in}=3.3V \text{ to } 4.3V$
(Orange: V_{in} , Green: V_{out})

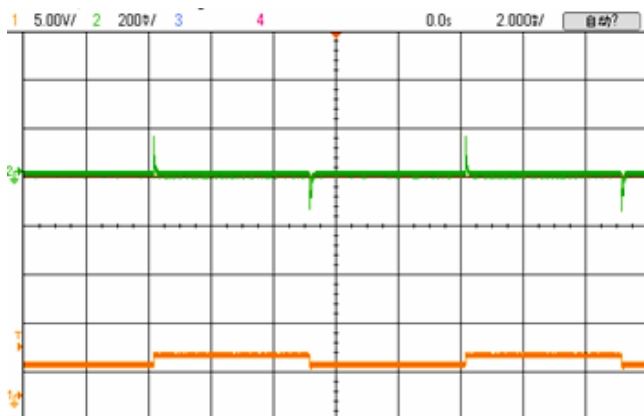

Load Transient Response

$V_{in}=3.3V, I_{out}=0.1A \text{ to } 1A$
(Pink: I_{out} , Green: V_{out})

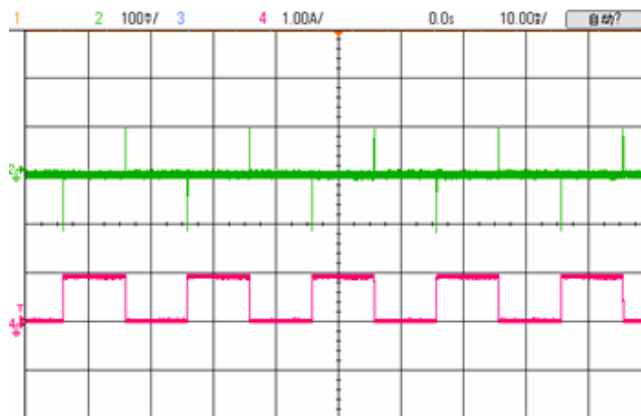

PACKAGE LINE

Package	TO-252	Devices per reel	2500	Unit	mm
---------	--------	------------------	------	------	----

Package specification:

SYMBOL	MIN	NOM	MAX
A	2.20	2.30	2.38
A1	0	-	0.10
A2	0.90	1.00	1.10
b	0.77	-	0.89
b1	0.76	0.81	0.86
b2	0.77	-	1.10
b3	5.23	5.33	5.43
c	0.47	-	0.60
c1	0.46	0.51	0.56
c2	0.47	-	0.60
D	6.00	6.10	6.20
D1	5.25	-	-
E	6.50	6.60	6.70
E1	4.70	-	-
e	2.28BSC		
H	9.80	10.10	10.40
L	1.40	1.50	1.70
L1	2.90REF		
L2	0.51BSC		
L3	0.90	-	1.25
L5	0.90	-	1.50
L6	1.80REF		
theta	0°	-	8°
theta 1	3°	5°	7°
theta 2	1°	3°	5°

BASE METAL PLATING

SECTION C-C

BL8072

Package	SOT-223	Devices per reel	2500	Unit	mm
---------	---------	------------------	------	------	----

Package specification:

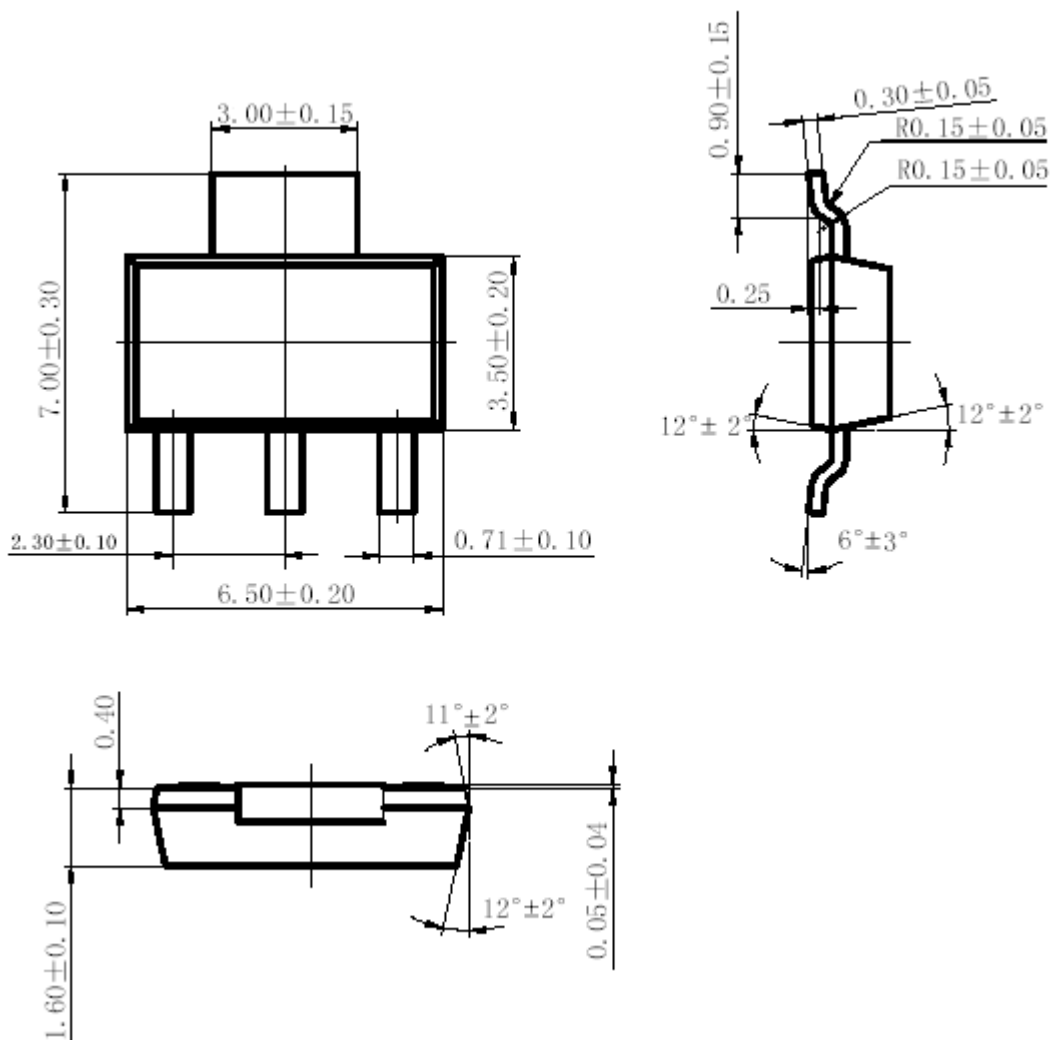

X-ON Electronics

Largest Supplier of Electrical and Electronic Components

Click to view similar products for [LDO Voltage Regulators](#) category:

Click to view products by [Belling](#) manufacturer:

Other Similar products are found below :

[AP7363-SP-13](#) [L79M05TL-E](#) [AP7362-HA-7](#) [PT7M8202B12TA5EX](#) [TCR3DF185,LM\(CT](#) [TCR3DF45,LM\(CT](#) [TLE4473G V52](#) [059985X](#)
[NCP4687DH15T1G](#) [701326R](#) [NCV8170AXV250T2G](#) [AP7315-25W5-7](#) [AP2111H-1.2TRG1](#) [ZLDO1117QK50TC](#) [AZ1117ID-ADJTRG1](#)
[TCR3DG12,LF](#) [MIC5514-3.3YMT-T5](#) [SCD7912BTG](#) [NCP154MX180270TAG](#) [SCD33269T-5.0G](#) [NCV8170BXV330T2G](#)
[NCV8170BMX330TCG](#) [NCV8170AMX120TCG](#) [NCP706ABMX300TAG](#) [NCP153MX330180TCG](#) [NCP114BMX075TCG](#) [MC33269T-3.5G](#)
[CAT6243-ADJCMT5T](#) [TCR3DG33,LF](#) [TCR4DG35,LF](#) [TAR5S15U\(TE85L,F\)](#) [TAR5S18U\(TE85L,F\)](#) [TCR3UG19A,LF](#) [TCR4DG105,LF](#)
[MPQ2013AGG-5-P](#) [NCV8170AMX360TCG](#) [TLE4268GSXUMA2](#) [NCP715SQ15T2G](#) [MIC5317-3.0YD5-T5](#) [NCV563SQ18T1G](#)
[NCP715MX30TBG](#) [NCV8702MX25TCG](#) [NCV8170BXV120T2G](#) [MIC5317-1.2YD5-T5](#) [NCV8170AMX150TCG](#) [NCV8170BMX150TCG](#)
[AP2213D-3.3TRG1](#) [NCV8170BMX120TCG](#) [NCV8170BMX310TCG](#) [NCV8170BMX360TCG](#)