

Features:

- Low Power Consumption: 3.0uA (Typ.)
- Maximum Output Current: 250mA
- Small Dropout Voltage:
 170mV@100mA (Vout=3.0V)
 400mV@250mA (Vout=3.0V)
- Input Voltage Range: 1.5V~10V
- Output Voltage Range: 1.2V~6.0V
 (customized on command in 0.1V steps)
- Highly Accurate: $\pm 2\%$ ($\pm 1\%$ customized)
- Output Current Limit

Applications:

- Battery Powered equipment
- Power Management of MP3、PDA、DSC、Mouse、PS2 Games
- Reference Voltage Source
- Regulation after Switching Power

Outline:

BL8503 series is a group of positive voltage output, low power consumption, low dropout voltage, three terminal regulator. It can provide 250mA output current when input / output voltage differential drops to 400mV (Vin =4.0V、Vout=3.0V)。The very low power consumption of BL8503 (Iq=3.0uA) can greatly improve natural life of batteries.

BL8503 can provide output value in the range of 1.2V~6.0V in 0.1V steps. It also can customized on command.

BL8503 includes high accuracy voltage reference, error amplifier, current limit circuit and output driver module.

BL8503 has well load transient response and good temperature characteristic, which can assure the stability of chip and power system. And it uses trimming technique to guarantee output voltage accuracy within $\pm 2\%$.

BL8503 is available in SOT-89-3、SOT-23-3、TO-92 packages which is lead free, it also can available in these packages with lead.

BL8503 Typical Application Circuit

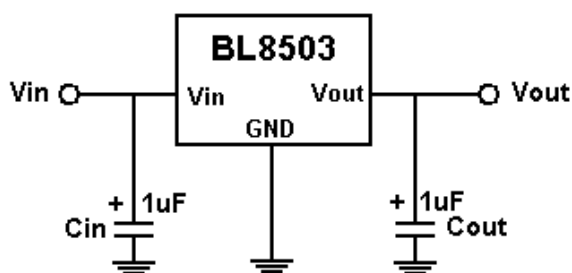

Application hints:



NOTE1: Input capacitor (Cin=1uF) is recommended in all application circuit. Tantalum capacitor is recommended.

NOTE2: Output capacitor (Cout=1uF) is recommended in all application to assure the stability of circuit. Tantalum capacitor is recommended.

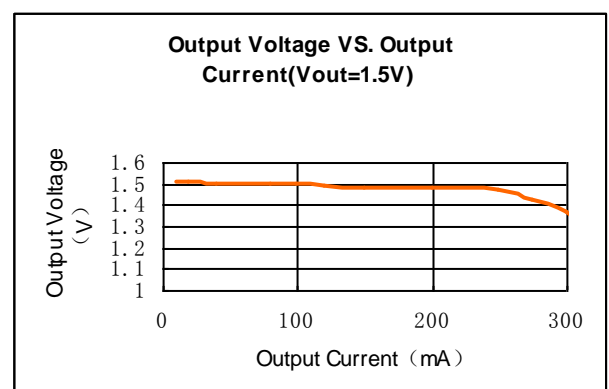
BL8503 Typical Performance Characteristic:

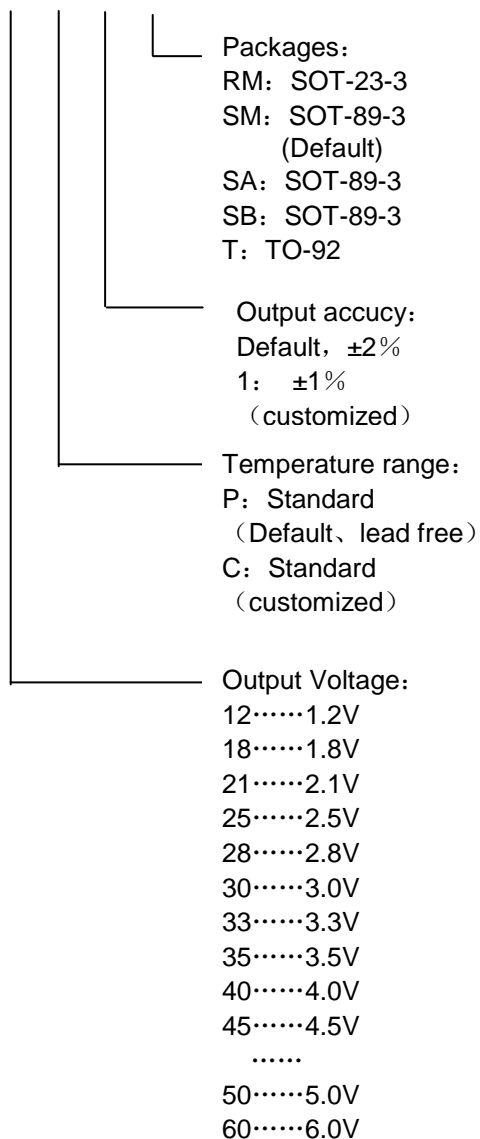

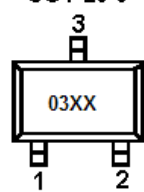
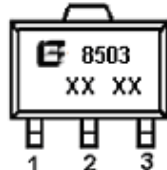
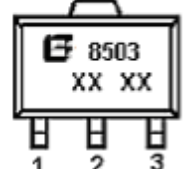
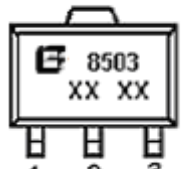
Selection Guide:
BL8503-XX X X X

Pin Assignment:

Product Classification	Pin Configuration
BL8503-□□□PRM	SOT-23-3 
BL8503-□□□PSM	SOT-89-3 
BL8503-□□□PSA	SOT-89-3 
BL8503-□□□PSB	SOT-89-3 
BL8503-□□□PT	TO-92 

Pin Description:

Pin number					PIN Name	Function
SOT-23-3	SOT-89-3 (SM)	SOT-89-3 (SA)	SOT-89-3 (SB)	TO-92		
1	1	1	2	1	Vss	Ground
3	2	3	3	2	Vin	Supply voltage input
2	3	2	1	3	Vout	Output Voltage

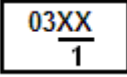
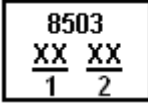
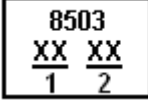
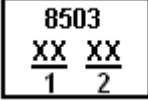
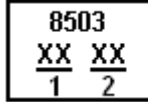
Product Classification:

Product Name	Output Voltage	Package Type	Package Marking
BL8503-12PRM	1.2V	SOT-23-3	 1 Output voltage
BL8503-15PRM	1.5V	SOT-23-3	
BL8503-21PRM	2.1V	SOT-23-3	
BL8503-25PRM	2.5V	SOT-23-3	
BL8503-30PRM	3.0V	SOT-23-3	
-----	-----	SOT-23-3	
BL8503-50PRM	5.0V	SOT-23-3	 1 Output voltage 2 Lot No.
BL8503-12PSM	1.2V	SOT-89-3	
BL8503-15PSM	1.5V	SOT-89-3	
BL8503-21PSM	2.1V	SOT-89-3	
BL8503-25PSM	2.5V	SOT-89-3	
BL8503-30PSM	3.0V	SOT-89-3	
-----	-----	SOT-89-3	
BL8503-50PSM	5.0V	SOT-89-3	 1 Output voltage 2 Lot No.
BL8503-12PSA	1.2V	SOT-89-3	
BL8503-15PSA	1.5V	SOT-89-3	
BL8503-21PSA	2.1V	SOT-89-3	
BL8503-25PSA	2.5V	SOT-89-3	
BL8503-30PSA	3.0V	SOT-89-3	
-----	-----	SOT-89-3	
BL8503-50PSA	5.0V	SOT-89-3	 1 Output voltage 2 Lot No.
BL8503-12PSB	1.2V	SOT-89-3	
BL8503-15PSB	1.5V	SOT-89-3	
BL8503-21PSB	2.1V	SOT-89-3	
BL8503-25PSB	2.5V	SOT-89-3	
BL8503-30PSB	3.0V	SOT-89-3	
-----	-----	SOT-89-3	
BL8503-50PSB	5.0V	SOT-89-3	 1 Output voltage 2 Lot No.
BL8503-12PT	1.2V	TO-92	
BL8503-15PT	1.5V	TO-92	
BL8503-21PT	2.1V	TO-92	
BL8503-25PT	2.5V	TO-92	
BL8503-30PT	3.0V	TO-92	
-----	-----	TO-92	
BL8503-50PT	5.0V	TO-92	

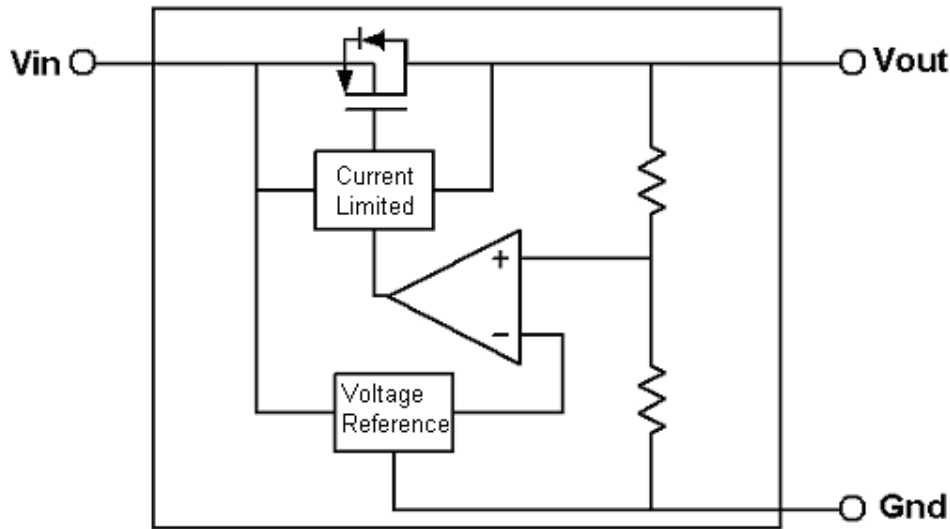
Block Diagram:

Absolute Maximum Ratings:

Max input voltage	-----	10V
Junction Temperature (T _J)	-----	125°C
Ambient Temperature(T _A)	-----	-40°C~85°C
Power Dissipation		
SOT-23-3	-----	0.15W
SOT-23-5	-----	0.25W
SOT-89-3	-----	0.5W
Storage Temperature(T _s)	-----	-45°C~150°C
Lead Temperature and Time	-----	260°C,10S

Recommended Work Conditions:

Item	Min	Recommended	Max	unit
Input Voltage Range			8	V
Ambient Temperature	-40		+125	°C

Electrical Characteristics:

(Test Conditions: C_{in}=1uF,C_{out}=1uF,T_A=25°C, unless otherwise specified.)

BL8503-1.5V

Symbol	Parameter	Conditions	Min	Typ	Max	Units
V _{in}	Input Voltage				8	V
V _{out}	Output Voltage		1.47	1.5	1.53	V
I _{out(Max.)}	Maximum Output Current	V _{in} =2.5V,V _{out} >1.47	250			mA
Dropout Voltage	Input-Output Voltage Differential	I _{out} =100mA		270	400	mV
$\frac{\Delta V_{out}}{\Delta V_{in} \cdot V_{out}}$	Line Regulation	I _{out} =40mA 1.6V≤V _{in} ≤8V		0.2	0.3	%/V
ΔV_{out}	Load Regulation	V _{in} =2.5V 1mA≤I _{out} ≤100mA		20	40	mV
I _q	Quiescent Current	V _{in} =2.5V		3.0	5.0	uA

$\frac{\Delta V_{out}}{\Delta T \cdot V_{out}}$	Output Voltage Temperature Coefficient	$I_{out}=10mA$		50		ppm/°C
---	--	----------------	--	----	--	--------

BL8503-1.8V

Symbol	Parameter	Conditions	Min	Typ	Max	Units
V_{in}	Input Voltage				8	V
V_{out}	Output Voltage		1.764	1.8	1.836	V
$I_{out(Max.)}$	Maximum Output Current	$V_{in}=2.8V, V_{out}>1.764$	250			mA
Dropout Voltage	Input-Output Voltage Differential	$I_{out}=100mA$		270	400	mV
$\frac{\Delta V_{out}}{\Delta V_{in} \cdot V_{out}}$	Line Regulation	$I_{out}=40mA$ $2V \leq V_{in} \leq 8V$		0.2	0.3	%/V
ΔV_{out}	Load Regulation	$V_{in}=2.8V$ $1mA \leq I_{out} \leq 100mA$		20	40	mV
I_q	Quiescent Current	$V_{in}=2.8V$		3.0	5.0	uA
$\frac{\Delta V_{out}}{\Delta T \cdot V_{out}}$	Output Voltage Temperature Coefficient	$I_{out}=10mA$		50		ppm/°C

BL8503-2.8V

Symbol	Parameter	Conditions	Min	Typ	Max	Units
V_{in}	Input Voltage				8	V
V_{out}	Output Voltage		2.744	2.8	2.856	V
$I_{out(Max.)}$	Maximum Output Current	$V_{in}=4V, V_{out}>2.744V$	250			mA
Dropout Voltage	Input-Output Voltage Differential	$I_{out}=100mA$		170	300	mV
		$I_{out}=200mA$		320	500	
$\frac{\Delta V_{out}}{\Delta V_{in} \cdot V_{out}}$	Line Regulation	$I_{out}=40mA$ $3V \leq V_{in} \leq 8V$		0.2	0.3	%/V
ΔV_{out}	Load Regulation	$V_{in}=3.8V$ $1mA \leq I_{out} \leq 100mA$		20	40	mV
I_q	Quiescent Current	$V_{in}=3.8V$		3.0	5.0	uA
$\frac{\Delta V_{out}}{\Delta T \cdot V_{out}}$	Output Voltage Temperature Coefficient	$I_{out}=10mA$		50		ppm/°C

BL8503-3.0V

Symbol	Parameter	Conditions	Min	Typ	Max	Units
V_{in}	Input Voltage				8	V
V_{out}	Output Voltage		2.94	3.0	3.06	V
$I_{out(Max.)}$	Maximum Output Current	$V_{in}=4V, V_{out}>2.94V$	250			mA
Dropout Voltage	Input-Output Voltage Differential	$I_{out}=100mA$		170	300	mV
		$I_{out}=200mA$		320	500	
$\frac{\Delta V_{out}}{\Delta V_{in} \cdot V_{out}}$	Line Regulation	$I_{out}=40mA$ $3.2V \leq V_{in} \leq 8V$		0.2	0.3	%/V

ΔV_{out}	Load Regulation	$V_{in}=4.0V$ $1mA \leq I_{out} \leq 100mA$		20	40	mV
I_q	Quiescent Current	$V_{in}=4V$		3.0	5.0	μA
$\frac{\Delta V_{out}}{\Delta T \cdot V_{out}}$	Output Voltage Temperature Coefficient	$I_{out}=10mA$		50		ppm/ $^{\circ}C$

BL8503-5.0V

Symbol	Parameter	Conditions	Min	Typ	Max	Units
V_{in}	Input Voltage				8	V
V_{out}	Output Voltage		4.9	5.0	5.1	V
$I_{out}(\text{Max.})$	Maximum Output Current	$V_{in}=6V, V_{out}>4.9V$	250			mA
Dropout Voltage	Input-Output Voltage Differential	$I_{out}=100mA$		170	300	mV
		$I_{out}=200mA$		320	500	
$\frac{\Delta V_{out}}{\Delta V_{in} \cdot V_{out}}$	Line Regulation	$I_{out}=40mA$ $5.2V \leq V_{in} \leq 8V$		0.2	0.3	%/V
ΔV_{out}	Load Regulation	$V_{in}=6.0V$ $1mA \leq I_{out} \leq 100mA$		20	40	mV
I_q	Quiescent Current	$V_{in}=6V$		3.0	5.0	μA
$\frac{\Delta V_{out}}{\Delta T \cdot V_{out}}$	Output Voltage Temperature Coefficient	$I_{out}=10mA$		50		ppm/ $^{\circ}C$

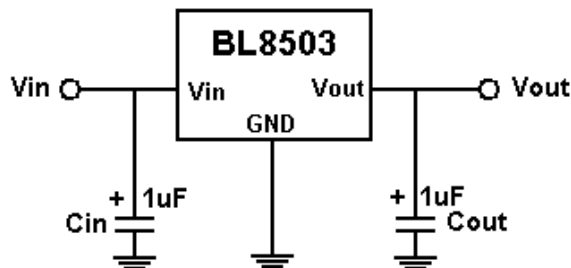
Typical Application Circuit:

Application hints:

- NOTE1 : Input capacitor ($C_{in}=1\mu F$) is recommended in all application circuit. Tantalum capacitor is recommended.
- NOTE2 : Output capacitor ($C_{out}=1\mu F$) is recommended in all application to assure the stability of circuit. Tantalum capacitor is recommended.

Explanation:

BL8503 is a series of low dropout voltage and low power consumption three pins regulator. Its application circuit is very simple, which only needs two outside capacitors. It is composed of these modules: high accuracy voltage reference, current limit circuit, error amplifier, output driver and power transistor.

Current Limit module can keep chip and power system away from danger when load current is more than 250mA.

BL8503 uses trimming technique to assure the accuracy of output value within $\pm 2\%$, at the same time, temperature compensated is elaborately considered in this chip, which makes BL8503's temperature coefficient within 50ppm/ $^{\circ}C$.

Typical Performance Characteristics:

1. Load regulation

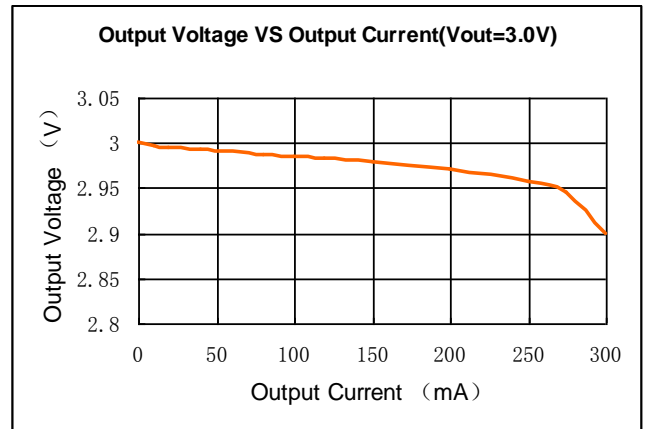
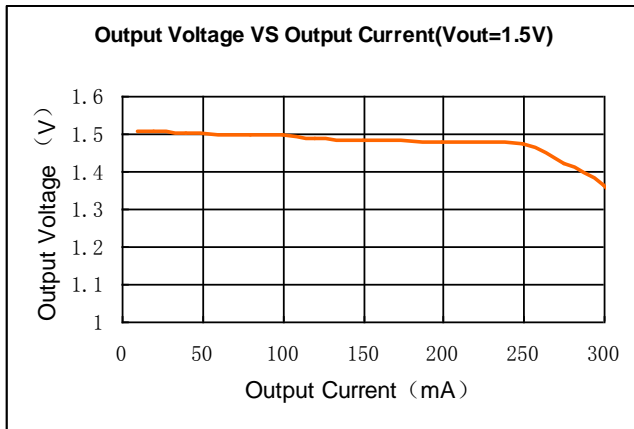

2. Line Regulation

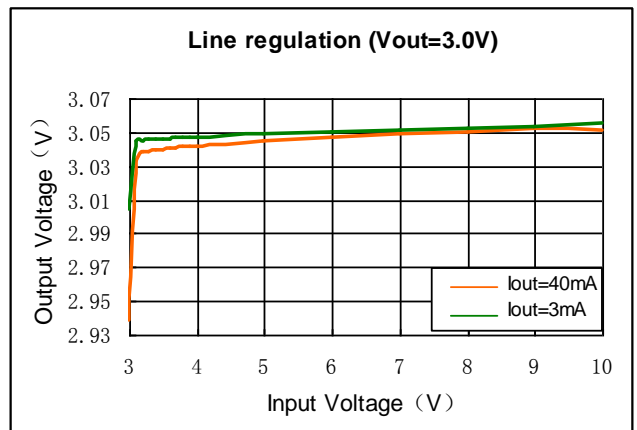
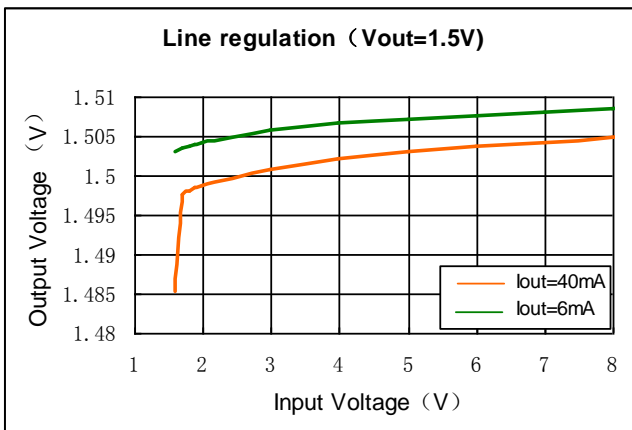

3. Dropout Voltage

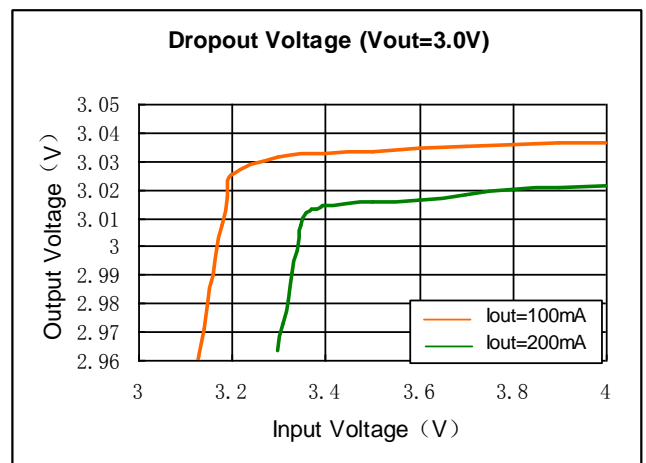
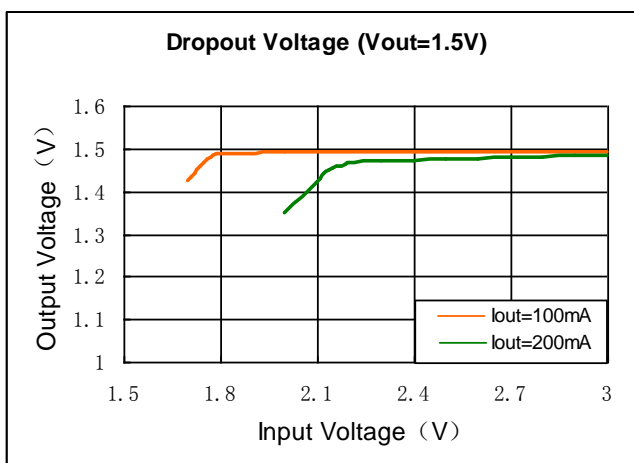

4. Input Voltage transient response
($V_{out}=1.5V, I_{out}=10mA$)

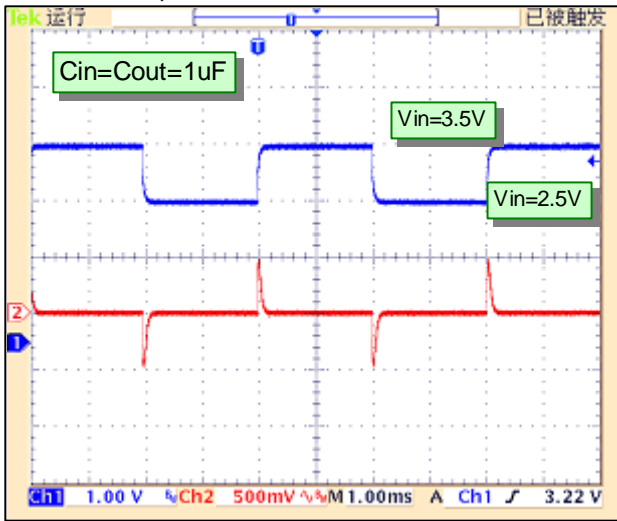

Input Voltage transient response
($V_{out}=1.5V, I_{out}=1mA$)

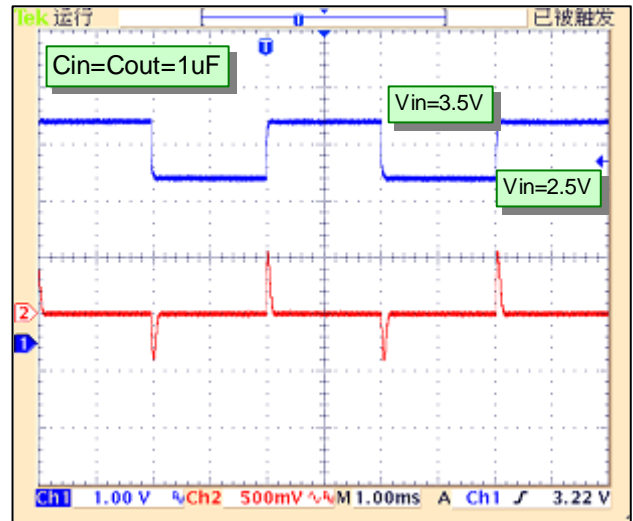

Input Voltage transient response
($V_{out}=3.0V, I_{out}=10mA$)

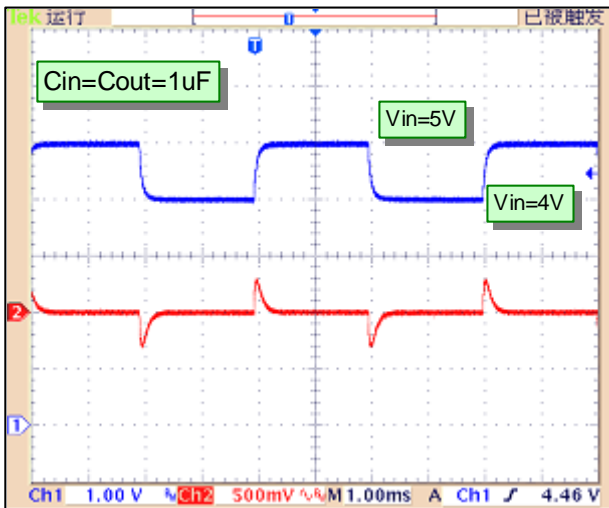

Input Voltage transient response
($V_{out}=3.0V, I_{out}=1mA$)

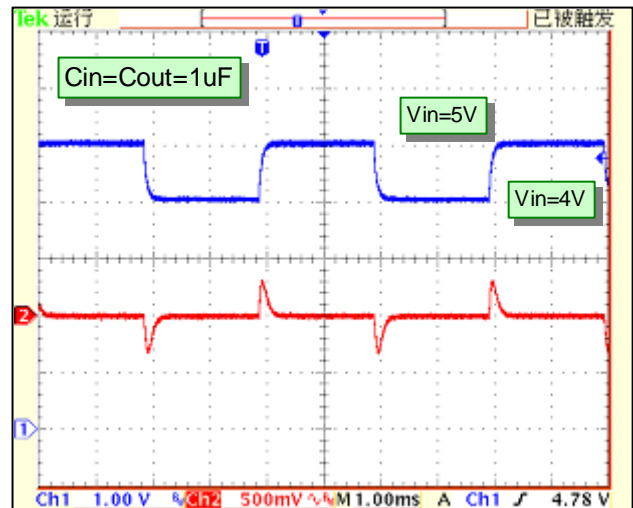

5. Load transient response ($V_{out}=1.5V$)

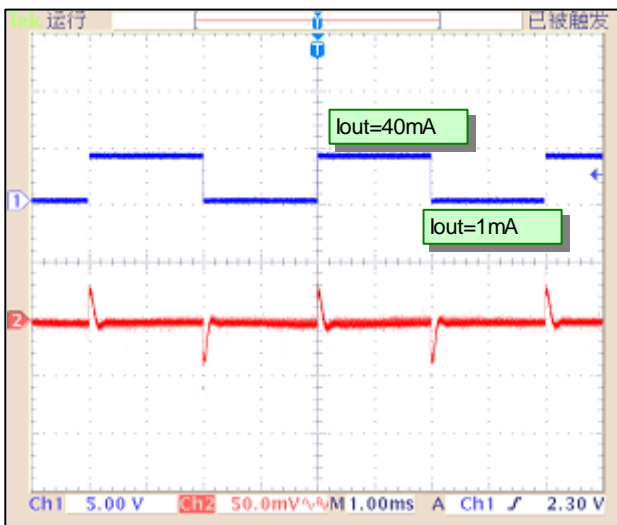

Load transient response ($V_{out}=3.0V$)

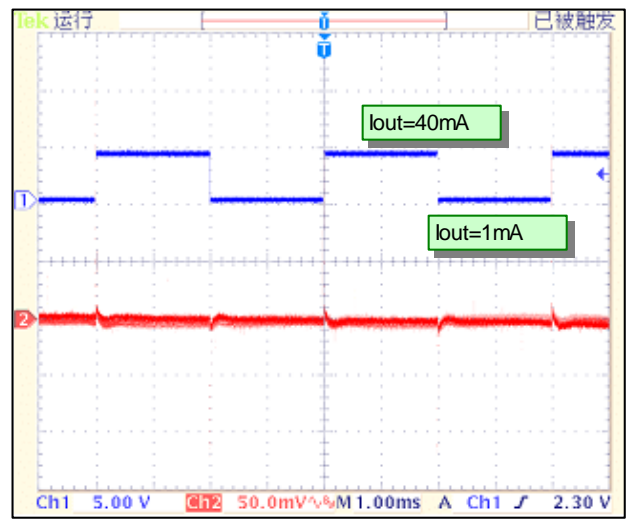

Taping Reel Dimension:

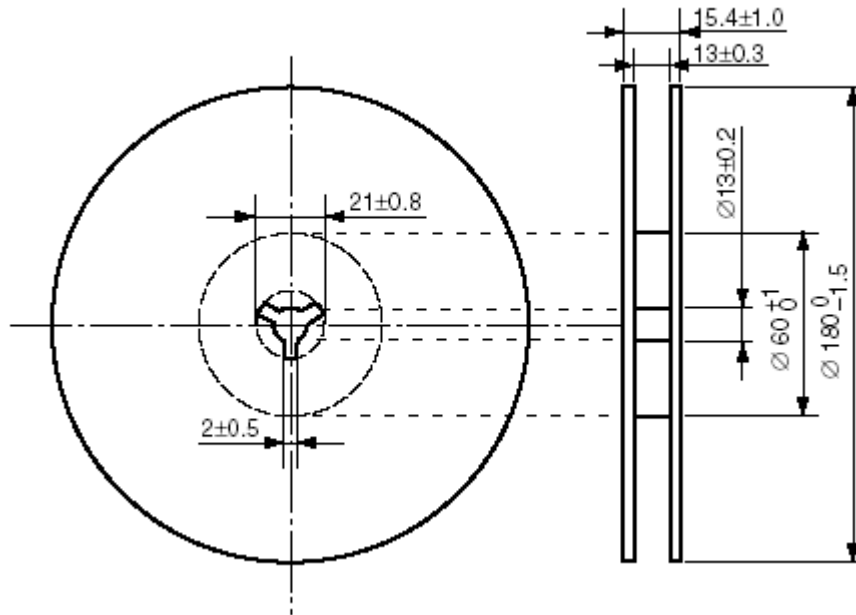

SOT-23-3:

Package	SOT-23-3	Devices per reel	3000	Unit	mm
---------	----------	------------------	------	------	----

Package dimension:

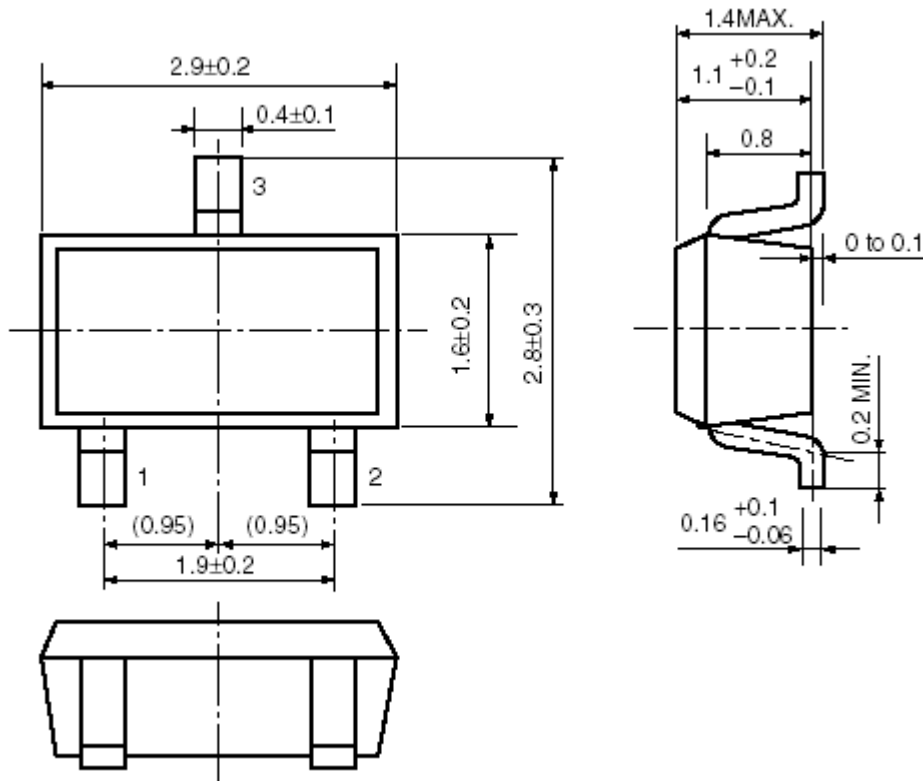

Taping Specification:

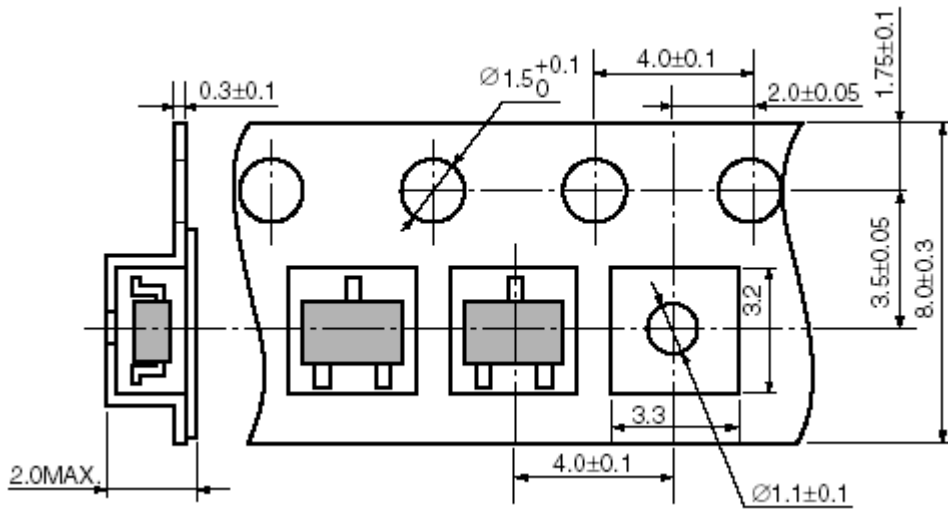

Taping reel dimension:

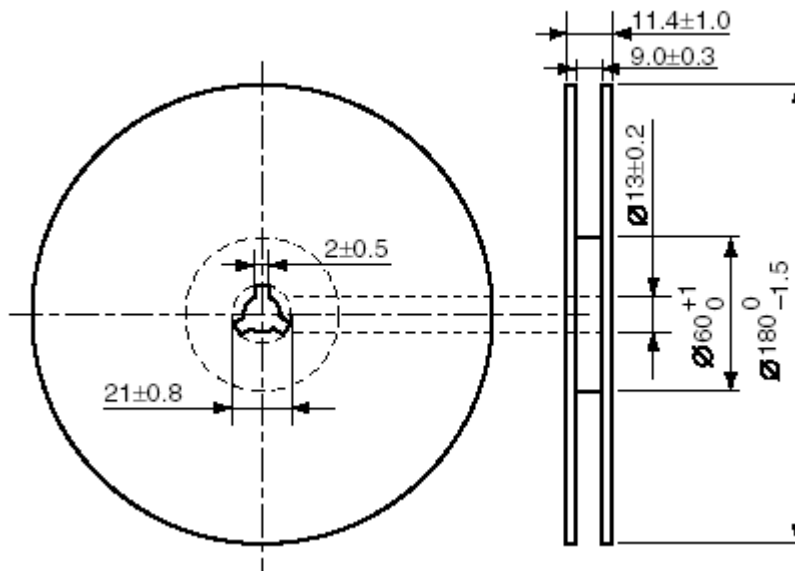

SOT-23-5:

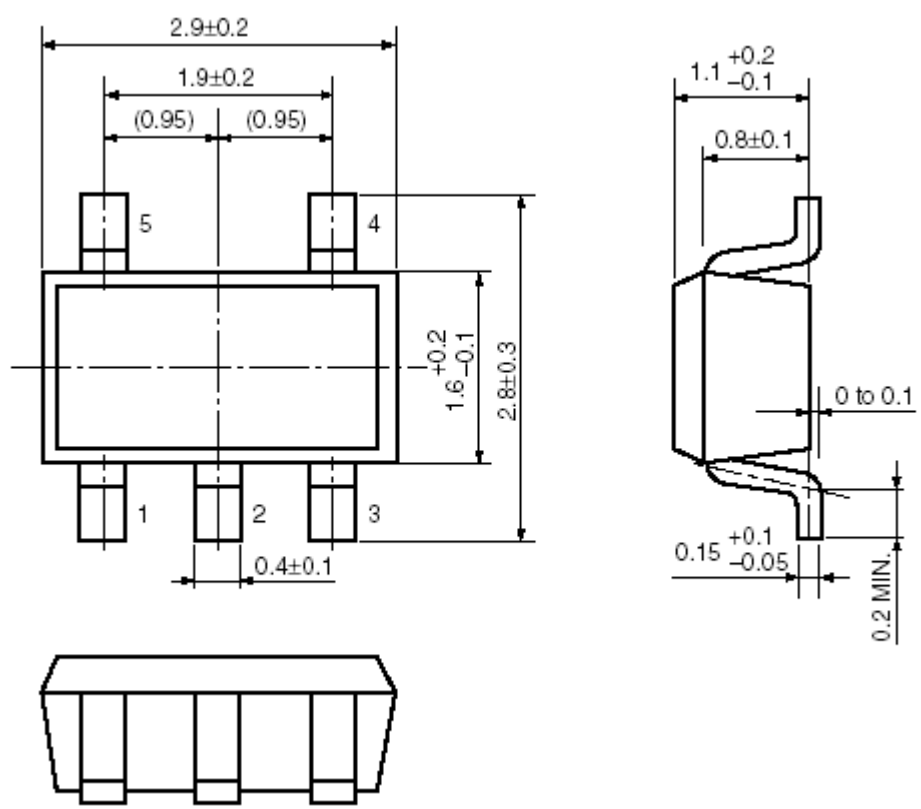
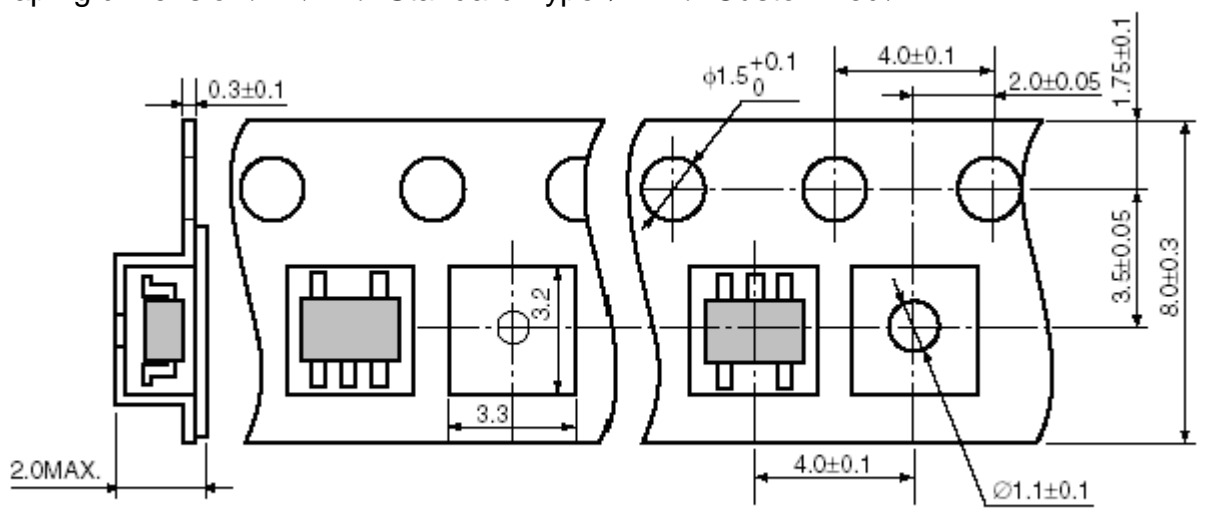
Package	SOT-23-5	Devices per reel	3000	Unit	mm
Package specification: 					
Taping dimension: (M1: Standard Type , M2: Customized) 					

Taping reel dimension:

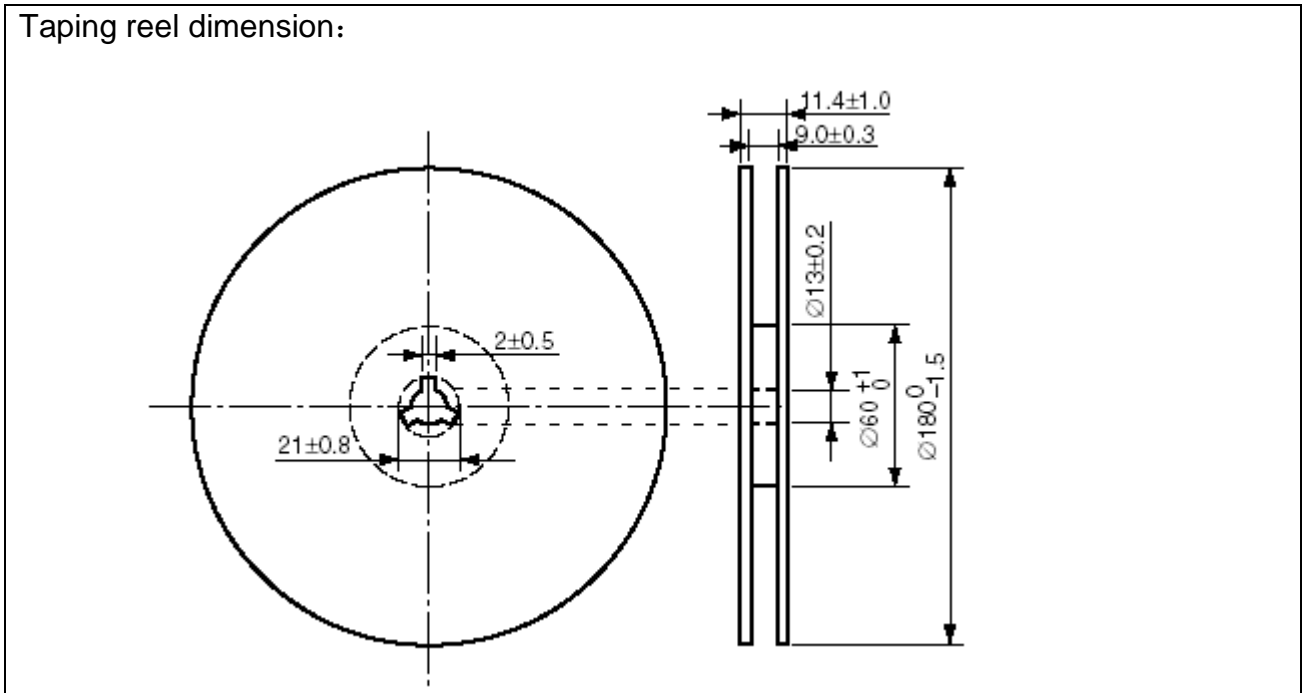

X-ON Electronics

Largest Supplier of Electrical and Electronic Components

Click to view similar products for [Linear Voltage Regulators](#) category:

Click to view products by [Belling](#) manufacturer:

Other Similar products are found below :

[LV5684PVD-XH](#) [MCDTSA6-2R](#) [L7815ACV-DG](#) [LV56801P-E](#) [UA7805CKC](#) [714954EB](#) [ZMR500QFTA](#) [BA033LBSG2-TR](#)
[NCV78M05ABDTRKG](#) [LV5680P-E](#) [L79M05T-E](#) [L78LR05D-MA-E](#) [NCV317MBTG](#) [NTE7227](#) [MP2018GZD-33-P](#) [MP2018GZD-5-P](#)
[LV5680NPVC-XH](#) [ZTS6538SE](#) [UA78L09CLP](#) [UA78L09CLPR](#) [CAT6221-PPTD-GT3](#) [MC78M09CDTRK](#) [NCV51190MNTAG](#)
[BL1118CS8TR1833](#) [BL8563CKETR18](#) [BL8077CKETR33](#) [BL9153-33CC3TR](#) [BL9161G-15BADRN](#) [BL9161G-28BADRN](#)
[BRCO7530MMC](#) [CJ7815B-TFN-ARG](#) [LM317C](#) [GM7333K](#) [GM7350K](#) [XC6206P332MR](#) [HT7533](#) [LM7912S/TR](#) [LT1764S/TR](#) [LM7805T](#)
[LM338T](#) [LM1117IMP-3.3/TR](#) [HT1117AM-3.3](#) [HT7550S](#) [AMS1117-3.3](#) [HT7150S](#) [78L12](#) [HT7550](#) [HT7533-1](#) [HXY6206I-2.5](#) [HT7133](#)