

## 400mA CMOS Low Dropout Voltage Low consumption Regulator

### Features :

- Low Power Consumption : 7uA ( Typ. )
- Maximum Output Current : 400mA
- Small Dropout Voltage :  
 250mV@100mA (Vout=2.0V)  
 470mV@200mA (Vout=2.0V)
- Input Voltage Range : 2.0V ~ 10V
- Output Voltage Range : 1.5V~6.0V  
 ( customized on command in 0.1V steps )
- Highly Accurate :  $\pm 2\%$  ( $\pm 1\%$  customized )
- Output Current Limit

### Applications :

- Battery Powered equipment
- Power Management of MP3、PDA、DSC、Mouse、PS2 Games
- Reference Voltage Source
- Regulation after Switching Power

### Outline :

BL8553 series is a group of positive voltage output, low power consumption, low dropout voltage, three terminal regulator. It can provide 200mA output current when input / output voltage differential drops to 470mV ( Vout=2.0V ) 。 The very low power consumption of BL8553 ( Iq=7uA ) can greatly improve natural life of batteries.

BL8553 can provide output value in the range of 1.5V~6.0V in 0.1V steps. It also can customized on command.

BL8553 includes high accuracy voltage reference, error amplifier, current limit circuit and output driver module.

BL8553 has well load transient response and good temperature characteristic, which can assure the stability of chip and power system. And it uses trimming technique to guarantee output voltage accuracy within  $\pm 2\%$ .

BL8553 is available in SOT-89-3、SOT-23-3、SOT-23-5 packages which is lead free , it also can available in these packages with lead.

### BL8553 Typical Application Circuit

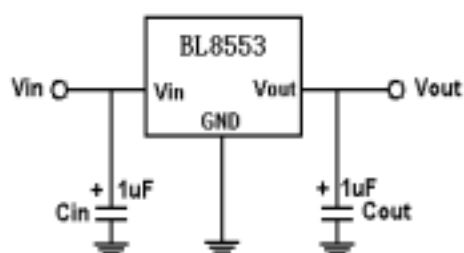

### Application hints :

NOTE1 : Input capacitor (Cin=1uF) is recommended in all application circuit. Tantalum capacitor is recommended.

NOTE2 : Output capacitor (Cout=1uF) is recommended in all application to assure the stability of circuit. Tantalum capacitor is recommended.

### BL8553 Typical Performance Characteristic :

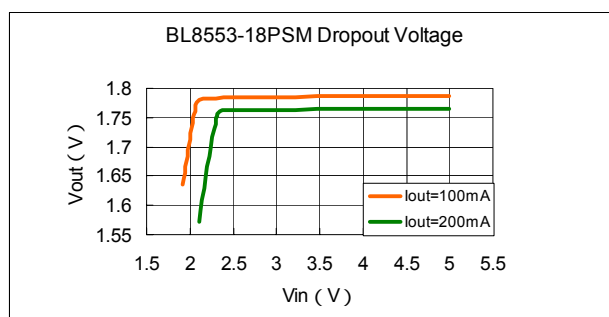

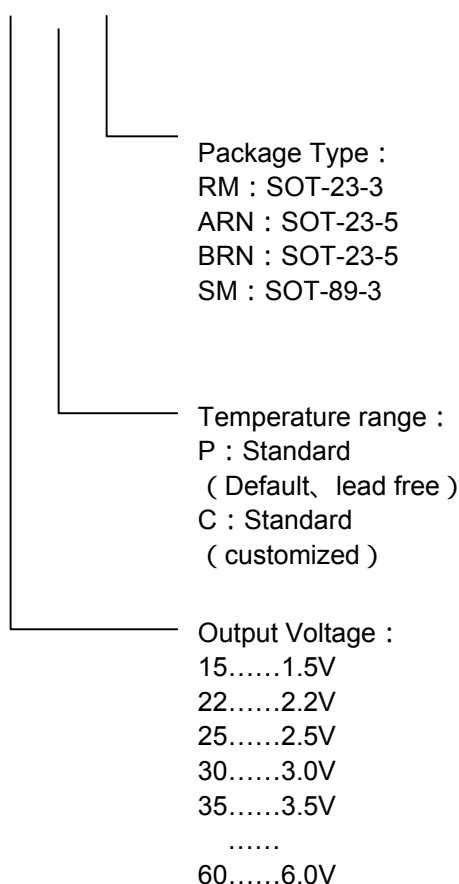
**Selection Guide :**
**BL8553-XX X X**

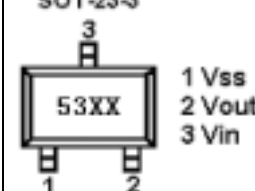
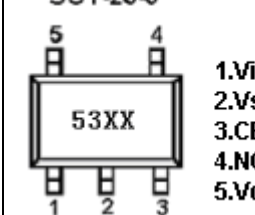
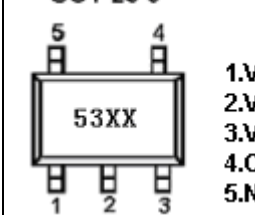
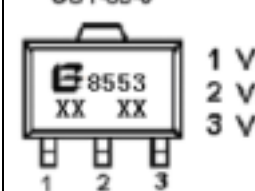
**Pin Assignment :**



Product Classification	Pin Configuration
BL8553- PRM	SOT-23-3 
BL8553- PARN	SOT-23-5 
BL8553- PBRN	SOT-23-5 
BL8553- PSM	SOT-89-3 

**Pin Description :**

PIN Number		PIN Name	Function
SOT-23-3	SOT-89-3		
1	1	<b>Vss</b>	Ground
3	2	<b>Vin</b>	Supply voltage input
2	3	<b>Vout</b>	Output Voltage
-	-	<b>NC</b>	No connect
-	-	<b>NC</b>	No connect

PIN Number		PIN Name	Function
SOT-23-5(A)	SOT-23-5(B)		
1	3	<b>Vin</b>	Supply voltage input
2	2	<b>Vss</b>	Ground
3	4	<b>CE</b>	Enable Pin
4	5	<b>NC</b>	No connect
5	1	<b>Vout</b>	Output Voltage

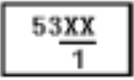
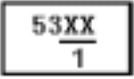
**Product Classification :**

Product Name	Output Voltage	Package Type	Package Marking
BL8553-15PRM	1.5V	SOT-23-3	 <b>1 Output Voltage</b>
BL8553-18PRM	1.8V	SOT-23-3	
BL8553-22PRM	2.2V	SOT-23-3	
BL8553-25PRM	2.5V	SOT-23-3	
BL8553-30PRM	3.0V	SOT-23-3	
-----	-----	SOT-23-3	
BL8553-60PRM	6.0V	SOT-23-3	 <b>1 Output Voltage</b>
BL8553-15PARN	1.5V	SOT-23-5	
BL8553-18PARN	1.8V	SOT-23-5	
BL8553-22PARN	2.2V	SOT-23-5	
BL8553-25PARN	2.5V	SOT-23-5	
BL8553-30PARN	3.0V	SOT-23-5	
-----	-----	SOT-23-5	 <b>1 Output Voltage</b> <b>2 Lot NO.</b>
BL8553-60PARN	6.0V	SOT-23-5	
BL8553-15PSM	1.5V	SOT-89-3	
BL8553-18PSM	1.8V	SOT-89-3	
BL8553-22PSM	2.2V	SOT-89-3	
BL8553-25PSM	2.5V	SOT-89-3	
BL8553-30PSM	3.0V	SOT-89-3	
-----	-----	SOT-89-3	
BL8553-60PSM	6.0V	SOT-89-3	

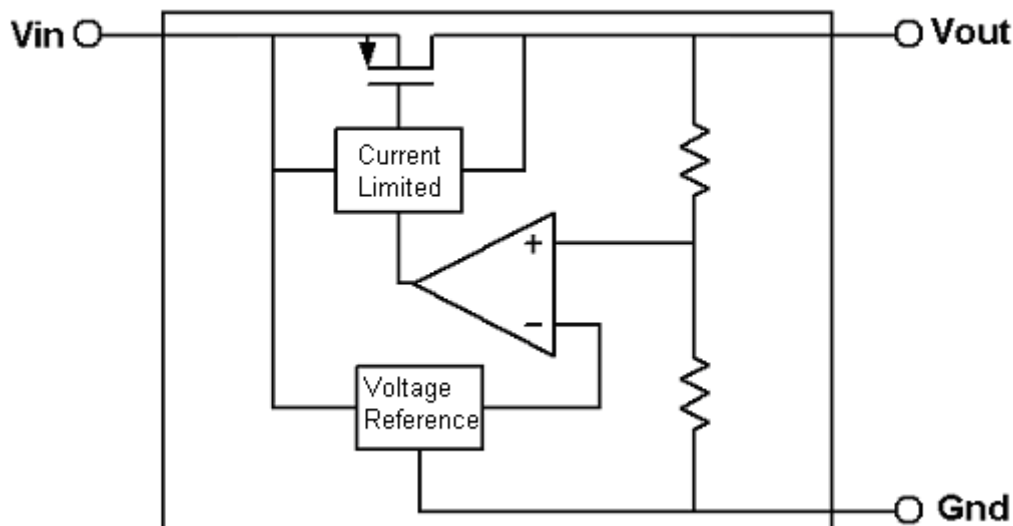
**Block Diagram :**

**Absolute Maximum Ratings :**

Max input voltage-----	10V
Junction Temperature (T <sub>J</sub> ) -----	125°C
Ambient Temperature(T <sub>A</sub> )-----	40°C ~ 85°C
Power Dissipation	
SOT-23-3 -----	0.15W
SOT-23-5 -----	0.25W
SOT-89-3 -----	0.5W
Storage Temperature(T <sub>s</sub> ) -----	-45°C ~ 150°C
Lead Temperature and Time -----	260°C, 10S

**Recommended Work Conditions :**

Item	Min	Recommended	Max	unit
Input Voltage Range			8	V
Ambient Temperature	-40		+125	°C

**Electrical Characteristics :**

 ( Test Conditions :  $C_{in}=1\mu F, C_{out}=1\mu F, T_A=25^\circ C$ , unless otherwise specified. )

**BL8553-1.8V**

Symbol	Parameter	Conditions	Min	Typ	Max	Units
$V_{in}$	Input Voltage				8	V
$V_{out}$	Output Voltage		1.764	1.8	1.836	V
$I_{out(Max.)}$	Maximum Output Current	$V_{in}=V_{out}+1.0V, V_{out}>1.8V*0.95$	400			mA
Dropout Voltage	Input-Output Voltage Differential	$I_{out}=100mA$		300	400	mV
		$I_{out}=200mA$		600	700	
$\frac{\Delta V_{out}}{\Delta V_{in} \cdot V_{out}}$	Line Regulation	$I_{out}=40mA$ $2V \leq V_{in} \leq 8V$		0.2	0.3	%/V
$\Delta V_{out}$	Load Regulation	$V_{in}=2.8V$ $1mA \leq I_{out} \leq 100mA$		20	40	mV
$I_q$	Quiescent Current	$V_{in}=V_{out}+1V$		7	10	$\mu A$
Noise	Output Noise	$f=10Hz$ to $100kHz, C_{out}=1\mu F$		40		$\mu V_{rms}$
PSRR	Ripple Rejection	$F=100Hz, I_{out}=40mA, C_{out}=1\mu F$		60		dB
$\frac{\Delta V_{out}}{\Delta T \cdot V_{out}}$	Output Voltage Temperature Coefficient			50		ppm/°C

**BL8553-2.0V**

Symbol	Parameter	Conditions	Min	Typ	Max	Units
$V_{in}$	Input Voltage				8	V
$V_{out}$	Output Voltage	$V_{in}=V_{out}+1.0V, I_{out}=40mA$	1.96	2.0	2.04	V
$I_{out(Max.)}$	Maximum Output Current	$V_{in}=V_{out}+1.0V, V_{out}>2.0V*0.95$	400			mA
Dropout Voltage	Input-Output Voltage Differential	$I_{out}=100mA$		250	400	mV
		$I_{out}=200mA$		470	600	
$\frac{\Delta V_{out}}{\Delta V_{in} \cdot V_{out}}$	Line Regulation	$I_{out}=40mA$ $2.2V \leq V_{in} \leq 8V$		0.2	0.3	%/V
$\Delta V_{out}$	Load Regulation	$V_{in}=3.0V$ $1mA \leq I_{out} \leq 100mA$		20	40	mV
$I_q$	Quiescent Current	$V_{in}=V_{out}+1V$		7	10	$\mu A$
Noise	Output Noise	$f=10Hz$ to $100kHz, C_{out}=1\mu F$		40		$\mu V_{rms}$
PSRR	Ripple Rejection	$F=100Hz, I_{out}=40mA, C_{out}=1\mu F$		60		dB
$\frac{\Delta V_{out}}{\Delta T \cdot V_{out}}$	Output Voltage Temperature Coefficient			50		ppm/°C

## BL8553-3.0V

Symbol	Parameter	Conditions	Min	Typ	Max	Units
Vin	Input Voltage				8	V
Vout	Output Voltage	Vin=Vout+1.0V, Iout=40mA	2.94	3.0	3.06	V
Iout(Max.)	Maximum Output Current	Vin=Vout+1.0V, Vout>3.0V*0.95	400			mA
Dropout Voltage	Input-Output Voltage Differential	Iout=100mA		200	400	mV
		Iout=200mA		400	600	
$\frac{\Delta V_{out}}{\Delta V_{in} \cdot V_{out}}$	Line Regulation	Iout=40mA 3.2V≤Vin≤8V		0.2	0.3	%/V
$\Delta V_{out}$	Load Regulation	Vin=4.0V 1mA≤Iout≤100mA		20	40	mV
Iq	Quiescent Current	Vin=Vout+1V		7	10	uA
Noise	Output Noise	f=10Hz to 100kHz, Cout=1uF		40		uVrms
PSRR	Ripple Rejection	F=100Hz, Iout=40mA, Cout=1uF		60		dB
$\frac{\Delta V_{out}}{\Delta T \cdot V_{out}}$	Output Voltage Temperature Coefficient			50		ppm/°C

## BL8553-3.3V

Symbol	Parameter	Conditions	Min	Typ	Max	Units
Vin	Input Voltage				8	V
Vout	Output Voltage	Vin=Vout+1.0V, Iout=40mA	3.234	3.3	3.366	V
Iout(Max.)	Maximum Output Current	Vin=Vout+1.0V, Vout>3.3V*0.95	400			mA
Dropout Voltage	Input-Output Voltage Differential	Iout=100mA		200	400	mV
		Iout=200mA		400	600	
$\frac{\Delta V_{out}}{\Delta V_{in} \cdot V_{out}}$	Line Regulation	Iout=40mA 3.5V≤Vin≤8V		0.2	0.3	%/V
$\Delta V_{out}$	Load Regulation	Vin=4.3V 1mA≤Iout≤100mA		20	40	mV
Iq	Quiescent Current	Vin=Vout+1V		7	10	uA
Noise	Output Noise	f=10Hz to 100kHz, Cout=1uF		40		uVrms
PSRR	Ripple Rejection	F=100Hz, Iout=40mA, Cout=1uF		60		dB
$\frac{\Delta V_{out}}{\Delta T \cdot V_{out}}$	Output Voltage Temperature Coefficient			50		ppm/°C

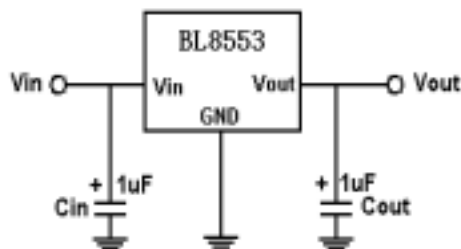
**Typical Application Circuit :**

**Application hints :**

NOTE1 : Input capacitor ( $C_{in}=1\mu F$ ) is recommended in all application circuit. Tantalum capacitor is recommended.

NOTE2 : Output capacitor ( $C_{out}=1\mu F$ ) is recommended in all application to assure the stability of circuit. Tantalum capacitor is recommended.

**Explanation :**

BL8553 is a series of low dropout voltage and low power consumption three pins regulator. Its application circuit is very simple, which only needs two outside capacitors. It is composed of these modules: high accuracy voltage reference, current limit circuit, error amplifier, output driver and power transistor.

Current Limit module can keep chip and power system away from danger when load current is more than 400mA.

BL8553 uses trimming technique to assure the accuracy of output value within  $\pm 2\%$ , at the same time, temperature compensated is elaborately considered in this chip, which makes BL8553's temperature coefficient within 50ppm/°C.

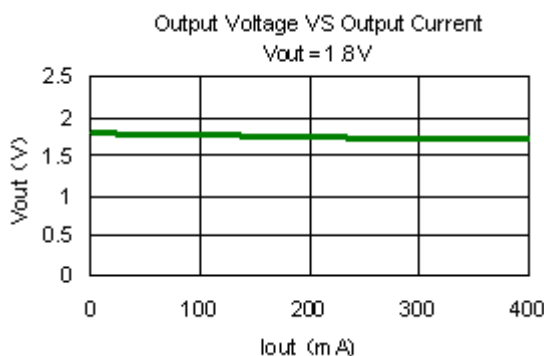
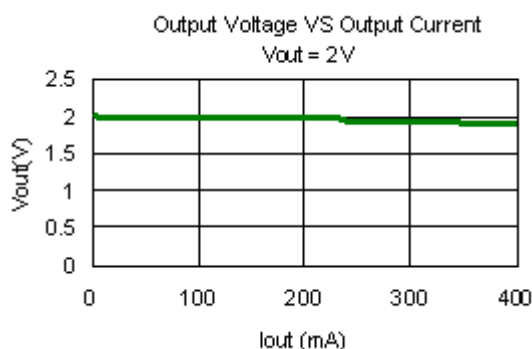
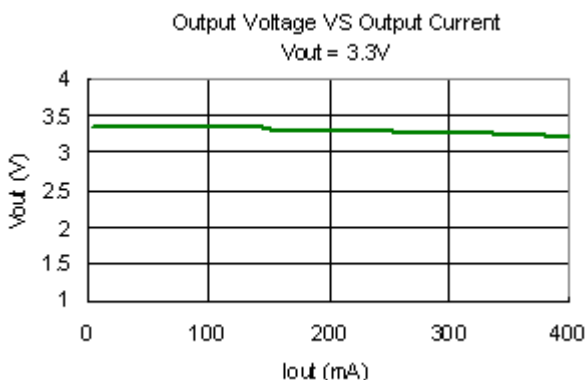
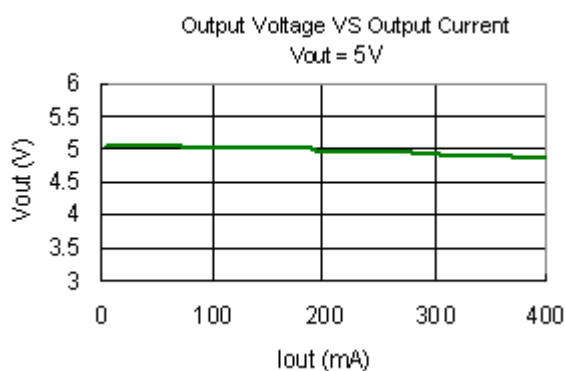
**Typical Performance Characteristics :**
**1. Load regulation**
**Vout=1.8V Load regulation ( Vin=2.8V )**

**Vout=2V Load regulation ( Vin=3V )**

**Vout=3.3V Load regulation ( Vin=4.3V )**

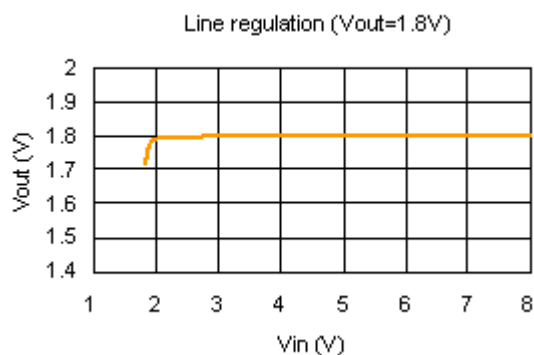
**Vout=5V Load regulation ( Vin=6V )**

**2. Line Regulation :**

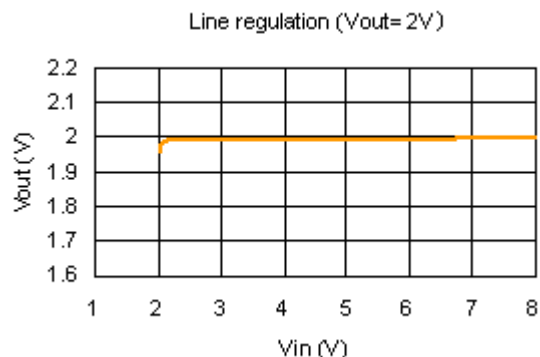
Vout=1.8V Line regulation ( Iout=40mA )



Vout=2.0V Line regulation ( Iout=40mA )



Vout=3.3V Line regulation ( Iout=40mA )

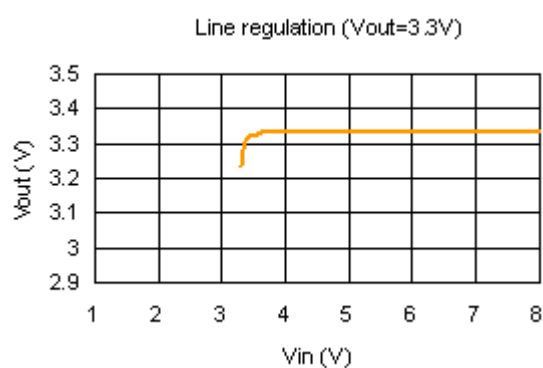

Vout=5.0V Line regulation ( Iout=40mA )

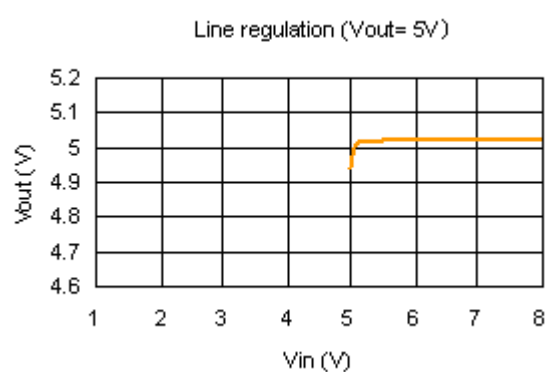

**3.Input Voltage transient response:**

Vout=1.8V ( Iout=10mA )

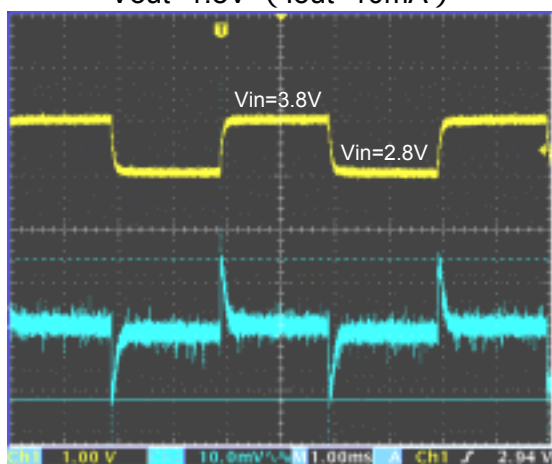

Vout=2.0V ( Iout=10mA )

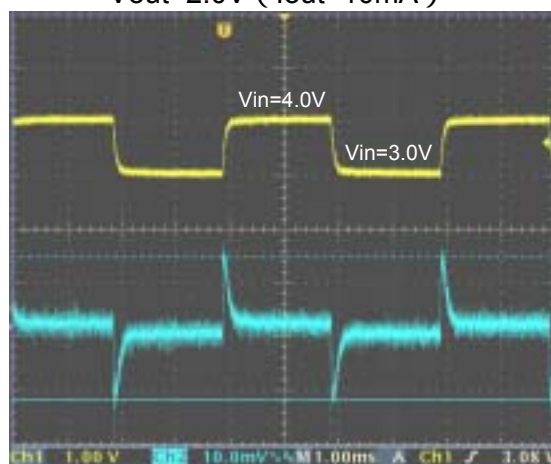

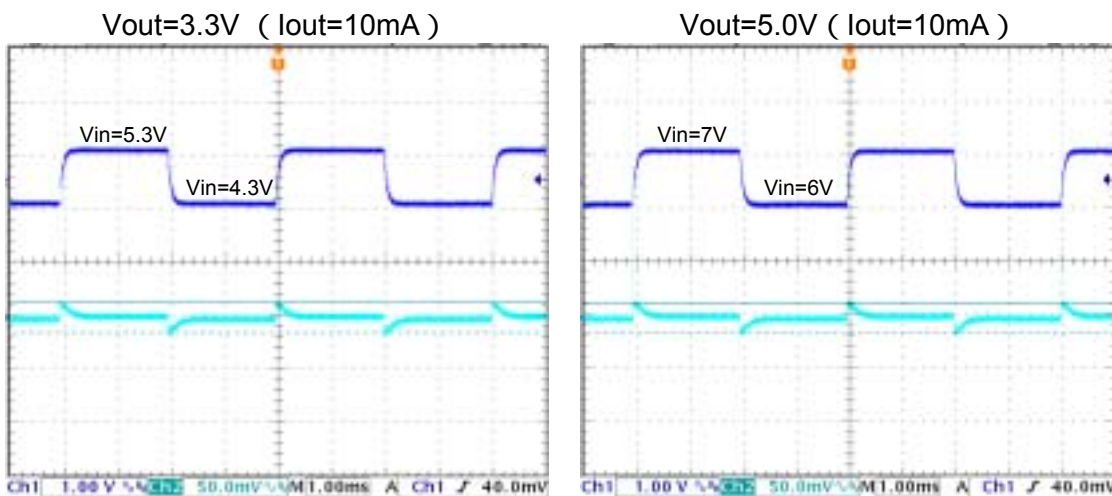

**4. Load transient response:**

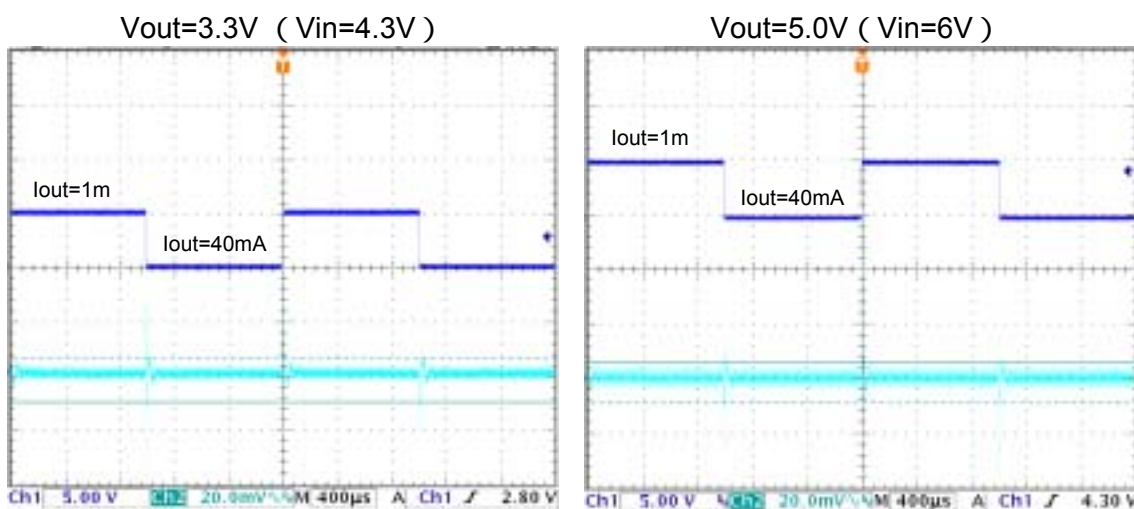

**5. Ripple rejection:**

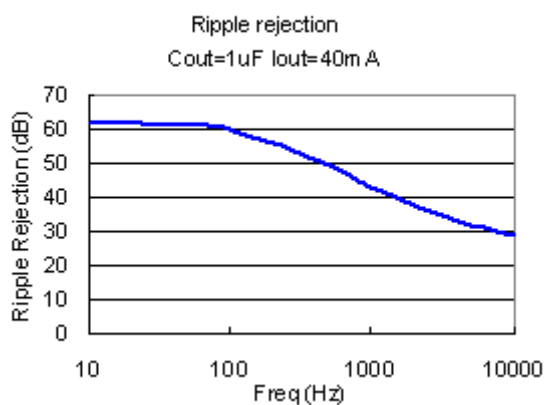



**Package Outline :**

Package	SOT-89-3	Devices per reel	1000	Unit	mm
---------	----------	------------------	------	------	----

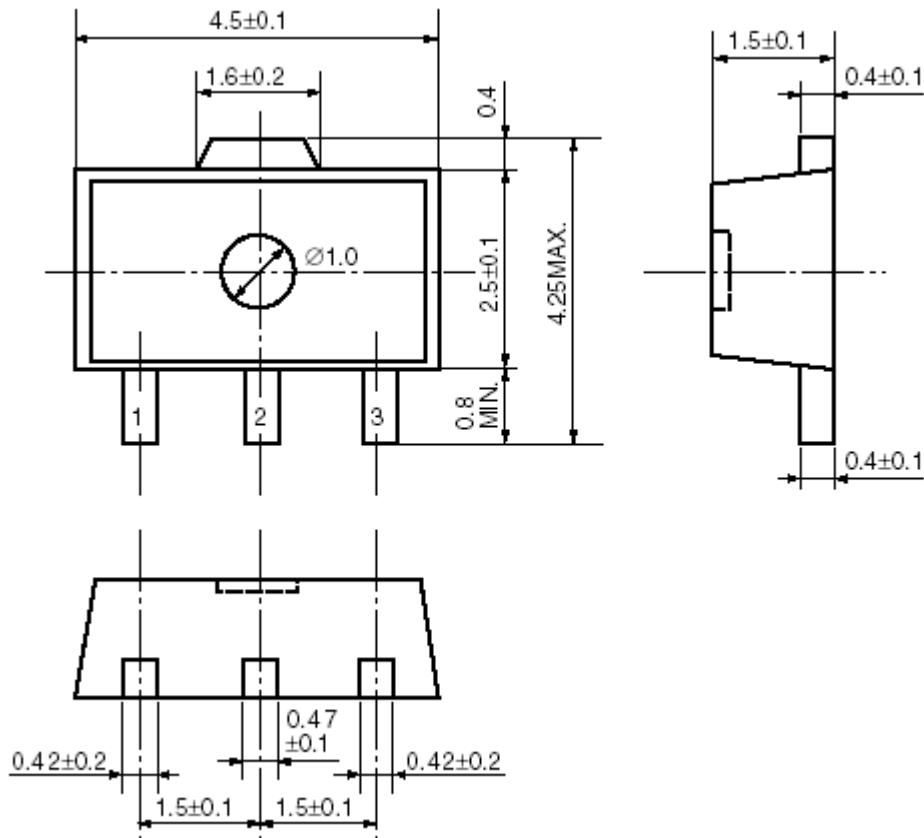
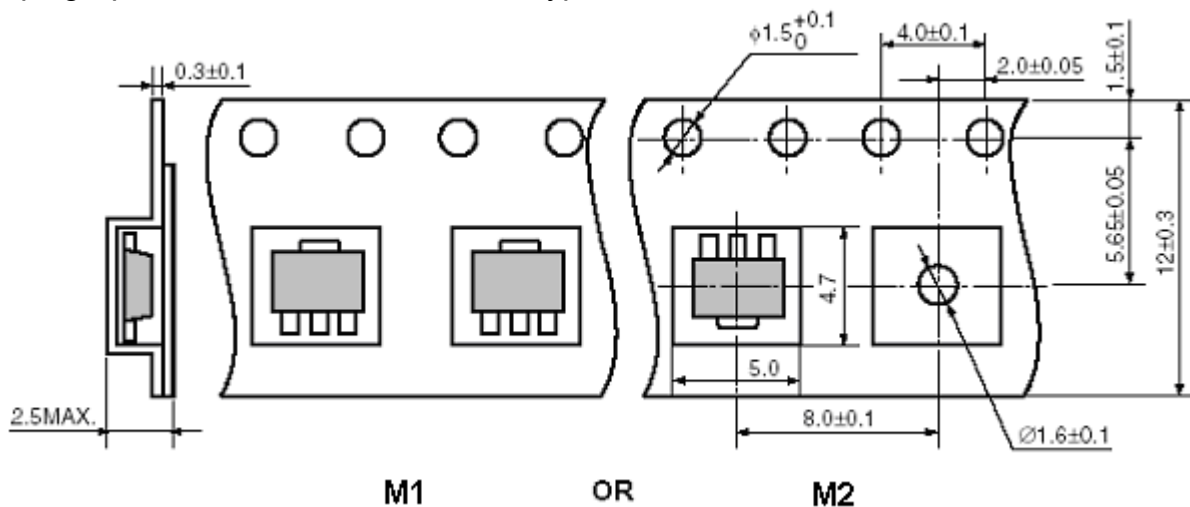
**Package Dimension:**

**Taping Specification: ( M1 : Standard Type , M2 : Customized )**

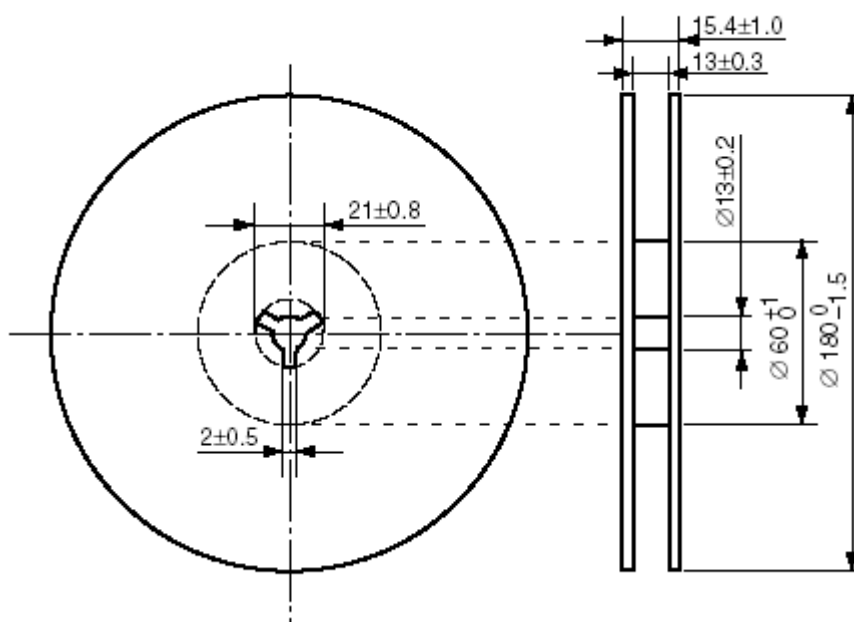
Taping Reel Dimension :



**SOT-23-3:**

Package	SOT-23-3	Devices per reel	3000	Unit	mm
---------	----------	------------------	------	------	----

Package dimension :

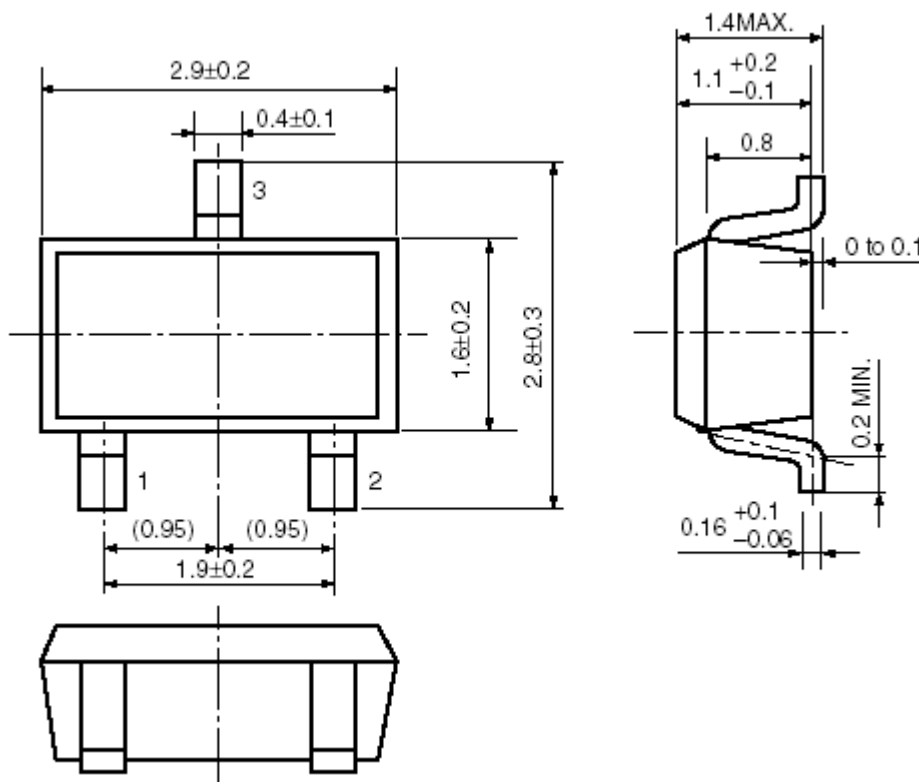

Taping Specification :

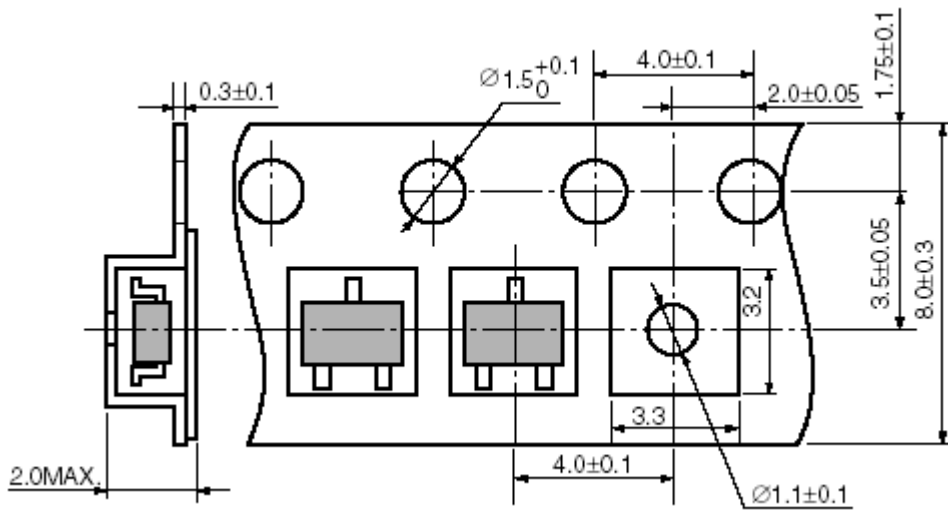

Taping reel dimension :

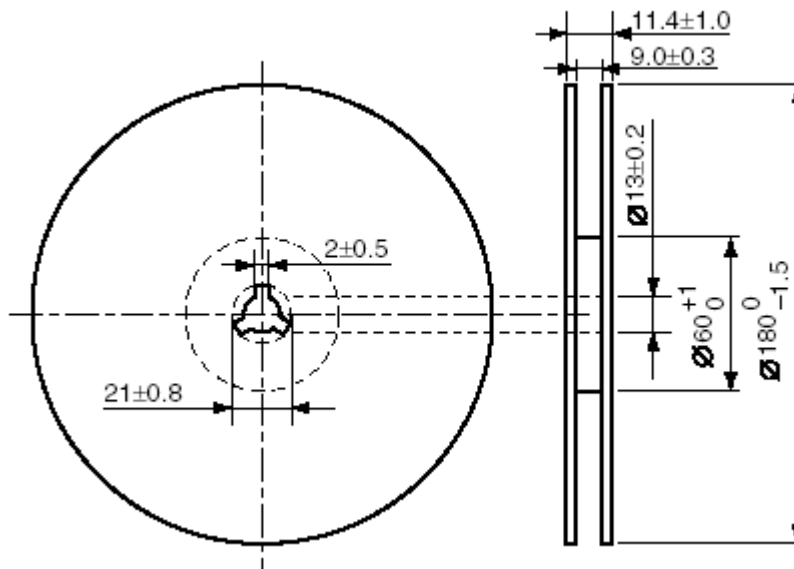

**SOT-23-5:**

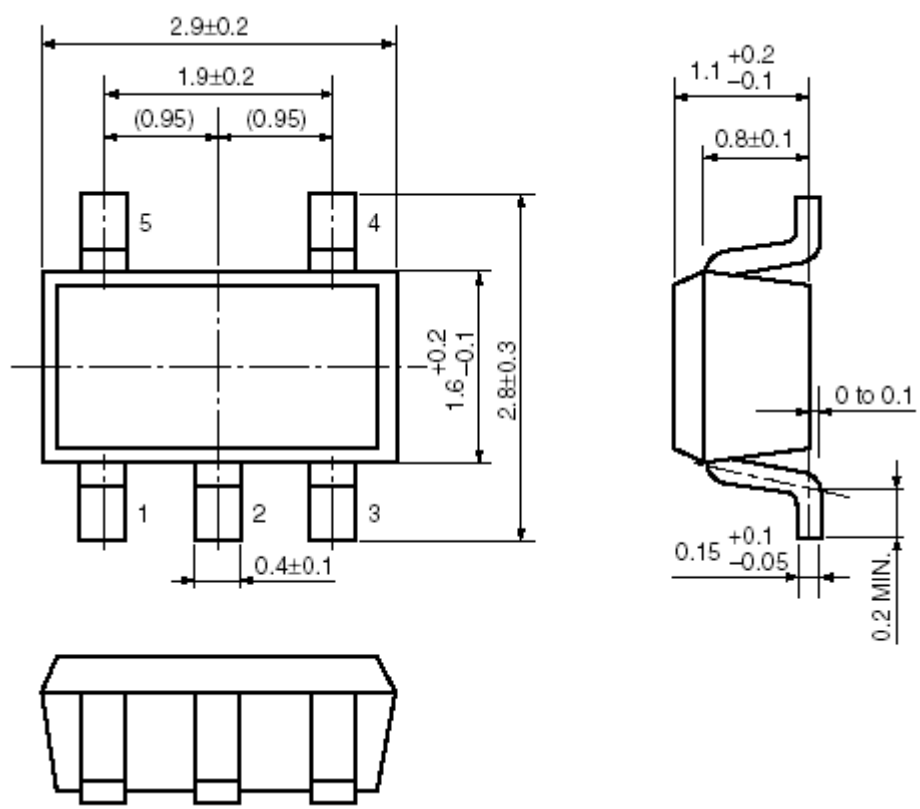
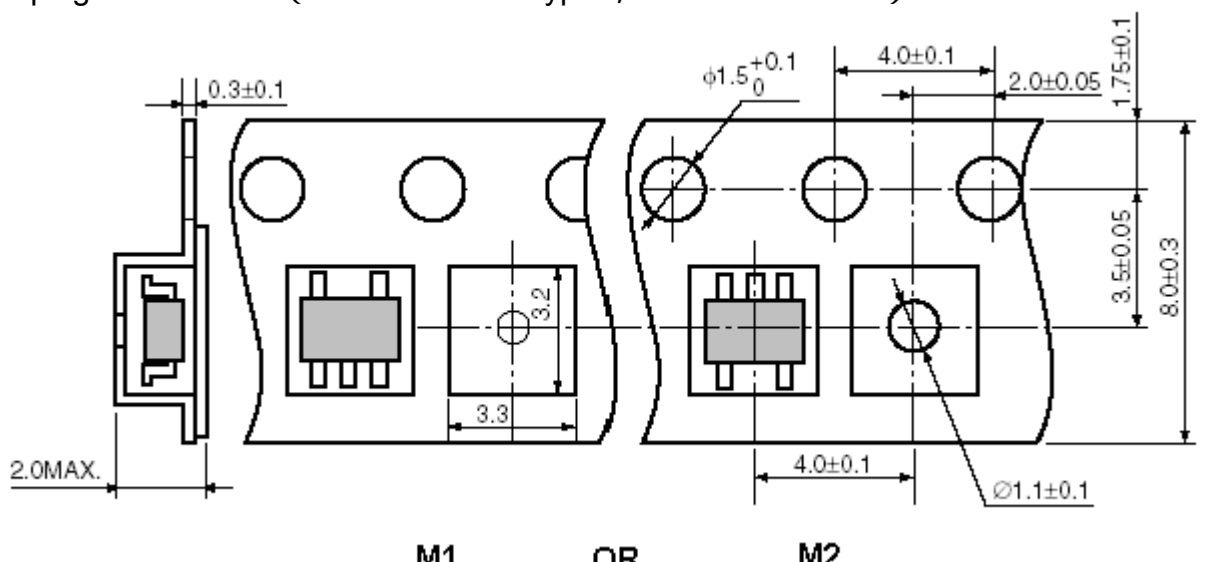
Package	SOT-23-5	Devices per reel	3000	Unit	mm
Package specification :  <p>                         The package specification drawings show a top view with dimensions: total width <math>2.9 \pm 0.2</math> mm, distance between pins 1 and 5 <math>1.9 \pm 0.2</math> mm, and individual pin spacing of <math>0.95</math> mm. Pin 1 is <math>0.4 \pm 0.1</math> mm from the left edge, and pin 5 is <math>0.4 \pm 0.1</math> mm from the right edge. The body height is <math>1.6^{+0.2}_{-0.1}</math> mm, and the total height including leads is <math>2.8 \pm 0.3</math> mm. A side view shows a lead height of <math>1.1^{+0.2}_{-0.1}</math> mm, a lead width of <math>0.8 \pm 0.1</math> mm, and a lead thickness of <math>0.15^{+0.1}_{-0.05}</math> mm. A fillet radius is specified as <math>0.2</math> MIN. A bottom view shows the package footprint with a width of <math>3.3</math> mm and a length of <math>3.2</math> mm.                     </p>					
Taping dimension : ( M1 : Standard Type , M2 : Customized )  <p>                         The taping dimension drawings show two carrier types, M1 and M2. M1 has a carrier width of <math>2.0</math> MAX. mm and a lead length of <math>0.3 \pm 0.1</math> mm. M2 has a carrier width of <math>4.0 \pm 0.1</math> mm and a lead length of <math>1.75 \pm 0.1</math> mm. The carrier height is <math>8.0 \pm 0.3</math> mm. The carrier has three circular holes with a diameter of <math>\phi 1.5^{+0.1}_0</math> mm. The distance between the center of the first and last hole is <math>4.0 \pm 0.1</math> mm. The distance between the center of the first and second hole is <math>2.0 \pm 0.05</math> mm. The carrier has a width of <math>3.5 \pm 0.05</math> mm. The carrier has a length of <math>3.3</math> mm. The carrier has a diameter of <math>\phi 1.1 \pm 0.1</math> mm.                     </p>					

Taping reel dimension :

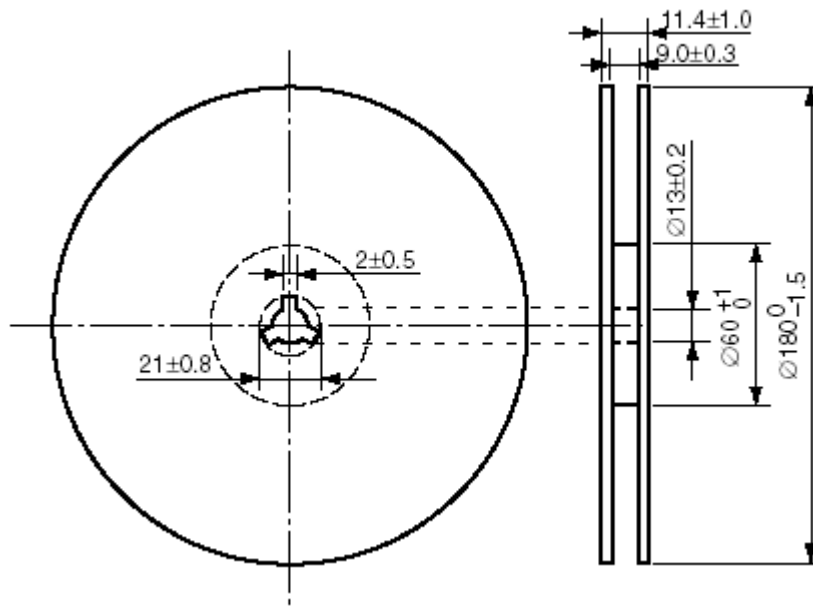

## X-ON Electronics

Largest Supplier of Electrical and Electronic Components

*Click to view similar products for [Linear Voltage Regulators](#) category:*

*Click to view products by [Belling](#) manufacturer:*

Other Similar products are found below :

[LV5684PVD-XH](#) [MCDTSA6-2R](#) [L7815ACV-DG](#) [LV56801P-E](#) [UA7805CKC](#) [714954EB](#) [ZMR500QFTA](#) [BA033LBSG2-TR](#)

[NCV78M05ABDTRKG](#) [LV5680P-E](#) [L79M05T-E](#) [L78LR05D-MA-E](#) [NCV317MBTG](#) [NTE7227](#) [MP2018GZD-33-P](#) [MP2018GZD-5-P](#)

[LV5680NPVC-XH](#) [ZTS6538SE](#) [UA78L09CLP](#) [UA78L09CLPR](#) [CAT6221-PPTD-GT3](#) [MC78M09CDTRK](#) [NCV51190MNTAG](#)

[BL1118CS8TR1833](#) [BL8563CKETR18](#) [BL8077CKETR33](#) [BL9153-33CC3TR](#) [BL9161G-15BADRN](#) [BL9161G-28BADRN](#)

[BRCO7530MMC](#) [CJ7815B-TFN-ARG](#) [LM317C](#) [GM7333K](#) [GM7350K](#) [XC6206P332MR](#) [HT7533](#) [LM7912S/TR](#) [LT1764S/TR](#) [LM7805T](#)

[LM338T](#) [LM1117IMP-3.3/TR](#) [HT1117AM-3.3](#) [HT7550S](#) [AMS1117-3.3](#) [HT7150S](#) [78L12](#) [HT7550](#) [HT7533-1](#) [HXY6206I-2.5](#) [HT7133](#)