

500mA High PSRR, Linear Regulator, w. Output Discharge

DESCRIPTION

BL8568G series is a group of positive voltage output, low power consumption, low dropout voltage regulator.

BL8568G can provide output value in the range of 0.9V~4.5V every 0.1V step. It also can be customized on command. BL8568G can also work under a wide input voltage ranging from 2.0V to 6V.

BL8568G includes high accuracy voltage reference, error amplifier, current limit circuit and output driver module.

BL8568G has excellent load and line transient response and good temperature characteristics, which can assure the stability of chip and power system. And it uses trimming technique to guarantee output voltage accuracy within $\pm 2\%$.

BL8568G is available in SOT-23-3, SOT-23-5, SC-70-5, DFN1x1-4 and DFN1.2x1.6-4 packages which is lead free.

TYPICAL APPLICATION

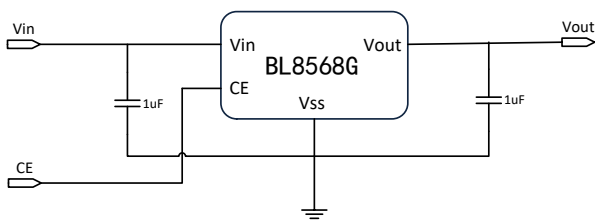

NOTE: Input capacitor ($C_{in}=1\mu F$) and Output capacitor ($C_{out}=1\mu F$) are recommended in all application circuit.

FEATURES

- Output voltage range: 0.9V~4.5V (customized on command every 0.1V step)
- Low power consumption: 80uA (Typ.)
- Shutdown mode: 0.1uA
- Low dropout voltage: 65mV@100mA @ $V_{OUT}=3.3V$ (Typ.)
- High ripple rejection: 70dB@1KHz (Typ.)
- Low temperature coefficient: $\pm 100\text{ppm}/^\circ\text{C}$
- Excellent line regulation: 0.05%/V
- Build-in chip enable and discharge circuit
- Highly accurate: $\pm 2\%$
- Output current limit

APPLICATIONS

- Power source for cellular phones and various kind of PCSs
- Battery Powered equipment
- Power Management of MP3, PDA, DSC, Mouse, PS2 Games
- Voltage Reference
- Regulation after Switching Power

ELECTRICAL CHARACTERISTICS

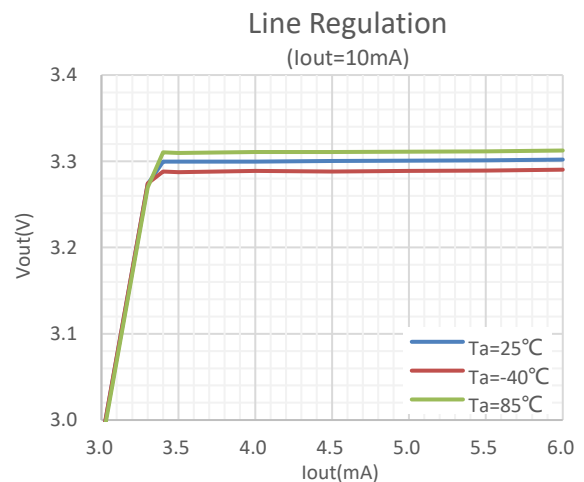

ORDERING INFORMATION

BL8568G 1 2 3 4

Code	Description
1	Temperature&RoHS: C:-40~85°C ,Pb Free RoHS Std.
2	Package type: A5: SC70-5 B3: SOT23-3 B5A: SOT23-5 KE: DFN1x1-4 KF: DFN1.2x1.6-4
3	Packing type: TR: Tape&Reel (Standard)
4	Output voltage: e.g. 15=1.5V 18=1.8V 45=4.5V

MARKING DESCRIPTON

H: Product Code

X: Output Voltage Code (for SC70-5, SOT23-3, SOT23-5)



Vout	Code	Vout	Code	Vout	Code
1.0V	0	2.3V	<u>3</u>	3.6V	<u>6</u>
1.1V	1	2.4V	<u>4</u>	3.7V	<u>7</u>
1.2V	2	2.5V	<u>5</u>	3.8V	<u>8</u>
1.3V	3	2.6V	<u>6</u>	3.9V	<u>9</u>
1.4V	4	2.7V	<u>7</u>	4.0V	<u>0</u>
1.5V	5	2.8V	<u>8</u>	4.1V	<u>1</u>
1.6V	6	2.9V	<u>9</u>	4.2V	<u>2</u>
1.7V	7	3.0V	<u>0</u>	4.3V	<u>3</u>
1.8V	8	3.1V	<u>1</u>	4.4V	<u>4</u>
1.9V	9	3.2V	<u>2</u>	4.5V	<u>5</u>
2.0V	<u>0</u>	3.3V	<u>3</u>		
2.1V	<u>1</u>	3.4V	<u>4</u>		
2.2V	<u>2</u>	3.5V	<u>5</u>		

XX: Output Voltage (for DFN1X1-4 and DFN1.2x1.6-4)."18"stands for 1.8V,"28" stands for 2.8V,and "28" stands for 2.85V.

Z: The Year of manufacturing,"1" stands for year 2011,"2" stands for year 2012, and "8" stands for year 2018.

Z: The week of manufacturing. "A" stands for week 1,"Z" stands for week 26," A " stands for week 27," Z " stands for week 52.

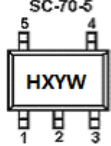
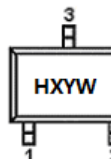
PIN CONFIGURATION

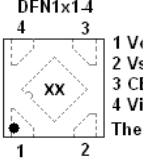
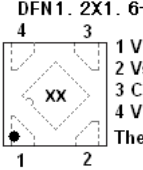
Product Classification	BL8568GCA5TR□□
H: Product Code	
X: Output Voltage	
ZZ: Date Code	
Product Classification	BL8568GCB3TR□□
H: Product Code	
X: Output Voltage	
ZZ: Date Code	
Product Classification	BL8568GCB5ATR□□
H: Product Code	
X: Output Voltage	
ZZ: Date Code	
Product Classification	BL8568GCKETR□□
XX: Output Voltage	
Product Classification	BL8568GCKFTR□□
XX: Output Voltage	
Vin	Supply Voltage Input
Vout	Output Voltage
CE	Chip Enable
NC	No Connection

ABSOLUTE MAXIMUM RATING

Parameter		Value
Max Input Voltage		8V
Operating Junction Temperature(Tj)		125°C
Output Current		500mA
Ambient Temperature(Ta)		-40°C –85°C
Power Dissipation	SC70-5	250mW
	SOT-23-3	400mW
	SOT-23-5	400mW
	DFN1x1-4	600mW
	DFN1.2x1.6-4	800mW
Storage Temperature(Ts)		-40°C -150°C
Lead Temperature & Time		260°C,10S
ESD(HBM)		>2000V

Note:

Heat Sink Area of PCB for DFN1x1-4 and DFN1.2x1.6-4 is recommended at least 2.5mmx4mm.

Exceed these limits to damage to the device.

Exposure to absolute maximum rating conditions may affect device reliability.

RECOMMENDED WORK CONDITIONS

Item	Min	Recommended	Max.	Unit
Input Voltage Range	2		6	V
Ambient Temperature*	-40		85	°C

*The operation ambient temperature range is verified on several test samples. Not a test condition for volume production whose test is only performed under 25°C.

ELECTRICAL CHARACTERISTICS

(Test Conditions: Cin=1uF,Cout=1uF,TA=25°C, unless otherwise specified.)

BL8568G, For Arbitrary Output Voltage

Symbol	Parameter	Conditions	Min	Typ	Max	Units
Vin	Input Voltage		2		6	V
Vout	Output Voltage	Vout>1.5V	Vin=Set Vout+1V 1mA≤Iout≤30mA	Vout x0.98	Vout	Vout X1.02
		Vout≤1.5V		Vout -0.03		Vout +0.03
Iout (Max.)	Maximun Output Current	Vin-Vout=1V	300			mA
Vdrop ¹	Dropout Voltage,Vout≥2.8V	Iout=100mA		65	100	mV
		Iout=300mA		195	300	mV
$\frac{\Delta V_{out}}{\Delta V_{in} \cdot V_{out}}$	Line Regulation	Iout=40mA 2.8V≤Vin≤6V		0.05	0.2	%/V
$\Delta V_{out} / \Delta I_{out}$	Load Regulation	Vin=Set Vout+1V 1mA≤Iout≤300mA		50	80	mV
Iss	Supply Current	Vin=Set Vout+1V		80		uA
Istandby	Supply Current (Srandby)	Vin=Set Vout+1V Vce=Vss		0.1	1.0	uA

BL8568G

$\frac{\Delta V_{out}}{\Delta T \cdot V_{out}}$	Output Voltage Temperature Coefficient	$I_{out}=30mA$		± 100		ppm/°C
PSRR	Ripple Rejection	F=1KHz, Ripple=0.5Vp-p Vin=Set Vout+1V		70		dB
Ilim	Current Limit		500			mA
Vceh	CE Input Voltage "H"		1.0		Vin	V
Vcel	CE Input Voltage "L"		0		0.5	V
Rdischarge	Discharge Resistor	CE=0, Vout=3.0V		1.5K		ohm
Rcepd	CE pin pull down resistor	CE=Vin=5V		500K		ohm

NOTE:

$V_{drop} = V_{in1} - (V_{out2} * 0.98)$ V_{out2} is the output voltage when $V_{in} = V_{out1} + 1.0V$ and $I_{out} = 300mA$.

V_{in1} is the input voltage at which the output voltage becomes 98% of V_{out1} after gradually decreasing the input voltage.

BLOCK DIAGRAM

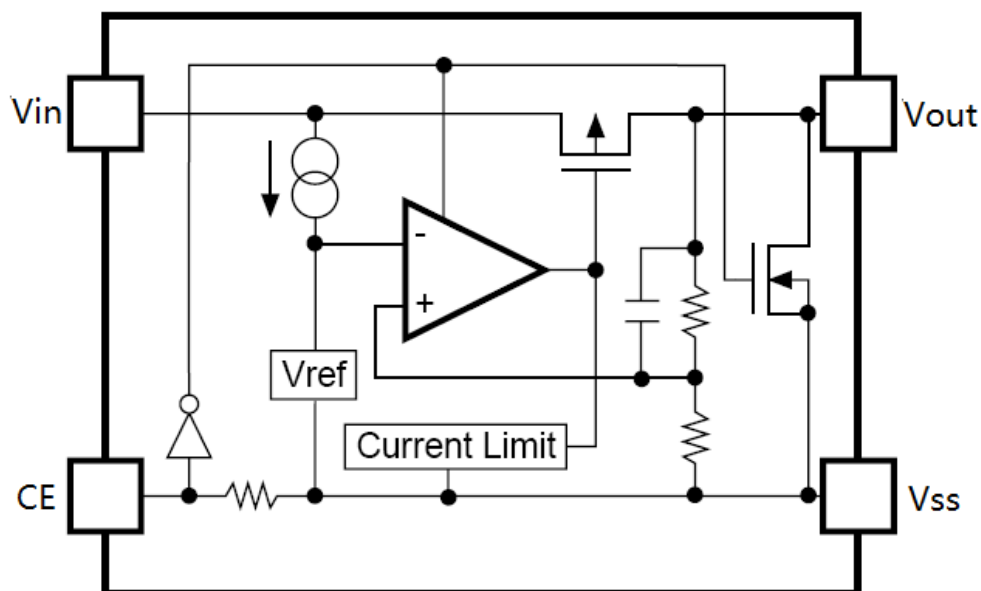

EXPLANATION

BL8568G series is a group of positive voltage output, low noise, low power consumption, low dropout voltage regulator.

BL8568G can provide output value in the range of 0.9V~4.5V every 0.1V step. It also can be customized on command.

BL8568G includes high accuracy voltage reference, error amplifier, current limit circuit and output driver module.

BL8568G has excellent load and line transient response and good temperature characteristics, which can assure the stability of chip and power system. And it uses trimming technique to guarantee output voltage accuracy within $\pm 2\%$.

TYPICAL PERFORMANCE CHARACTERISTICS ($T=25^{\circ}\text{C}$)

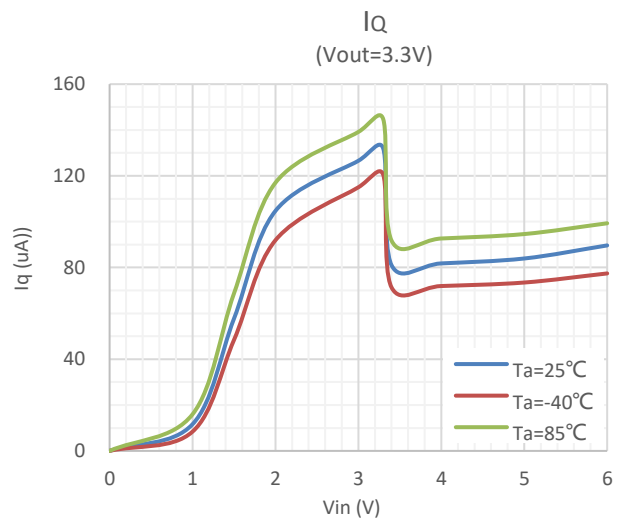
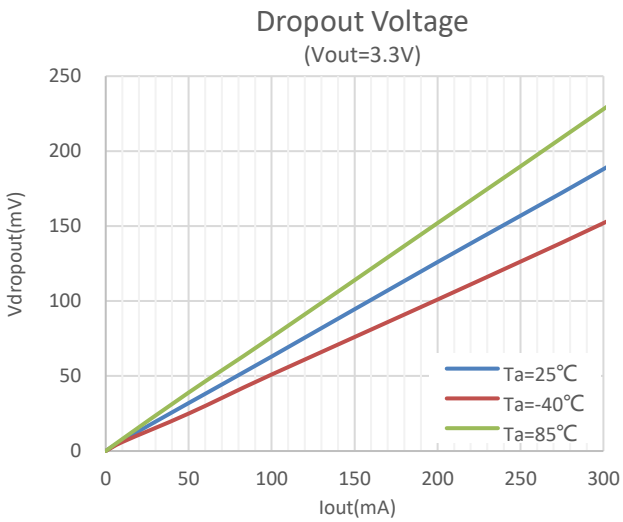
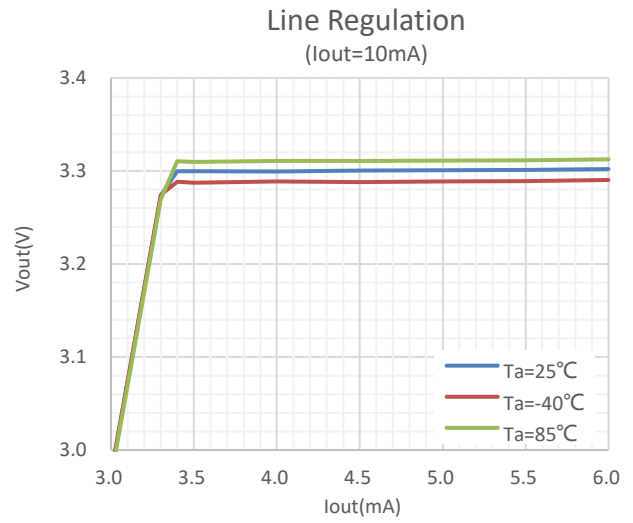
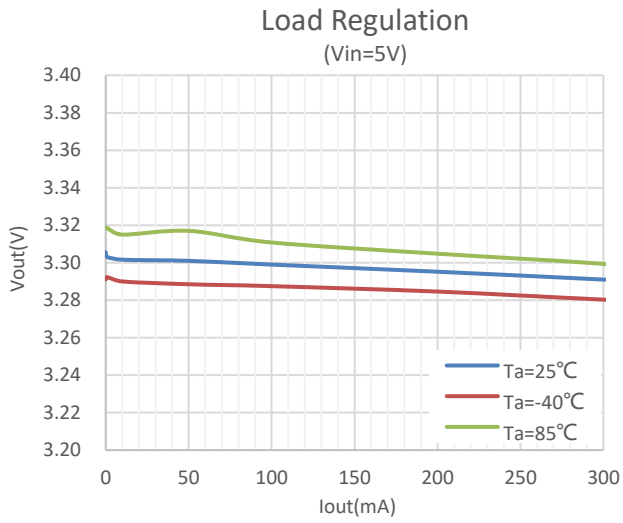

Current Limit

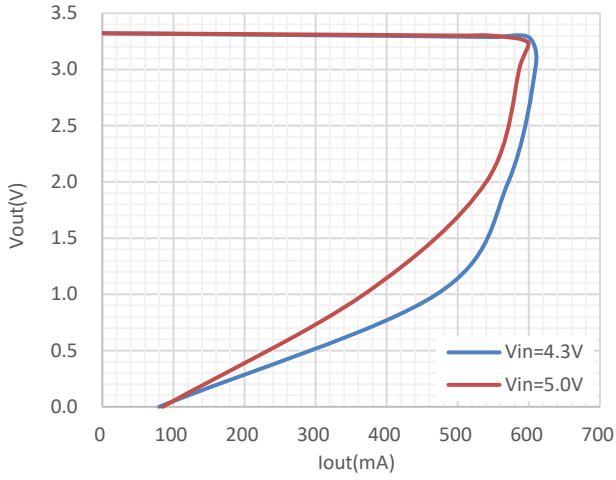

PSRR

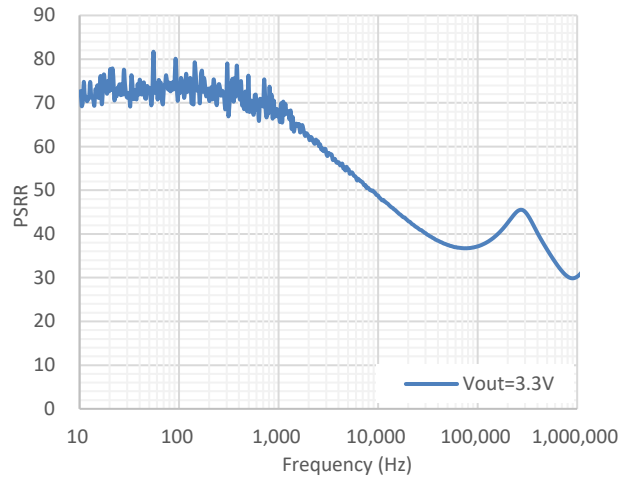

Vout vs. Temp ($V_{in}=5V, I_{out}=10mA$)

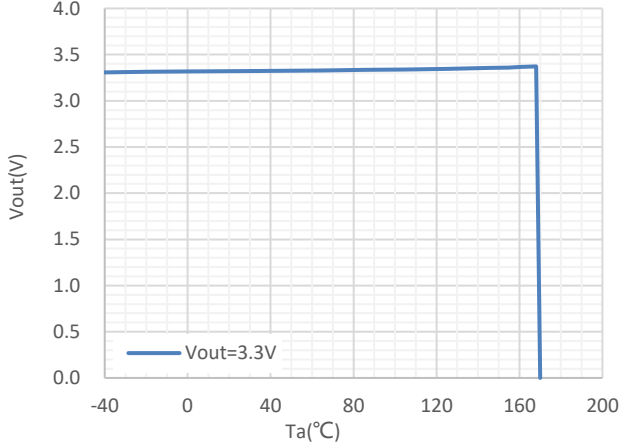

Load Transient Response

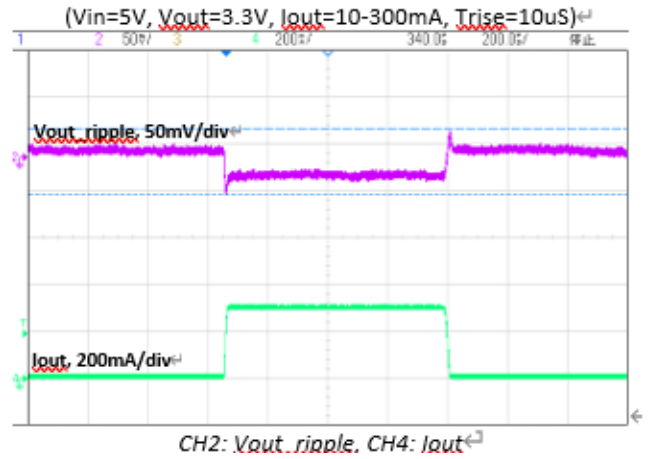

CE Chip Enable Response

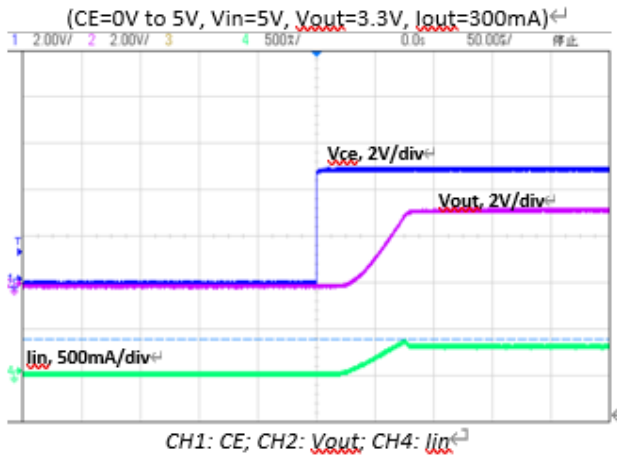

CE Chip Enable Response

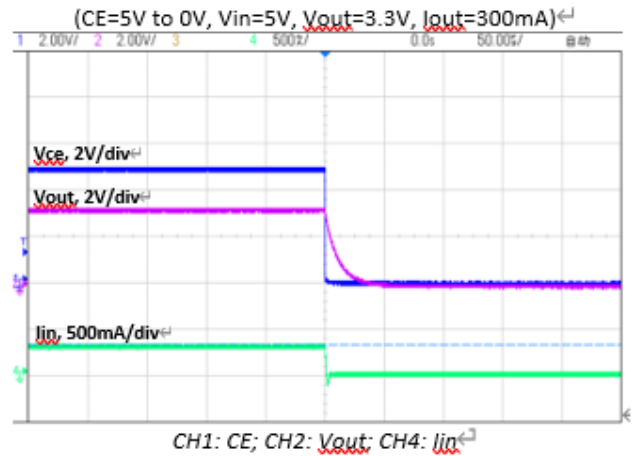

PACKAGE OUTLINE

Package	SC70-5	Devices per reel	3000Pcs
Package dimension:			
Unit: mm			

Package	SOT-23-5	Devices per reel	3000Pcs
Package Dimension:			
Unit: mm			

BL8568G

Package	TSOT-23	Devices per reel	3000Pcs
---------	---------	------------------	---------

Package dimension:

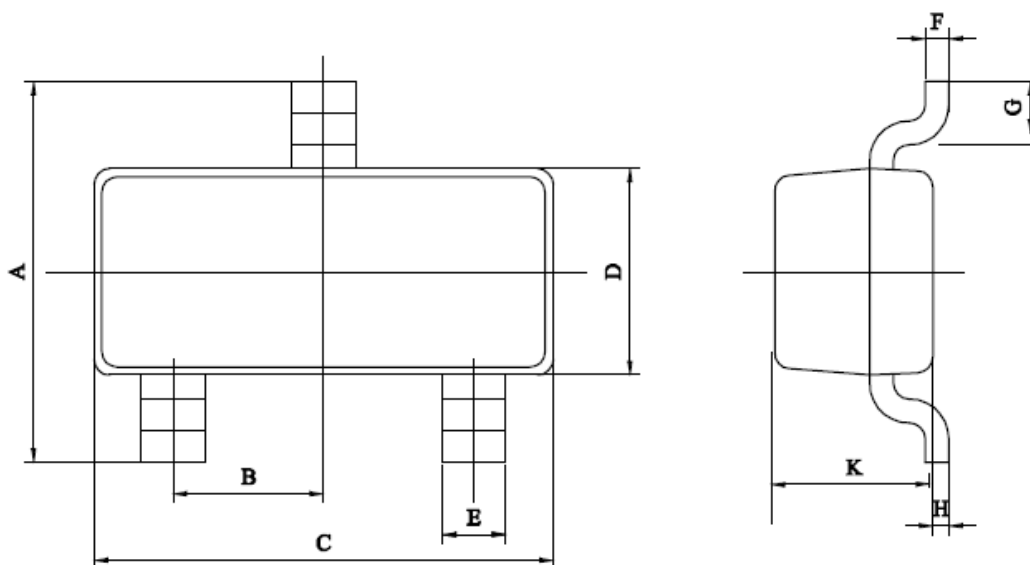

	A	B	C	D	E	F	G	H	K
出厂标准	2.4 ± 0.15	0.95 ± 0.05	2.9 ± 0.1	1.3 ± 0.1	0.40 ± 0.1	0.15 ± 0.08	0.4 ± 0.1	0.07 ± 0.07	1.00 ± 0.05

Unit: mm

Package	SOT-23-3	Devices per reel	3000Pcs
---------	----------	------------------	---------

Package Dimension:

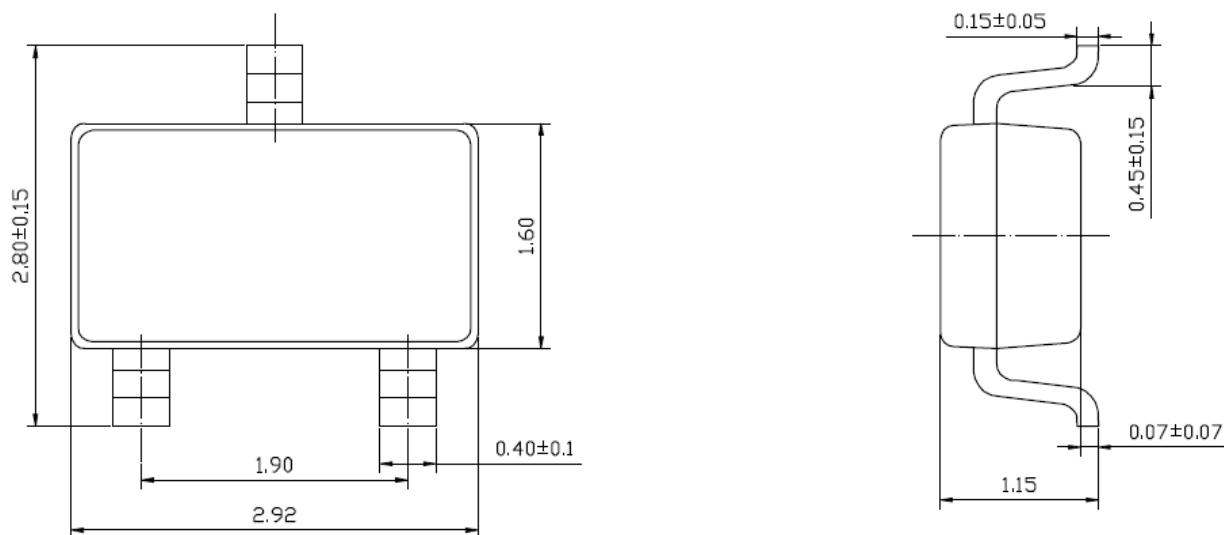

Unit: mm

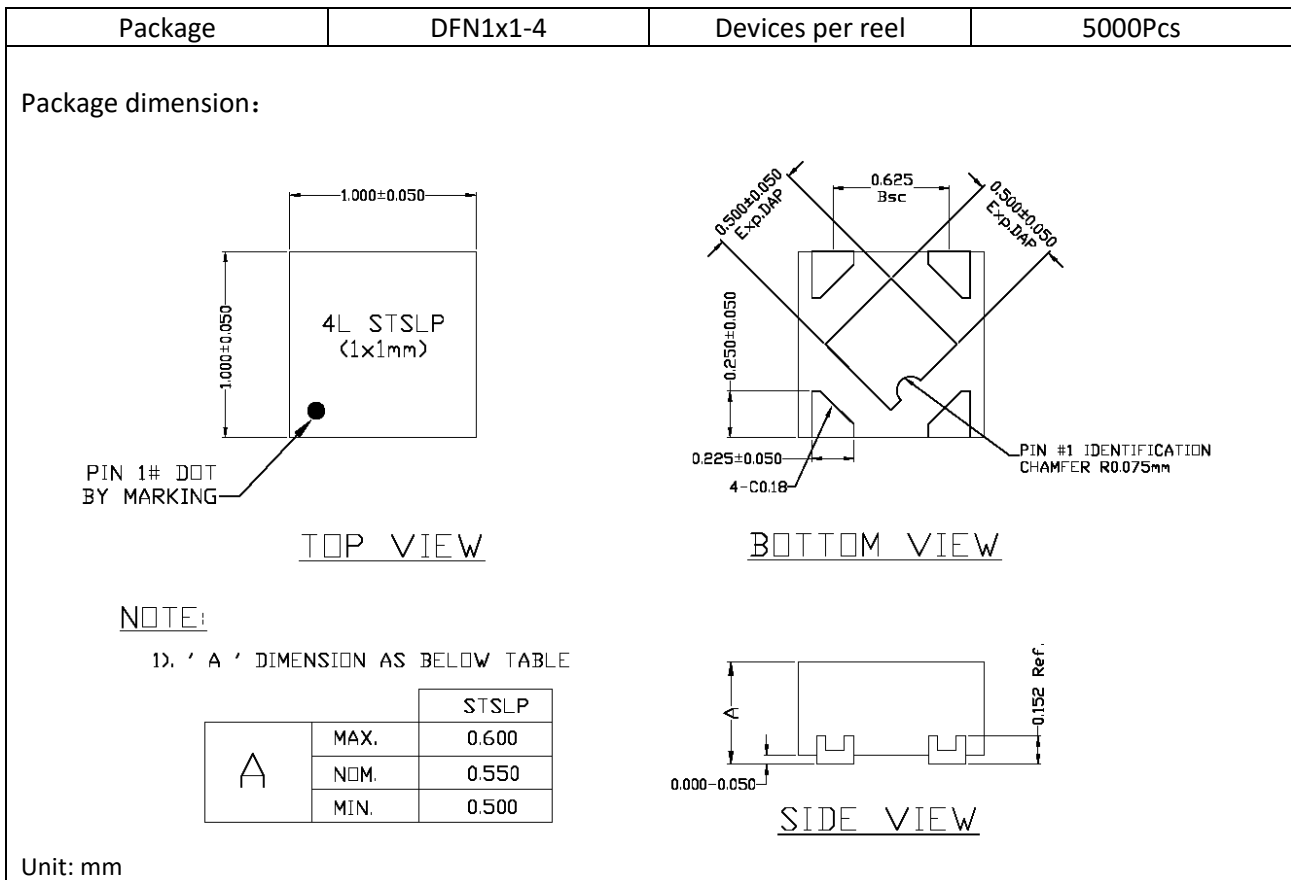

X-ON Electronics

Largest Supplier of Electrical and Electronic Components

Click to view similar products for [Linear Voltage Regulators](#) category:

Click to view products by [Belling](#) manufacturer:

Other Similar products are found below :

[LV5684PVD-XH](#) [MCDTSA6-2R](#) [L7815ACV-DG](#) [LV56801P-E](#) [UA7805CKC](#) [714954EB](#) [ZMR500QFTA](#) [BA033LBSG2-TR](#)
[NCV78M05ABDTRKG](#) [LV5680P-E](#) [L79M05T-E](#) [L78LR05D-MA-E](#) [NCV317MBTG](#) [NTE7227](#) [MP2018GZD-33-P](#) [MP2018GZD-5-P](#)
[LV5680NPVC-XH](#) [ZTS6538SE](#) [UA78L09CLP](#) [UA78L09CLPR](#) [CAT6221-PPTD-GT3](#) [MC78M09CDTRK](#) [NCV51190MNTAG](#)
[BL1118CS8TR1833](#) [BL8563CKETR18](#) [BL8077CKETR33](#) [BL9153-33CC3TR](#) [BL9161G-15BADRN](#) [BL9161G-28BADRN](#)
[BRCO7530MMC](#) [CJ7815B-TFN-ARG](#) [LM317C](#) [GM7333K](#) [GM7350K](#) [XC6206P332MR](#) [HT7533](#) [LM7912S/TR](#) [LT1764S/TR](#) [LM7805T](#)
[LM338T](#) [LM1117IMP-3.3/TR](#) [HT1117AM-3.3](#) [HT7550S](#) [AMS1117-3.3](#) [HT7150S](#) [78L12](#) [HT7550](#) [HT7533-1](#) [HXY6206I-2.5](#) [HT7133](#)