

FEATURES

- Ultra-low Noise
- Ultra-Fast Response in Line/Load Transient
- 0.01 μ A Standby Current When Shutdown
- Low Dropout: 230mV@300mA
- Wide Operating Voltage Ranges: 2.2V to 5.5V
- Low Temperature Coefficient
- Current Limiting Protection
- Thermal Shutdown Protection
- Only 1 μ F Output Capacitor Required for Stability
- High Power Supply Rejection Ratio
- Fast output discharge
- Available in SOT23-5, SC70-5 and DFN1 \times 1-4L Package

APPLICATIONS

- Cellular and Smart Phones
- Cordless Telephones
- Battery-Powered Equipment
- Laptop, Palmtops, Notebook Computers

Hand-Held Instruments

- PCMCIA Cards
- MP3/MP4/MP5 Players
- Portable Information Appliances

DESCRIPTION

The BL9161 is designed for portable applications with demanding performance and space requirements. The BL9161 performance is optimized for battery-powered systems to deliver ultra low noise and low quiescent current. Regulator ground current increases only slightly in dropout, further prolonging the battery life. The BL9161 also works with low-ESR ceramic capacitors, reducing the amount of board space necessary for power applications, critical in hand-held wireless devices. The BL9161 consumes only 0.01 μ A current in shutdown mode and has fast turn-on time (Typical 50 μ s). The other features include ultra low dropout voltage, high output accuracy, current limiting protection, and high ripple rejection ratio.

ORDERING INFORMATION

BL9161 XX X XXX

•

Package:

RN: SOT23-5
URN: SC70-5
DRN: DFN1 \times 1-4L

Enable Option:

A: active high with internal pull down

Output Voltage Accuracy

B: \pm 2%

Output Voltage:

15: 1.5V 18: 1.8V 28: 2.8V
30: 3.0V 33: 3.3V

TYPICAL APPLICATION

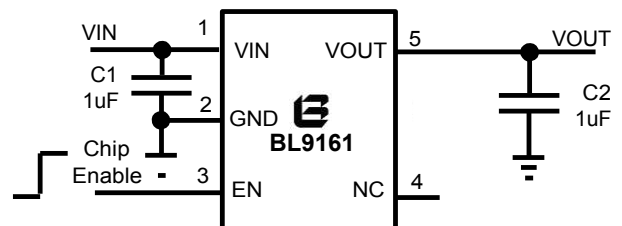

Application hints:

Output capacitor ($C2 \geq 2.2\mu$ F) is recommended in BL9161-1.5V and BL9161-1.8V application to assure the stability of circuit.

Absolute Maximum Rating (Note 1)

Input Supply Voltage (VIN)	-0.3V to +6V	Maximum Junction Temperature	150°C
EN Pin Input Voltage	-0.3V to VIN	Operating Temperature Range <small>(Note2)</small>	-40°C to 85°C
Output Voltages	-0.3V to VIN+0.3V	Storage Temperature Range	-65°C to 125°C
Output Current	300mA	Lead Temperature (Soldering, 10s)	300°C

PIN CONFIGURATIONS

SOT23-5 & SC70-5 (TOP VIEW)

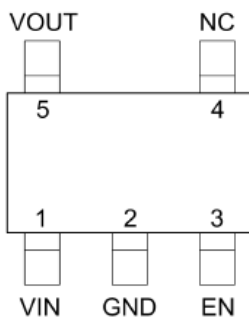

DFN1X1-4L (TOP VIEW)

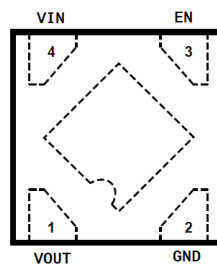

Package Marking

SOT23-5 & SC70-5

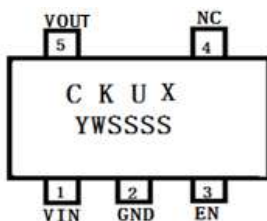

DFN1×1-4L



CKU: Chip ID
 X: Output voltage
 Y: Data code--Year
 W: Data code—Week

Thermal Resistance (Note3):

Package	θ_{JA}	θ_{JC}
SOT23-5	250°C/W	130°C/W
SC70-5	333°C/W	170°C/W

Output voltage	1.5V	1.8V	2.8V	3.0V	3.3V
X(SOT23-5 & SC70-5)	C	D	G	I	K
X(DFN1×1-4L)	E	D	C	B	A

Y	4	5	6	...	0	1	...
Year	2014	2015	2016	...	2020	2021	...

W	A	...	Y	Z	a	...	y	z
Week	1	...	25	26	27	...	51	52

Note 1: Absolute Maximum Ratings are those values beyond which the life of a device may be impaired.

Note 2: The BL9161 is guaranteed to meet performance specifications from 0°C to 70°C. Specifications over the -40°C to 85°C operating temperature range are assured by design, characterization and correlation with statistical process controls.

Note 3: Thermal Resistance is specified with approximately 1 square of 1 ozcopper.

Pin Description

SOT23-5 & SC70-5

PIN	NAME	FUNCTION
1	VIN	Power Input Voltage.
2	GND	Ground.
3	EN	Chip Enable Pin, This pin has an internal pull-down resistor
4	NC	No Connection.
5	VOUT	Output Voltage.

DFN1X1-4L

PIN	NAME	FUNCTION
1	VOUT	Output Voltage.
2	GND	Ground.
3	EN	Chip Enable Pin, This pin has an internal pull-down resistor
4	VIN	Power Input Voltage.
Exposed Pad		The exposed pad should be connected to a large ground plane to maximize thermal performance.

Block Diagram

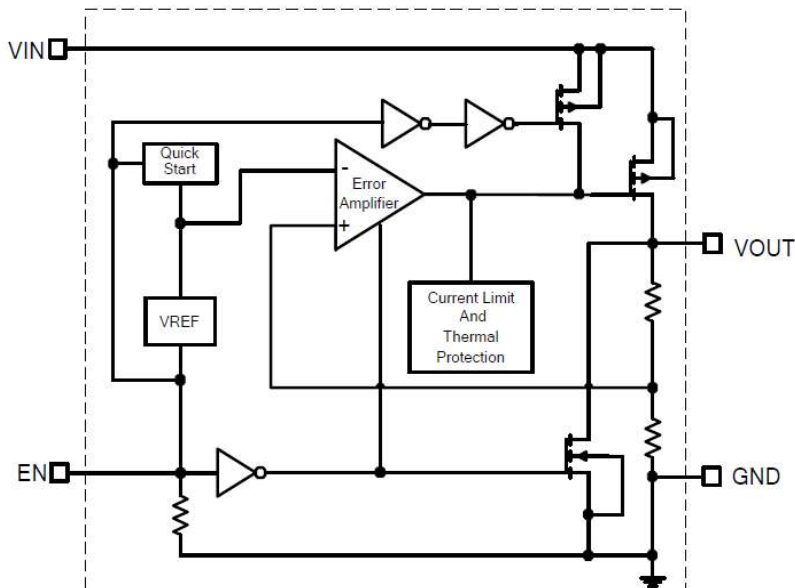

Electrical Characteristics (Note 4)

($V_{IN}=V_{OUT}+1V$, $EN=V_{IN}$, $C_{IN}=C_{OUT}=1\mu F$, $T_A=25^\circ C$, unless otherwise noted.)

Parameter	Symbol	Conditions	MIN	TYP	MAX	unit
Input Voltage	V_{IN}		2.2		5.5	V
Output Voltage Accuracy	ΔV_{OUT}	$V_{IN}=V_{OUT}+1V$, $I_{OUT}=1mA$	-2		+2	%
Current Limit	I_{LIM}	$R_{LOAD}=1\Omega$	360	450		mA
Quiescent Current	I_Q	$V_{EN}>1.2V$, $I_{OUT}=0mA$		70	110	μA
Dropout Voltage	V_{DROP}	$I_{OUT}=200mA$, $V_{OUT}=3.3V$		150	200	mV
		$I_{OUT}=300mA$, $V_{OUT}=3.3V$		230	300	
Line Regulation (Note 5)	ΔV_{LINE}	$V_{IN}=V_{OUT}+1V$ to 5.5V $I_{OUT}=1mA$		0.02	0.17	%/V
Load Regulation (Note 6)	ΔV_{LOAD}	$1mA < I_{OUT} < 300mA$		20		mV
Output Voltage (Note 7) Temperature Coefficient	$TC_{V_{OUT}}$	$I_{OUT}=1mA$		± 60		ppm/ $^\circ C$
Standby Current	I_{STBY}	$V_{EN}=GND$, Shutdown		0.01	1	μA
EN Input Bias Current	I_{IBSD}	$V_{EN}=GND$ or V_{IN}			2	μA
EN Input Threshold	Logic Low	V_{IL}	$V_{IN}=3V$ to 5.5V, Shutdown		0.4	V
	Logic High	V_{IH}	$V_{IN}=3V$ to 5.5V, Start up	1.2		V
Output Noise Voltage	e_{NO}	10Hz to 100KHz, $I_{OUT}=100mA$		150		μV_{RMS}
Power Supply Rejection Ratio	f=217Hz	PSRR	$I_{OUT}=10mA$		-78	dB
	f=1KHz				-71	
	f=10KHz				-53	
Thermal Shutdown Temperature	T_{SD}	Shutdown, Temp increasing		170		$^\circ C$
Thermal Shutdown Hysteresis	T_{SDHY}			30		$^\circ C$

Note 4: Production test at $+25^\circ C$. Specifications over the temperature range are guaranteed by design and characterization.

Note 5: Line regulation is calculated by $\Delta V_{LINE} = \left| \frac{V_{OUT1} - V_{OUT2}}{\Delta V_{IN} \times V_{OUT(normal)}} \right| \times 100$

Where V_{OUT1} is the output voltage when $V_{IN}=5.5V$, and V_{OUT2} is the output voltage when $V_{IN}=4.3V$,
 $\Delta V_{IN}=1.2V$. $V_{OUT(normal)}=3.3V$.

Note 6: Load regulation is calculated by $V_{load} = V_{out1} - V_{out2}$

Where V_{OUT1} is the output voltage when $I_{OUT}=1mA$, and V_{OUT2} is the output voltage when $I_{OUT}=300mA$.

Note 7: The temperature coefficient is calculated by $TC_{V_{OUT}} = \frac{\Delta V_{OUT}}{\Delta T \times V_{OUT}}$

Typical Performance Characteristics

Output Voltage Vs. Temperature

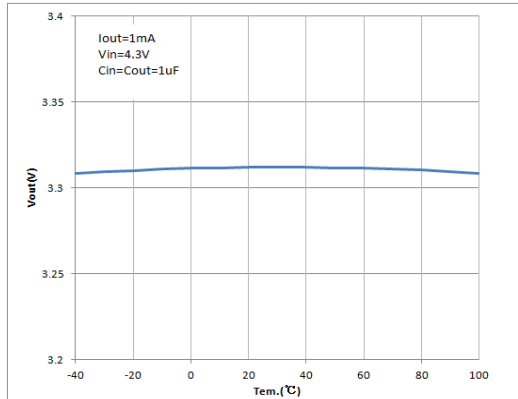

Quiescent Current Vs. Temperature

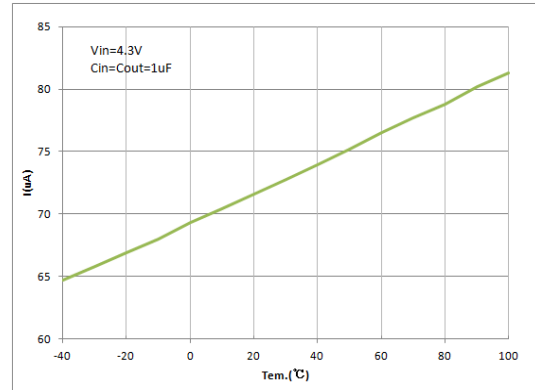

Dropout Voltage Vs. Load Current

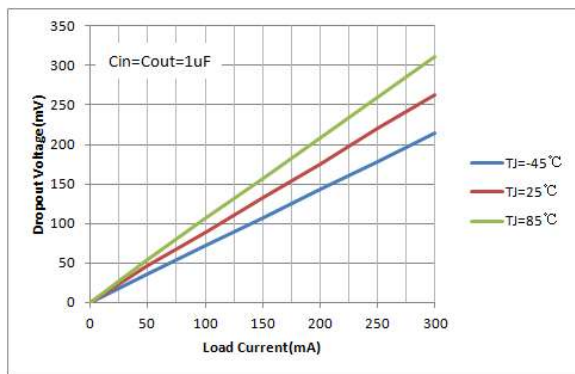

PSRR

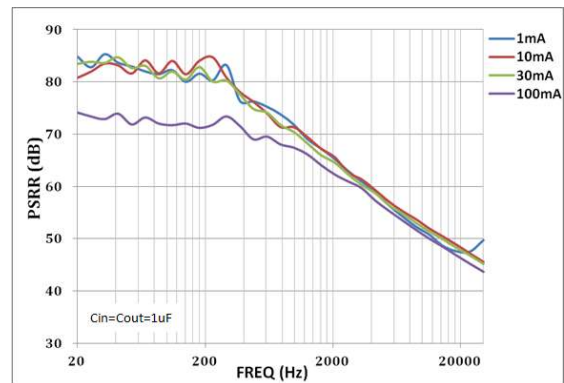

EN Pin Shutdown Threshold Vs. Temperature

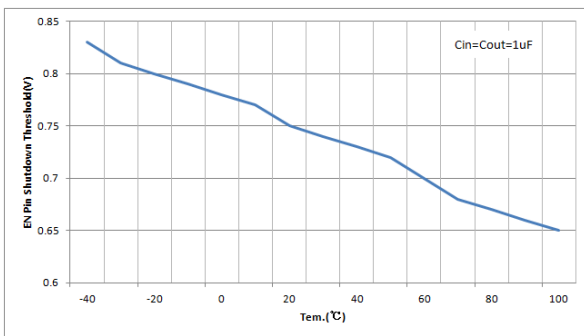

Load Transient Response

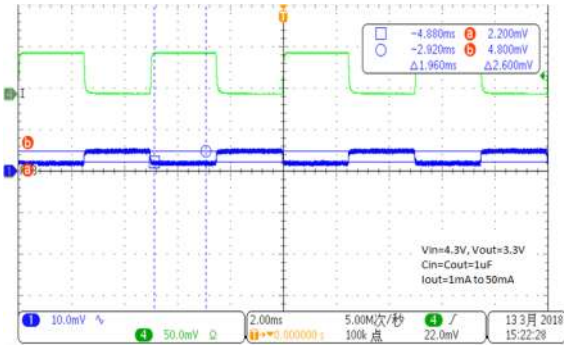

Load Transient Response

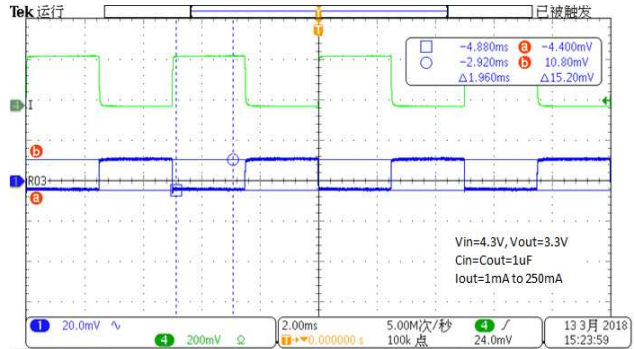

Line transient Response

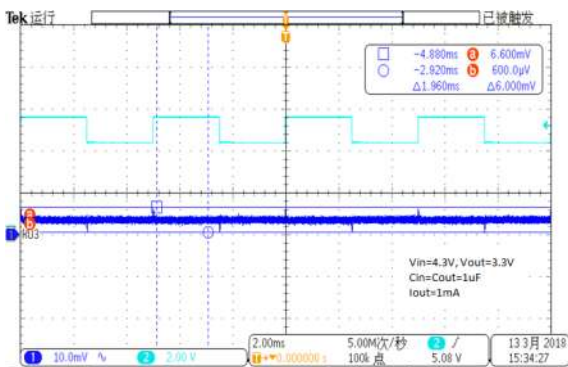

Start up

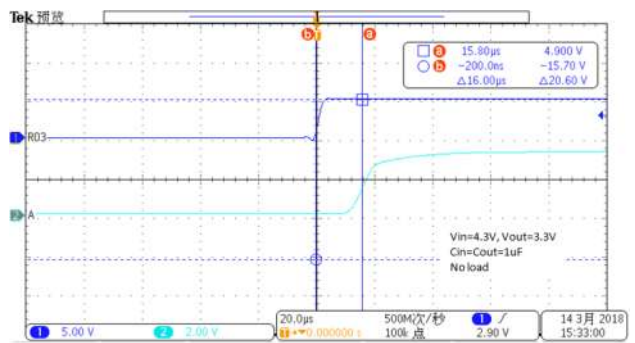

EN Pin Shutdown Response

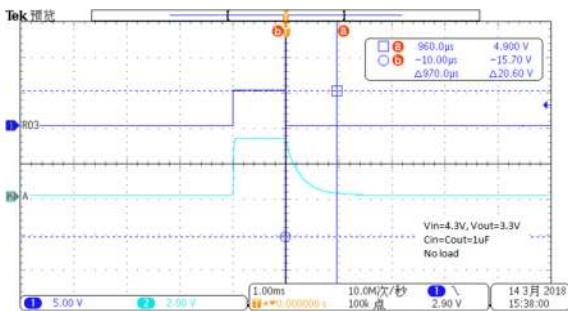

Applications Information

Like any low-dropout regulator, the external capacitors used with the BL9161 must be carefully selected for regulator stability and performance. Using a capacitor whose value is $> 1\mu\text{F}$ on the BL9161 input and the amount of capacitance can be increased without limit. The input capacitor must be located a distance of not more than 0.5 inch from the input pin of the IC and returned to a clean analog ground. Any good quality ceramic or tantalum can be used for this capacitor. The capacitor with larger value and lower ESR (equivalent series resistance) provides better PSRR and line-transient response. The output capacitor must meet both requirements for minimum amount of capacitance and ESR in all LDOs application. The BL9161 is designed specifically to work with low ESR ceramic output capacitor in space-saving and performance consideration. Using a ceramic capacitor whose value is at least $1\mu\text{F}$ with ESR is $> 25\text{m}\Omega$ on the BL9161 output ensures stability. The BL9161 still works well with output capacitor of other types due to the wide stable ESR range. Output capacitor of larger capacitance can reduce noise and improve load transient response, stability, and PSRR. The output capacitor should be located not more than 0.5 inch from the V_{OUT} pin of the BL9161 and returned to a clean analog ground.

Enable Function

The BL9161 features an LDO regulator enable/disable function. To assure the LDO regulator will switch on; the EN turn on control level must be greater than 1.2 volts. The LDO regulator will go into the shut-

down mode when the voltage on the EN pin falls below 0.4 volts. For to protect the system, the BL9161 have a quick discharge function. If the enable function is not needed in a specific application, it may be tied to V_{IN} to keep the LDO regulator in a continuously on state.

Thermal Considerations

Thermal protection limits power dissipation in BL9161. When the operation junction temperature exceeds 170°C , the OTP circuit starts the thermal shutdown function turn the pass element off. The pass element turns on again after the junction temperature cools by 30°C .

For continue operation, do not exceed absolute maximum operation junction temperature 125°C . The power dissipation definition in device is:

$$P_{\text{D}}(\text{MAX}) = (T_{\text{J}}(\text{MAX}) - T_{\text{A}}) / \theta_{\text{JA}}$$

Where $T_{\text{J}}(\text{MAX})$ is the maximum operation junction temperature 125°C , T_{A} is the ambient temperature and the θ_{JA} is the junction to ambient thermal resistance. For recommended operating conditions specification of BL9161, where $T_{\text{J}}(\text{MAX})$ is the maximum junction temperature of the die (125°C) and T_{A} is the maximum ambient temperature. The junction to ambient thermal resistance (θ_{JA} is layout dependent) for SOT-23-5 package is $250^{\circ}\text{C}/\text{W}$, on standard JEDEC 51-3 thermal test board. The maximum power dissipation at $T_{\text{A}} = 25^{\circ}\text{C}$ can be calculated by following formula:

$$P_{D(MAX)} = (125^{\circ}\text{C} - 25^{\circ}\text{C}) / 250 = 400\text{mW}$$

(SOT-23-5)

The maximum power dissipation depends on operating ambient temperature for fixed $T_{J(MAX)}$ and thermal resistance θ_{JA} . It is also useful to calculate the junction of temperature of the BL9161 under a set of specific conditions. In this example let the input voltage $V_{IN}=3.3\text{V}$, the output current $I_o=300\text{mA}$ and the case temperature $T_A=40^{\circ}\text{C}$ measured by a thermal couple during operation. The power dissipation for the $V_{OUT}=2.8\text{V}$ version of the BL9161 can be calculated as:

$$P_D = (3.3\text{V} - 2.8\text{V}) \times 300\text{mA} + 3.6\text{V} \times 100\mu\text{A}$$
$$= 150\text{mW}$$

And the junction temperature, T_J , can be calculated as follows:

$$T_J = T_A + P_D \times \theta_{JA} = 40^{\circ}\text{C} + 0.15\text{W} \times 250^{\circ}\text{C/W}$$
$$= 40^{\circ}\text{C} + 37.5^{\circ}\text{C} = 77.5^{\circ}\text{C} < T_{J(MAX)} = 125^{\circ}\text{C}$$

For this operating condition, T_J is lower than the absolute maximum operating junction temperature, 125°C , so it is safe to use the BL9161 in this configuration.

Layout considerations

To improve ac performance such as PSRR, output noise, and transient response, it is recommended that the PCB be designed with separate ground planes for V_{IN} and V_{OUT} , with each ground plane connected only at the GND pin of the device.

Package Description

SOT23-5

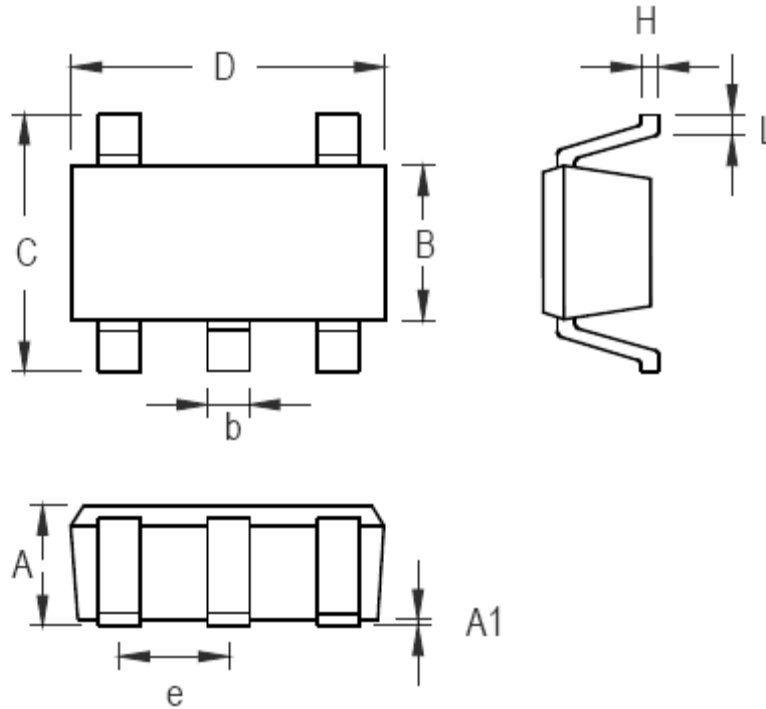

Symbol	Dimensions In Millimeters		Dimensions In Inches	
	Min	Max	Min	Max
A	0.889	1.295	0.035	0.051
A1	0.000	0.152	0.000	0.006
B	1.397	1.803	0.055	0.071
b	0.356	0.559	0.014	0.022
C	2.591	2.997	0.102	0.118
D	2.692	3.099	0.106	0.122
e	0.838	1.041	0.033	0.041
H	0.080	0.254	0.003	0.010
L	0.300	0.610	0.012	0.024

SC70-5

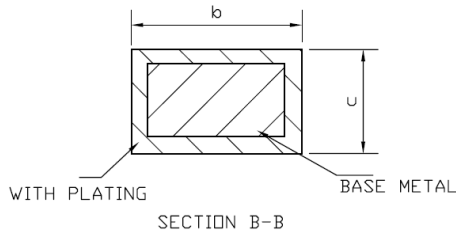
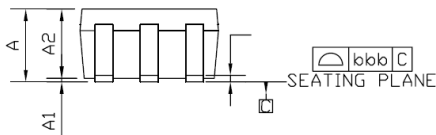
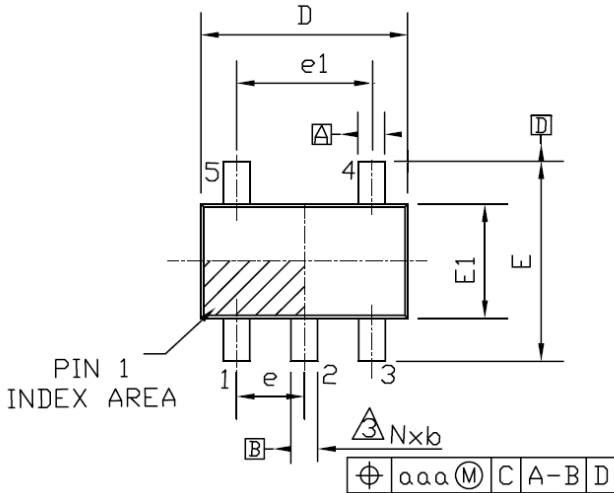

SEE VIEW A-A

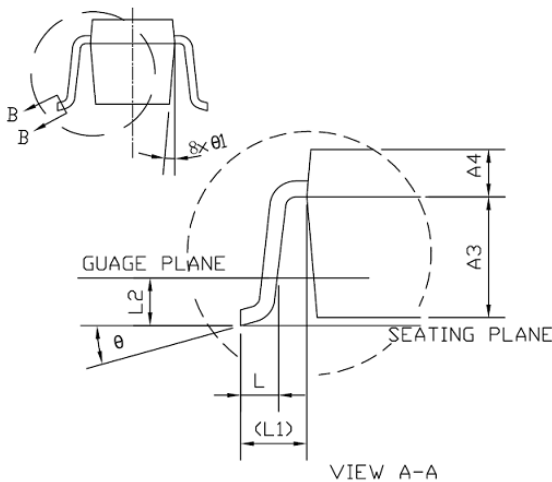

SYMBOL	IN MILLIMETERS		
	MIN	NOMAL	MAX
A	0.80	-	1.10
A1	0	-	0.10
A2	0.80	0.90	1.00
A3	0.47	0.52	0.57
A4	0.33	0.38	0.43
b	0.15	-	0.30
c	0.10	-	0.25
D	1.85	2.00	2.20
e	0.65 BSC		
e1	1.30 BSC		
E	1.80	2.10	2.40
E1	1.15	1.25	1.35
L	0.10	-	0.45
L1	0.42 REF.		
L2	0.20 BSC		
θ	0°	4°	30°
θ_1	4°	-	12°
aaa	0.10		
bbb	0.10		

DFN1×1-4L

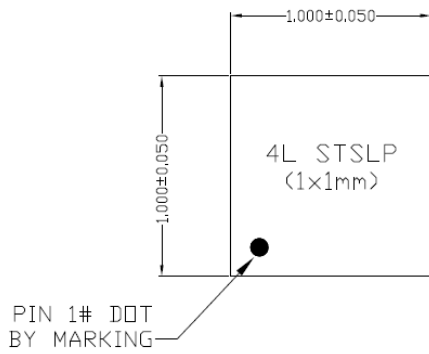

TOP VIEW

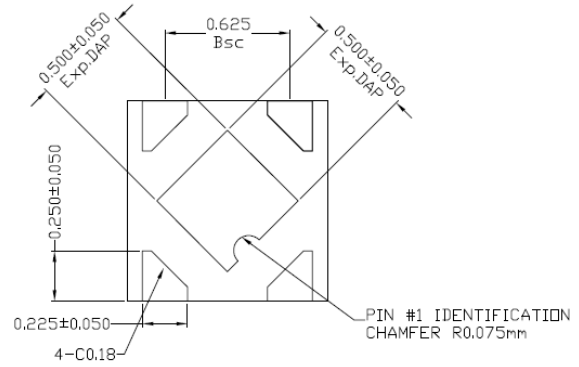

BOTTOM VIEW

NOTE:

1). ' A ' DIMENSION AS BELOW TABLE

		STSLP
A	MAX.	0.600
	NOM.	0.550
	MIN.	0.500

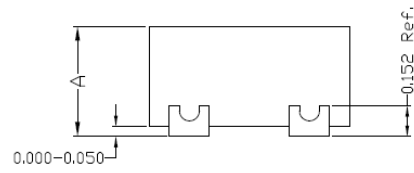

SIDE VIEW

X-ON Electronics

Largest Supplier of Electrical and Electronic Components

Click to view similar products for [Linear Voltage Regulators](#) category:

Click to view products by [Belling](#) manufacturer:

Other Similar products are found below :

[LV5684PVD-XH](#) [MCDTSA6-2R](#) [L7815ACV-DG](#) [LV56801P-E](#) [UA7805CKC](#) [714954EB](#) [ZMR500QFTA](#) [BA033LBSG2-TR](#)

[NCV78M05ABDTRKG](#) [LV5680P-E](#) [L79M05T-E](#) [L78LR05D-MA-E](#) [NCV317MBTG](#) [NTE7227](#) [MP2018GZD-33-P](#) [MP2018GZD-5-P](#)

[LV5680NPVC-XH](#) [ZTS6538SE](#) [UA78L09CLP](#) [UA78L09CLPR](#) [CAT6221-PPTD-GT3](#) [MC78M09CDTRK](#) [NCV51190MNTAG](#)

[BL1118CS8TR1833](#) [BL8563CKETR18](#) [BL8077CKETR33](#) [BL9153-33CC3TR](#) [BL9161G-15BADRN](#) [BL9161G-28BADRN](#)

[BRCO7530MMC](#) [CJ7815B-TFN-ARG](#) [LM317C](#) [GM7333K](#) [GM7350K](#) [XC6206P332MR](#) [HT7533](#) [LM7912S/TR](#) [LT1764S/TR](#) [LM7805T](#)

[LM338T](#) [LM1117IMP-3.3/TR](#) [HT1117AM-3.3](#) [HT7550S](#) [AMS1117-3.3](#) [HT7150S](#) [78L12](#) [HT7550](#) [HT7533-1](#) [HXY6206I-2.5](#) [HT7133](#)