

30V P-Channel Power MOSFET

DESCRIPTION

The BLM10P03 uses advanced trench technology to provide excellent $R_{DS(ON)}$, low gate charge. It can be used in a wide variety of applications.

Application

- Power switching application
- Hard switched and High frequency circuits
- Battery Protection

KEY CHARACTERISTICS

- $V_{DS} = -30V, I_D = -24A$ (PDFN3.3*3.3)
 $I_D = -30A$ (PDFN5*6)
 $I_D = -15A$ (SOP8)
 $I_D = -40A$ (TO-252)
- $R_{DS(ON)} < 10m\Omega @ V_{GS} = -10V$
 $R_{DS(ON)} < 15m\Omega @ V_{GS} = -4.5V$
- High density cell design for lower R_{dson}
- Excellent package for good heat dissipation

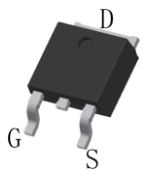

TO-252-2L

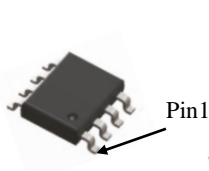

SOP8

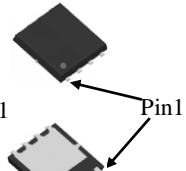

PDFN 5*6

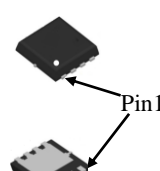

PDFN 3.3*3.3

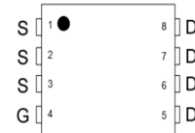

Package Top View

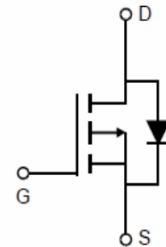

Schematic diagram

Package Marking And Ordering Information

Device Marking	Ordering Codes	Package	Product Code	Packing
M10P03	BLM10P03-D	TO-252-2L	BLM10P03	Tape Reel
M10P03	BLM10P03-R	PDFN3.3*3.3	BLM10P03	Tape Reel
M10P03	BLM10P03-E	SOP8	BLM10P03	Tape Reel
M10P03	BLM10P03-Q	PDFN5*6	BLM10P03	Tape Reel

Absolute Maximum Ratings ($T_A = 25^\circ C$ unless otherwise noted)

Parameter	Symbol	Limit	Unit
Drain-Source Voltage	V_{DS}	-30	V
Gate-Source Voltage	V_{GS}	± 20	V
Drain Current-Continuous	I_D (PDFN3.3*3.3)	-24	A
	I_D (PDFN5*6)	-30	A
	I_D (SOP8)	-15	A
	I_D (TO-252)	-40	A
Drain Current-Pulsed ^(Note 1)	I_{DM} (PDFN3.3*3.3)	-96	A
	I_{DM} (PDFN5*6)	-120	A
	I_{DM} (SOP8)	-60	A
	I_{DM} (TO-252)	-160	A

Maximum Power Dissipation($T_c=25^{\circ}\text{C}$)	P_D (PDFN3.3*3.3)	8.4	W
	P_D (PDFN5*6)	13	W
	P_D (SOP8)	3.3	W
	P_D (TO-252)	23.2	W
Operating Junction and Storage Temperature Range	T_J, T_{STG}	-55 To 150	$^{\circ}\text{C}$

Thermal Characteristic

Thermal Resistance, Junction-to-Ambient	$R_{\theta JC}$ (PDFN3.3*3.3)	15.0	$^{\circ}\text{C/W}$
	$R_{\theta JC}$ (PDFN5*6)	9.6	$^{\circ}\text{C/W}$
	$R_{\theta JC}$ (SOP8)	38.3	$^{\circ}\text{C/W}$
	$R_{\theta JC}$ (TO-252)	5.4	$^{\circ}\text{C/W}$

Electrical Characteristics ($T_A=25^{\circ}\text{C}$ unless otherwise noted)

Parameter	Symbol	Condition	Min	Typ	Max	Unit
Off Characteristics						
Drain-Source Breakdown Voltage	BV_{DSS}	$V_{GS}=0V, I_D=-250\mu\text{A}$	-30	-	-	V
Zero Gate Voltage Drain Current	I_{DSS}	$V_{DS}=-30V, V_{GS}=0V$	-	-	-1	μA
Gate-Body Leakage Current	I_{GSS}	$V_{GS}=\pm 20V, V_{DS}=0V$	-	-	± 100	nA
On Characteristics						
Gate Threshold Voltage	$V_{GS(th)}$	$V_{DS}=V_{GS}, I_D=-250\mu\text{A}$	-1.0	-1.5	-2.4	V
Drain-Source On-State Resistance ^(Note 2)	$R_{DS(on)}$	$V_{GS}=-10V, I_D=-17A$	-	8	10	m Ω
		$V_{GS}=-4.5V, I_D=-13A$	-	12	15	m Ω
Forward Transconductance	g_{FS}	$V_{DS}=-5V, I_D=-17A$	-	43	-	S
Dynamic Characteristics						
Input Capacitance	C_{iss}	$V_{DS}=-15V, V_{GS}=0V,$ $f=1.0\text{MHz}$	-	2000	-	pF
Output Capacitance	C_{oss}		-	290	-	pF
Reverse Transfer Capacitance	C_{rss}		-	270	-	pF
Switching Characteristics ^(Note 3)						
Turn-on Delay Time	$t_{d(on)}$	$V_{DD}=-15V, I_D=-17A,$ $V_{GS}=-10V, R_{GEN}=3\Omega$	-	10	-	nS
Turn-on Rise Time	t_r		-	8	-	nS
Turn-Off Delay Time	$t_{d(off)}$		-	43	-	nS
Turn-Off Fall Time	t_f		-	18	-	nS
Total Gate Charge	Q_g	$V_{DS}=-15V, I_D=-17A$ $V_{GS}=-10V$	-	36	-	nC
Gate-Source Charge	Q_{gs}		-	5.3	-	nC
Gate-Drain Charge	Q_{gd}		-	8.8	-	nC
Drain-Source Diode Characteristics						
Diode Forward Voltage	V_{SD}	$V_{GS}=0V, I_S=-1A$	-	-	-1.2	V

Notes:

1. Repetitive Rating: Pulse width limited by maximum junction temperature.
2. Pulse Test: Pulse Width $\leq 300\mu\text{s}$, Duty Cycle $\leq 2\%$.
3. Guaranteed by design, not subject to production.

Characteristics Curves

Figure 7 Gate-Charge Characteristics

Figure 8 Capacitance Characteristics

Figure 9a Maximum Forward Biased Safe Operation Area (PDFN3.3*3.3)

Figure 9b Maximum Forward Biased Safe Operation Area (PDFN5*6)

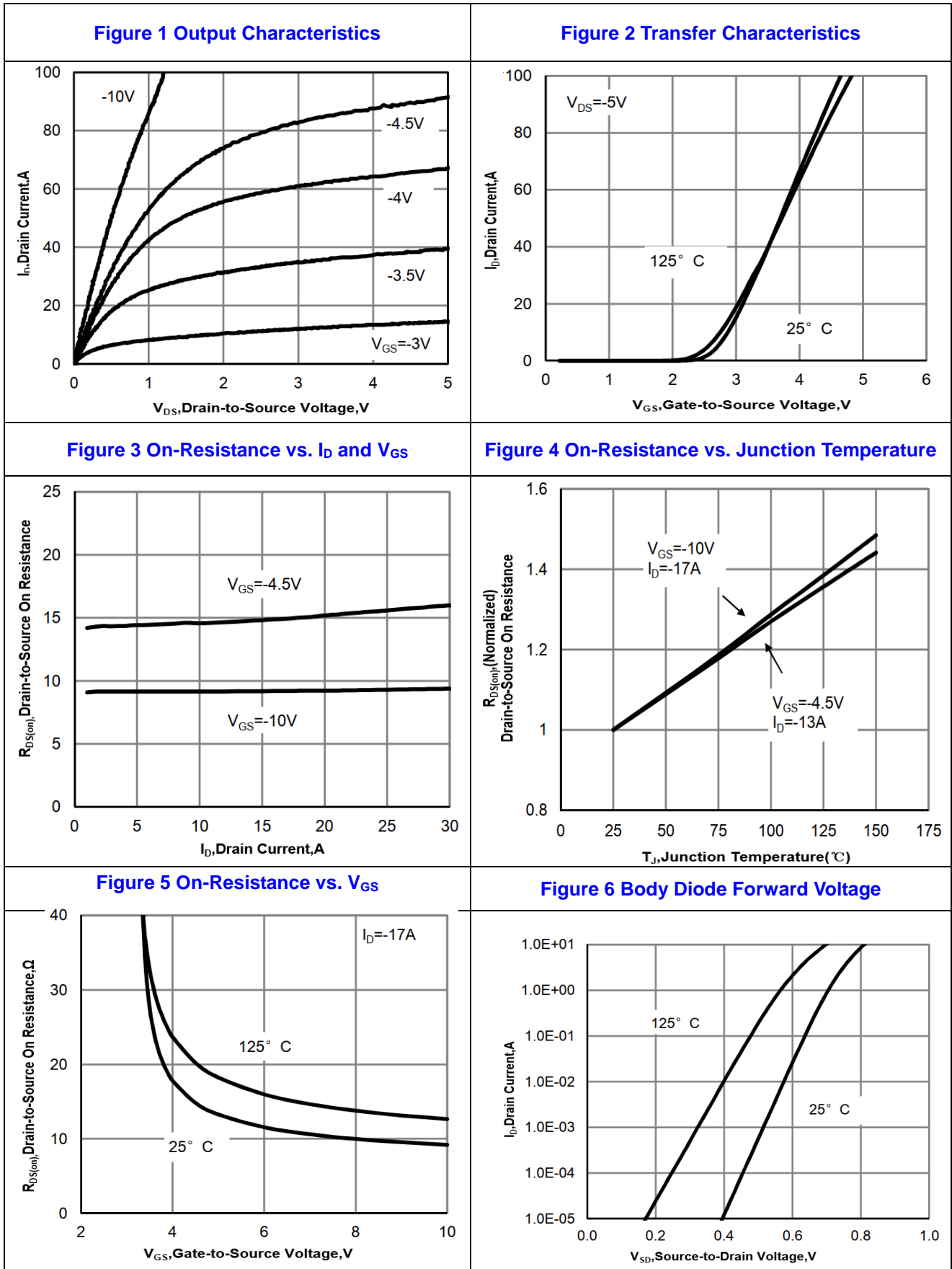
Figure 9c Maximum Forward Biased Safe Operation Area (SOP8)

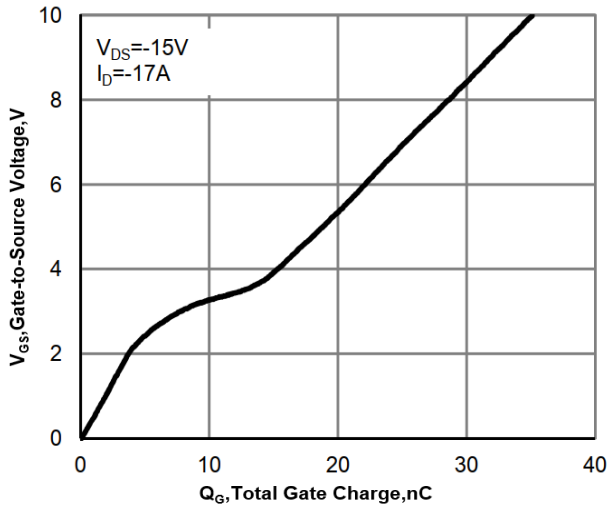
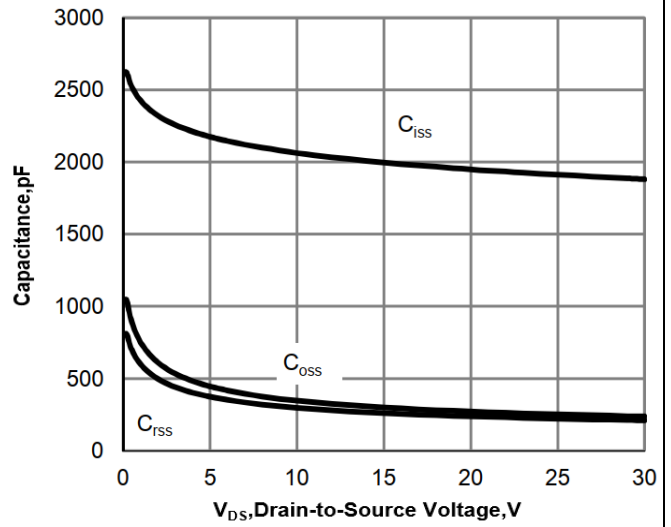
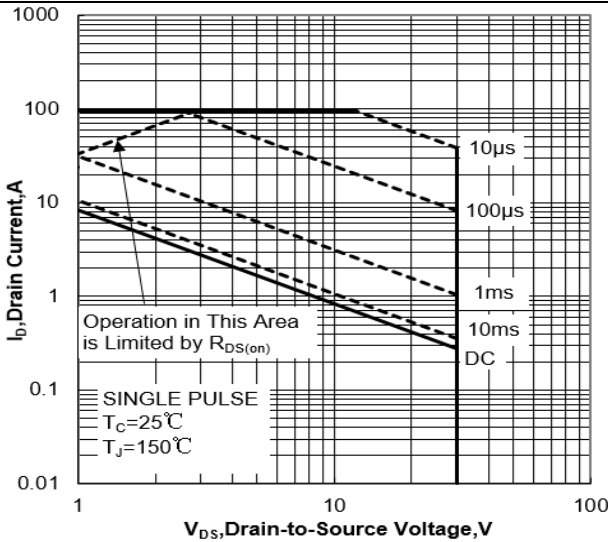
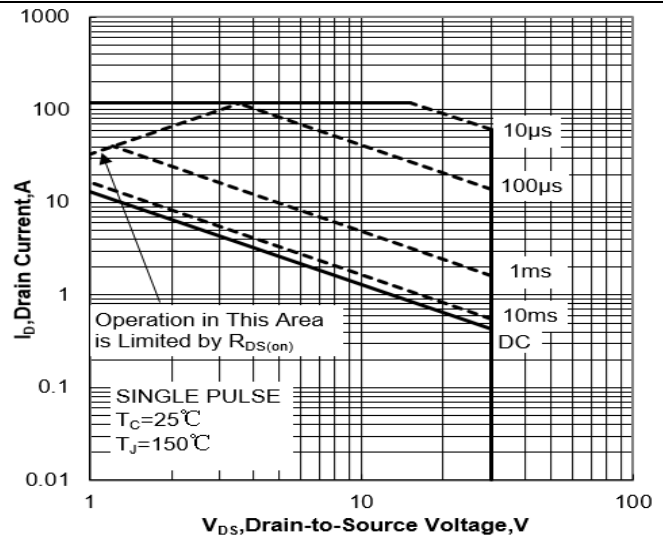
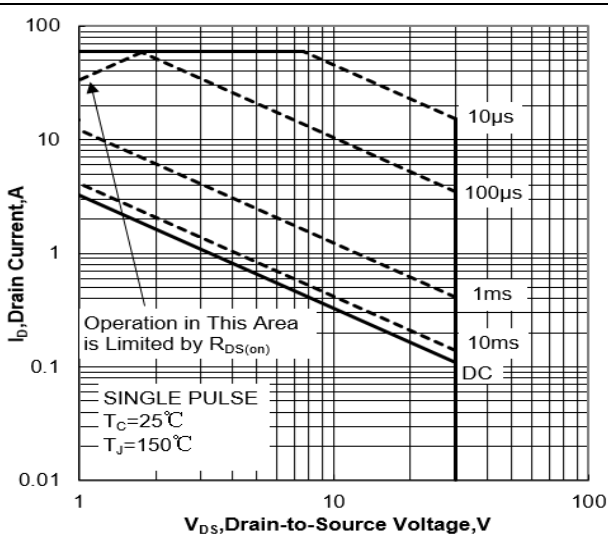
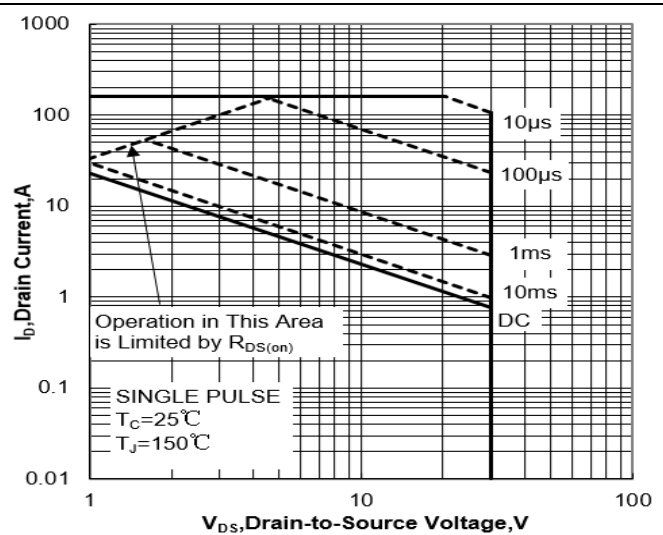
Figure 9d Maximum Forward Biased Safe Operation Area (TO-252)

Figure 10a Single Pulse Power Rating Junction-to-Ambient (PDFN3.3*3.3)

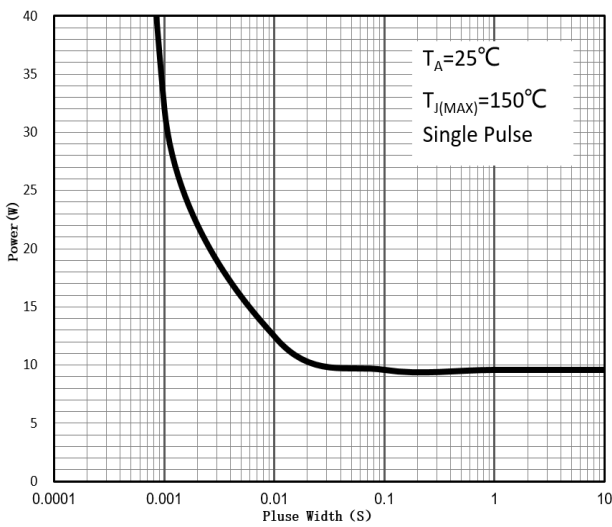

Figure 10b Single Pulse Power Rating Junction-to-Ambient (PDFN5*6)

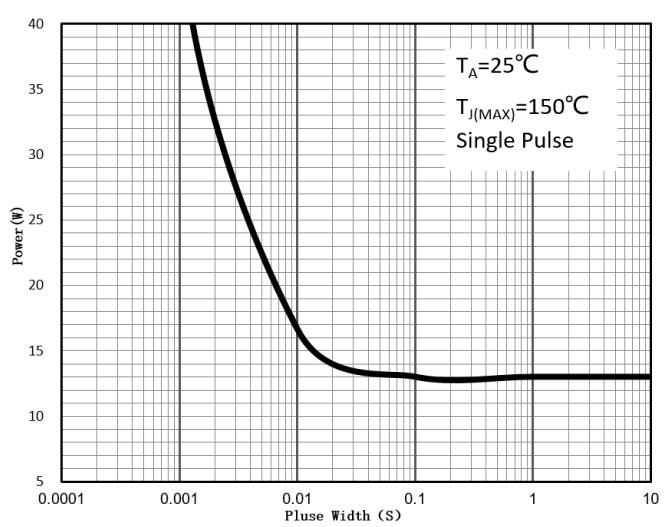

Figure 10c Single Pulse Power Rating Junction-to-Ambient (SOP8)

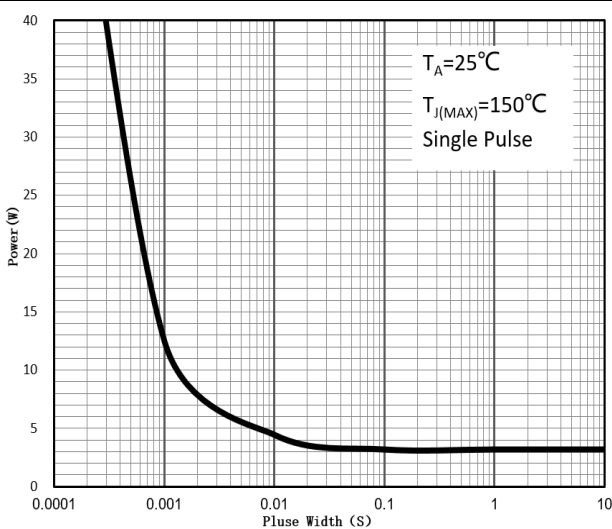

Figure 10d Single Pulse Power Rating Junction-to-Ambient (TO-252)

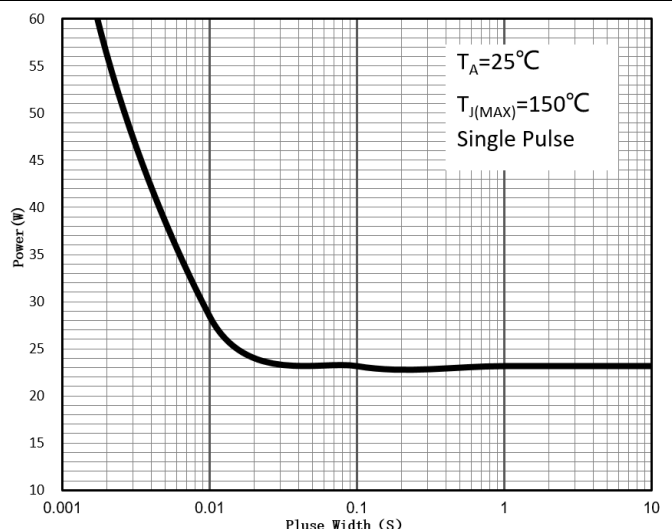

Figure 11a Normalized Maximum Transient Thermal Impedance (PDFN3.3*3.3)

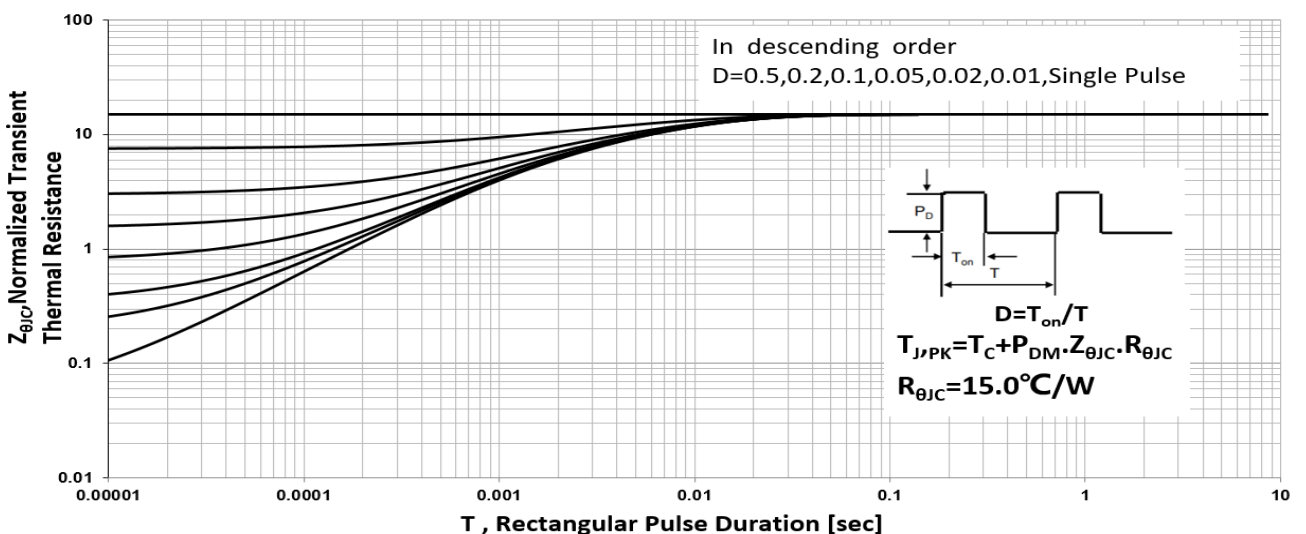

Figure 11b Normalized Maximum Transient Thermal Impedance (PDFN 5*6)

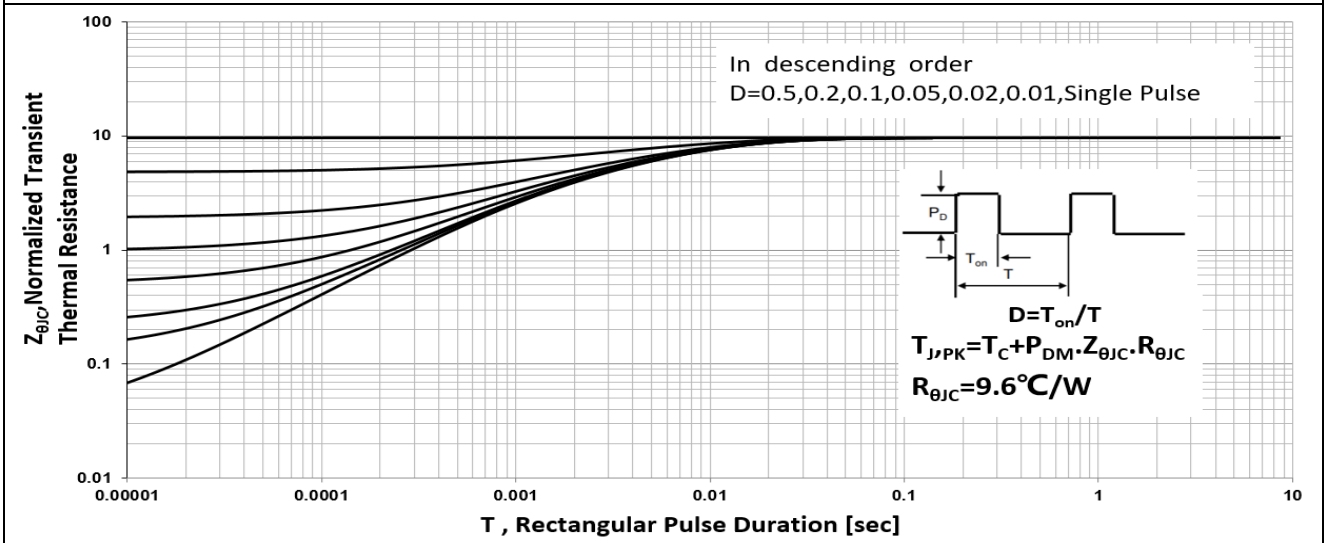

Figure 11c Normalized Maximum Transient Thermal Impedance (SOP8)

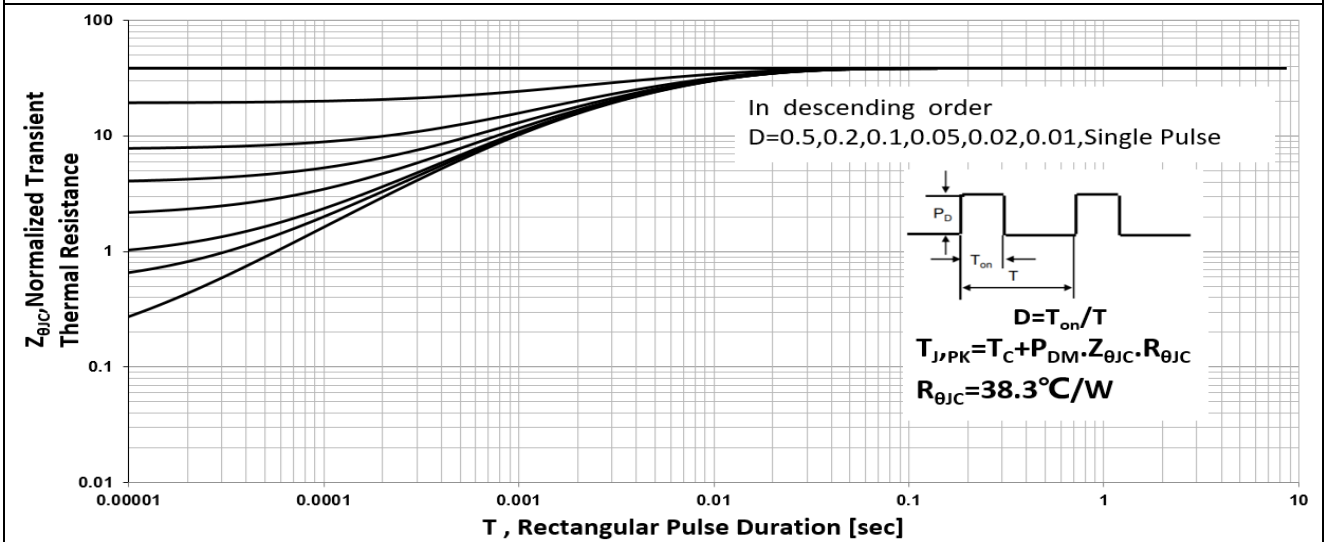
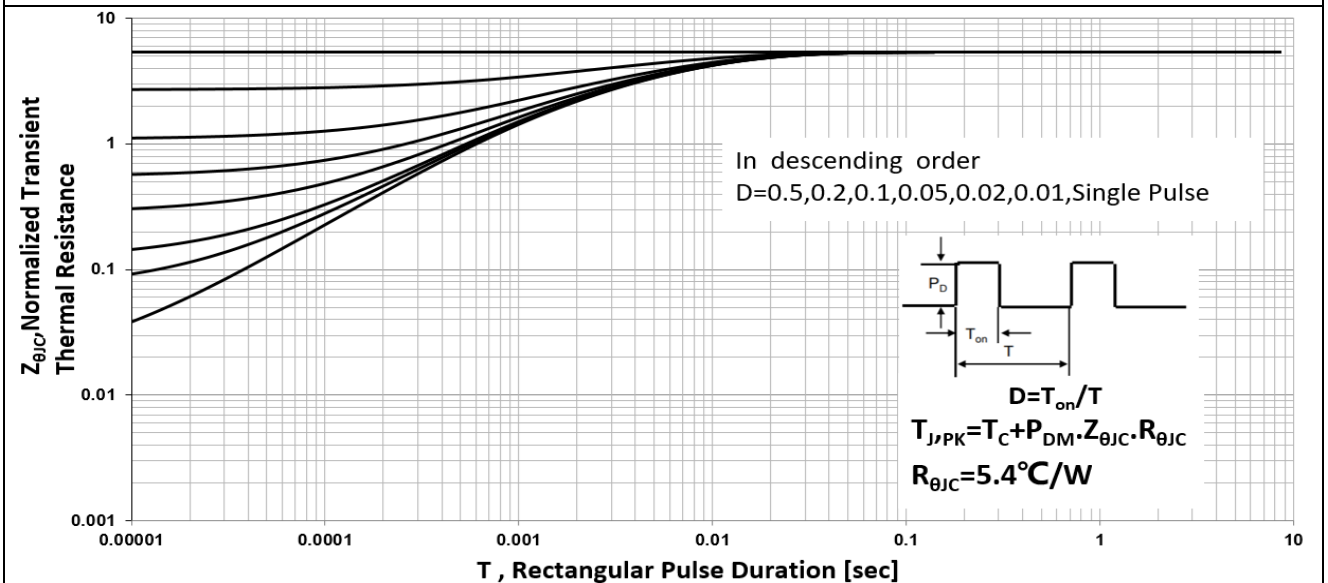
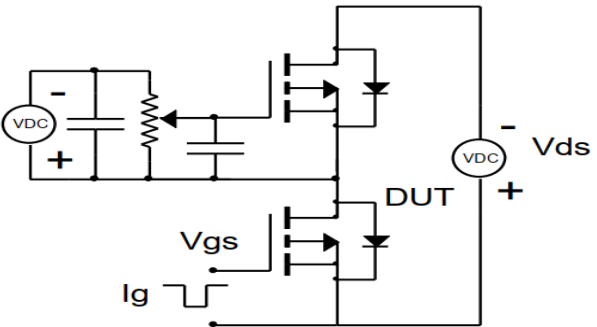
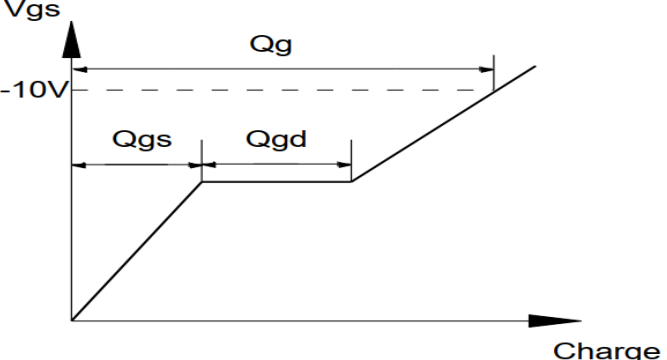
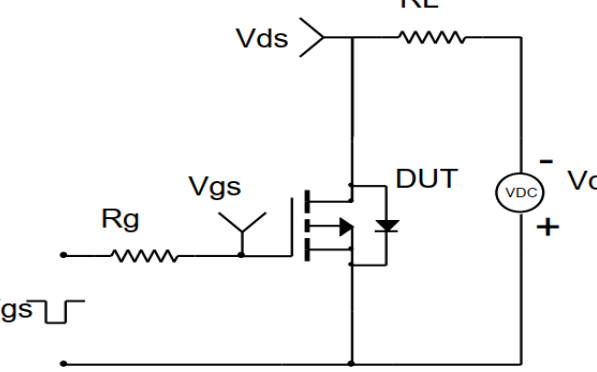
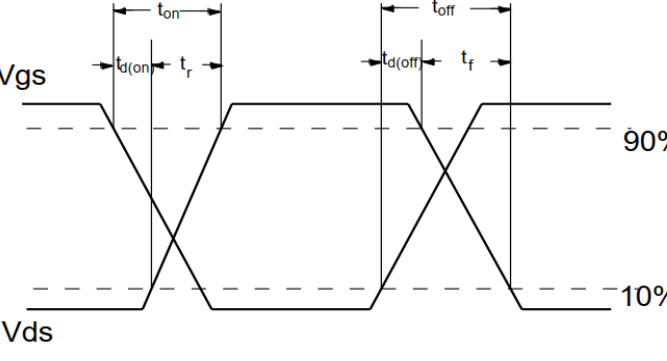
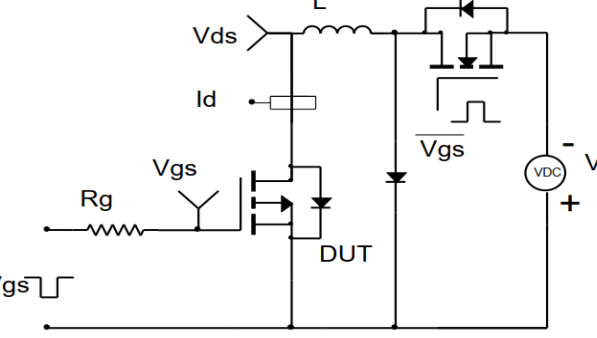
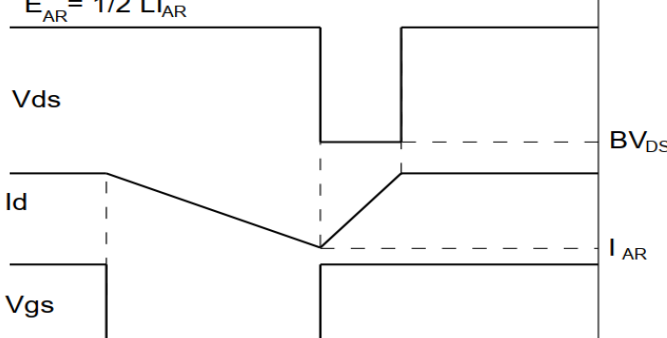
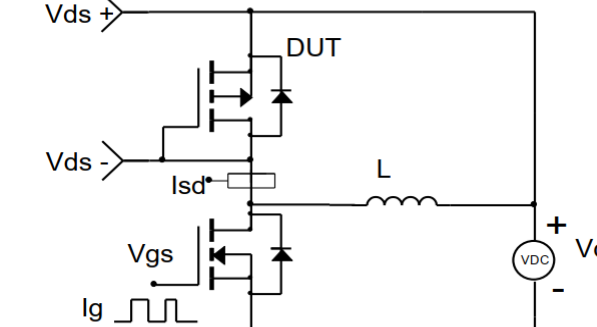
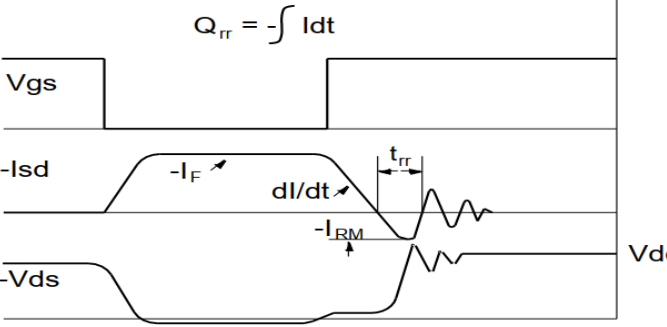
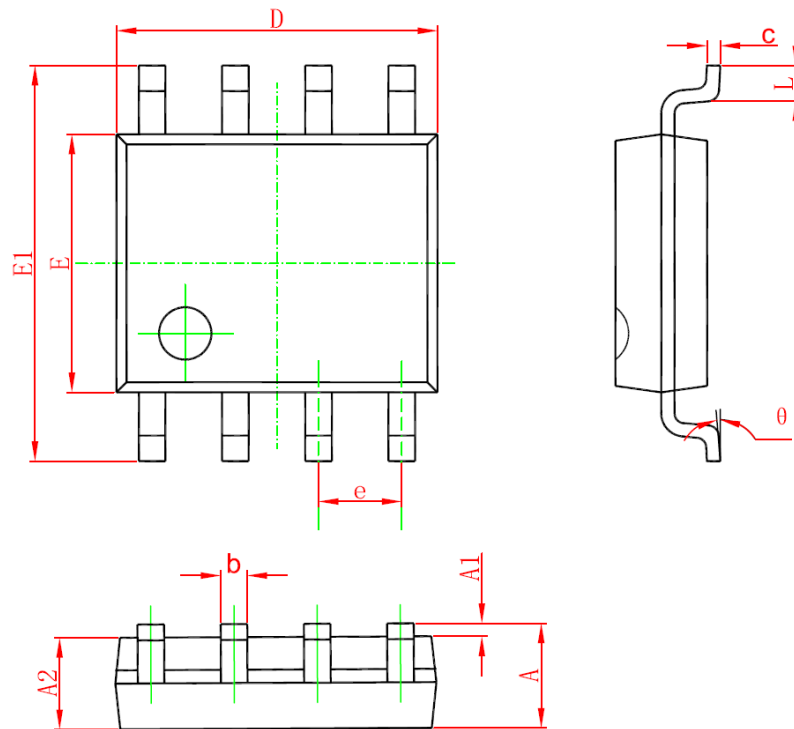

Figure 11d Normalized Maximum Transient Thermal Impedance (TO-252)



Test Circuit and Waveform

Gate Charge Test Circuit	Gate Charge Test Waveform
 <p>The diagram shows a MOSFET circuit for gate charge testing. A VDC source is connected to the drain through a resistor. The gate is driven by a pulse source Vgs through a resistor Rg. The drain current Id is measured. The device under test (DUT) is a MOSFET.</p>	 <p>The waveform shows the gate voltage Vgs over time. It starts at -10V, rises to a plateau, and then falls. The total gate charge is Qg, the gate-to-source charge is Qgs, and the gate-to-drain charge is Qgd. The x-axis is labeled 'Charge'.</p>
Resistive Switching Test Circuit	Resistive Switching Test Waveforms
 <p>The diagram shows a MOSFET circuit with a load resistor RL. The drain is connected to VDD through RL. The gate is driven by a pulse source Vgs through a resistor Rg. The drain voltage Vds is measured. The device under test (DUT) is a MOSFET.</p>	 <p>The waveforms show the gate voltage Vgs and drain voltage Vds over time. Vgs is a square wave. Vds shows a trapezoidal shape during switching. Key parameters are labeled: ton (turn-on delay), tr (rise time), toff (turn-off delay), and tf (fall time). The 90% and 10% levels are indicated for the Vds transitions.</p>
Unclamped Inductive Switching (UIS) Test Circuit	Unclamped Inductive Switching (UIS) Test Waveforms
 <p>The diagram shows a MOSFET circuit with an inductive load L. The drain is connected to VDD through L. The gate is driven by a pulse source Vgs through a resistor Rg. The drain current Id is measured. The device under test (DUT) is a MOSFET.</p>	 <p>The waveforms show the drain voltage Vds, drain current Id, and gate voltage Vgs over time. Vds shows a sharp spike during switching. The energy stored in the inductor is given by the equation $E_{AR} = 1/2 L I_{AR}^2$. The peak drain voltage is BV_{DSS} and the average drain current is I_{AR}.</p>
Diode Recovery Test Circuit	Diode Recovery Test Waveforms
 <p>The diagram shows a MOSFET circuit with an inductive load L. The drain is connected to VDD through L. The gate is driven by a pulse source Vgs through a resistor Rg. The drain current Id is measured. The device under test (DUT) is a MOSFET.</p>	 <p>The waveforms show the gate voltage Vgs, drain current Id, and drain voltage Vds over time. Vgs is a square wave. Id shows a trapezoidal shape during switching. Vds shows a sharp spike during switching. The reverse recovery time trr is indicated. The equation $Q_{rr} = \int Idt$ is shown. The peak reverse current is -I_{RM} and the average reverse current is -I_F.</p>

Package Description

Symbol	Dimensions Millimeters		Dimensions In Inches	
	Min	Max	Min	Max
A	1.350	1.750	0.053	0.069
A1	0.100	0.250	0.004	0.010
A2	1.350	1.550	0.053	0.061
b	0.330	0.510	0.013	0.020
c	0.170	0.250	0.006	0.010
D	4.700	5.100	0.185	0.200
E	3.800	4.000	0.150	0.157
E1	5.800	6.200	0.228	0.244
e	1.270 (BSC)		0.050 (BSC)	
L	0.400	1.270	0.016	0.050
θ	0°	8°	0°	8°

SOP8 Package

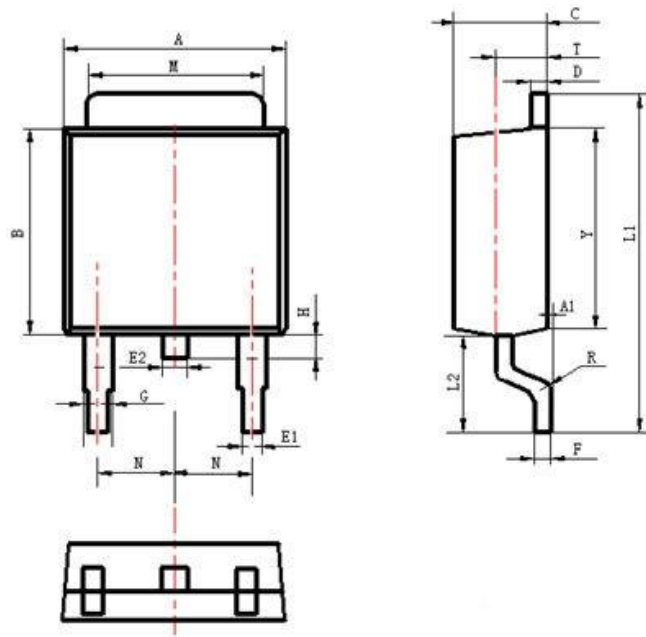

Items	Values(mm)	
	MIN	MAX
A	6.30	6.90
A1	0	0.13
B	5.70	6.30
C	2.10	2.50
D	0.30	0.60
E1	0.60	0.90
E2	0.70	1.00
F	0.30	0.60
G	0.70	1.20
L1	9.60	10.50
L2	2.70	3.10
H	0.60	1.00
M	5.10	5.50
N	2.09	2.49
R	0.3	
T	1.40	1.60
Y	5.10	6.30

TO-252-2L Package

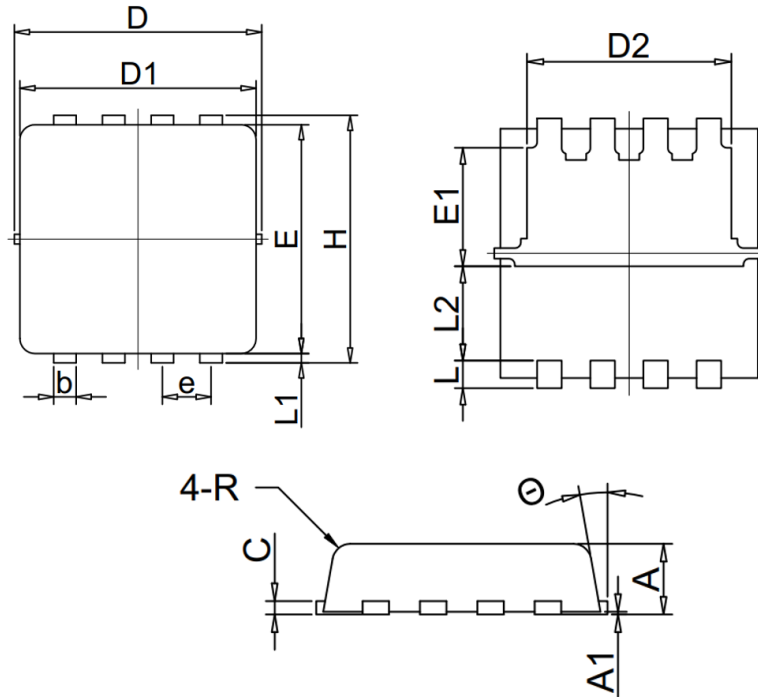

SYMBOL	MIN	NOM	MAX
A	0.70	0.80	0.90
A1	0.00	0.03	0.05
b	0.24	0.30	0.35
c	0.152REF		
D	3.25	3.32	3.40
D1	3.05	3.15	3.25
D2	2.40	2.50	2.60
E	3.00	3.10	3.20
E1	1.35	1.45	1.55
e	0.65BSC		
H	3.20	3.30	3.40
L	0.30	0.40	0.15
L1	0.10	0.15	0.20
L2	1.13REF		
R	0.20REF		
θ	6°	10°	14°

PDFN3.3*3.3 Package

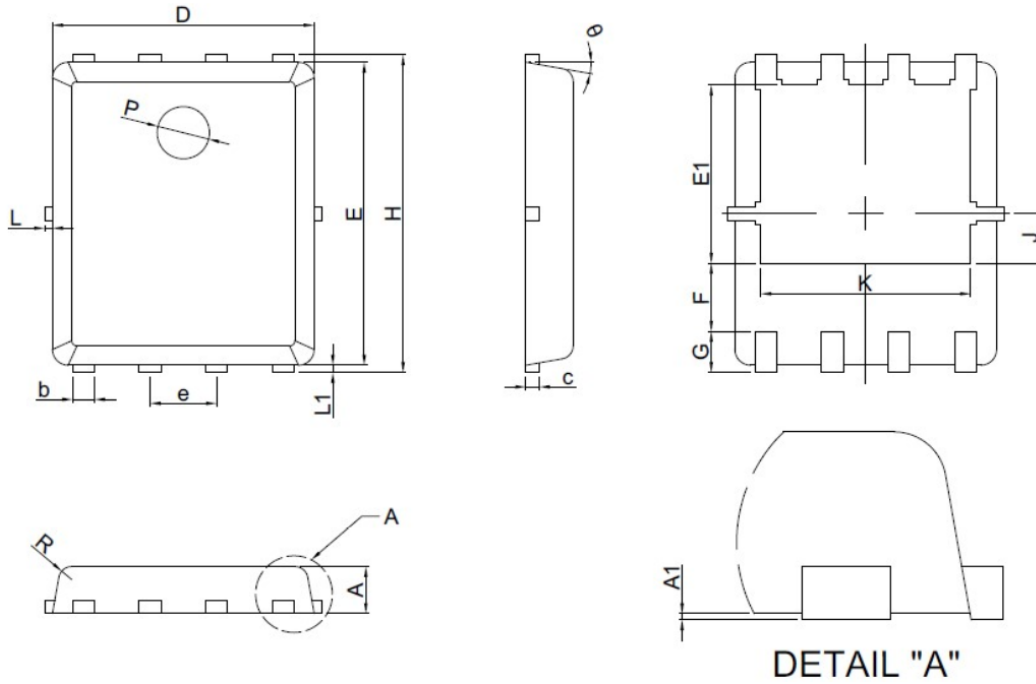

SYMBOL	MIN	NORMAL	MAX
A	0.8	0.9	1.0
A1	0.00	0.03	0.05
b	0.35	0.42	0.49
c	0.254REF		
D	4.9	5.0	5.1
F	1.40REF		
E	5.7	5.8	5.9
e	1.27BSC		
H	5.95	6.08	6.20
L1	0.10	0.14	0.18
G	0.60REF		
K	4.00REF		
L	-----	-----	0.15
J	0.95BSC		
P	1.00REF		
E1	3.35	3.40	3.65
θ	6°	10°	14°
R	0.25REF		

PDFN 5*6 Package

NOTE:

1. Exceeding the maximum ratings of the device in performance may cause damage to the device, even the permanent failure, which may affect the dependability of the machine. Please do not exceed the absolute maximum ratings of the device when circuit designing.
2. When installing the heat sink, please pay attention to the torsional moment and the smoothness of the heat sink.
3. MOSFETs is the device which is sensitive to the static electricity, it is necessary to protect the device from being damaged by the static electricity when using it.
4. Shanghai Belling reserves the right to make changes in this specification sheet and is subject to change without prior notice.

CONTACT:**上海贝岭股份有限公司 (总部)**

地址: 上海市宜山路 810 号

邮编: 200233

电话: 021-24261000

产品业务咨询及技术支持

电话: 021-24261326

传真 2: 021-64852222

邮箱 2: marketing@belling.com.cn

上海贝岭深圳分公司 (华南区)

地址: 深圳市福田区中心区民田路新华保险大厦 1510 室

邮编: 518031

电话: 0755-33336776 0755-33336770

传真: 0755-33336788

上海贝岭北京办事处 (华北区)

地址: 北京市西城区新华里 16 号院锦官苑小区 10 号楼 1 单元 1505 室

邮编: 100044

电话: 010-64179374

传真: 010-8835 9236

X-ON Electronics

Largest Supplier of Electrical and Electronic Components

Click to view similar products for [MOSFET](#) category:

Click to view products by [Belling](#) manufacturer:

Other Similar products are found below :

[614233C](#) [648584F](#) [MCH3443-TL-E](#) [MCH6422-TL-E](#) [FDPF9N50NZ](#) [NTNS3A92PZT5G](#) [IRFD120](#) [IRFF430](#) [JANTX2N5237](#) [2N7000](#)
[AOD464](#) [2SK2267\(Q\)](#) [2SK2545\(Q,T\)](#) [405094E](#) [423220D](#) [MIC4420CM-TR](#) [VN1206L](#) [614234A](#) [715780A](#) [SSM6J414TU,LF\(T](#) [751625C](#)
[IPS70R2K0CEAKMA1](#) [BSF024N03LT3 G](#) [PSMN4R2-30MLD](#) [TK31J60W5,S1VQ\(O](#) [2SK2614\(TE16L1,Q\)](#) [DMN1017UCP3-7](#)
[EFC2J004NUZTDG](#) [FCAB21350L1](#) [P85W28HP2F-7071](#) [DMN1053UCP4-7](#) [NTE2384](#) [NTE2969](#) [NTE6400A](#) [DMC2700UDMQ-7](#)
[DMN2080UCB4-7](#) [DMN61D9UWQ-13](#) [US6M2GTR](#) [DMN31D5UDJ-7](#) [SSM6P54TU,LF](#) [DMP22D4UFO-7B](#) [IPS60R3K4CEAKMA1](#)
[DMN1006UCA6-7](#) [DMN16M9UCA6-7](#) [STF5N65M6](#) [IRF40H233XTMA1](#) [IPSA70R950CEAKMA1](#) [IPSA70R2K0CEAKMA1](#) [STU5N65M6](#)
[C3M0021120D](#)