

High-voltage High-current Darlington Transistor Arrays

Features

- 500-mA-Rated Collector Current(single output)
- High-Voltage Outputs : 50V
- Output Clamp Diodes
- Inputs Compatible With Various Types of Logic
- Relay-Driver Applications
- SOP16 package

General Description

The ULN2003 is high-voltage high-current Darlington transistor arrays each containing seven open collector common emitter pairs. Each pair is rated at 500mA. Suppression diodes are included for inductive load driving, the inputs and outputs are pinned in opposition to simplify board layout.

These devices are capable of driving a wide range of loads including solenoids, relays, DC motors, LED displays, filament lamps, thermal print-heads and high-power buffers.

Pin Assignments

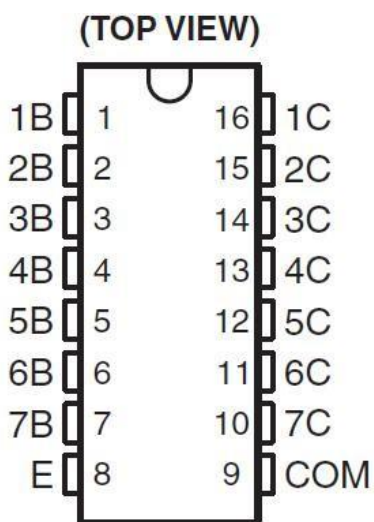

Connection Diagram

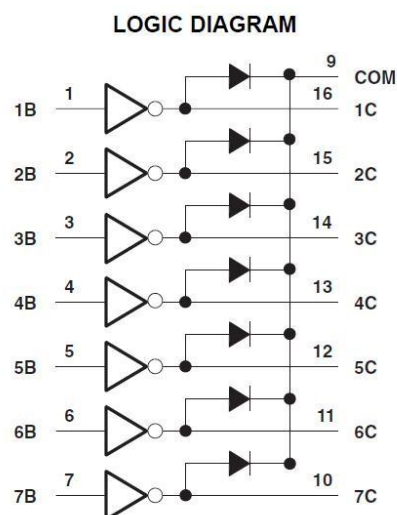

Ordering Information

Order No.	Package	Packing
ULN2003	SOP16	Tape and Reel, 3500

Pin Descriptions

Pin Number	Pin Name	Function
1	1B	Input pair1
2	2B	Input pair1
3	3B	Input pair1
4	4B	Input pair1
5	5B	Input pair1
6	6B	Input pair1
7	7B	Input pair1
8	E	Common Emitter (ground)
9	COM	Common Clamp Diodes
10	7C	Output pair7
11	6C	Output pair6
12	5C	Output pair5
13	4C	Output pair4
14	3C	Output pair3
15	2C	Output pair2
16	1C	Output pair1

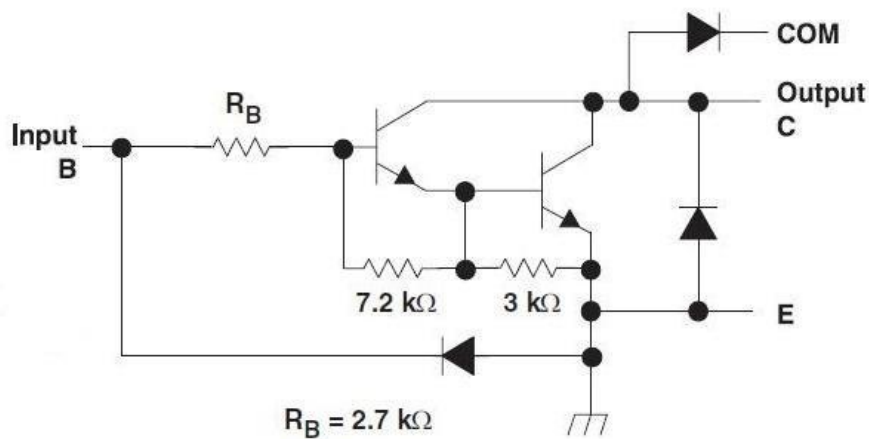
Functional Block Diagram

Note: All resistor values shown are nominal.

The collector-emitter diode is a parasitic structure and should not be used to conduct current. If the collector(s) go below ground an external Schottky diode should be added to clamp negative undershoots.

Absolute Maximum Ratings ⁽¹⁾

At 25°C free-air temperature (unless otherwise noted)

Symbol	Parameter		Min	Max	Unit
V _{CC}	Collector to emitter voltage			50	V
V _R	Clamp diode reverse voltage(2)			50	V
V _I	Input voltage(2)			30	V
I _{CP}	Peak collector current	See typical characteristics		500	mA
I _{OK}	Output clamp current			500	mA
I _{TE}	Total emitter-terminal current			-2.5	A
T _A	Operating free-air temperature range		-20	70	°C
θ _{JA}	Thermal Resistance Junction-to-Ambient(3)			63	°C/W
θ _{JC}	Thermal Resistance Junction-to-Case(4)			12	
T _J	Operating virtual junction temperature			150	°C
T _{STG}	Storage temperature range		-65	150	°C
ESD	Human Body Mode		--	3000	V

- (1) Stresses beyond those listed under "absolute maximum ratings" may cause permanent damage to the device. These are stress ratings only, and functional operation of the device at these or any other conditions beyond those indicated under "recommended operating conditions" is not implied. Exposure to absolute-maximum-rated conditions for extended periods may affect device reliability.
- (2) All voltage values are with respect to the emitter/substrate terminal E, unless otherwise noted.
- (3) Maximum power dissipation is a function of T_{J(max)}, θ_{JA}, and T_A. The maximum allowable power dissipation at any allowable ambient temperature is $PD = (T_J(max) - T_A)/\theta_{JA}$. Operating at the absolute maximum T_J of 150°C can affect reliability.
- (4) Maximum power dissipation is a function of T_{J(max)}, θ_{JC}, and T_A. The maximum allowable power dissipation at any allowable ambient temperature is $PD = (T_J(max) - T_A)/\theta_{JC}$. Operating at the absolute maximum T_J of 150°C can affect reliability.

Electrical Characteristics (TA=+25°C, unless otherwise specified)

Parameter	Test Figure	Test Conditions	ULN2003			Unit	
			MIN	TYP	MAX		
$V_{I(on)}$	On-state input voltage	Figure 6 $V_{CE} = 2\text{ V}$	$I_C = 200\text{ mA}$	--	--	2.4	V
			$I_C = 250\text{ mA}$	--	--	2.7	
			$I_C = 300\text{ mA}$	--	--	3	
$V_{CE(sat)}$	Collector-emitter saturation voltage	Figure 5	$I_I = 250\text{ }\mu\text{A}$, $I_C = 100\text{ mA}$	--	0.9	1.1	V
			$I_I = 350\text{ }\mu\text{A}$, $I_C = 200\text{ mA}$	--	1	1.3	
			$I_I = 500\text{ }\mu\text{A}$, $I_C = 350\text{ mA}$	--	1.2	1.6	
I_{CEX}	Collector cutoff current	Figure 1 $V_{CE} = 50\text{ V}$, $I_I = 0$	--	--	50	μA	
		Figure 2 $V_{CE} = 50\text{ V}$, $T_A = +105^\circ\text{C}$, $I_I = 0$	--	--	100		
V_F	Clamp forward voltage	Figure 8 $I_F = 350\text{ mA}$	--	1.7	2	V	
$I_{I(off)}$	Off-state input current	Figure 3 $V_{CE} = 50\text{ V}$, $I_C = 500\text{ }\mu\text{A}$	50	65	--	μA	
I_I	Input current	Figure 4 $V_I = 3.85\text{ V}$	--	0.93	1.35	mA	
I_R	Clamp reverse current	Figure 7 $V_R = 50\text{ V}$	--	--	50	μA	
			$T_A = 70^\circ\text{C}$	--	--		100
C_i	Input capacitance	$V_I = 0$, $f = 1\text{ MHz}$	--	15	25	pF	

Switching Characteristics (TA = +25°C, unless otherwise specified)

Parameter	Test Conditions	ULN2003			UNIT
		MIN	TYP	MAX	
t_{PLH}	Propagation delay time, low- to high-level output	See Figure 9	0.25	1	μs
t_{PHL}	Propagation delay time, high- to low-level output	See Figure 9	0.25	1	μs
V_{OH}	High-level output voltage after switching	$V_S = 50\text{ V}$, $I_O = 300\text{ mA}$, See Figure 9	$V_S - 20$		mV

Parameter Measurement Information

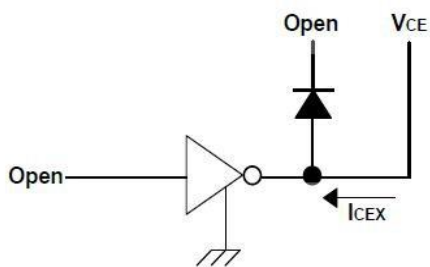

Fig.1 ICEX Test Circuit

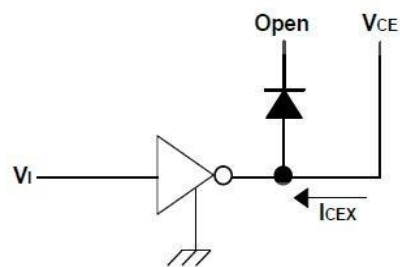

Fig.2 ICEX Test Circuit

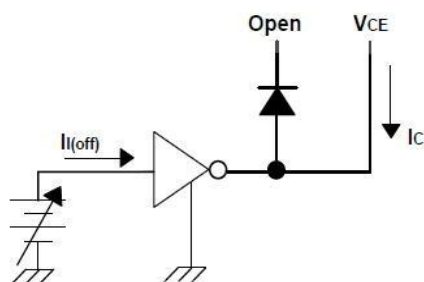

Fig.3 Ii(off) Test Circuit

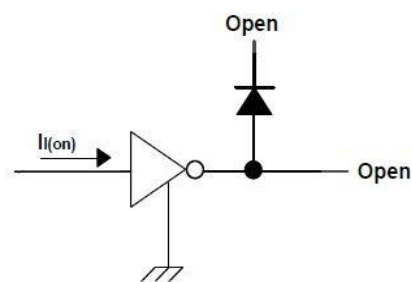

Fig.4 Ii Test Circuit

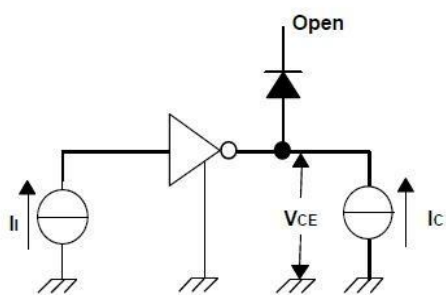

Fig. 5 hFE , VCE(sat) Test Circuit

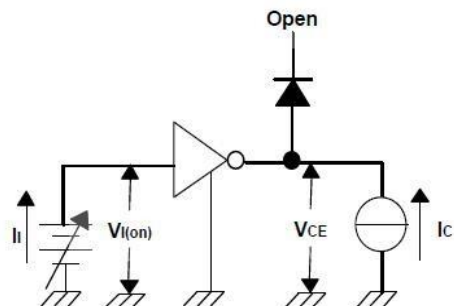

Fig. 6 Vi(on) Test Circuit

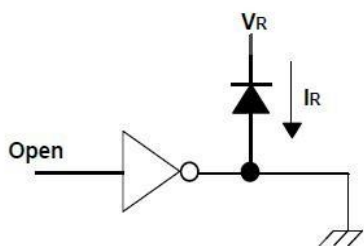

Fig. 7 IR Test Circuit

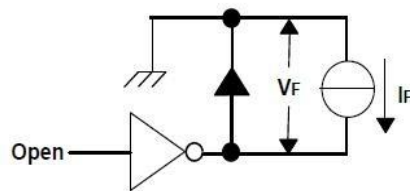

Fig. 8 VF Test Circuit

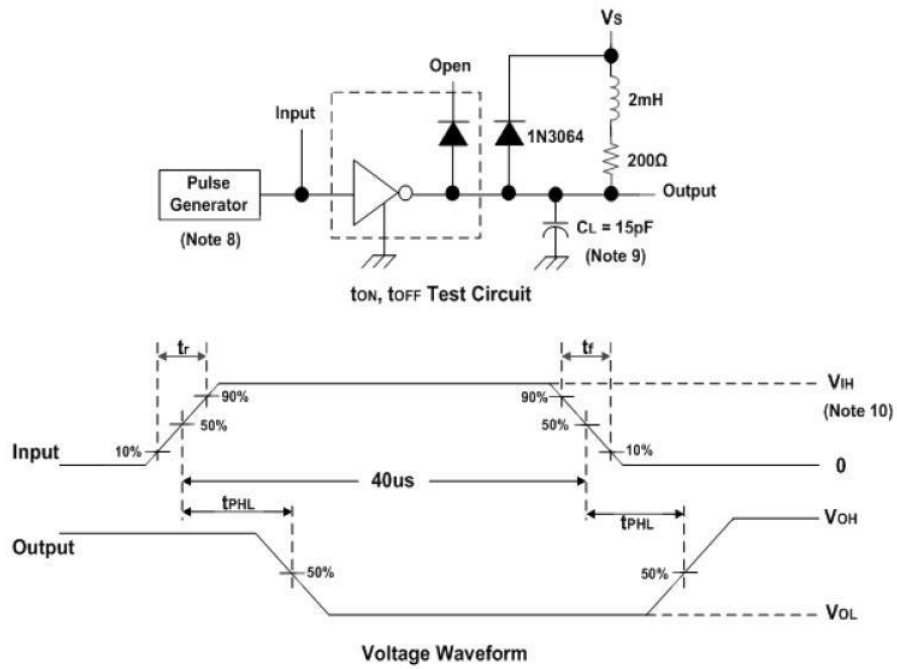

Fig. 9 Latch-Up Test Circuit and Voltage Waveform

Notes: 8. The pulse generator has the following characteristics:

Pulse Width=12.5Hz, output impedance 50Ω, $t_r \leq 5\text{ns}$, $t_f \leq 10\text{ns}$.

9. C_L includes probe and jig capacitance.

10. $V_{IH} = 3\text{V}$

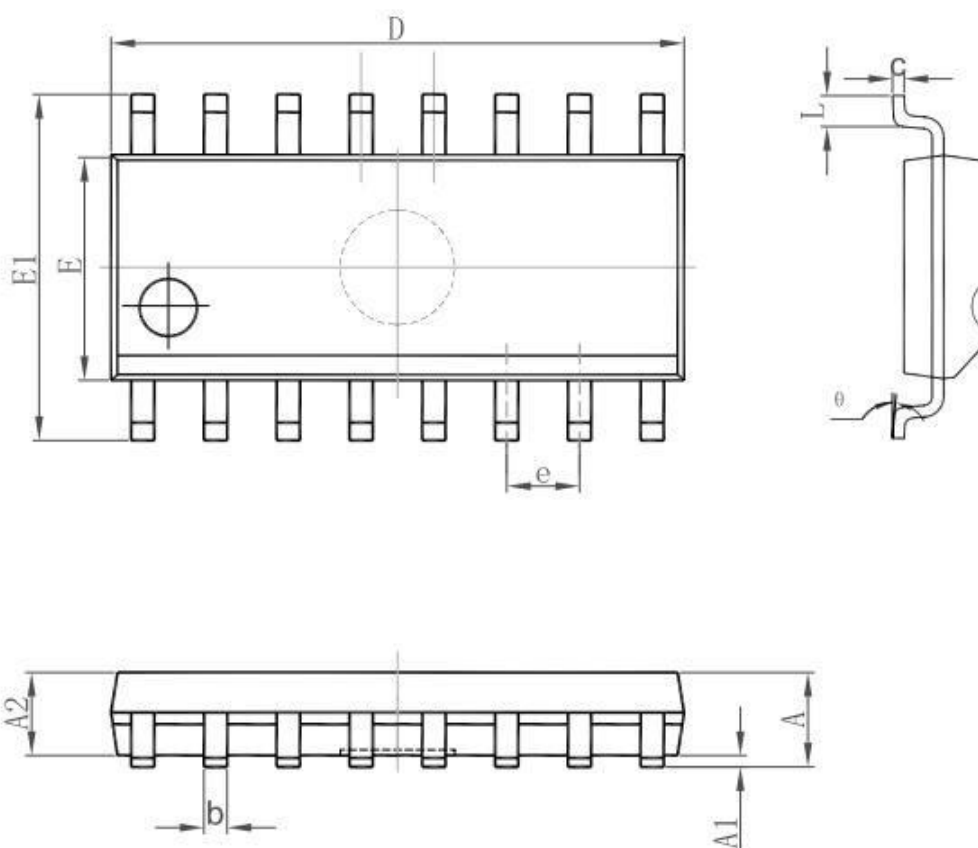
SOP16 Outline Dimensions

Symbol	Dimensions In Millimeters		Dimensions In Inches	
	Min	Max	Min	Max
A	1.350	1.750	0.053	0.069
A1	0.100	0.250	0.004	0.010
A2	1.350	1.550	0.053	0.061
b	0.330	0.510	0.013	0.020
c	0.170	0.250	0.007	0.010
D	9.800	10.200	0.386	0.402
E	3.800	4.000	0.150	0.157
E1	5.800	6.200	0.228	0.244
e	1.270 (BSC)		0.050 (BSC)	
L	0.400	1.270	0.016	0.050
θ	0°	8°	0°	8°

X-ON Electronics

Largest Supplier of Electrical and Electronic Components

Click to view similar products for [Darlington Transistors](#) category:

Click to view products by [Belling](#) manufacturer:

Other Similar products are found below :

[BDV64B](#) [SBSP52T1G](#) [Jantx2N6058](#) [LB1205-L-E](#) [2N6053](#) [MPSA63](#) [2N6667](#) [NTE256](#) [TIP120](#) [MJ11028](#) [TIP127](#) [Jantx2N6352](#) [2N6383](#)
[NJVBUB323ZT4G](#) [ULN2003](#) [ULN2803QN](#) [GN2003B](#) [MJD127T4G-JSM](#) [KID65004AF-EL/P](#) [ULN2803](#) [ULN2803CDWR](#) [HT62783ARTZ](#)
[2SB1560](#) [2SB852KT146B](#) [2SD2560](#) [TIP112TU](#) [BCV27](#) [MMBTA13-TP](#) [MMBTA14-TP](#) [MMSTA28T146](#) [BSP50H6327XTSA1](#) [NTE2557](#)
[NJVNJD35N04T4G](#) [MPSA29-D26Z](#) [MJD127T4](#) [FJB102TM](#) [FMMT38C](#) [BCV26E6327HTSA1](#) [BCV29](#) [BCV47](#) [FMMT734](#)
[BCV46E6327HTSA1](#) [BCV47E6327HTSA1](#) [BSP61H6327XTSA1](#) [BU941ZPFI](#) [FZT600](#) [FZT605](#) [FZT705](#) [2SB1316TL](#) [NTE245](#)