

Transient Voltage Suppressor

Features

- IEC 61000-4-2(ESD) $\pm 30KV$ (air), $\pm 30KV$ (contact)
- 350Watts peak pulse power ($t_p=8/20\mu s$)
- IEC61000-4-5(Lightning) $I_{ppMax}=25A@1.2/50-8/20\mu s$
- Ultra low capacitance: 1.5pF maximum
- Low clamping voltage
- Moisture sensitivity level: Level 1
- Weight 5.0mg
- Small package: SOD323

Exterior

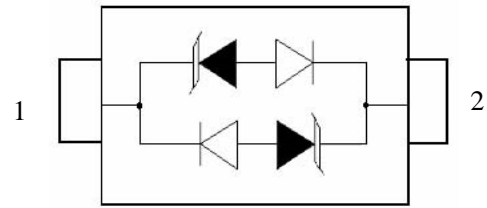

SOD323

Application Information

- Ethernet secondary side

Agency Approvals

Icon	Description
RoHS	Compliance with 2011/65/EU
HF	Compliance with IEC61249-2-21:2003
	Mean lead free

Part Number and Electrical Parameter

Part Number	$I_{DRM}@V_{DRM}$		$V_{BR}^{①}@I_R$			$V_C@I_{pp}^{②}$		$V_C@I_{pp}^{②}$		$V_C@I_{pp}^{②}$		$C_o^{③}$	
	μA	V	V	V	mA	V	A	V	A	V	A	TYP	MAX
	MAX		MIN	TYP		MAX		TYP		MAX			
BV03C-H	1	3.3	3.8	4	1	7	1	7	5	18.5	19	0.8	1.5

Absolute maximum ratings measured at $T=25^{\circ}C$ RH = 45%-75% (unless otherwise noted).

- ① V_{BR} is measured at $I_R=1mA$
- ② Surge Waveform: 8/20us.
- ③ Off-state capacitance is measured in $V_{DC}=0V, V_{RMS}=0.3V, f=1MHz$.

Part Numbering System

BV 03 C H
(1) (2) (3) (4)

- (1) Bencent Transient Voltage Suppressor
- (2) Stand-state Voltage : 3.3V
- (3) Bidirectional TVS
- (4) Bencent internal code

Mark



CC: Part Number

Transient Voltage Suppressor

V-I Curve

Parameters	Definition
V_C	Clamping voltage
I_{PP}	Surge waveform 8/20us
V_{DRM}	Stand-off Voltage
V_{BR}	Breakdown Voltage
I_{DRM}	Reverse Leakage Current
I_R	Test current
V_{SB}	Snapback voltage
I_{SB}	Test current
P_{pp}	Peak Pulse Power Dissipation

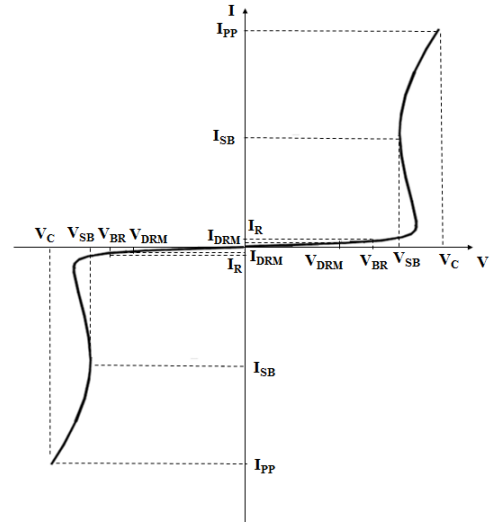

Typical Characteristics

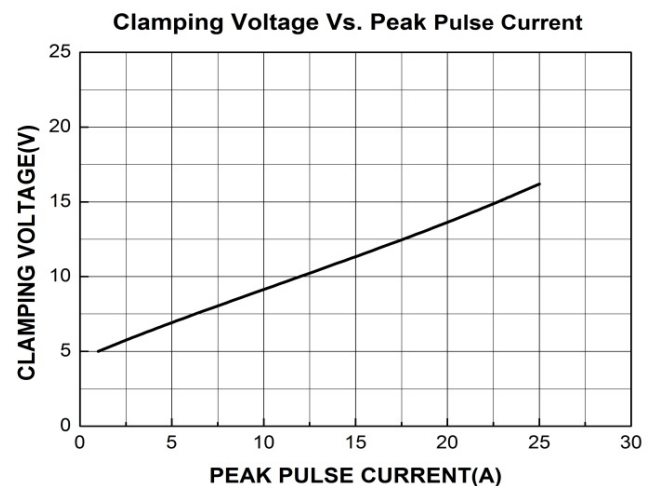
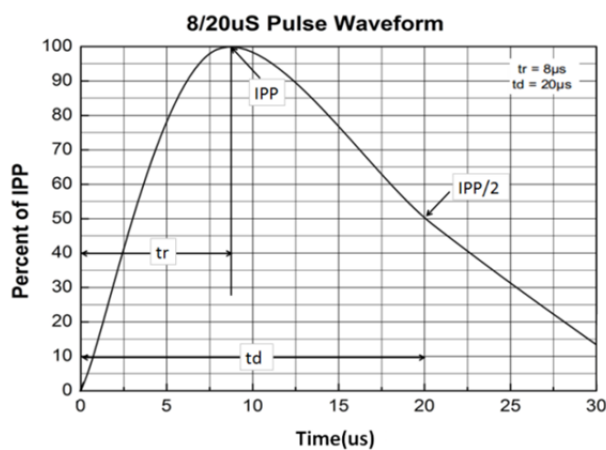
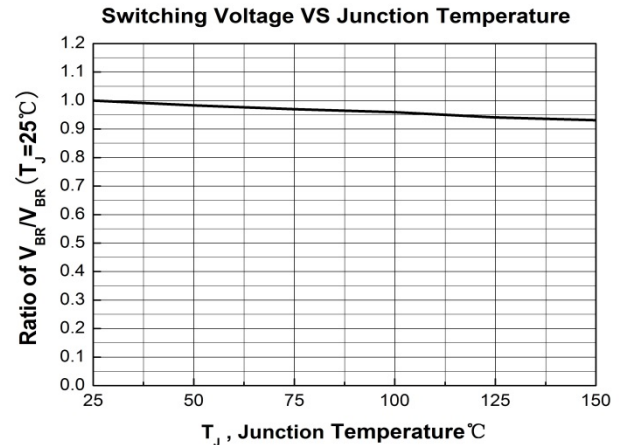
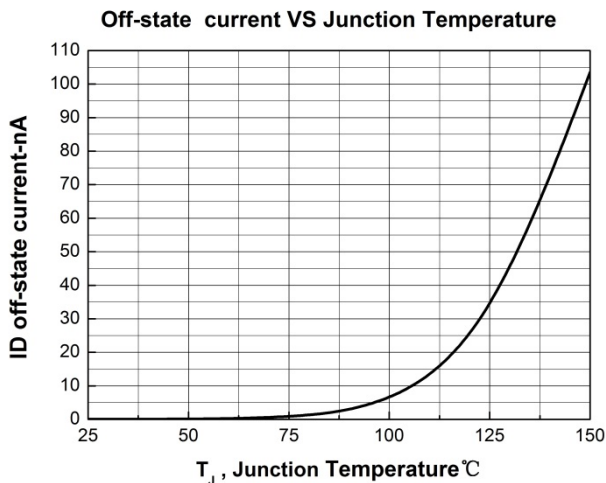

Thermal Considerations

symbol	Parameter	Value	Unit
T_J	Operating Junction Temperature Range	-55 to +150	°C
T_S	Storage Temperature Range	-55 to +150	°C

Transient Voltage Suppressor

Version: A2 2019-07-11

Environmental Characteristics

Testing items	Technical standards
High temperature Reverse Bias Test	Temperature: $150\pm 3^{\circ}\text{C}$ Bias= $80\%V_{\text{DRM}}$ Time:168H
High Temperature Life Test	Temperature: 150°C Time:168H
High-low Temperature Cycle test	Temperature: From -55°C to 150°C Dwell time : 30min,10~100cycles
High Temperature &High Humidity Test	Temperature: 85°C Humidity:85% Time:168H
Pressure cooker Test	Temperature: 121°C , 2atm. Humidity:100% Time:24H
Resistance of soldering heat	Temperature: $260\pm 5^{\circ}\text{C}$ Time of dip soldering: 10s, 3times

Note: The above testing items can be specified by customer's special request

Product Dimensions

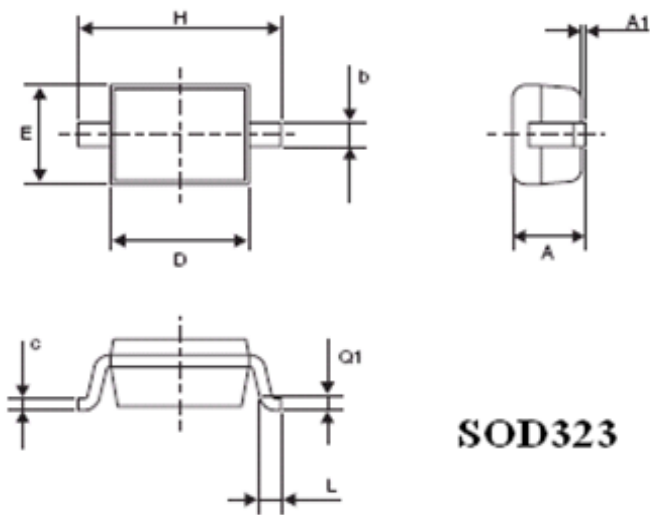

REF	mm	inch
A	1.17(max)	0.046(max)
A1	0.10(max)	0.004(max)
b	0.34 ± 0.10	0.013 ± 0.0039
c	0.17 ± 0.08	0.007 ± 0.0032
D	1.66 ± 0.14	0.065 ± 0.0055
E	1.28 ± 0.17	0.050 ± 0.0067
H	2.5 ± 0.2	0.098 ± 0.0079
L	0.28 ± 0.18	0.011 ± 0.0071
Q1	0.25 ± 0.15	0.010 ± 0.0059

Recommended Soldering Pad

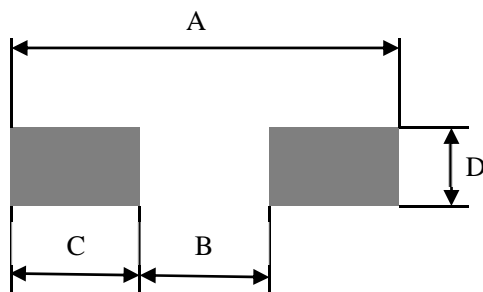

REF	mm	inch
A	3.20	0.126
B	1.08	0.043
C	1.06	0.042
D	0.54	0.021

Transient Voltage Suppressor

Reflow Profile

Reflow Condition		Pb-Free Assembly
Pre Heat	Temperature Min.	+150°C
	Temperature Max.	+200°C
	Time(Min to Max)	60 – 180 secs.
Average ramp up rate(Liquidus Temp(T_L) to peak)		3°C/sec. Max.
Ts(max) to T_L - Ramp-up Rate		3°C/sec. Max.
Reflow	- Temperature (T_L) (Liquidus)	+217°C
	- Temperature (T_L)	60 – 150 secs.
Peak Temp (T_P)		+(260+0/-5) °C
Time within 5°C of actual Peak Temp (T_P)		25 secs.
Ramp-down Rate		6°C/sec. Max.
Time 25°C to peak Temp (T_P)		8 min. Max.
Do not exceed		+260°C

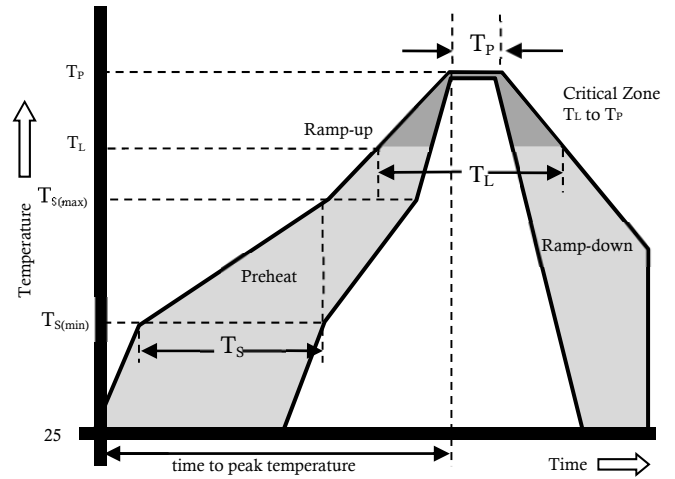

Package Reel Information

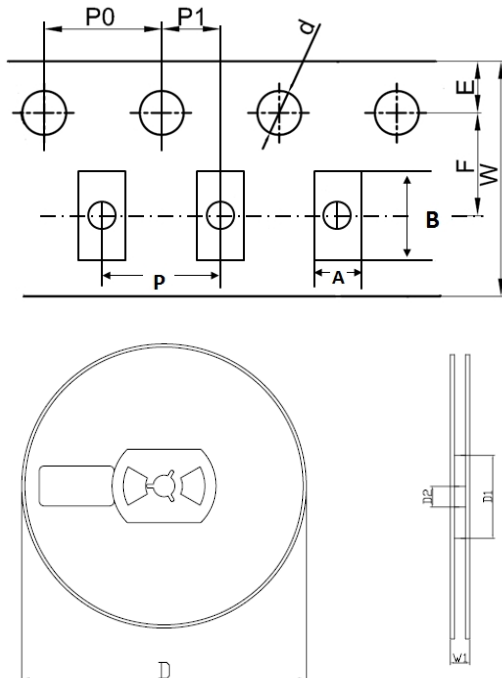

REF	mm	inch
A	1.46+/-0.1	0.057+/-0.004
B	3.10+/-0.3	0.122+/-0.012
d	1.50+/-0.1	0.059+/-0.004
D	178+/-1.0	7.008+/-0.039
D1	55+/-3	2.165+/-0.118
D2	13+/-0.5	0.512+/-0.020
E	1.75+/-0.1	0.069+/-0.004
F	3.5+/-0.2	0.138+/-0.008
P	4.0+/-0.2	0.157+/-0.008
P0	4.0+/-0.2	0.157+/-0.008
P1	2.0+/-0.2	0.079+/-0.008
W	8.0+/-0.2	0.315+/-0.008
W1	12.3+/-1.0	0.484+/-0.039

Outline	Reel (pcs)	Per Carton (pcs)	Reel Diameters (mm)	Carton Size(mm)		
				L	W	H
Taping	3,000	90,000	178	390	370	220

X-ON Electronics

Largest Supplier of Electrical and Electronic Components

Click to view similar products for [ESD Suppressors / TVS Diodes](#) category:

Click to view products by [Bencent](#) manufacturer:

Other Similar products are found below :

[60KS200C](#) [D18V0L1B2LP-7B](#) [D5V0F4U5P5-7](#) [DESD5V0U1BB-7](#) [NTE4902](#) [P4KE27CA](#) [P6KE11CA](#) [P6KE39CA-TP](#) [P6KE8.2A](#)
[SA110CA](#) [SA60CA](#) [SA64CA](#) [SMBJ12CATR](#) [SMBJ33CATR](#) [SMBJ8.0A](#) [ESD101-B1-02ELS E6327](#) [ESD105-B1-02EL E6327](#) [ESD112-B1-02EL E6327](#) [ESD119B1W01005E6327XTSA1](#) [ESD5V0L1B02VH6327XTSA1](#) [ESD7451N2T5G](#) [19180-510](#) [CPDT-5V0USP-HF](#)
[3.0SMCJ33CA-F](#) [3.0SMCJ36A-F](#) [HSPC16701B02TP](#) [D3V3Q1B2DLP3-7](#) [D55V0M1B2WS-7](#) [DESD5V0U1BL-7B](#) [DRTR5V0U4SL-7](#)
[SCM1293A-04SO](#) [ESD200-B1-CSP0201 E6327](#) [SM12-7](#) [SMF8.0A-TP](#) [SMLJ45CA-TP](#) [SMQA1000T1G](#) [CEN955 W/DATA](#) [82350120560](#)
[VESD12A1A-HD1-GS08](#) [CPDUR5V0R-HF](#) [CPDQC5V0U-HF](#) [CPDQC5V0USP-HF](#) [CPDQC5V0-HF](#) [IP4042CX5/LF,135](#) [D1213A-01LP4-7B](#) [D1213A-02WL-7](#) [1SMB33CAT3G-XYZ](#) [MMAD1108/TR13](#) [5KP100A](#) [5KP15A](#)