

➤ Features

- Size 0.06*0.03 inch /1.5*0.8 mm
- RoHS compliant, lead-free and halogen-free
- Fast response to fault current
- Low resistance
- Low profile
- Compatible with high temperature solders

➤ Applications

- Computer, Mobile phones, Multimedia
- Automotive, Industrial controls, Telephony and broadband
- Game machines, Portable electronics, Battery

➤ Electrical Characteristics (25°C)

Part Number	I_{hold}	I_{trip}	V_{max}	I_{max}	P_d typ	Time to trip		R_{min}	R_{1max}
	(A)	(A)	(V _{dc})	(A)	(W)	(A)	(Sec)	(Ω)	(Ω)
BSMD0603-001-60V	0.01	0.05	60	20	0.5	0.20	1.00	15.00	100.0
BSMD0603-002-60V	0.02	0.06	60	20	0.5	0.20	1.00	12.00	70.0
BSMD0603-003-30V	0.03	0.09	30	20	0.5	0.20	1.00	6.00	50.0
BSMD0603-004-24V	0.04	0.12	24	20	0.5	0.20	1.00	4.00	40.0
BSMD0603-005-15V	0.05	0.15	15	40	0.5	0.25	1.00	3.80	30.0
BSMD0603-005-24V	0.05	0.15	24	40	0.5	0.25	1.00	3.80	30.0
BSMD0603-005-33V	0.05	0.15	33	40	0.5	0.25	1.00	3.80	30.0
BSMD0603-010-15V	0.10	0.30	15	40	0.5	0.50	0.60	0.90	8.00
BSMD0603-010-24V	0.10	0.30	24	40	0.5	0.50	0.60	0.90	8.00
BSMD0603-010-33V	0.10	0.30	33	40	0.5	0.50	0.60	0.90	8.00
BSMD0603-020-9V	0.20	0.50	9	40	0.5	1.00	0.60	0.55	3.50
BSMD0603-020-12V	0.20	0.50	12	40	0.5	1.00	0.60	0.55	3.50
BSMD0603-020-16V	0.20	0.50	16	40	0.5	1.00	0.60	0.55	3.50
BSMD0603-020-24V	0.20	0.50	24	40	0.5	1.00	0.60	0.55	3.50
BSMD0603-025-9V	0.25	0.55	9	40	0.5	8.00	0.08	0.50	3.00
BSMD0603-025-12V	0.25	0.55	12	40	0.5	8.00	0.08	0.50	3.00
BSMD0603-025-16V	0.25	0.55	16	40	0.5	8.00	0.08	0.50	3.00
BSMD0603-025-24V	0.25	0.55	24	40	0.5	8.00	0.08	0.50	3.00
BSMD0603-035-6V	0.35	0.75	6	40	0.5	8.00	0.10	0.20	1.40
BSMD0603-035-12V	0.35	0.75	12	40	0.5	8.00	0.10	0.20	1.40

Part Number	I_{hold}	I_{trip}	V_{max}	I_{max}	$P_{d\ typ}$	Time to trip		R_{min}	R_{1max}
	(A)	(A)	(V _{dc})	(A)	(W)	(A)	(Sec)	(Ω)	(Ω)
BSMD0603-035-16V	0.35	0.75	16	40	0.5	8.00	0.10	0.20	1.40
BSMD0603-050-6V	0.50	1.00	6	40	0.5	8.00	0.10	0.10	0.80
BSMD0603-050-9V	0.50	1.00	9	40	0.5	8.00	0.10	0.10	0.80
BSMD0603-050-12V	0.50	1.00	12	40	0.5	8.00	0.10	0.10	0.80
BSMD0603-075-6V	0.75	1.50	6	40	0.5	8.00	0.10	0.06	0.45
BSMD0603-075-8V	0.75	1.50	8	40	0.5	8.00	0.10	0.06	0.45
BSMD0603-100-6V	1.00	2.00	6	40	0.5	8.00	0.10	0.05	0.30

➤ Vocabulary

- I_{hold} = Hold current: maximum current device will pass without tripping in 25°C still air.
- I_{trip} = Trip current: minimum current at which the device will trip in 25°C still air.
- V_{max} = Maximum voltage device can withstand without damage at rated current (I_{max}).
- I_{max} = Maximum fault current device can withstand without damage at rated voltage (V_{max}).
- $P_{d\ typ.}$ = Typical power dissipated from device when in the tripped state at 25°C still air.
- R_{min} = Minimum resistance of device in initial (un-soldered) state.
- R_{1max} = Maximum resistance of device at 25°C measured one hour after tripping or reflow soldering of 260°C for 20 sec.

Caution: Operation beyond the specified ratings may result in damage and possible arcing and flame.

➤ Warning

- Users shall independently assess the suitability of these devices for each of their applications.
- Operation of these devices beyond the stated maximum ratings could result in damage to the devices and lead to electrical arcing and/or fire.
- These devices are intended to protect against the effects of temporary over-current or over-temperature conditions and are not intended to perform as protective devices where such conditions are expected to be repetitive or prolonged in duration.
- Exposure to silicon-based oils, solvents, electrolytes, acids, and similar materials can adversely affect the prolonged of these PPTC devices.
- These devices undergo thermal expansion under fault conditions, and thus shall be provided with adequate space and be protected against mechanical stresses.
- Circuits with inductance may generate a voltage ($L\ di/dt$) above the rated voltage of the PPTC device.

➤ **Thermal Derating Curve**

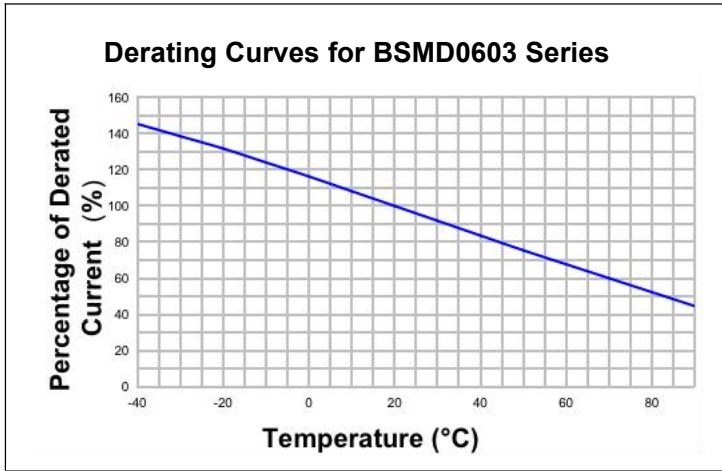

➤ **Average Time-Current Curve**

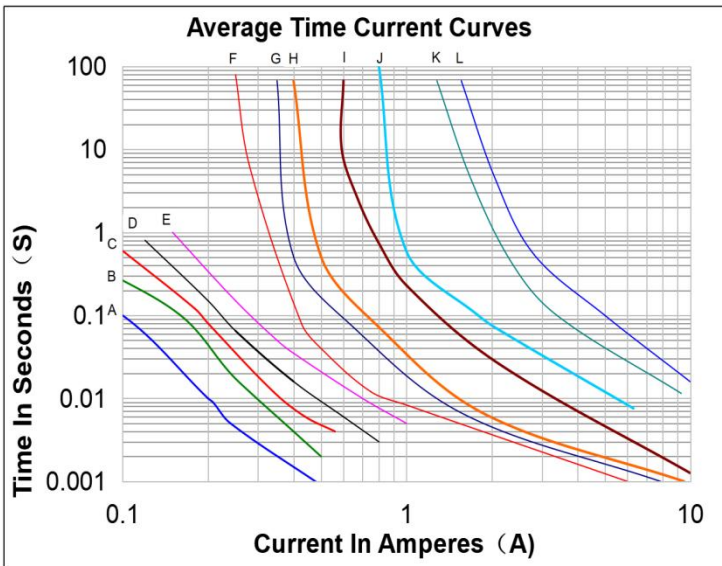

- A=BSMD0603-001
- B=BSMD0603-002
- C=BSMD0603-003
- D=BSMD0603-004
- E=BSMD0603-005
- F=BSMD0603-010
- G=BSMD0603-020
- H=BSMD0603-025
- I=BSMD0603-035
- J=BSMD0603-050
- K=BSMD0603-075
- L=BSMD0603-100

➤ Thermal Derating Chart

Part Number	Ambient operating temperature hold current(I_{hold})								
	-40°C	-20°C	0°C	25°C	40°C	50°C	60°C	70°C	85°C
BSMD0603-001	0.016	0.014	0.012	0.010	0.008	0.007	0.006	0.005	0.0035
BSMD0603-002	0.031	0.027	0.024	0.020	0.016	0.014	0.012	0.011	0.007
BSMD0603-003	0.048	0.041	0.036	0.030	0.024	0.021	0.018	0.016	0.011
BSMD0603-004	0.052	0.048	0.044	0.040	0.032	0.028	0.024	0.020	0.012
BSMD0603-005	0.065	0.060	0.055	0.050	0.040	0.035	0.031	0.025	0.015
BSMD0603-010	0.13	0.12	0.11	0.10	0.08	0.07	0.06	0.05	0.03
BSMD0603-020	0.27	0.25	0.23	0.20	0.17	0.14	0.12	0.10	0.07
BSMD0603-025	0.32	0.29	0.27	0.25	0.21	0.18	0.16	0.14	0.10
BSMD0603-035	0.47	0.41	0.38	0.35	0.29	0.26	0.24	0.20	0.14
BSMD0603-050	0.67	0.59	0.51	0.50	0.41	0.37	0.34	0.29	0.20
BSMD0603-075	0.98	0.85	0.81	0.75	0.60	0.54	0.44	0.40	0.31
BSMD0603-100	1.19	1.13	1.08	1.00	0.80	0.72	0.59	0.54	0.43

➤ Environmental Specifications

Test	Conditions	Resistance change
Passive aging	+85°C, 1000 hours	±5% typical
Humidity aging	+85°C, 85% R.H. , 168 hours	±5% typical
Thermal shock	+85°C to -40°C, 20 times	±33% typical
Resistance to solvent	MIL-STD-202,Method 215	No change
Vibration	MIL-STD-202,Method 201	No change
Ambient operating conditions : - 40 °C to +85 °C		
Maximum surface temperature of the device in the tripped state is 125 °C		

➤ **Soldering Parameters**

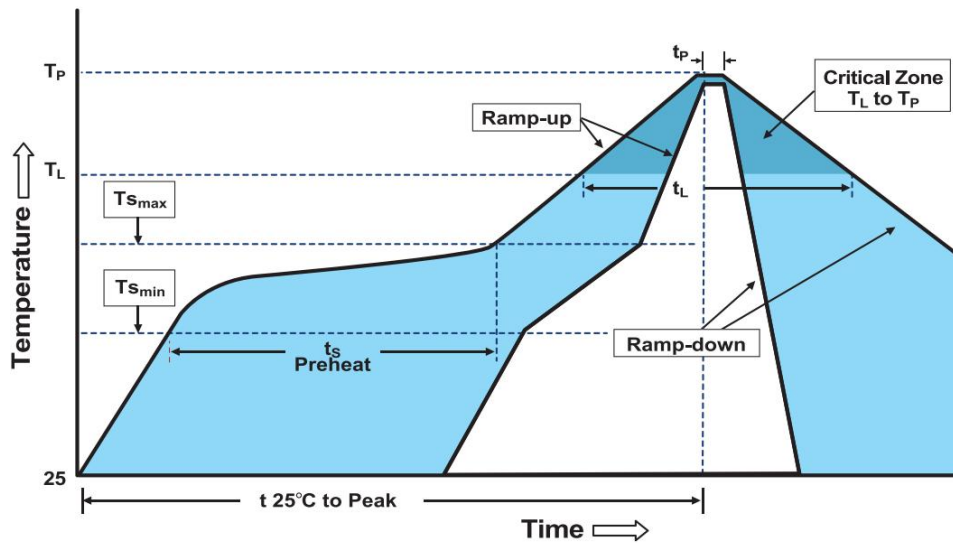

Profile Feature	Pb-Free Assembly
Average Ramp-Up Rate($T_{s_{max}}$ to T_p)	3°C/second max
Preheat -Temperature Min($T_{s_{min}}$) -Temperature Max($T_{s_{max}}$) -Time($T_{s_{min}}$ to $T_{s_{max}}$)	150°C 200°C 60~180 seconds
Time maintained above: -Temperature(T_L) -Time(t_L)	217°C 60~150 seconds
Peak Temperature(T_p)	260°C
Ramp-Down Rate	6°C/second max
Time 25°C to Peak Temperature	8 minutes max
Storage Condition	0°C~30°C,30%-60%RH

- Recommended reflow methods: IR, vapor phase oven, hot air oven, N₂ environment for lead-free.
- Recommended maximum paste thickness is 0.25mm.
- Devices can be cleaned using standard industry methods and solvents.

Note 1: All temperature refer to topside of the package, measured on the package body surface.

Note 2: If reflow temperatures exceed the recommended profile, devices may not meet the performance requirements.

➤ Physical Dimensions & Recommended Pad Layout (mm)

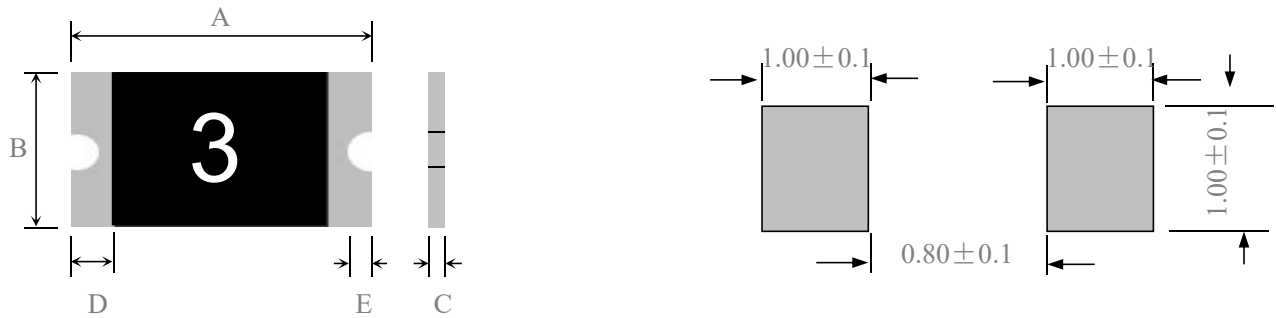

Part Number	Marking	Quantity	A		B		C		D	E
			Min	Max	Min	Max	Min	Max	Min	Min
BSMD0603-001-60V	X	4000	1.45	1.85	0.65	1.05	0.40	1.00	0.15	0.10
BSMD0603-002-60V	Y	4000	1.45	1.85	0.65	1.05	0.40	1.00	0.15	0.10
BSMD0603-003-30V	Z	4000	1.45	1.85	0.65	1.05	0.40	1.00	0.15	0.10
BSMD0603-004-24V	-	4000	1.45	1.85	0.65	1.05	0.40	1.00	0.15	0.10
BSMD0603-005-15V	-	4000	1.45	1.85	0.65	1.05	0.40	1.00	0.15	0.10
BSMD0603-005-24V	-	4000	1.45	1.85	0.65	1.05	0.40	1.00	0.15	0.10
BSMD0603-005-33V	-	4000	1.45	1.85	0.65	1.05	0.40	1.00	0.15	0.10
BSMD0603-010-15V	1	5000	1.45	1.85	0.65	1.05	0.40	1.00	0.15	0.10
BSMD0603-010-24V	1	5000	1.45	1.85	0.65	1.05	0.40	1.00	0.15	0.10
BSMD0603-010-33V	1	5000	1.45	1.85	0.65	1.05	0.40	1.00	0.15	0.10
BSMD0603-020-9V	2	5000	1.45	1.85	0.65	1.05	0.40	1.00	0.15	0.10
BSMD0603-020-12V	2	5000	1.45	1.85	0.65	1.05	0.40	1.00	0.15	0.10
BSMD0603-020-16V	2	5000	1.45	1.85	0.65	1.05	0.40	1.00	0.15	0.10
BSMD0603-020-24V	2	5000	1.45	1.85	0.65	1.05	0.40	1.00	0.15	0.10
BSMD0603-025-9V	2	5000	1.45	1.85	0.65	1.05	0.40	1.00	0.15	0.10
BSMD0603-025-12V	2	5000	1.45	1.85	0.65	1.05	0.40	1.00	0.15	0.10
BSMD0603-025-16V	2	5000	1.45	1.85	0.65	1.05	0.40	1.00	0.15	0.10
BSMD0603-025-24V	2	5000	1.45	1.85	0.65	1.05	0.40	1.00	0.15	0.10
BSMD0603-035-6V	3	5000	1.45	1.85	0.65	1.05	0.40	1.00	0.15	0.10
BSMD0603-035-12V	3	5000	1.45	1.85	0.65	1.05	0.40	1.00	0.15	0.10
BSMD0603-035-16V	3	5000	1.45	1.85	0.65	1.05	0.40	1.00	0.15	0.10
BSMD0603-050-6V	5	4000	1.45	1.85	0.65	1.05	0.55	1.15	0.15	0.10
BSMD0603-050-9V	5	4000	1.45	1.85	0.65	1.05	0.55	1.15	0.15	0.10
BSMD0603-050-12V	5	4000	1.45	1.85	0.65	1.05	0.55	1.15	0.15	0.10
BSMD0603-075-6V	7	4000	1.45	1.85	0.65	1.05	0.55	1.15	0.15	0.10
BSMD0603-075-8V	7	4000	1.45	1.85	0.65	1.05	0.55	1.15	0.15	0.10
BSMD0603-100-6V	0	4000	1.45	1.85	0.65	1.05	0.55	1.15	0.15	0.10

➤ **Tape And Reel Specifications (mm)**

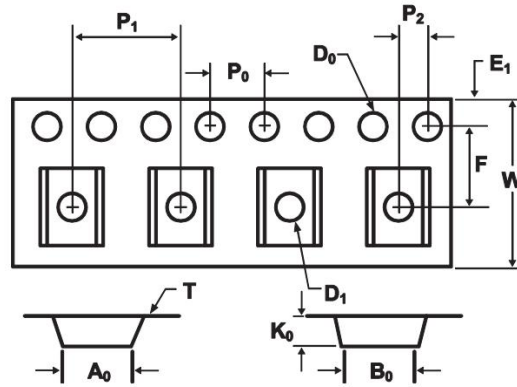

Governing Specifications	BSMD0603-001~ BSMD0603-025	BSMD0603-035~ BSMD0603-100
W	8.0 ± 0.3	8.0 ± 0.3
F	3.5 ± 0.05	3.5 ± 0.05
E ₁	1.75 ± 0.1	1.75 ± 0.1
D ₀	1.55 ± 0.05	1.55 ± 0.05
D ₁	1.0 ± 0.1	1.0 ± 0.1
P ₀	4.0 ± 0.1	4.0 ± 0.1
P ₁	4.0 ± 0.1	4.0 ± 0.1
P ₂	2.0 ± 0.05	2.0 ± 0.05
A ₀	1.10 ± 0.1	1.10 ± 0.1
B ₀	1.95 ± 0.1	1.95 ± 0.1
T	0.2 ± 0.1	0.2 ± 0.1
K ₀	0.72 ± 0.1	0.85 ± 0.1
Leader _{min}	390	390
Trailer _{min}	160	160

Reel Dimensions	
C	φ178 ± 1.0
D	φ60.2 ± 0.5
H	11.0 ± 0.5
W	9.0 ± 1.5

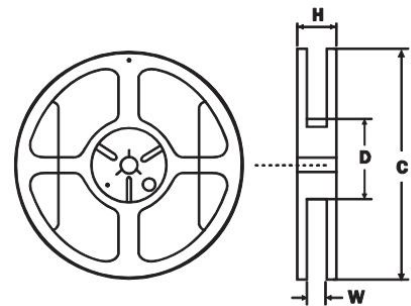

➤ **Contact information**

SHENZHEN BHFUSE INDUSTRIAL CO., LTD

TEL: 0755-85259917

E-MAIL: sales@bhfuse.com

X-ON Electronics

Largest Supplier of Electrical and Electronic Components

Click to view similar products for [Resettable Fuses - PPTC](#) category:

Click to view products by [BHFUSE](#) manufacturer:

Other Similar products are found below :

[RF0077-000](#) [RF0627-000](#) [RF3301-000](#) [RF3382-000](#) [SMD125-2](#) [RF1973-000](#) [RF2531-000](#) [RF2873-000](#) [RF3060-000](#) [TR600-150Q-B-0.5-0.130](#) [RXE090](#) [5E4795/04-1502](#) [TRF250-080T-B-1.0-0.125](#) [SMD100-2](#) [NIS5431MT1TXG](#) [SMD250-2](#) [RS30-090](#) [RS30-600](#) [RS30-800](#) [RS30-900](#) [RS60RB-160](#) [RS60SB-250](#) [SB250-145](#) [0ZCH0110AF2E](#) [0603L001/60YR](#) [0603L003/36YR](#) [BK250-120-SZ-E0.6](#) [BK60-010-DI-E0.5](#) [BK250-040-DY-E0.6](#) [RF2631-000](#) [NIS5420MT2TXG](#) [NIS5420MT3TXG](#) [NIS6420MT1TWG](#) [RF5032-000](#) [RF5051-000](#) [RF5034-000](#) [RF5105-000](#) [RF5062-000](#) [RF5055-000](#) [RF5052-000](#) [2920L075/72MR](#) [BSMD0603-025-24V](#) [BSMD0402L-005](#) [BSMD0603-010-9V](#) [BSMD1812-020-60V](#) [BSMD2920-400-30V](#) [BSMD0603-010-12V](#) [BSMD0805-035-30V](#) [BSMD1210-150-16V](#) [BSMD0805-003-60V](#)