

➤ Features

- Size 0.12*0.10 inch /3.2*2.5 mm
- RoHS compliant, lead-free and halogen-free
- Fast response to fault current
- Low resistance
- Low profile
- Compatible with high temperature solders

➤ Applications

- Computer, Mobile phones, Multimedia
- Automotive, Industrial controls, Telephony and broadband
- Game machines, Portable electronics, Battery

➤ Electrical Characteristics (25°C)

Part Number	I _{hold}	I _{trip}	V _{max}	I _{max}	P _{d typ}	Time to trip		R _{min}	R _{1max}
	(A)	(A)	(V _{dc})	(A)	(W)	(A)	(Sec)	(Ω)	(Ω)
BSMD1210-005-30V	0.05	0.15	30	40	0.6	0.25	1.50	2.800	50.00
BSMD1210-005-60V	0.05	0.15	60	40	0.6	0.25	1.50	2.800	50.00
BSMD1210-010-30V	0.10	0.30	30	40	0.6	0.50	0.60	0.800	15.00
BSMD1210-010-60V	0.10	0.30	60	40	0.6	0.50	0.60	0.800	15.00
BSMD1210-020-30V	0.20	0.40	30	40	0.6	8.00	0.02	0.400	5.000
BSMD1210-020-60V	0.20	0.40	60	40	0.6	8.00	0.02	0.400	5.000
BSMD1210-035-6V	0.35	0.75	6	100	0.6	8.00	0.20	0.200	1.300
BSMD1210-035-16V	0.35	0.75	16	100	0.6	8.00	0.20	0.200	1.300
BSMD1210-035-24V	0.35	0.75	24	40	0.6	8.00	0.20	0.200	1.300
BSMD1210-050-13.2V	0.50	1.00	13.2	100	0.6	8.00	0.10	0.180	0.900
BSMD1210-050-16V	0.50	1.00	16	100	0.6	8.00	0.10	0.180	0.900
BSMD1210-050-24V	0.50	1.00	24	100	0.6	8.00	0.10	0.180	0.900
BSMD1210-075-6V	0.75	1.50	6	100	0.6	8.00	0.10	0.070	0.400
BSMD1210-075-16V	0.75	1.50	16	100	0.6	8.00	0.10	0.070	0.400
BSMD1210-110-6V	1.10	2.20	6	100	0.6	8.00	0.30	0.050	0.210
BSMD1210-110-12V	1.10	2.20	12	100	0.6	8.00	0.30	0.050	0.210
BSMD1210-110-16V	1.10	2.20	16	100	0.6	8.00	0.30	0.050	0.210
BSMD1210-150-6V	1.50	3.00	6	100	0.8	8.00	0.50	0.030	0.110
BSMD1210-150-12V	1.50	3.00	12	100	0.8	8.00	0.50	0.030	0.110
BSMD1210-150-16V	1.50	3.00	16	100	0.8	8.00	0.50	0.030	0.110
BSMD1210-175-6V	1.75	3.50	6	100	0.8	8.00	0.60	0.020	0.080
BSMD1210-200-6V	2.00	4.00	6	100	0.8	8.00	1.00	0.015	0.070

➤ Vocabulary

- I_{hold}** = Hold current: maximum current device will pass without tripping in 25°C still air.
- I_{trip}** = Trip current: minimum current at which the device will trip in 25°C still air.
- V_{max}** = Maximum voltage device can withstand without damage at rated current (**I_{max}**).
- I_{max}** = Maximum fault current device can withstand without damage at rated voltage (**V_{max}**).
- P_{d typ.}** = Typical power dissipated from device when in the tripped state at 25°C still air.
- R_{min}** = Minimum resistance of device in initial (un-soldered) state.
- R_{1max}** = Maximum resistance of device at 25°C measured one hour after tripping or reflow soldering of 260°C for 20 sec.

Caution: Operation beyond the specified ratings may result in damage and possible arcing and flame.

➤ Warning

- Users shall independently assess the suitability of these devices for each of their applications.
- Operation of these devices beyond the stated maximum ratings could result in damage to the devices and lead to electrical arcing and/or fire.
- These devices are intended to protect against the effects of temporary over-current or over-temperature conditions and are not intended to perform as protective devices where such conditions are expected to be repetitive or prolonged in duration.
- Exposure to silicon-based oils, solvents, electrolytes, acids, and similar materials can adversely affect the prolonged of these PPTC devices.
- These devices undergo thermal expansion under fault conditions, and thus shall be provided with adequate space and be protected against mechanical stresses.
- Circuits with inductance may generate a voltage ($L di/dt$) above the rated voltage of the PPTC device.

➤ **Thermal Derating Curve**

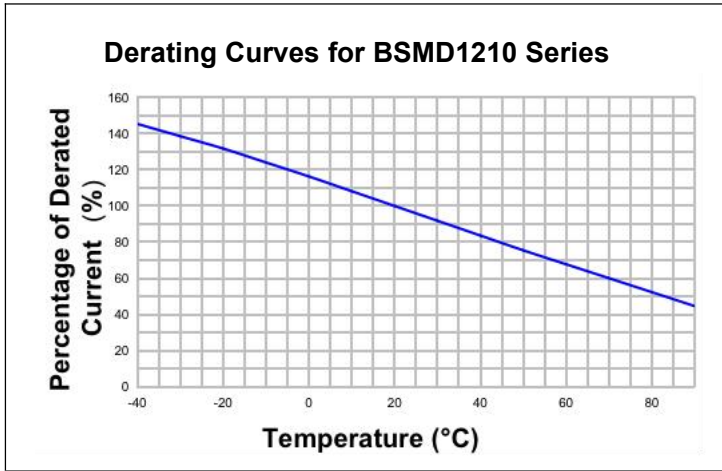

➤ **Average Time-Current Curve**

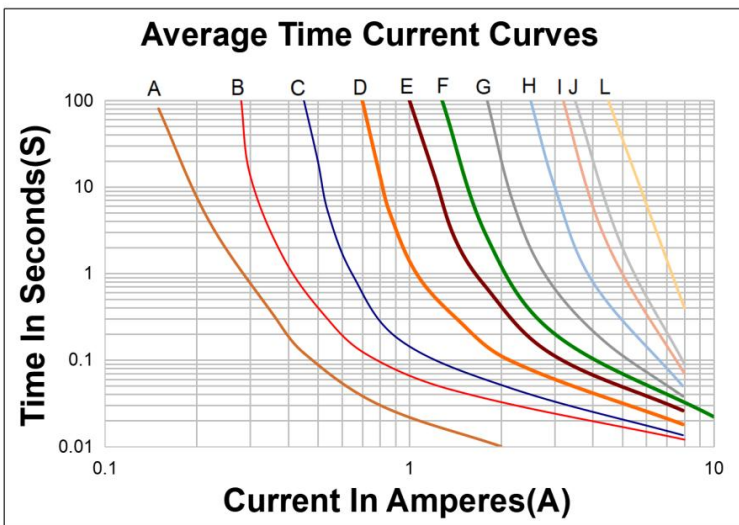

- A=BSMD1210-005
- B=BSMD1210-010
- C=BSMD1210-020
- D=BSMD1210-035
- E=BSMD1210-050
- F=BSMD1210-075
- G=BSMD1210-110
- H=BSMD1210-150
- I=BSMD1210-175
- J=BSMD1210-200

➤ Thermal Derating Chart

Part Number	Ambient operating temperature hold current(I_{hold})								
	-40°C	-20°C	0°C	25°C	40°C	50°C	60°C	70°C	85°C
BSMD1210-005	0.08	0.07	0.06	0.05	0.04	0.04	0.03	0.03	0.02
BSMD1210-010	0.16	0.14	0.12	0.10	0.08	0.07	0.06	0.05	0.03
BSMD1210-020	0.29	0.26	0.22	0.20	0.16	0.14	0.13	0.11	0.08
BSMD1210-035	0.47	0.45	0.40	0.35	0.33	0.28	0.24	0.21	0.18
BSMD1210-050	0.76	0.67	0.58	0.50	0.43	0.40	0.36	0.32	0.28
BSMD1210-075	1.00	0.97	0.86	0.75	0.64	0.59	0.54	0.48	0.40
BSMD1210-110	1.69	1.48	1.29	1.10	0.88	0.76	0.65	0.57	0.43
BSMD1210-150	2.13	1.92	1.71	1.50	1.26	1.14	1.01	0.89	0.71
BSMD1210-175	2.54	2.30	2.02	1.75	1.47	1.33	1.18	1.05	0.86
BSMD1210-200	2.90	2.63	2.31	2.00	1.68	1.52	1.35	1.20	0.98

➤ Environmental Specifications

Test	Conditions	Resistance change
Passive aging	+85°C, 1000 hours	±5% typical
Humidity aging	+85°C, 85% R.H. , 168 hours	±5% typical
Thermal shock	+85°C to -40°C, 20 times	±33% typical
Resistance to solvent	MIL-STD-202,Method 215	No change
Vibration	MIL-STD-202,Method 201	No change
Ambient operating conditions : - 40 °C to +85 °C		
Maximum surface temperature of the device in the tripped state is 125 °C		

➤ **Soldering Parameters**

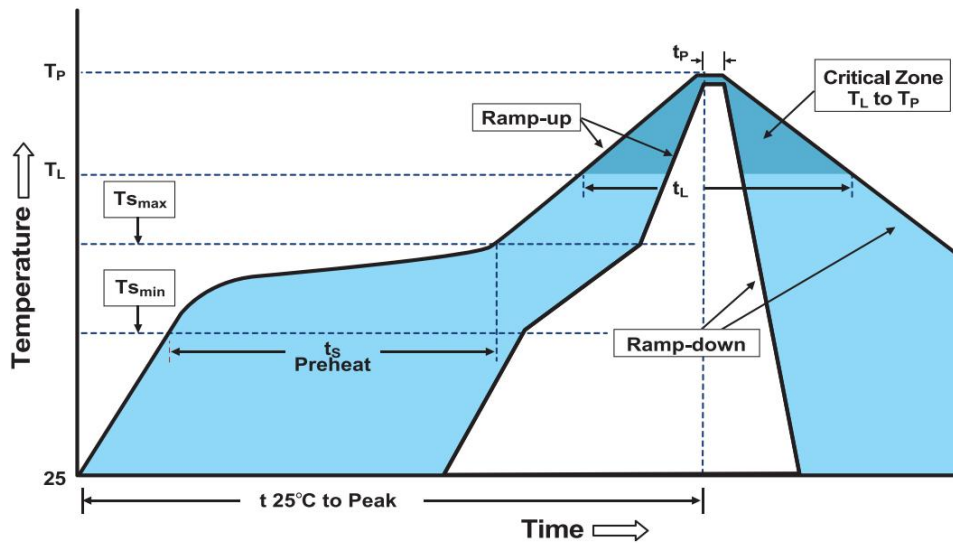

Profile Feature	Pb-Free Assembly
Average Ramp-Up Rate($T_{s_{max}}$ to T_p)	3°C/second max
Preheat -Temperature Min($T_{s_{min}}$) -Temperature Max($T_{s_{max}}$) -Time($T_{s_{min}}$ to $T_{s_{max}}$)	150°C 200°C 60~180 seconds
Time maintained above: -Temperature(T_L) -Time(t_L)	217°C 60~150 seconds
Peak Temperature(T_p)	260°C
Ramp-Down Rate	6°C/second max
Time 25°C to Peak Temperature	8 minutes max
Storage Condition	0°C~30°C,30%-60%RH

- Recommended reflow methods: IR, vapor phase oven, hot air oven, N₂ environment for lead-free.
- Recommended maximum paste thickness is 0.25mm.
- Devices can be cleaned using standard industry methods and solvents.

Note 1: All temperature refer to topside of the package, measured on the package body surface.

Note 2: If reflow temperatures exceed the recommended profile, devices may not meet the performance requirements.

➤ **Physical Dimensions & Recommended Pad Layout (mm)**

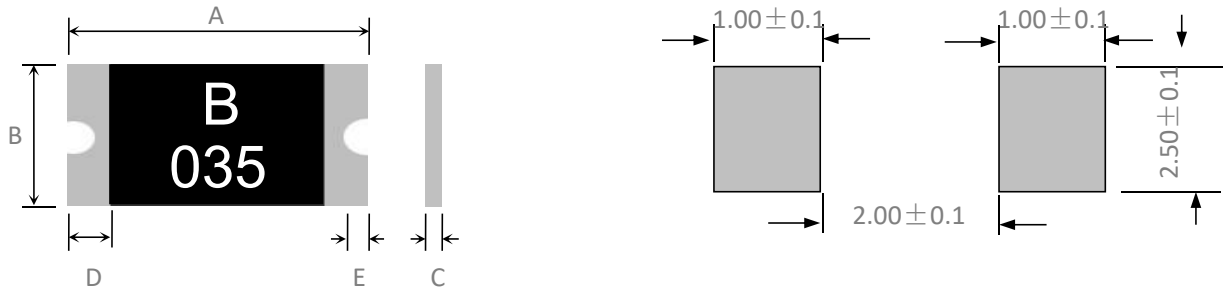

Part Number	Marking	Quantity	A		B		C		D	E
			Min	Max	Min	Max	Min	Max	Min	Min
BSMD1210-005-30V	B005	4000	3.00	3.50	2.35	2.80	0.60	1.20	0.30	0.10
BSMD1210-005-60V	B005	4000	3.00	3.50	2.35	2.80	0.60	1.20	0.30	0.10
BSMD1210-010-30V	B010	4000	3.00	3.50	2.35	2.80	0.60	1.20	0.30	0.10
BSMD1210-010-60V	B010	4000	3.00	3.50	2.35	2.80	0.60	1.20	0.30	0.10
BSMD1210-020-30V	B020	4000	3.00	3.50	2.35	2.80	0.50	1.10	0.30	0.10
BSMD1210-020-60V	B020	4000	3.00	3.50	2.35	2.80	0.50	1.10	0.30	0.10
BSMD1210-035-6V	B035	4000	3.00	3.50	2.35	2.80	0.50	1.10	0.30	0.10
BSMD1210-035-16V	B035	4000	3.00	3.50	2.35	2.80	0.50	1.10	0.30	0.10
BSMD1210-035-24V	B035	4000	3.00	3.50	2.35	2.80	0.50	1.10	0.30	0.10
BSMD1210-050-13.2V	B050	4000	3.00	3.50	2.35	2.80	0.50	1.10	0.30	0.10
BSMD1210-050-16V	B050	4000	3.00	3.50	2.35	2.80	0.50	1.10	0.30	0.10
BSMD1210-050-24V	B050	4000	3.00	3.50	2.35	2.80	0.50	1.10	0.30	0.10
BSMD1210-075-6V	B075	4000	3.00	3.50	2.35	2.80	0.50	1.10	0.30	0.10
BSMD1210-075-16V	B075	4000	3.00	3.50	2.35	2.80	0.50	1.10	0.30	0.10
BSMD1210-110-6V	B110	4000	3.00	3.50	2.35	2.80	0.50	1.10	0.30	0.10
BSMD1210-110-12V	B110	4000	3.00	3.50	2.35	2.80	0.50	1.10	0.30	0.10
BSMD1210-110-16V	B110	4000	3.00	3.50	2.35	2.80	0.50	1.10	0.30	0.10
BSMD1210-150-6V	B150	4000	3.00	3.50	2.35	2.80	0.50	1.20	0.30	0.10
BSMD1210-150-12V	B150	4000	3.00	3.50	2.35	2.80	0.50	1.20	0.30	0.10
BSMD1210-150-16V	B150	4000	3.00	3.50	2.35	2.80	0.50	1.20	0.30	0.10
BSMD1210-175-6V	B175	4000	3.00	3.50	2.35	2.80	0.80	1.40	0.30	0.10
BSMD1210-200-6V	B200	4000	3.00	3.50	2.35	2.80	0.80	1.40	0.30	0.10

➤ **Tape And Reel Specifications (mm)**

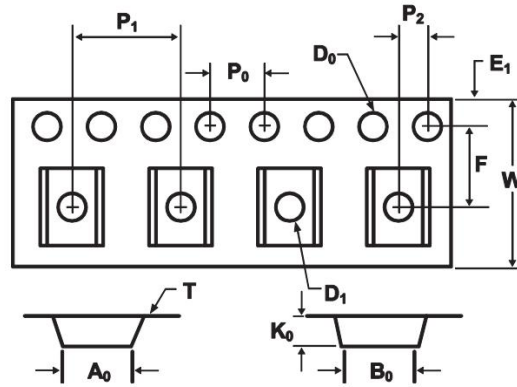

Governing Specifications	BSMD1210-005~ BSMD1210-035	BSMD1210-050~ BSMD1210-175	BSMD1210-200
W	8.15 ± 0.2	8.15 ± 0.2	8.15 ± 0.2
F	3.5 ± 0.05	3.5 ± 0.05	3.5 ± 0.05
E ₁	1.75 ± 0.1	1.75 ± 0.1	1.75 ± 0.1
D ₀	1.50 + 0.1, -0	1.50 + 0.1, -0	1.50 + 0.1, -0
D ₁	1.0 ± 0.1	1.0 ± 0.1	1.0 ± 0.1
P ₀	4.0 ± 0.1	4.0 ± 0.1	4.0 ± 0.1
P ₁	4.0 ± 0.1	4.0 ± 0.1	4.0 ± 0.1
P ₂	2.0 ± 0.05	2.0 ± 0.05	2.0 ± 0.05
A ₀	2.82 ± 0.1	2.82 ± 0.1	2.82 ± 0.1
B ₀	3.52 ± 0.1	3.52 ± 0.1	3.52 ± 0.1
T	0.6	0.6	0.6
K ₀	1.04 ± 0.1	1.04 ± 0.1	1.04 ± 0.1
Leader _{min}	390	390	390
Trailer _{min}	160	160	160

Reel Dimensions	
C	φ178 ± 1.0
D	φ60 ± 0.5
H	12.6 ± 0.5
W	9.0 ± 0.5

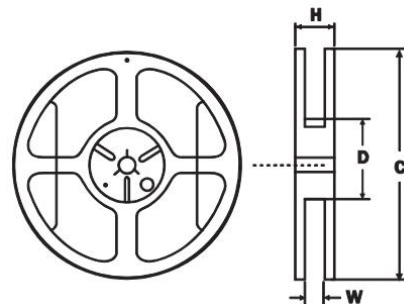

➤ **Contact information**

SHENZHEN BHFUSE INDUSTRIAL CO., LTD

TEL: 0755-85259917

E-MAIL: sales@bhfuse.com

X-ON Electronics

Largest Supplier of Electrical and Electronic Components

Click to view similar products for [Resettable Fuses - PPTC](#) category:

Click to view products by [BHFUSE](#) manufacturer:

Other Similar products are found below :

[RF0077-000](#) [RF0627-000](#) [RF3301-000](#) [RF3382-000](#) [SMD125-2](#) [RF1973-000](#) [RF2531-000](#) [RF2873-000](#) [RF3060-000](#) [TR600-150Q-B-0.5-0.130](#) [RXE090](#) [5E4795/04-1502](#) [TRF250-080T-B-1.0-0.125](#) [SMD100-2](#) [NIS5431MT1TXG](#) [SMD250-2](#) [RS30-090](#) [RS30-600](#) [RS30-800](#) [RS30-900](#) [RS60RB-160](#) [RS60SB-250](#) [SB250-145](#) [0ZCH0110AF2E](#) [0603L001/60YR](#) [0603L003/36YR](#) [BK250-120-SZ-E0.6](#) [BK60-010-DI-E0.5](#) [BK250-040-DY-E0.6](#) [RF2631-000](#) [NIS5420MT2TXG](#) [NIS5420MT3TXG](#) [NIS6420MT1TWG](#) [RF5032-000](#) [RF5051-000](#) [RF5034-000](#) [RF5105-000](#) [RF5062-000](#) [RF5055-000](#) [RF5052-000](#) [2920L075/72MR](#) [BSMD0603-025-24V](#) [BSMD0402L-005](#) [BSMD0603-010-9V](#) [BSMD1812-020-60V](#) [BSMD2920-400-30V](#) [BSMD0603-010-12V](#) [BSMD0805-035-30V](#) [BSMD1210-150-16V](#) [BSMD0805-003-60V](#)