

➤ Features

- Size 0.34*0.25 inch
- RoHS compliant, lead-free and halogen-free
- Fast response to fault current
- Low profile
- High voltage
- Compatible with high temperature solders

➤ Applications

- Computer, Mobile phones, Multimedia
- Automotive, Industrial controls, Telephony and broadband
- Game machines, Portable electronics, Battery

➤ Electrical Characteristics (25°C)

Part Number	I_{hold}	I_{trip}	V_{max}	I_{max}	$P_d\ typ$	Time to trip		R_{min}	$R1_{max}$
	(A)	(A)	(V _{dc})	(A)	(W)	(A)	(Sec)	(Ω)	(Ω)
BSMD3425-200-60V	2.00	4.00	60	20	2.5	8.00	10.0	0.040	0.200
BSMD3425-260-60V	2.60	5.20	60	20	2.5	8.00	10.0	0.020	0.120
BSMD3425-300-36V	3.00	6.00	36	20	2.5	8.00	20.0	0.010	0.060

➤ Vocabulary

- I_{hold}** = Hold current: maximum current device will pass without tripping in 25°C still air.
- I_{trip}** = Trip current: minimum current at which the device will trip in 25°C still air.
- V_{max}** = Maximum voltage device can withstand without damage at rated current (**I_{max}**).
- I_{max}** = Maximum fault current device can withstand without damage at rated voltage (**V_{max}**).
- P_{d typ.}** = Typical power dissipated from device when in the tripped state at 25°C still air.
- R_{min}** = Minimum resistance of device in initial (un-soldered) state.
- R_{1max}** = Maximum resistance of device at 25°C measured one hour after tripping or reflow soldering of 260°C for 20 sec.

Caution: Operation beyond the specified ratings may result in damage and possible arcing and flame.

➤ Warning

- Users shall independently assess the suitability of these devices for each of their applications.
- Operation of these devices beyond the stated maximum ratings could result in damage to the devices and lead to electrical arcing and/or fire.
- These devices are intended to protect against the effects of temporary over-current or over-temperature conditions and are not intended to perform as protective devices where such conditions are expected to be repetitive or prolonged in duration.
- Exposure to silicon-based oils, solvents, electrolytes, acids, and similar materials can adversely affect the prolonged of these PPTC devices.
- These devices undergo thermal expansion under fault conditions, and thus shall be provided with adequate space and be protected against mechanical stresses.
- Circuits with inductance may generate a voltage ($L di/dt$) above the rated voltage of the PPTC device.

➤ Thermal Derating Curve

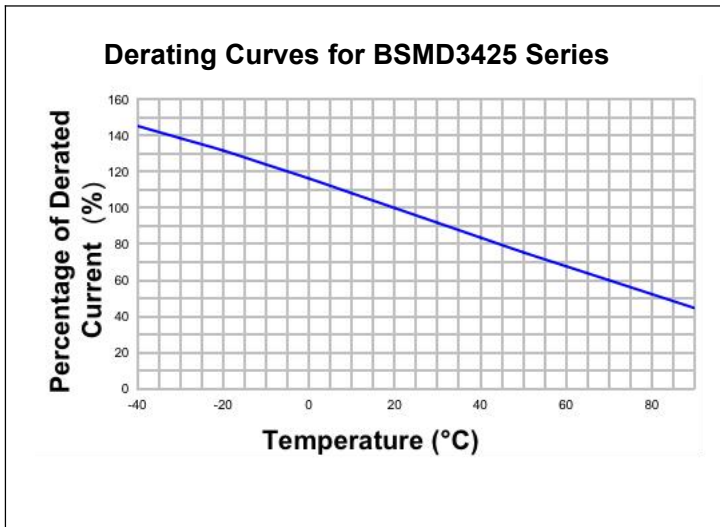

➤ Average Time-Current Curve

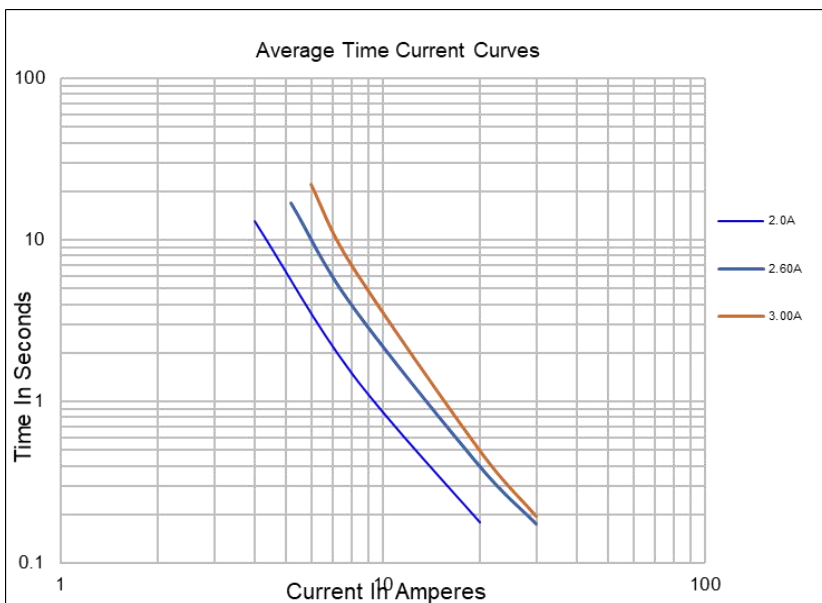

➤ Thermal Derating Chart

Part Number	Ambient operating temperature hold current(I_{hold})								
	-40°C	-20°C	0°C	25°C	40°C	50°C	60°C	70°C	85°C
BSMD3425-200-60V	3.07	2.73	2.39	2.00	1.71	1.54	1.37	1.20	0.95
BSMD3425-260-60V	4.01	3.56	3.12	2.60	2.22	2.00	1.77	1.55	1.21
BSMD3425-300-36V	4.43	3.98	3.52	3.00	2.61	2.39	2.16	1.93	1.59

➤ Environmental Specifications

Test	Conditions	Resistance change
Passive aging	+85°C, 1000 hours	±5% typical
Humidity aging	+85°C, 85% R.H. , 168 hours	±5% typical
Thermal shock	+85°C to -40°C, 20 times	±33% typical
Resistance to solvent	MIL-STD-202,Method 215	No change
Vibration	MIL-STD-202,Method 201	No change
Ambient operating conditions : - 40 °C to +85 °C		
Maximum surface temperature of the device in the tripped state is 125 °C		

➤ **Soldering Parameters**

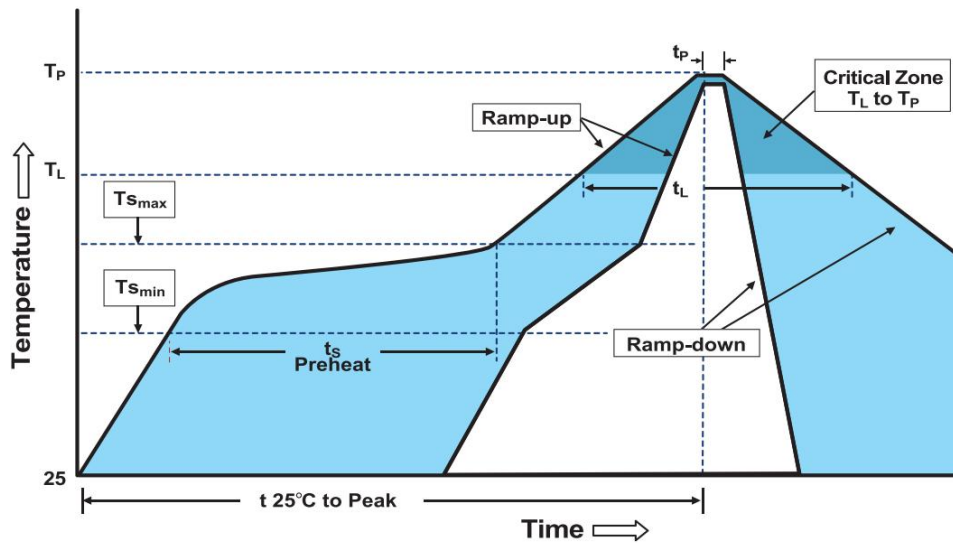

Profile Feature	Pb-Free Assembly
Average Ramp-Up Rate($T_{s_{max}}$ to T_P)	3°C/second max
Preheat -Temperature Min($T_{s_{min}}$) -Temperature Max($T_{s_{max}}$) -Time($T_{s_{min}}$ to $T_{s_{max}}$)	150°C 200°C 60~180 seconds
Time maintained above: -Temperature(T_L) -Time(t_L)	217°C 60~150 seconds
Peak Temperature(T_P)	260°C
Ramp-Down Rate	6°C/second max
Time 25°C to Peak Temperature	8 minutes max
Storage Condition	0°C~30°C,30%-60%RH

- Recommended reflow methods: IR, vapor phase oven, hot air oven, N₂ environment for lead-free.
- Recommended maximum paste thickness is 0.25mm.
- Devices can be cleaned using standard industry methods and solvents.

Note 1: All temperature refer to topside of the package, measured on the package body surface.

Note 2: If reflow temperatures exceed the recommended profile, devices may not meet the performance requirements.

➤ **Physical Dimensions & Recommended Pad Layout (mm)**

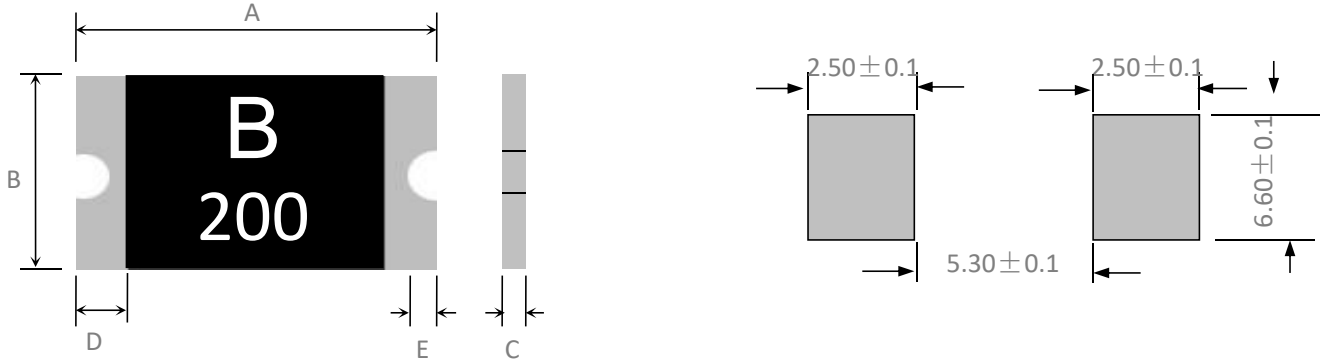

Part Number	Marking	Quantity	A		B		C		D	E
			Min	Max	Min	Max	Min	Max	Min	Min
BSMD3425-200-60V	B200	1500	8.30	9.00	6.00	6.70	1.00	2.00	0.30	0.25
BSMD3425-260-60V	B260	1500	8.30	9.00	6.00	6.70	1.00	2.00	0.30	0.25
BSMD3425-300-36V	B300	1500	8.30	9.00	6.00	6.70	1.00	2.00	0.30	0.25

➤ **Tape And Reel Specifications (mm)**

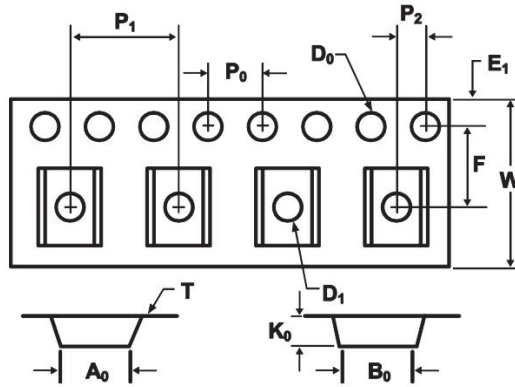

Governing Specifications	BSMD3425-200-60V BSMD3425-260-60V BSMD3425-300-36V
W	16.0 ± 0.3
F	7.5 ± 0.05
E ₁	1.75 ± 0.1
D ₀	1.50 ± 0.05
D ₁	1.55 _{min}
P ₀	4.0 ± 0.1
P ₁	8.0 ± 0.1
P ₂	2.0 ± 0.05
A ₀	7.0 ± 0.1
B ₀	9.5 ± 0.1
T	0.6
K ₀	2.2
Leader _{min}	390
Trailer _{min}	160

Reel Dimensions	
C	φ180 ± 3.0
D	φ60.2 ± 0.5
H	22.4 ± 1.0
W	16.4 ± 0.2

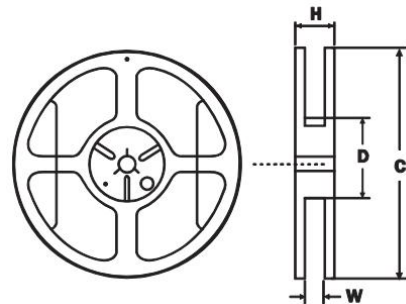

➤ **Contact information**

SHENZHEN BHFUSE INDUSTRIAL CO., LTD

TEL: 0755-85259917

E-MAIL: sales@bhfuse.com

X-ON Electronics

Largest Supplier of Electrical and Electronic Components

Click to view similar products for [Resettable Fuses - PPTC](#) category:

Click to view products by [BHFUSE](#) manufacturer:

Other Similar products are found below :

[RF0077-000](#) [RF0627-000](#) [RF3301-000](#) [RF3382-000](#) [RF3394-000](#) [RF3399-000](#) [SMD125-2](#) [RF1973-000](#) [RF2531-000](#) [RF2873-000](#) [RF3060-000](#) [RF3311-000](#) [TR600-150Q-B-0.5-0.130](#) [RXE090](#) [5E4795/04-1502](#) [TRF250-080T-B-1.0-0.125](#) [SMD100-2](#) [NIS5431MT1TXG](#) [SMD250-2](#) [RS30-090](#) [RS30-600](#) [RS30-800](#) [RS30-900](#) [RS60RB-160](#) [RS60SB-250](#) [SB250-145](#) [K30U400](#) [0ZCH0110AF2E](#) [BK60-110-DI-E0.6](#) [BK250-120-SZ-E0.6](#) [BK60-010-DI-E0.5](#) [BK250-040-DY-E0.6](#) [RF2631-000](#) [NIS4461MT3TXG](#) [NIS5420MT2TXG](#) [NIS5420MT3TXG](#) [NIS6420MT1TWG](#) [RF5032-000](#) [RF5051-000](#) [RF5105-000](#) [RF5062-000](#) [RF5055-000](#) [RF5052-000](#) [2920L075/72MR](#) [BSMD0603-025-24V](#) [BSMD0402L-005](#) [BSMD0603-010-9V](#) [BSMD1812-020-60V](#) [BSMD2920-400-30V](#) [BSMD0603-010-12V](#)