

MODEL	SPECIFICATION		Page
TR series Short-travel Keyswitches	Short-travel Keyswitches RoHS&REACH Compliant & Halogen Free	SP-001	1/3

Order Information

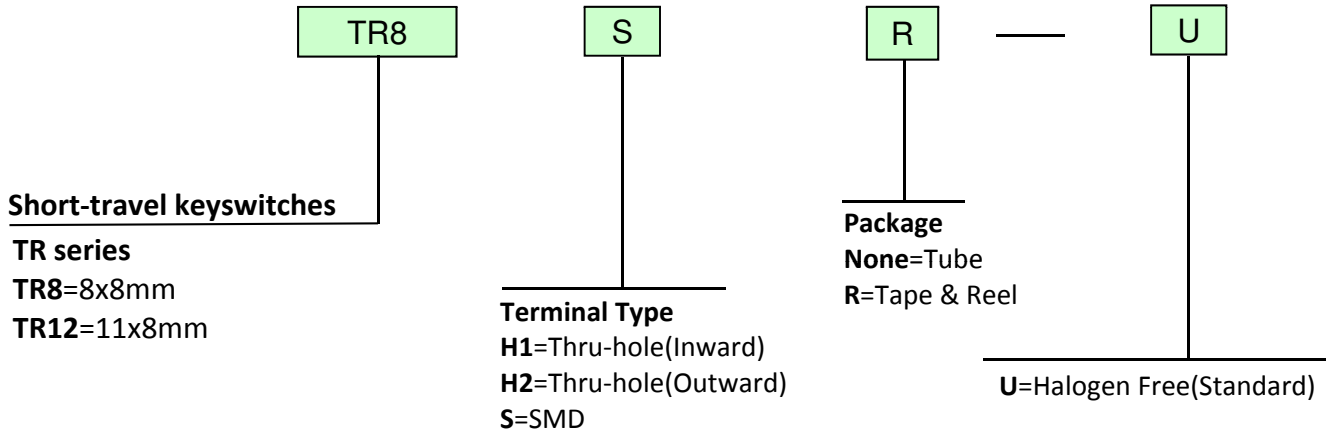

Specifications

◆ Contact Rating42V AC/DC, 100mA
◆ Contact Resistance100mΩ
◆ Insulation Resistance100mΩ at 100 VDC
◆ Dielectric Strength250VDC, 50Hz for the duration of 1 minute
◆ Operating Temperature-40°C to+ 80°C
◆ Mechanical Life5,000,000 operations
◆ Push Force3.5N±0.6N
◆ Travel0.60±0.20mm
◆ Mountingon pc-board
◆ WaterproofMeet IP67

Materials:

◆ Button Silicone, Natural color
◆ Base Thru-hole Thermoplastic UL 94 rate, Blue
SMD Thermoplastic UL 94 rate, Black
◆ Contact Disc. Stainless steel, Silver Plated
◆ Terminal Contact Brass, 1u" Gold-plated
◆ Terminal Brass, Tin-plated

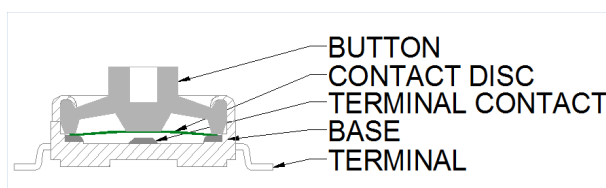

MODEL	SPECIFICATION	Page
TR series Short-travel Keyswitches	Short-travel Keyswitches RoHS&REACH Compliant & Halogen Free	SP-002 2/3

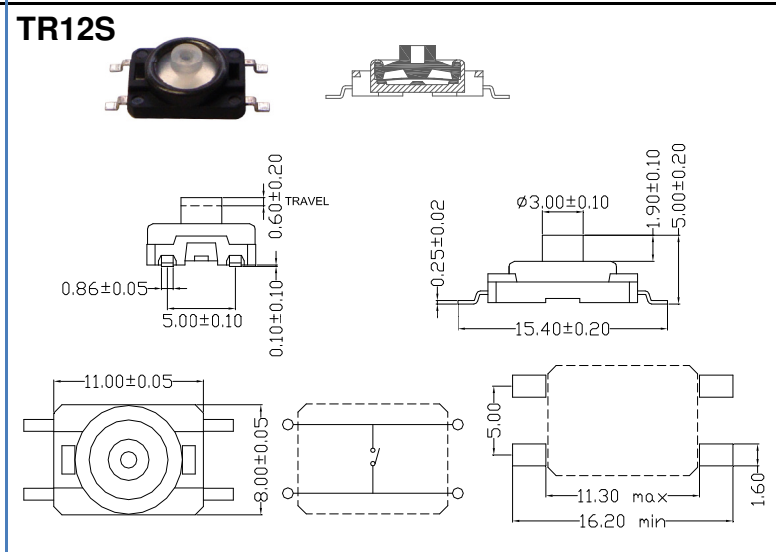
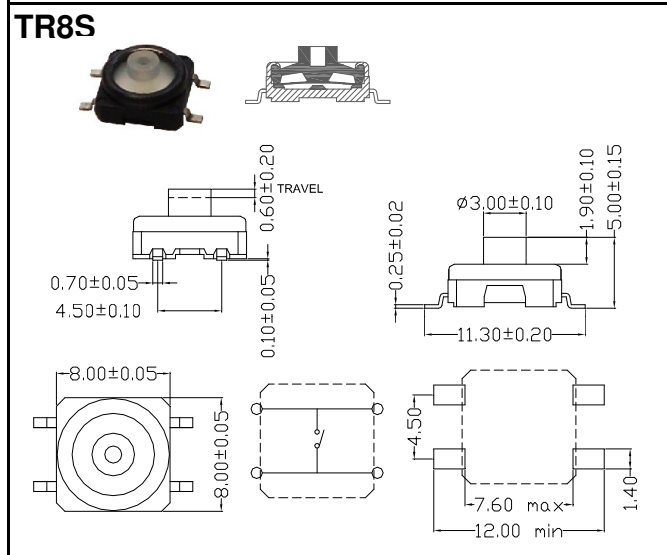
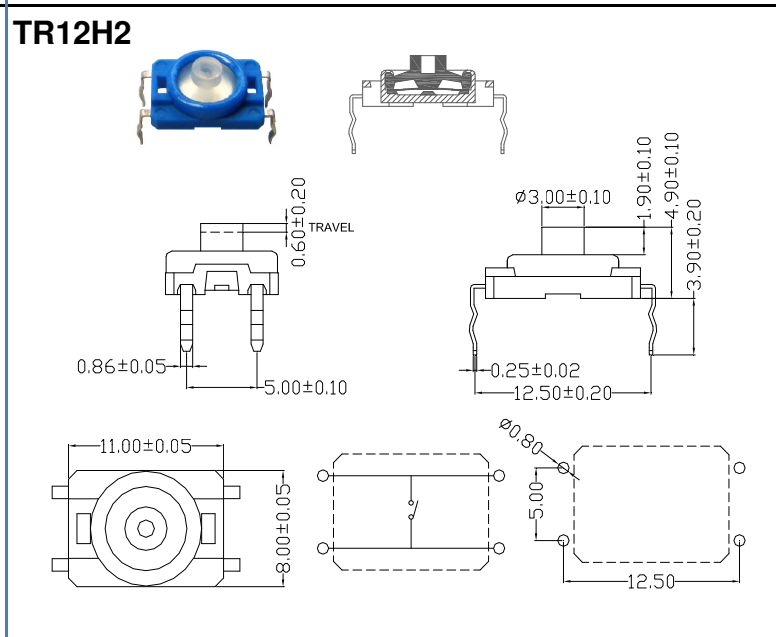
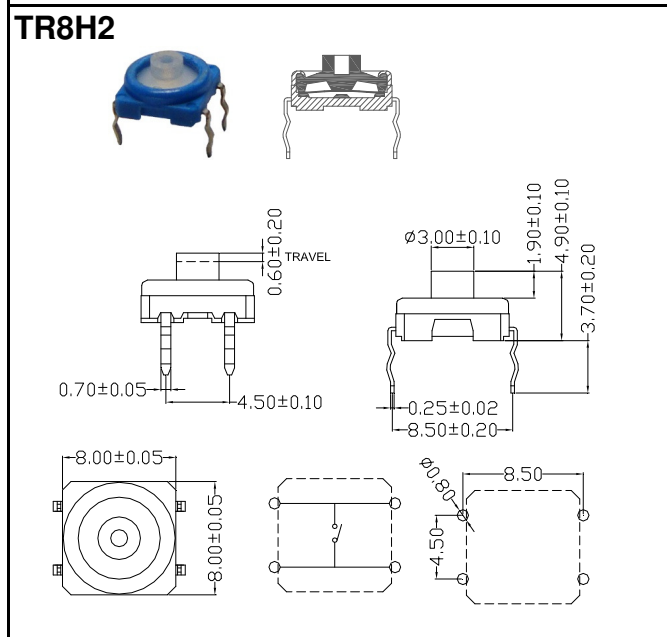
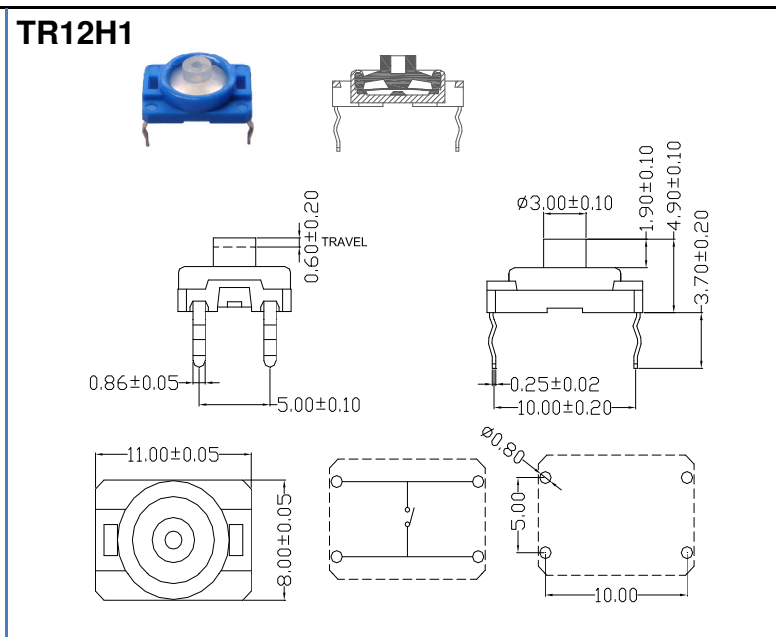
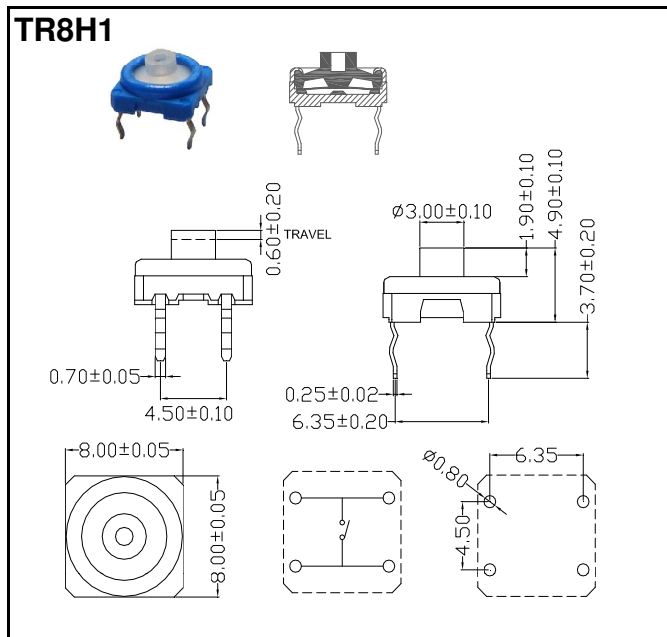

MODEL	SPECIFICATION		Page
TR series	Short-travel Keyswitches	SP-003	3/3
Short-travel Keyswitches	RoHS&REACH Compliant & Halogen Free		

Soldering Information

- ◆ Hand Soldering
Soldering iron 30W or under at 350°C for 3 sec max or at 270°C for 5 sec max.
- ◆ Reflow Soldering
Please refer below "Classification Reflow Soldering Profiles"
Available 1 times process
- ◆ Wave Soldering
Please refer below "Classification Wave Soldering Profiles"

The table copy from IPC/JEDEC J-STD-020 D.1

Profile Feature	Pb-Free Assembly
Preheat / Soak	
Temperature Min (T_{smin})	150°C
Temperature Max (T_{smax})	200°C
Time(t_s) from (T_{smin} to T_{smax})	60 ~120 seconds
Ramp-up Rate (T_L to T_p)	3°C/second max
Liquidous temperature (T_L)	217°C
Time (t_L) maintained above to T_L	60 ~ 150 seconds
Peak package body temperature (T_p)	For users T_p must not exceed the Classification temp:250°C (Package Thickness>2.5mm) For suppliers T_p must equal or exceed the Classification temp:250°C (Package Thickness>2.5mm)
Time (t_p) within 5°C of specified classification temperature (T_c)	30 seconds
Ramp-Down Rate (T_p to T_L)	6°C/second max
Time 25°C to Peak Temperature	8 minutes max
* Tolerance for peak profile temperature(T_p) is defined as a supplier minimum and a user maximum	

- Note 1: All temperatures refer to topside of the package, measured on the package body surface.
- Note 2: Time within 5 °C of actual peak temperature (t_p) specified for the reflow profiles is a "supplier" minimum and "user" maximum.

Box Dimension:

- ◆ Tube57.0cm x 13.0cm x 12.5cm
- ◆ Reel34.0cm x 13.0cm x 15.5cm

- ◆ Tube
2 Box.....58.5cm x 28.0cm x 15.0cm
4 Box.....58.5cm x 28.0cm x 27.0cm
- ◆ Reel36.0cm x 27.5cm x 37.0cm

Classification Reflow Soldering

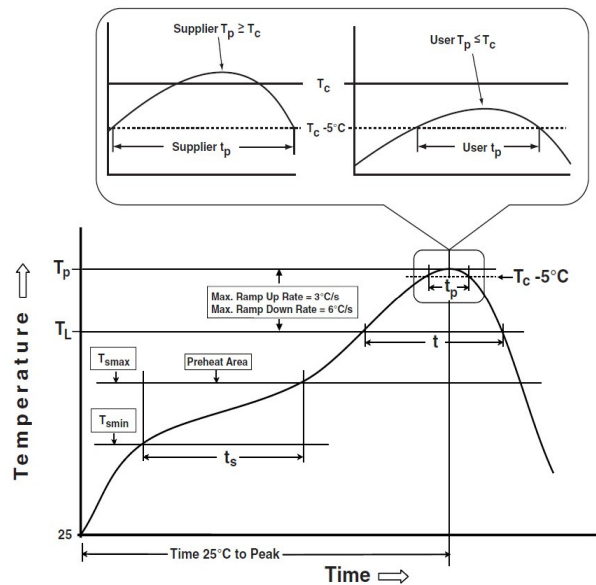

Classification Wave Soldering

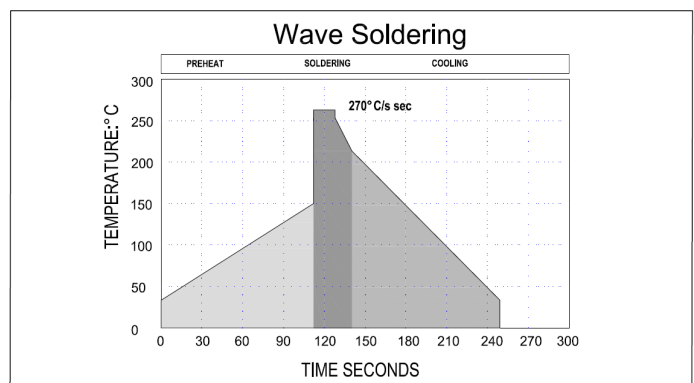

Maximum dwell time in the solder wave (270°C) shall not exceed 5 seconds.

X-ON Electronics

Largest Supplier of Electrical and Electronic Components

Click to view similar products for [Tactile Switches](#) category:

Click to view products by [BIWIN](#) manufacturer:

Other Similar products are found below :

[6407-250V-25273P](#) [ADTSA62NV](#) [B3F-3123](#) [1977177-8](#) [1977266-1](#) [ADTSA63NV](#) [ADTSM21NSVTR](#) [ADTSM25RVTR](#) [ADTSM32NVTR](#)
[ADTSMW64RV](#) [1977120-6](#) [FSMRA4JHA04](#) [GS4.70F300QP](#) [KSC241J](#) [SP DELTA LFS](#) [3FTL600RAS](#) [3FTL640RAS](#) [Y96K132V0FPLFS](#)
[6407-250V-25343P](#) [ADTSM31NVTR](#) [2-1977120-7](#) [TSJW-5.2-260-TR](#) [Y651050400P](#) [KMT011MNGJLHS](#) [70-201.0](#) [ADTSG648NV](#)
[ADTSM62KSVTR](#) [ADTSM648NV](#) [95C06E3RAT](#) [3ATH9Q](#) [FSMRA8JHA04](#) [HARS0073](#) [Y33R411N9FPLFT](#) [Y33R51139FPLFT](#)
[Y31C01402FPLFS](#) [PTS645SK50SMTR92](#) [ADTSM32NVB](#) [KMS233GPWTLFG](#) [Y78B64124FP](#) [Y33A812C5FP LFT](#) [Y56B2D120FP LFS](#)
[PTS645 DVM83-BN125-2 LFS](#) [B3W 1000G](#) [B3F 1002C](#) [B3F 0047H](#) [B3W 1002C](#) [B3F 5001G](#) [B3W 1100C](#) [1-1571563-4](#) [B3F 3150M](#)
[KT11P4SA1M35 LFG SS-FORM](#)