

BRCL4054DME

Rev.A May.-2021

描述 / Descriptions

BRCL4054DME 一款完整的恒定电流/恒定电压线性控制单节锂离子电池充电器，具有电池正负极反接保护功能。其 SOT23-5 封装与较少的外部元件数目使得 BRCL4054DME 成为便携式应用的理想选择。

BRCL4054DME 可以适合 USB 电源和适配器电源工作。

由于采用了内部 PMOSFET 架构，加上防倒充电路，所以不需要外部检测电阻器和隔离二极管。热反馈可对充电电流进行自动调节，以便在大功率操作或高环境温度条件下对芯片温度加以限制。充满电压固定于 4.20V，而充电电流可通过一个电阻器进行外部设置。当电池达到 4.20V 之后，充电电流降至设定值 1/10，BRCL4054DME 将自动终止充电。

当输入电压（交流适配器或 USB 电源）被拿掉时，BRCL4054DME 自动进入一个低电流状态，电池漏电流在 3 μ A 以下。BRCL4054DME 的其他特点包括充电电流监控器、欠压闭锁、自动再充电和两个用于指示充电结束和输入电压接入的状态引脚。

BRCL4054DME is a complete CC/CV linear charger for single cell lithium-ion batteries, It has the function of positive and negative electrode protection for battery. Its SOT23-5 package and low external component count make the BRCL4054DME ideally suited for portable applications. Furthermore, the BRCL4054DME is specifically designed to work within USB power specifications.

No external sense resistor is needed and no blocking diode is required due to the internal P-MOSFET architecture. Thermal feedback regulates the charge current to limit the die temperature during high power operation or high ambient temperature. The charge voltage is fixed at 4.2V, and the charge current can be programmed externally with a single resistor. The BRCL4054DME automatically terminates the charge cycle when the charge current drops to 1/10th the programmed value after the final float voltage is reached.

When the input supply (wall adapter or USB supply) is removed the BRCL4054DME automatically enters a low current state dropping the battery drain current to less than 3 μ A. Other features include charge current monitor, under-voltage lockout, automatic recharge and two status pins to indicate charge and charge termination.

特征 / Features

- ◆ 预设4.20V \pm 1%精度的充电电压
Preset 4.20V charge voltage with \pm 1% accuracy
- ◆ 输入最大耐压：8V
Maximum allowable input voltage is 8V
- ◆ 具有BAT-VIN防倒灌功能
With BAT-VIN anti-backflow function
- ◆ 线性充电模式，内置800mA MOSFET，涓流/恒流/恒压三段式充电，充电电流外部可调
Linear charge mode, built-in 800mA MOSFET, Trickle / Constant current / Constant voltage three stage charging, externally adjustable charging current
- ◆ 支持对0V电池充电
Supports 0V battery charging
- ◆ 短路保护，电池正负极反接保护
Short circuit protection, battery polarity reverse polarity protection
- ◆ 可直接从USB端口给单节锂离子电池充电
Charges single cell Li-ion batteries Directly from USB port

BRCL4054DME

Rev.A May.-2021

特征 / Features

- ◆ 智能温控技术, 充电电流会随温度升高而降低, 130度开始下降, 最低可降至0
Intelligent temperature control technology, charging current will decrease with increasing temperature, 130°C began to decline, the lowest can be reduced to 0
- ◆ 软启动限制了浪涌电流
Soft-Start limits inrush current
- ◆ 自动再充电
Automatic recharge
- ◆ 4KV ESD (HBM mode)
- ◆ 无卤产品。
Halogen-free Product.

用途 / Applications

适用于 USB 电源和适配器电源, 蓝牙应用及其他便捷式设备。
Suitable for USB power and adapter power, Bluetooth applications and other portable devices.

典型应用电路图 / Typical Application

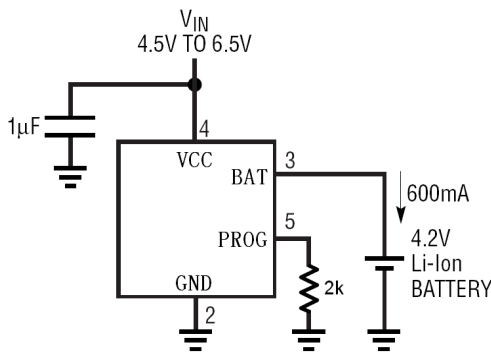

引脚排列 / Pinning



引脚	名称	描述
1	CHRG	充电指示灯/Charging indicator
2	GND	芯片地/Chip ground
3	BAT	电池输入端/Battery input
4	VDD	外部输入直流5V/External input DC 5V
5	PROG	充电电流调整端/Charge current regulator

印章代码 / Marking

见印章说明。 See Marking Instructions.

极限参数 / Absolute Maximum Ratings(Ta=25°C)

参数 Parameter	符号 Symbol	数值 Rating	单位 Unit
VDD to GND	V _{DD}	-0.3~8	V
BAT to GND	V _{BAT}	-0.3~7	V
CHRG to GND	V _{chrg}	-0.3~8	V
PROG to GND	V _{prog}	-0.3~8	V
Storage Temperature	T _{STG}	-50~+125	°C
Operating Temperature Range	T _{opr}	-40~+85	°C
Lead Temperature (Soldering, 10s)	T _{solder}	260	°C

电性能参数 / Electrical Characteristics(除非特别指定, Ta=25°C)

参数 Parameter	符号 Symbol	测试条件 Test Conditions	最小值 Min	典型值 Typ	最大值 Max	单位 Unit
输入电压范围	V _{DD}		4	5	6	V
V _{DD} 从低到高	V _{DD} 掉电监测	V _{DD} >BAT		100		mV
V _{DD} 从高到低		V _{DD} >BAT		30		mV
浮充门槛电压	V _{BAT}	V _{DD} =5V	4.158	4.20	4.242	V
BAT倒灌电流	I _{BAT}	V _{CC} =3.5V V _{bat} =4.2V		±0.5	±5	μA
涓流转恒流	V _{TRKL}	V _{BAT} 从低到高		2.8		V
涓流充电迟滞电压	V _{TRHYS}			100		mV
V _{DD} 欠压闭锁门限	V _{UV}	V _{DD} 从低到高		3.7		V
V _{DD} 欠压闭锁迟滞	V _{UVHYS}			200		mV
手动停机门限电压	V _{msd}			1.2		V
手动停机迟滞电压	V _{msdHYS}			50		mV
涓流时PROG电压	V _{prog1}			0.1		V
大电流时PROG电压	V _{prog2}			1.0		V
过温恢复	OTR	V _{DD} =5V		130		°C

BRCL4054DME

Rev.A May.-2021

工作原理 / Description of the Principle

BRCL4054DME是专门为一节锂离子或锂聚合物电池而设计的线性充电器电路，利用芯片内部的功率晶体管对电池进行恒流和恒压充电。充电电流可以用外部电阻编程设定，最大持续充电电流可达800mA，不需要另加阻流二极管和电流检测电阻。BRCL4054DME包含一个漏极开路输出的充电状态指示端CHRG。

芯片内部的功率管理电路在芯片的结温超过130°C时自动降低充电电流，这个功能可以使用户最大限度的利用芯片的功率处理能力，不用担心芯片过热而损坏芯片或者外部元器件。这样，用户在设计充电电流时，可以不用考虑最坏情况，而只是根据典型情况进行设计就可以了，因为在最坏情况下，BRCL4054DME会自动减小充电电流。

当输入电压大于电源低电压检测阈值时，BRCL4054DME开始对电池充电，CHRG管脚输出低电平，表示充电正在进行，如果电池电压低于2.8V，充电器用小电流对电池进行预充电。当电池电压超过2.8V时，充电器采用恒流模式对电池充电，充电电流由PROG管脚和GND之间的电阻RPROG 确定。当电池电压接近4.2V 电压时，充电电流逐渐减小，BRCL4054DME进入恒压充电模式。当充电电流减小到充电结束阈值时，充电周期结束，CHRG输出高阻态。充电结束阈值是恒流充电电流的10%。

当电池电压降到再充电阈值以下时，自动开始新的充电周期。芯片内部的高精度的电压基准源，误差放大器和电阻分压网络确保电池端调制电压的精度在 1%以内，满足了锂离子电池和锂聚合物电池的要求。当输入电压掉电或者输入电压低于电池电压时，充电器进入低功耗的睡眠模式，电池端消耗的电流小于3uA，从而增加了待机时间。

The BRCL4054DME is a complete CC/CV linear charger for single cell lithium-ion batteries. CC/CV to charger batter by internal MOSFET. It can deliver up to 800mA of charge current .No blocking diode or external current sense resistors required. BRCL4054DME include one Open-Drain charge status Pin: Charge status indicator CHRG.

The internal thermal regulation circuit reduces the programmed charge current if the die temperature attempts to rise above a preset value of approximately 130°C.This feature protects the BRCL4054DME from excessive temperature, and allows the user to push the limits of the power handling capability of a given circuit the external components. Another benefit of adopting thermal regulation is that charge current can be set according to typical, not worst-case, ambient temperatures for a given application with the assurance that the charger will automatically reduce the current in worst-case conditions.

The charge cycle begins when the voltage at the VCC pin rises above the UVLO level, a current set resistor is connected from the PROG pin to ground. The CHRG pin outputs a logic low to indicate that the charge cycle is on going. At the beginning of the charge cycle, if the battery voltage is below 2.8V, the charge is in pre charge mode to bring the cell voltage up to a safe level for charging. The charger goes into the fast charge CC mode once the voltage on the BAT pin rises above 2.8V. In CC mode, the charge current is set by RPROG. When the battery approaches the regulation voltage 4.2V, the charge current begins to decreases the BRCL4054DME enters the CV mode. When the current drops to charge termination threshold, the charge cycle is terminated, and CHRG pin assumes a high impedance state to indicate that the charge cycle is terminated. The charge termination threshold is 10% of the current in CC mode.

工作原理 / Description of the Principle

To restart the charge cycle, remove the input voltage and reapply it. The charge cycle can also be automatically restarted if the BAT pin voltage falls below the recharge threshold. The on-chip reference voltage, error amplifier and the resistor divider provide regulation voltage with 1% accuracy which can meet the requirement of lithium-ion and lithium polymer batteries. When the input voltage is not present, or input voltage is below VBAT, the charger goes into a sleep mode, dropping battery drain current to less than 3 μ A. This greatly reduces the current drain on the battery and increases the standby time.

充电电流是采用一个连接在PROG引脚与地之间的电阻器来设定的,设定电阻器和充电电流采用下列公式来计算。根据需要的充电电流来确定电阻器阻值。

The charge current is programmed using a single resistor from the PROG pin to ground. The program resistor and the charge current are calculated using the following equations.

$$R_{\text{prog}}(\text{kohm}) = \frac{1200}{I_{\text{bat}}(\text{mA})} \text{ (误差} \pm 10\% \text{)}$$

外形尺寸图 / Package Dimensions

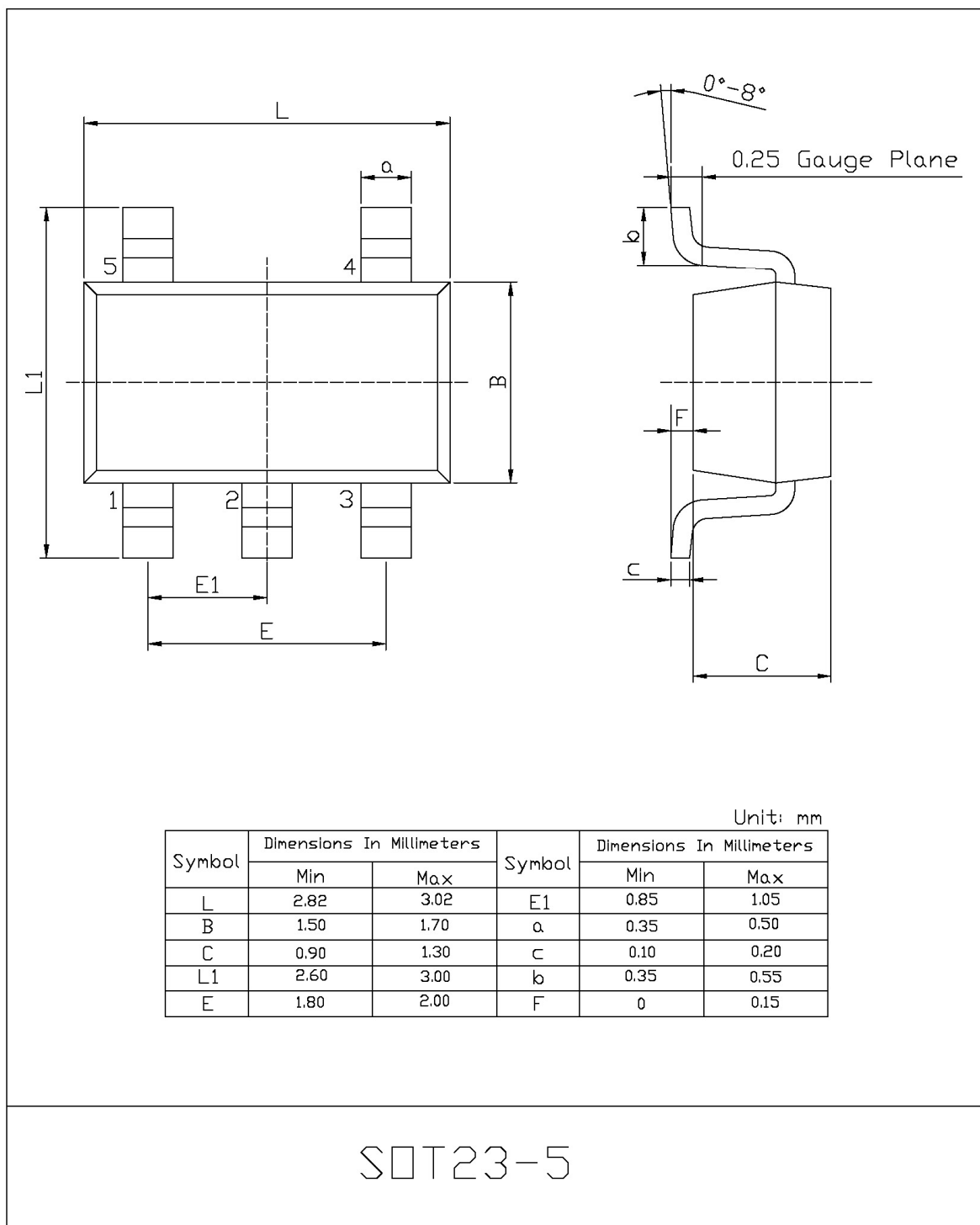

印章说明 / Marking Instructions

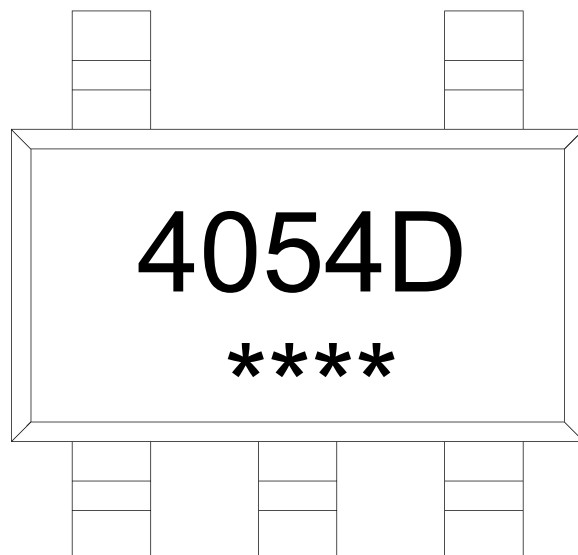

说明：

4054D： 为产品型号

****： 为生产批号代码，随生产批号变化。

Note:

4054D: Product Type.

****: Lot No. Code, code change with Lot No.

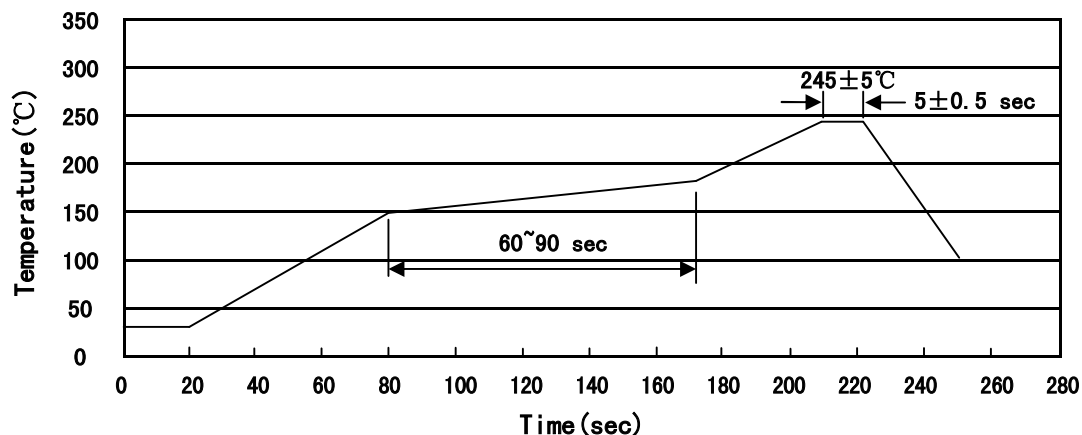
回流焊温度曲线图(无铅) / Temperature Profile for IR Reflow Soldering(Pb-Free)

说明：

- 1、预热温度 150 ~ 180°C，时间 60 ~ 90sec；
- 2、峰值温度 245±5°C，时间持续为 5±0.5sec；
- 3、焊接制程冷却速度为 2 ~ 10°C/sec.

Note:

- 1.Preheating:150~180°C, Time:60~90sec.
- 2.Peak Temp.:245±5°C, Duration:5±0.5sec.
3. Cooling Speed: 2~10°C/sec.

耐焊接热试验条件 / Resistance to Soldering Heat Test Conditions

温度：260±5°C

时间：10±1 sec.

Temp.:260±5°C

Time:10±1 sec

包装规格 / Packaging SPEC.

卷盘包装 / REEL

Package Type 封装形式	Units 包装数量					Dimension 包装尺寸 (unit : mm ³)		
	Units/Reel 只/卷盘	Reels/Inner Box 卷盘/盒	Units/Inner Box 只/盒	Inner Boxes/Outer Box 盒/箱	Units/Outer Box 只/箱	Reel	Inner Box 盒	Outer Box 箱
SOT23-5/6	3,000	10	30,000	4	120,000	7" × 8	210×205×205	445×230×435

使用说明 / Notices

X-ON Electronics

Largest Supplier of Electrical and Electronic Components

Click to view similar products for [Battery Management](#) category:

Click to view products by [Blue Rocket](#) manufacturer:

Other Similar products are found below :

[LV5117AV-TLM-H](#) [NCP1855FCCT1G](#) [FAN54063UCX](#) [MP2615GQ-P](#) [LC05132C01NMTTTG](#) [ISL78714ANZ](#) [CM1104-EH](#) [CM1104-DBB](#)
[CM1104-MBB](#) [XC6801A421MR-G](#) [ISL95521BHRZ](#) [MP2639AGR-P](#) [S-82D1AAE-A8T2U7](#) [S-82D1AAA-A8T2U7](#) [S-8224ABA-I8T1U](#)
[MP2615CGQ-P](#) [MC33772CTC0AE](#) [EG1205](#) [EA3036CQBR](#) [GX4056](#) [GX4054](#) [GX4057](#) [HP4059D6-42Y](#) [HP4059D6-44Y](#) [HP2601D8-68](#)
[CM1124-EAC](#) [ME4064AM5G-N](#) [ME4084AM5G](#) [ME4084BN8BG](#) [ME4074CM5G](#) [RY2231B1D4](#) [FM5324GA](#) [FM4057E42](#) [TP4054](#)
[TP4056](#) [TP4054S5-2](#) [WST4054](#) [WSP4056](#) [AP5056SPER](#) [FH8209](#) [FH8614G1](#) [FH8206](#) [FH8210A](#) [XB7608AJ](#) [DW01A](#) [LR4054-T](#)
[ME4312CSG](#) [PJ4054B](#) [BRCL3230BME](#) [LP28013SQVF](#)