

1.5SMBJ / 1.5HSMBJ Series

Transient
Voltage Suppressor

Features

- Excellent clamping capability
- Low leakage current
- Low capacitance
- High surge capability
- Glass passivated chip
- Epoxy resin package
- Built-in strain relief
- Will not fatigue
- RoHS Compliant
- “H” Prefix is for Automotive applications, AEC-Q101 qualified

Package

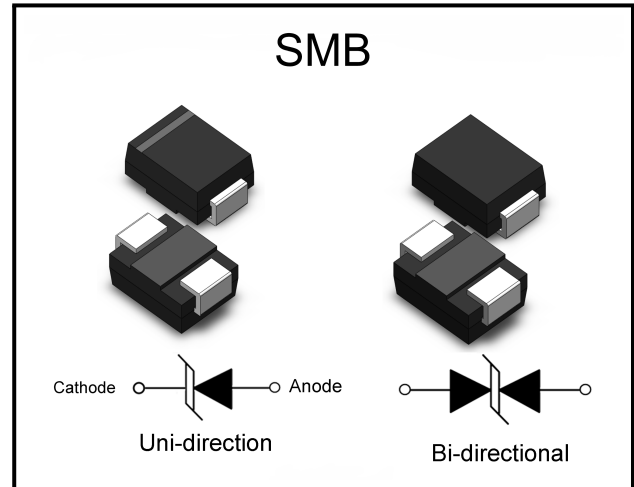

Mechanical Characteristics

- Package: SMB plastic package
- Lead Finish: Matte Tin
- Case Material: Epoxy Molding Compound
- UL Flammability Classification Rating 94V-0
- Moisture Sensitivity: Level 1 per J-STD-020

Applications

- Telecom
- Computer
- Industrial electronic
- Consumer electronic
- Automotive electronic

Making Code

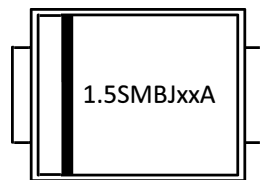

Unidirection

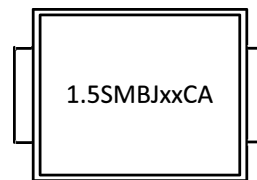

Bidirection

Summary of Packing Options

Package	Packing Description	Packing Quantity	Industry Standard
SMB	Tape/Reel, 13" reel	3000	EIA-481-1
	Tape/Reel, 7" reel	500	EIA-481-1

**BORN SEMICONDUCTOR, INC. ALL
RIGHT RESERVED**

Specifications are subject to change without notice.

Please refer to <http://www.born-tw.com> for current information. **Revision: 2022-Jan-1-A**



Electrical Parameters

Parameter	Definition
C_J	Junction Capacitance - typical capacitance measured with 0V or V_R bias
I_{PP}	Peak Pulse Current - maximum rated peak impulse current
V_C	Clamping Voltage - Peak voltage measured across the suppressor at a specified I_{ppm}
V_{BR}	Breakdown Voltage - Maximum voltage that flows though the TVS at a specified test current (I_T)
I_R	Leakage Current - maximum peak off-state current measured at V_R
V_R	Peak Off-state Voltage - maximum voltage that can be applied while maintaining off state

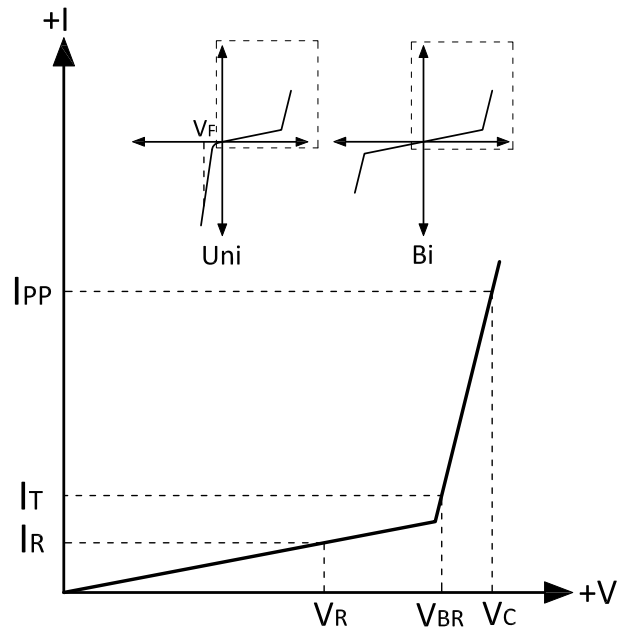

Absolute Maximum Ratings ($T_A=+25^{\circ}\text{C}$, unless otherwise noted)

Parameter	Symbol	Value	Units
Peak Pulse Power Dissipation (Note1,2)	P_{PPM}	1500	W
Steady State Power Dissipation (Note3)	P_D	5	W
Peak Forward Surge Current (Note4)	I_{FSM}	150	A
Maximum Instantaneous Forward Voltage at 50A (Note5)	V_{FM}	5	V
Typical Thermal Resistance Junction to Lead	$R_{\theta JL}$	20	$^{\circ}\text{C/W}$
Typical Thermal Resistance Junction to Ambient	$R_{\theta JA}$	100	$^{\circ}\text{C/W}$
Operating Temperature Range	T_J	-55 to 150	$^{\circ}\text{C}$
Storage Temperature Range	T_{STG}	-55 to 150	$^{\circ}\text{C}$

Notes:

- (1) Non-repetitive current pulse , 10/1000us Waveform.
- (2) Mounted on copper pad area of 5×5mm to each terminal.
- (3) Infinite HeatSink at $T_A = 50^{\circ}\text{C}$
- (4) Measured on 8.3ms single half sine wave or equivalent square wave, duty cycle=4 perminute maximum.
- (5) For UnidirectionalOnly, $V_{FW} < 3.5\text{V}$ for $V_{BR} \leq 200\text{V}$ and $V_{FM} < 5.0\text{V}$ for $V_{BR} \geq 201\text{V}$.





1.5SMBJ / 1.5HSMBJ Series

**Transient
Voltage Suppressor**

Electrical Characteristics ($T_A=+25^{\circ}\text{C}$, unless otherwise noted)

Part Number	Part Number	Reverse Stand-Off Voltage	Breakdown Voltage $V_{BR}@I_T$		Test Current I_T	Maximum Clamping Voltage $V_C @ I_{PP}$	Maximum Peak Pulse Current I_{PP}	Maximum Reverse Leakage $I_R @ V_R$
			Min.(V)	Max.(V)				
(Uni)	(Bi)	(V)			(mA)	(V)	(A)	(μA)
1.5SMBJ5.0A 1.5HSMBJ5.0A	1.5SMBJ5.0CA 1.5HSMBJ5.0CA	5	6.4	7	10	9.2	163.0	800
1.5SMBJ6.0A 1.5HSMBJ6.0A	1.5SMBJ6.0CA 1.5HSMBJ6.0CA	6	6.67	7.37	10	10.3	145.6	800
1.5SMBJ6.5A 1.5HSMBJ6.5A	1.5SMBJ6.5CA 1.5HSMBJ6.5CA	6.5	7.22	7.98	10	11.2	134.0	500
1.5SMBJ7.0A 1.5HSMBJ7.0A	1.5SMBJ7.0CA 1.5HSMBJ7.0CA	7	7.78	8.6	10	12	125.0	200
1.5SMBJ7.5A 1.5HSMBJ7.5A	1.5SMBJ7.5CA 1.5HSMBJ7.5CA	7.5	8.33	9.21	1	12.9	116.3	100
1.5SMBJ8.0A 1.5HSMBJ8.0A	1.5SMBJ8.0CA 1.5HSMBJ8.0CA	8	8.89	9.83	1	13.6	110.3	50
1.5SMBJ8.5A 1.5HSMBJ8.5A	1.5SMBJ8.5CA 1.5HSMBJ8.5CA	8.5	9.44	10.4	1	14.4	104.2	20
1.5SMBJ9.0A 1.5HSMBJ9.0A	1.5SMBJ9.0CA 1.5HSMBJ9.0CA	9	10	11.1	1	15.4	97.4	10
1.5SMBJ10A 1.5HSMBJ10A	1.5SMBJ10CA 1.5HSMBJ10CA	10	11.1	12.3	1	17	88.2	5
1.5SMBJ11A 1.5HSMBJ11A	1.5SMBJ11CA 1.5HSMBJ11CA	11	12.2	13.5	1	18.2	82.4	1
1.5SMBJ12A 1.5HSMBJ12A	1.5SMBJ12CA 1.5HSMBJ12CA	12	13.3	14.7	1	19.9	75.4	1
1.5SMBJ13A 1.5HSMBJ13A	1.5SMBJ13CA 1.5HSMBJ13CA	13	14.4	15.9	1	21.5	69.8	1
1.5SMBJ14A 1.5HSMBJ14A	1.5SMBJ14CA 1.5HSMBJ14CA	14	15.6	17.2	1	23.2	64.7	1
1.5SMBJ15A 1.5HSMBJ15A	1.5SMBJ15CA 1.5HSMBJ15CA	15	16.7	18.5	1	24.4	61.5	1
1.5SMBJ16A 1.5HSMBJ16A	1.5SMBJ16CA 1.5HSMBJ16CA	16	17.8	19.7	1	26	57.7	1
1.5SMBJ17A 1.5HSMBJ17A	1.5SMBJ17CA 1.5HSMBJ17CA	17	18.9	20.9	1	27.6	54.4	1
1.5SMBJ18A 1.5HSMBJ18A	1.5SMBJ18CA 1.5HSMBJ18CA	18	20	22.1	1	29.2	51.4	1

**BORN SEMICONDUCTOR, INC. ALL
RIGHT RESERVED**

Specifications are subject to change without notice.

Please refer to <http://www.born-tw.com> for current information.

Revision: 2022-Jan-1-A





1.5SMBJ / 1.5HSMBJ Series

Transient Voltage Suppressor

Electrical Characteristics (T_A=+25°C, unless otherwise noted)

Part Number	Part Number	Reverse Stand-Off Voltage	Breakdown Voltage		Test Current I _T	Maximum Clamping Voltage V _C @ I _{pp}	Maximum Peak Pulse Current I _{pp}	Maximum Reverse Leakage I _R @ V _R
			Min.(V)	Max.(V)				
(Uni)	(Bi)	(V)			(mA)	(V)	(A)	(uA)
1.5SMBJ20A 1.5HSMBJ20A	1.5SMBJ20CA 1.5HSMBJ20CA	20	22.2	24.5	1	32.4	46.3	1
1.5SMBJ22A 1.5HSMBJ22A	1.5SMBJ22CA 1.5HSMBJ22CA	22	24.4	26.9	1	35.5	42.3	1
1.5SMBJ24A 1.5HSMBJ24A	1.5SMBJ24CA 1.5HSMBJ24CA	24	26.7	29.5	1	38.9	38.6	1
1.5SMBJ26A 1.5HSMBJ26A	1.5SMBJ26CA 1.5HSMBJ26CA	26	28.9	31.9	1	42.1	35.6	1
1.5SMBJ28A 1.5HSMBJ28A	1.5SMBJ28CA 1.5HSMBJ28CA	28	31.1	34.4	1	45.4	33.1	1
1.5SMBJ30A 1.5HSMBJ30A	1.5SMBJ30CA 1.5HSMBJ30CA	30	33.3	36.8	1	48.4	31.0	1
1.5SMBJ33A 1.5HSMBJ33A	1.5SMBJ33CA 1.5HSMBJ33CA	33	36.7	40.6	1	53.3	28.2	1
1.5SMBJ36A 1.5HSMBJ36A	1.5SMBJ36CA 1.5HSMBJ36CA	36	40	44.2	1	58.1	25.8	1
1.5SMBJ40A 1.5HSMBJ40A	1.5SMBJ40CA 1.5HSMBJ40CA	40	44.4	49.1	1	64.5	23.3	1
1.5SMBJ43A 1.5HSMBJ43A	1.5SMBJ43CA 1.5HSMBJ43CA	43	47.8	52.8	1	69.4	21.6	1
1.5SMBJ45A 1.5HSMBJ45A	1.5SMBJ45CA 1.5/SMBJ45CA	45	50	55.3	1	72.7	20.6	1
1.5SMBJ48A 1.5HSMBJ48A	1.5SMBJ48CA 1.5HSMBJ48CA	48	53.3	58.9	1	77.4	19.4	1
1.5SMBJ51A 1.5HSMBJ51A	1.5SMBJ51CA 1.5HSMBJ51CA	51	56.7	62.7	1	82.4	18.2	1
1.5SMBJ54A 1.5HSMBJ54A	1.5SMBJ54CA 1.5HSMBJ54CA	54	60	66.3	1	87.1	17.2	1
1.5SMBJ58A 1.5HSMBJ58A	1.5SMBJ58CA 1.5HSMBJ58CA	58	64.4	71.2	1	93.6	16.1	1
1.5SMBJ60A 1.5HSMBJ60A	1.5SMBJ60CA 1.5HSMBJ60CA	60	66.7	73.7	1	96.8	15.5	1
1.5SMBJ64A 1.5HSMBJ64A	1.5SMBJ64CA 1.5HSMBJ64CA	64	71.1	78.6	1	103	14.6	1





1.5SMBJ / 1.5HSMBJ Series

Transient
Voltage Suppressor

Electrical Characteristics ($T_A=+25^{\circ}\text{C}$, unless otherwise noted)

Part Number	Part Number	Reverse Stand-Off Voltage	Breakdown Voltage $V_{BR}@I_T$		Test Current I_T	Maximum Clamping Voltage $V_C @ I_{PP}$	Maximum Peak Pulse Current I_{PP}	Maximum Reverse Leakage $I_R @ V_R$
			Min.(V)	Max.(V)				
(Uni)	(Bi)	(V)			(mA)	(V)	(A)	(μA)
1.5SMBJ70A 1.5HSMBJ70A	1.5SMBJ70CA 1.5HSMBJ70CA	70	77.8	86	1	113	13.3	1
1.5SMBJ75A 1.5HSMBJ75A	1.5SMBJ75CA 1.5HSMBJ75CA	75	83.3	92.1	1	121	12.4	1





1.5SMBJ / 1.5HSMBJ Series

Transient Voltage Suppressor

Ratings and Characteristic Curves ($T_A=+25^\circ\text{C}$, unless otherwise noted)

Figure 1: Peak Pulse Power Rating

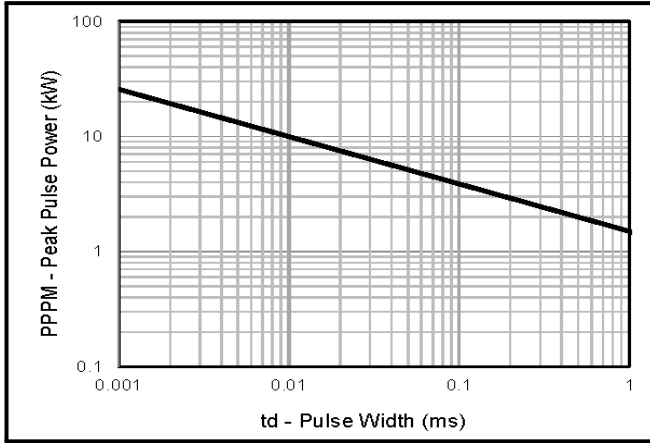

Figure 2: Pulse Derating Curve

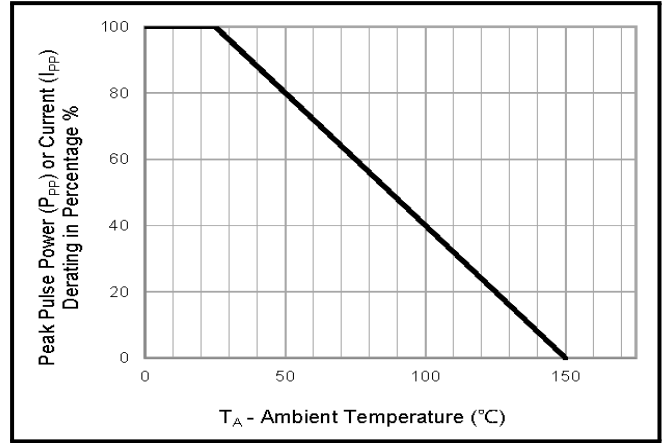

Figure 3: Pulse Waveform

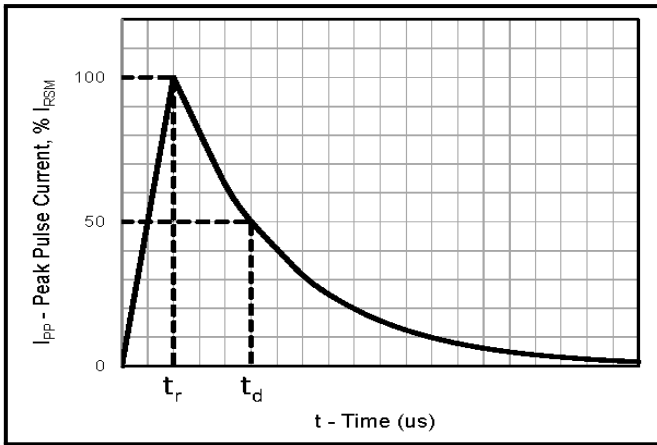

Figure 4: Typical Junction Capacitance

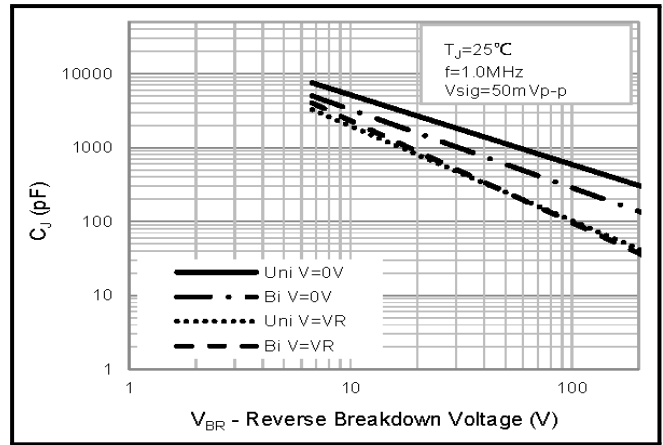

Figure 5: Steady State Power Dissipation Derating Curve

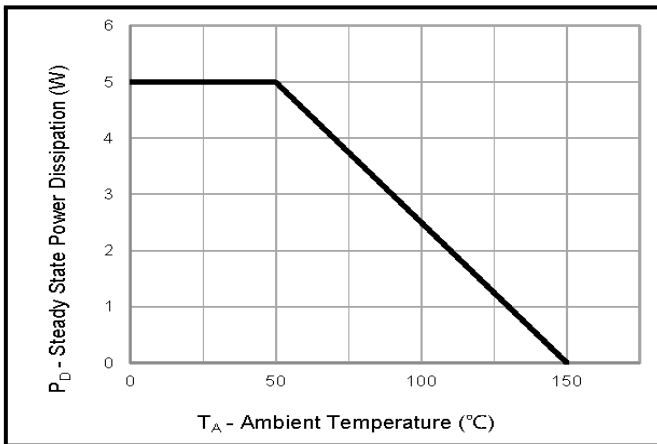
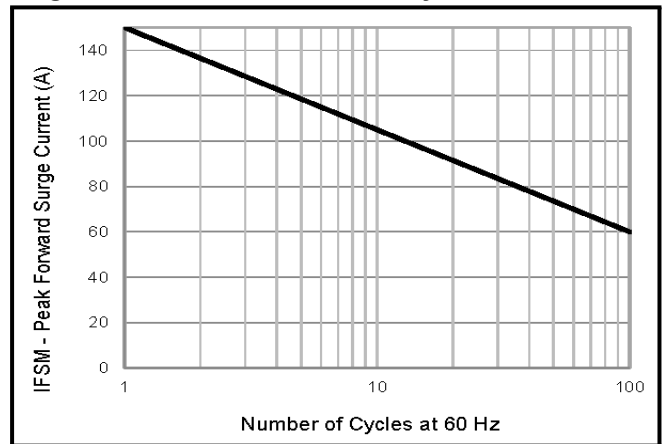

Figure 6: Maximum Non-Repetitive Peak Forward Surge Current Uni-Directional Only





1.5SMBJ / 1.5HSMBJ Series

Transient
Voltage Suppressor

Soldering Parameters

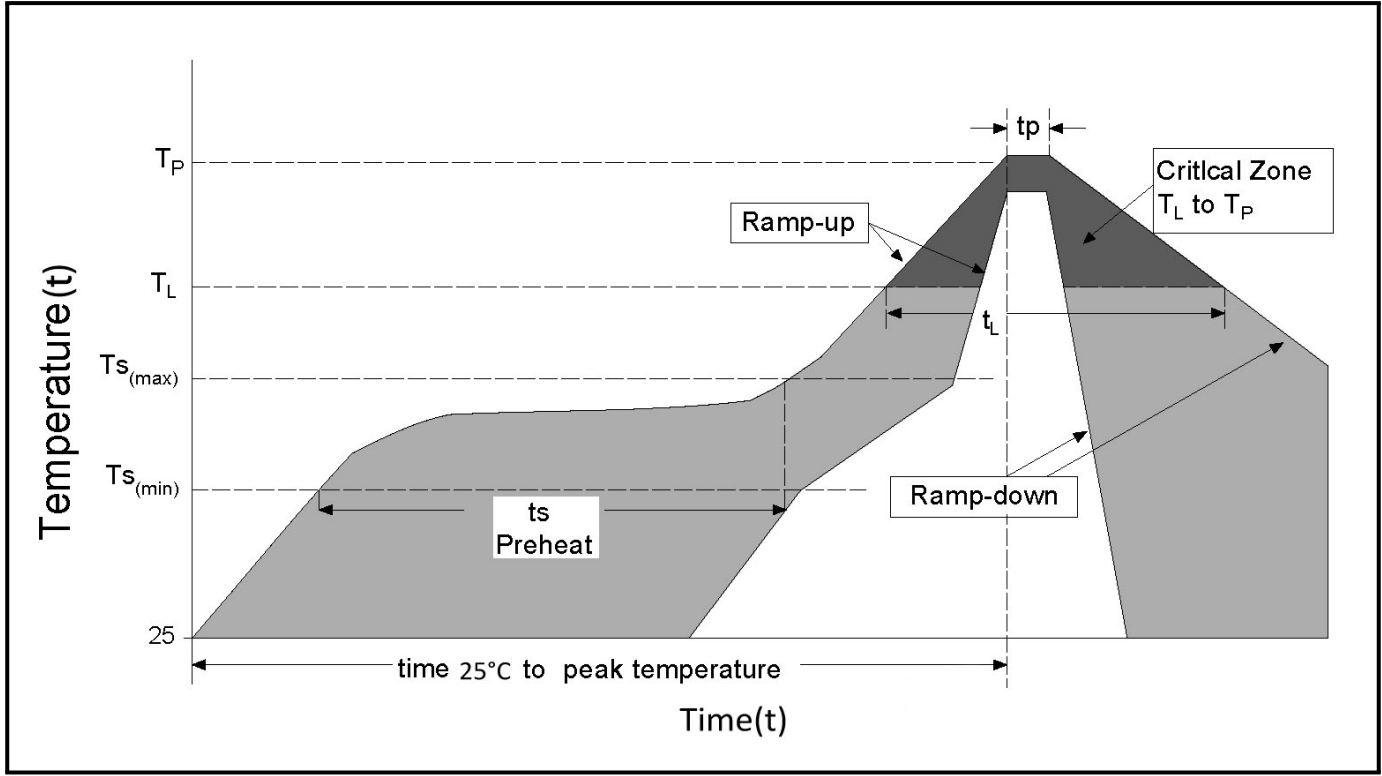

Reflow Condition		Lead-free assembly
Pre Heat	- Temperature Min ($T_{S(min)}$)	150°C
	- Temperature Max ($T_{S(max)}$)	200°C
	- Time (min to max) (t_s)	60 - 180 secs
Average ramp up rate (Liquidus Temp (T_L) to peak)		3°C/second max
$T_{S(max)}$ to T_L - Ramp-up Rate		3°C/second max
Reflow	- Temperature (T_L) (Liquidus)	217°C
	- Time (t_L)	60 - 150 secs
Peak Temperature (T_P)		260 ^{+0/-5} °C
Time within 5°C of actual peak Temperature (t_p)		20 - 40 secs
Ramp-down Rate		6°C/second max
Time 25°C to peak Temperature (t)		8 minutes Max.
Do not exceed		260°C



1.5SMBJ / 1.5HSMBJ Series

Transient
Voltage Suppressor

Outline Drawing – SMB

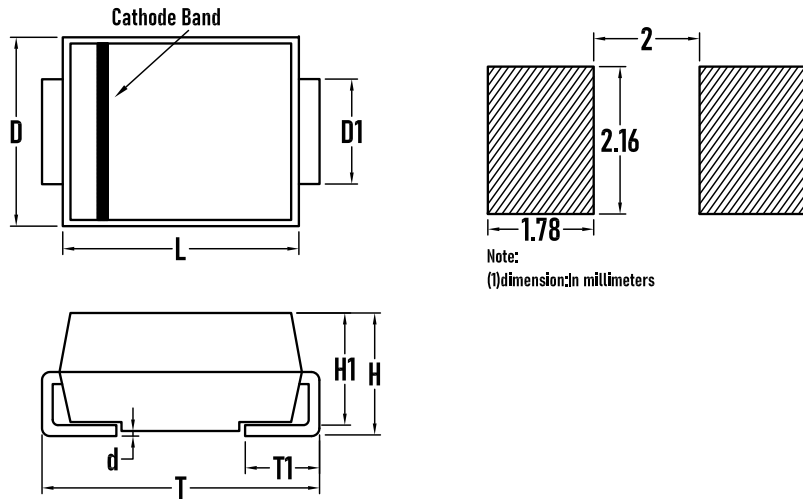

SYMBOL	MILLIMETER		Inches	
	MIN	MAX	MIN	MAX
D	3.5	3.7	0.138	0.146
D1	1.9	2.1	0.075	0.083
T	5.1	5.48	0.201	0.216
T1	1.0	1.6	0.039	0.063
d	–	0.2	–	0.008
H1	2.15	2.35	0.085	0.093
H	2.2	2.45	0.087	0.096
L	4.4	4.6	0.173	0.181

Packaging Tape - SMB

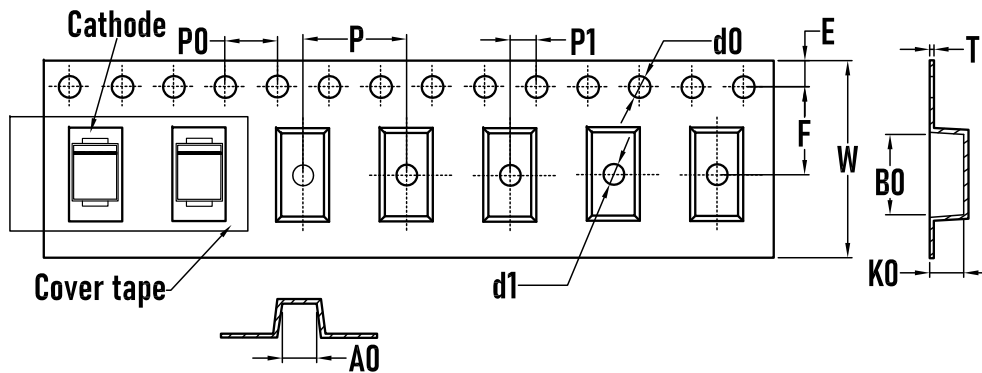

SYMBOL	MILLIMETER
A0	3.60±0.1
B0	5.45±0.1
d0	1.50±0.1
d1	1.50±0.1
E	1.75±0.1
F	5.50±0.1
K0	2.30±0.1
P	8.00±0.1
P0	4.00±0.1
P1	2.00±0.1
W	12.00±0.1
T	0.22±0.02

Packaging Reel

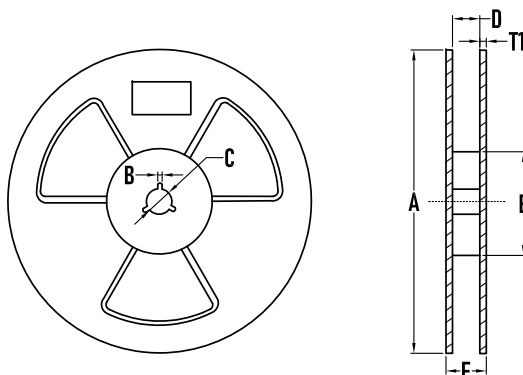

SYMBOL	MILLIMETER
A	323±2
B	3.0±0.2
C	15.0±0.5
D	13±2
E	73±2
T1	2.2±0.2
Quantity	3000PCS

**BORN SEMICONDUCTOR, INC. ALL
RIGHT RESERVED**

Specifications are subject to change without notice.

Please refer to <http://www.born-tw.com> for current information.

Revision: 2022-Jan-1-A

