

**Features**

- 75Watts peak pulse power (tp = 8/20μs)
- Bidirectional configurations
- Solid-state silicon-avalanche technology
- Low clamping Voltage
- Low leakage current
- Protection one data/power line
- IEC 61000-4-2 ±30kV contact ; ±30kV air
- IEC 61000-4-4 (EFT) 40A (5/50ns)
- IEC 61000-4-5 (Lightning) 5A (8/20μs)

**Package**

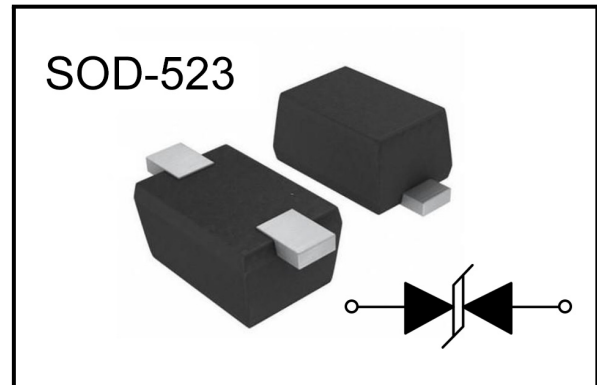

**Applications**

- Microprocessor based equipment
- Personal Digital Assistants (PDA's)
- Notebooks, Desktops, and Servers
- Portable Instrumentation

**Mechanical Characteristics**

- SOD523 package
- Molding compound flammability rating: UL 94V-0
- Packaging: Tape and Reel
- RoHS/WEEE Compliant

**Marking**

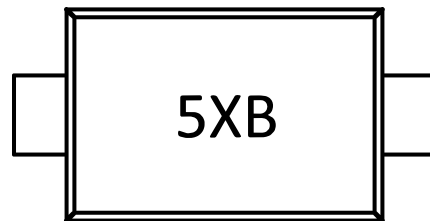

**Ordering information**

Order code	Package	Base qty	Delivery mode
BNAZ5125-01H	SOD-523	5k	Tape and reel



### Electrical Parameters ( $T_A = 25^\circ\text{C}$ unless otherwise noted)

Symbol	Parameter
$I_{PP}$	Maximum Reverse Peak Pulse Current
$V_C$	Clamping Voltage @ $I_{PP}$
$V_{RWM}$	Peak Reverse Working Voltage
$I_R$	Reverse Leakage Current @ $V_{RWM}$
$V_{BR}$	Breakdown Voltage @ $I_T$
$I_T$	Test Current

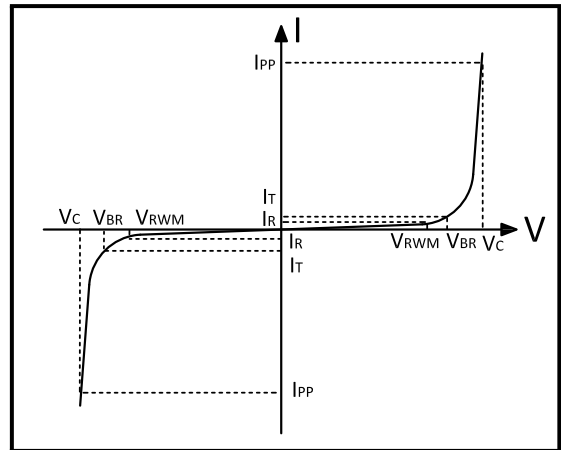

Note: 8/20us pulse Waveform.

### Absolute Maximum Rating

Rating	Symler	Value	Units
Peak Pulse Power ( $t_p = 8/20\mu\text{s}$ )	$P_{PP}$	75	Watts
Peak Pulse Current ( $t_p = 8/20\mu\text{s}$ )	$I_{PP}$	5.0	A
ESD per IEC 61000-4-2 (Air)	$V_{ESD}$	30	KV
ESD per IEC 61000-4-2 (Contact)		30	
Lead Soldering Temperature	$T_L$	260(10seconds)	$^\circ\text{C}$
Junction Temperature	$T_J$	-55 to + 150	$^\circ\text{C}$
Storage Temperature	$T_{stg}$	-55 to + 150	$^\circ\text{C}$

### Electrical Characteristics

Parameter	Symler	Conditions	Min	Typical	Max	Units
Reverse Stand-Off Voltage	$V_{RWM}$	–	–	–	5.0	V
Reverse Breakdown Voltage	$V_{BR}$	$I_T = 1\text{mA}$	6.2	7.2	9.5	V
Reverse Leakage Current	$I_R$	$V_{RWM} = 5\text{V}, T = 25^\circ\text{C}$	–	–	0.5	$\mu\text{A}$
Clamping Voltage	$V_C$	$I_{PP} = 5.0\text{A}, t_p = 8/20\mu\text{s}$	–	12	15	V
Junction Capacitance	$C_j$	$V_R = 0\text{V}, f = 1\text{MHZ}$	–	8	10	pF





**Typical Characteristics**

**Figure 1: Peak Pulse Power vs. Pulse Time**

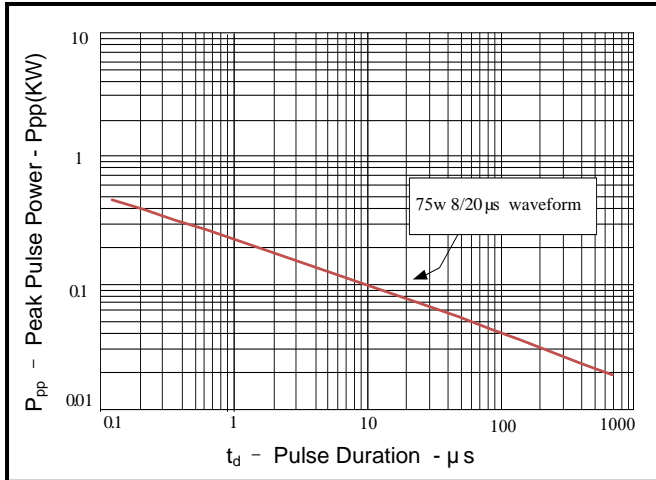

**Figure 2: Power Derating Curve**

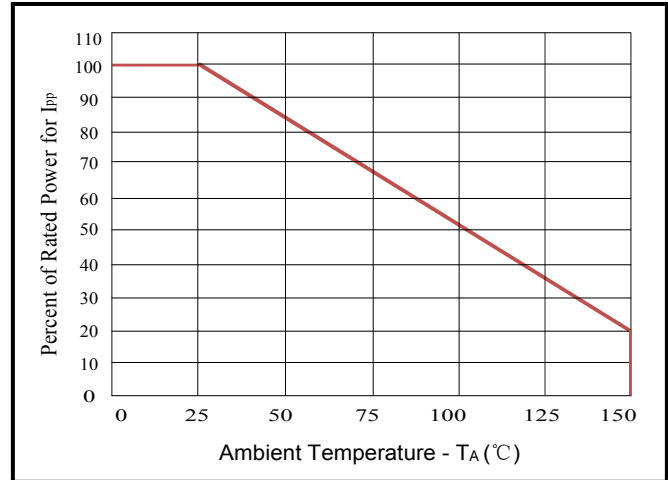

**Figure 3: Pulse Waveform**

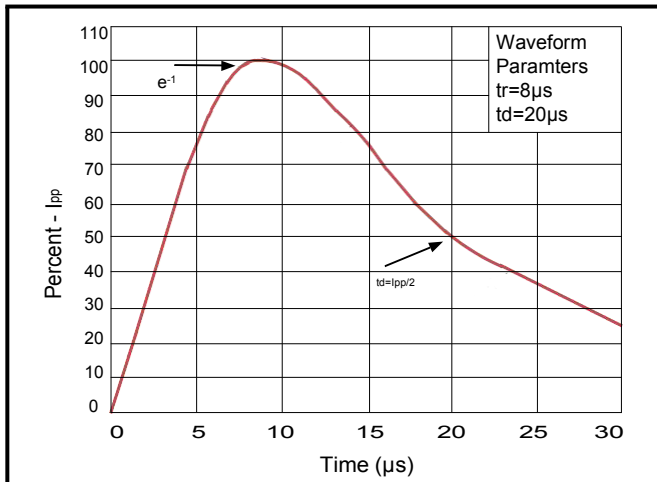

**Figure 4: Clamping Voltage vs. Ipp**

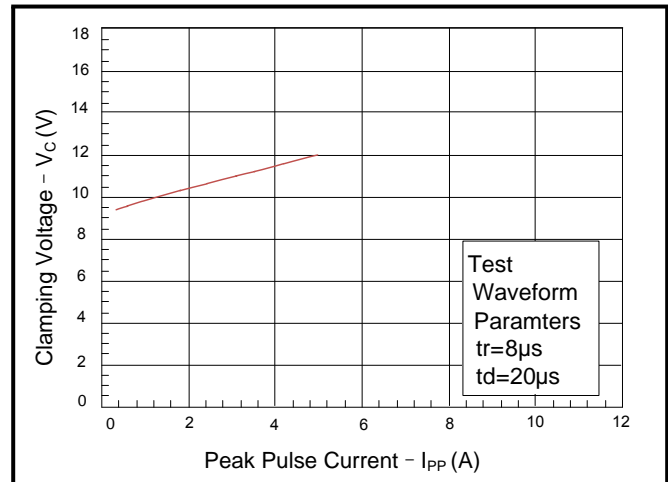

**BNAZ5125-01H**

ESD Protection Diode

**Outline Drawing – SOD-523**

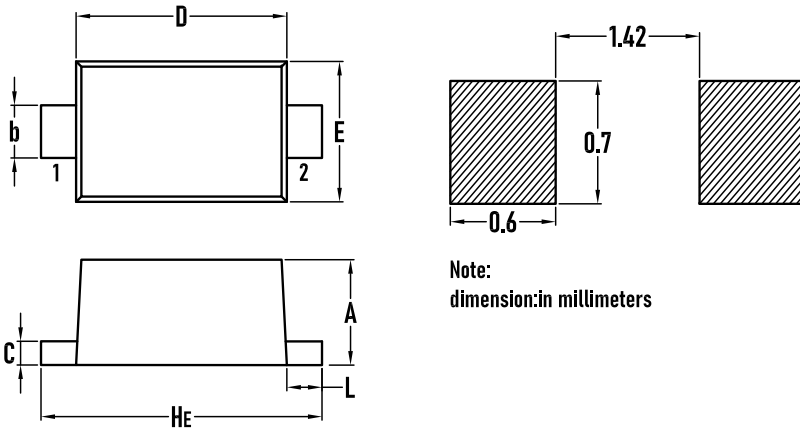

SYMBOL	MILLIMETER		INCHES	
	MIN.	MAX.	MIN.	MAX.
A	0.50	0.70	0.020	0.028
b	0.25	0.35	0.010	0.014
C	0.07	0.20	0.0028	0.0079
D	1.10	1.30	0.043	0.051
E	0.70	0.90	0.028	0.035
H <sub>E</sub>	1.50	1.70	0.059	0.067
L	0.15	0.25	0.006	0.010

**Packaging Tape - SOD-523**

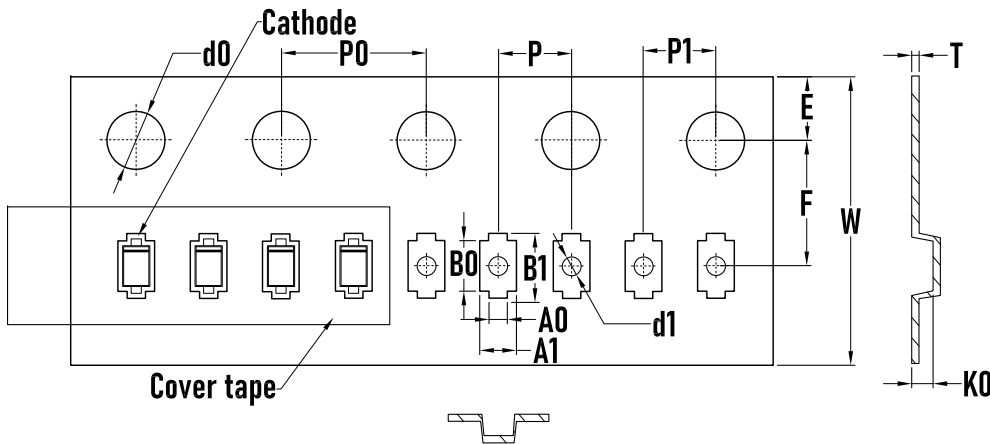

SYMBOL	MILLIMETER
A0	0.50±0.10
A1	1.00±0.10
B0	1.30±0.10
B1	1.80±0.10
d0	1.55±0.10
d1	0.50±0.05
E	1.75±0.10
F	3.50±0.10
K0	0.65±0.10
P	2.00±0.10
P0	4.00±0.10
P1	2.00±0.10
W	8.00±0.30
T	0.2 ±0.05

**Packaging Reel**

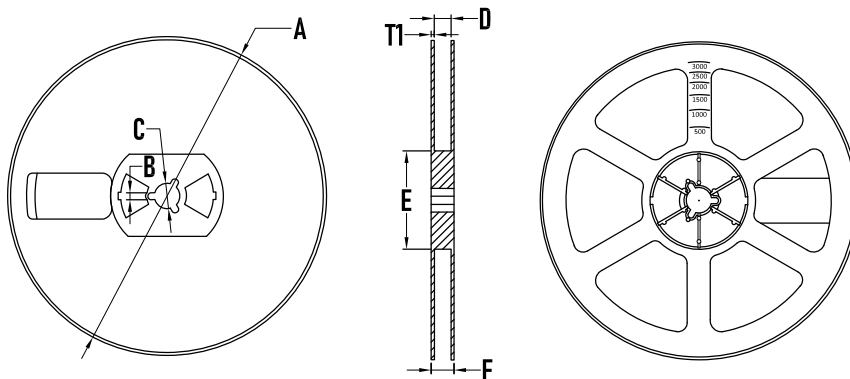

SYMBOL	MILLIMETER
A	177.8±0.2
B	2.7±0.2
C	13.5±0.2
D	9.6±0.3
E	54.5±0.2
F	12.3±0.3
T1	1.0±0.2
Quantity	5000PCS



## X-ON Electronics

Largest Supplier of Electrical and Electronic Components

*Click to view similar products for [ESD Suppressors / TVS Diodes](#) category:*

*Click to view products by [Bourne](#) manufacturer:*

Other Similar products are found below :

[60KS200C](#) [D18V0L1B2LP-7B](#) [D5V0F4U5P5-7](#) [NTE4902](#) [P4KE27CA](#) [P6KE11CA](#) [P6KE8.2A](#) [SA60CA](#) [SA64CA](#) [SMBJ12CATR](#)  
[SMBJ33CATR](#) [SMBJ6.5A](#) [SMBJ8.0A](#) [ESD101-B1-02ELS E6327](#) [ESD112-B1-02EL E6327](#) [ESD7451N2T5G](#) [19180-510](#) [CPDT-5V0USP-](#)  
[HF](#) [3.0SMCJ33CA-F](#) [3.0SMCJ36A-F](#) [HSPC16701B02TP](#) [JANTX1N6126A](#) [D3V3Q1B2DLP3-7](#) [D55V0M1B2WS-7](#) [SCM1293A-04SO](#)  
[ESD200-B1-CSP0201 E6327](#) [SM12-7](#) [CEN955 W/DATA](#) [VESD12A1A-HD1-GS08](#) [CPDQC5V0-HF](#) [D1213A-01LP4-7B](#) [ESD101-B1-02EL](#)  
[E6327](#) [AOZ8808DI-03](#) [5KP15A](#) [5KP48A](#) [5KP90A](#) [ESD3V3D7-TP](#) [15KPA36A-LF](#) [P4KE56CA](#) [P4KE68A](#) [P4KE91CATR](#) [P6KE120A](#)  
[P6KE13CA](#) [P6KE43CA](#) [P6KE6.8CA](#) [P6KE8.2](#) [P6SMBJ20CA](#) [JANTX1N6072A](#) [SR2835ESKG](#) [SA90CA](#)