

»Features

- 500Watts peak pulse power (tp = 8/20μs)
- Protects two line pairs
- Low clamping voltage
- Low leakage current
- Low capacitance (Cj=3 pF)
- Protects Up To Four Line Pairs
- IEC 61000-4-2 ±25kV contact ±25kV air
- IEC 61000-4-4 (EFT) 40A (5/50ns)
- IEC 61000-4-5 (Lightning) 30A (8/20μs)



»Applications

- 10/100 Ethernet
- Integrated magnetics/RJ-45 connectors
- LAN/WAN Equipment
- Security Cameras
- Industrial Controls
- Peripherals
- Notebooks & Desktop Computers

»Mechanical Data

- SOP8 package
- Molding compound flammability rating: UL 94V-0
- Packaging: Tape and Reel
- RoHS/WEEE Compliant

»Schematic & PIN Configuration

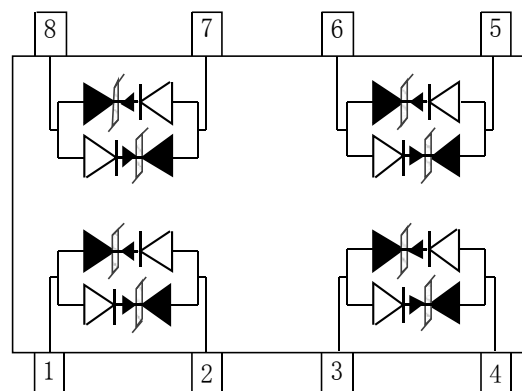

SOP8

»Absolute Maximum Rating

Rating	Symbol	Value	Units
Peak Pulse Power ($t_p = 8/20\mu s$)	P_{PP}	500	Watts
Peak Pulse Current ($t_p = 8/20\mu s$) (note1)	I_{pp}	30	A
ESD per IEC 61000-4-2 (Air) ESD per IEC 61000-4-2 (Contact)	V_{ESD}	25 25	kV
Lead Soldering Temperature	T_L	260(10seconds)	°C
Junction Temperature	T_J	-55 to + 125	°C
Storage Temperature	T_{stg}	-55 to + 125	°C

»Electrical Characteristics

Parameter	Symbol	Conditions	Min	Typical	Max	Units
Reverse Stand-Off Voltage	V_{RWM}				2.8	V
Reverse Breakdown Voltage	V_{BR}	$I_T = 1mA$	3.5			V
Reverse Leakage Current	I_R	$V_{RWM} = 2.8V, T = 25^\circ C$		50	500	nA
Clamping Voltage	V_C	$I_{PP} = 5A, t_p = 8/20\mu s$			10	V
	V_C	$I_{PP} = 30A, t_p = 8/20\mu s$		15	20	V
Junction Capacitance	C_j	$V_R = 0V, f = 1MHz$ Each line		5.0	6.0	pF

»Electrical Parameters (TA = 25°C unless otherwise noted)

Symbol	Parameter
I_{PP}	Maximum Reverse Peak Pulse Current
V_C	Clamping Voltage @ I_{PP}
V_{RWM}	Working Peak Reverse Voltage
I_R	Maximum Reverse Leakage Current @ V_{RWM}
V_{BR}	Breakdown Voltage @ I_T
I_T	Test Current

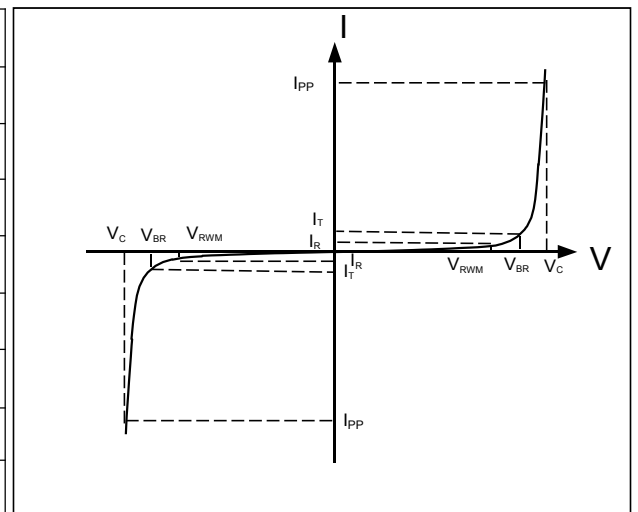

Note: 8/20μs pulse waveform.

»Typical Characteristics

Figure 1: Peak Pulse Power vs. Pulse Time

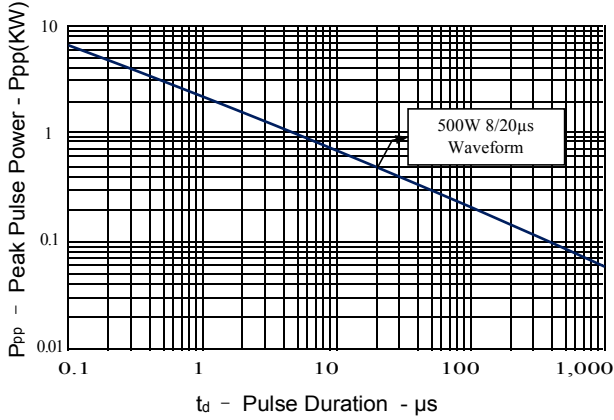

Figure 2: Power Derating Curve

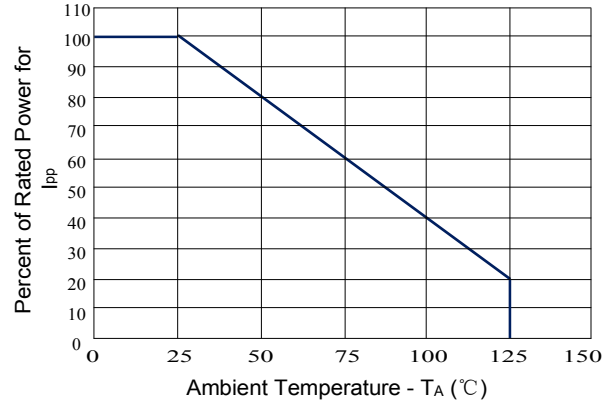

Figure3: Pulse Waveform

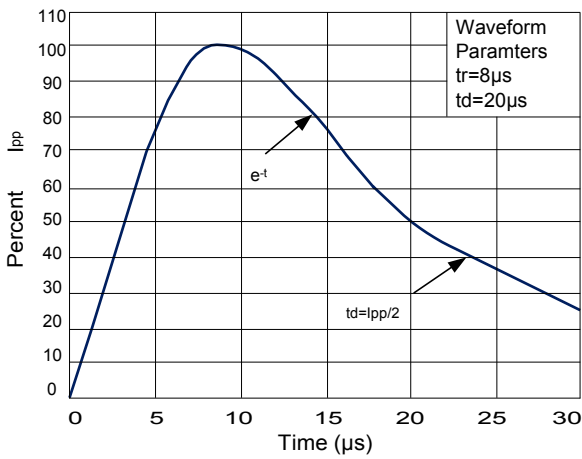

Figure 4: Clamping Voltage vs. Peak Pulse Current

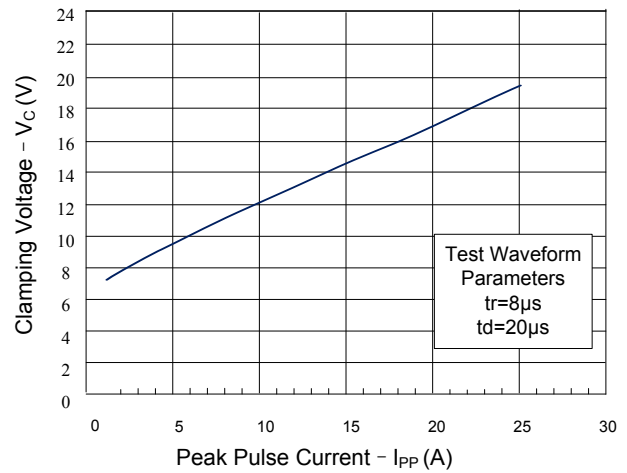

Fig.5 Eye Diagram - HDMI mask at 5.0Gbps per channel

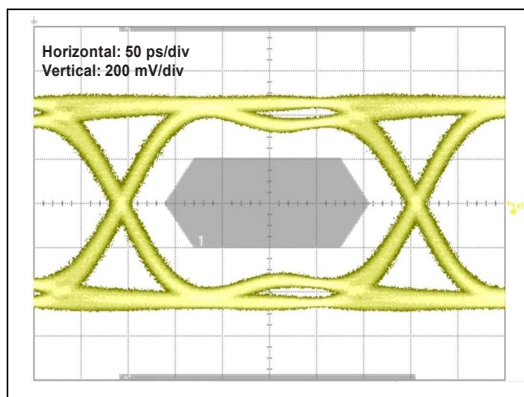
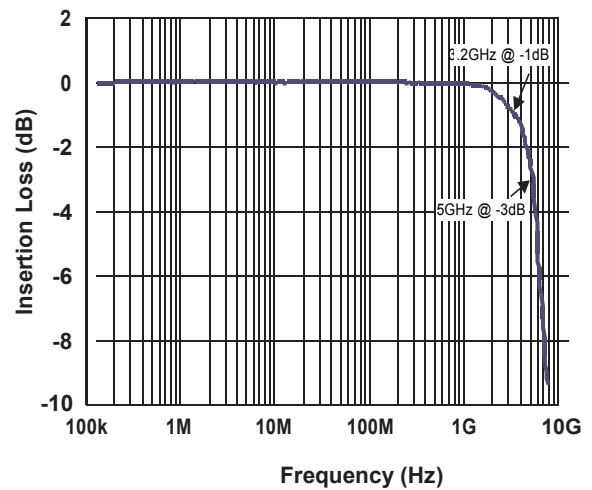

Fig.6 Insertion Loss S21



»Application Information

Device Connection for Protection of Eight Data Lines

Electronic equipment is susceptible to transient disturbances from a variety of sources including: ESD to an open connector or interface, direct or nearby lightning strikes to cables and wires, and charged cables “hot plugged” into I/O ports. The BSLVU2.8-8 is designed to protect sensitive components from damage and latch-up which may result from such transient events. The BSLVU2.8-8 can be configured to protect four high-speed line pairs differentially, or four lines to ground (common mode). The device is connected as follows:

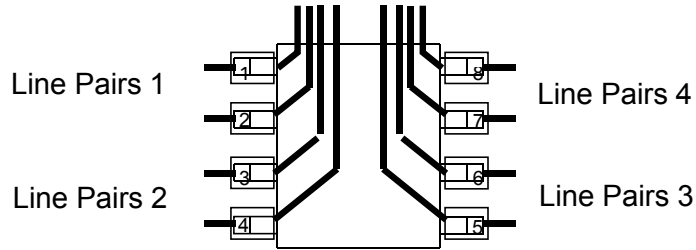

Differential Protection of Four Line Pairs

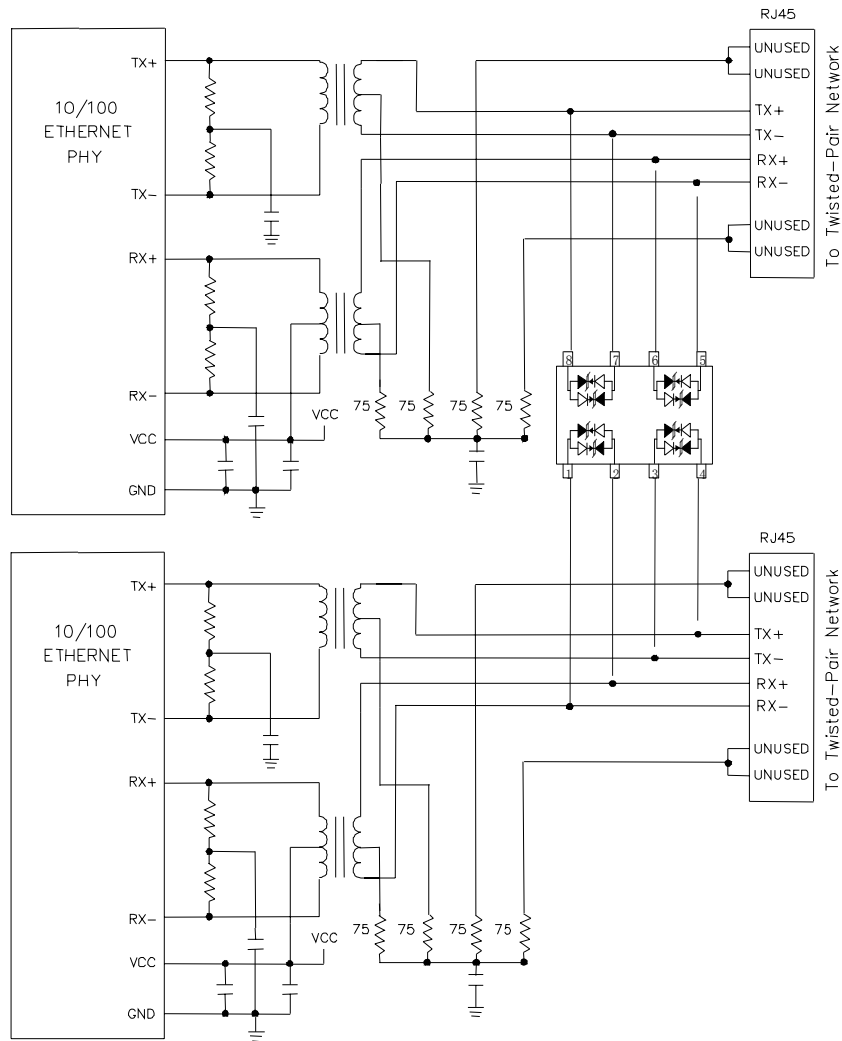

One BSLVU2.8-8 Protecting Two 10/100 Ethernet Port

»Outline Drawing – SO8

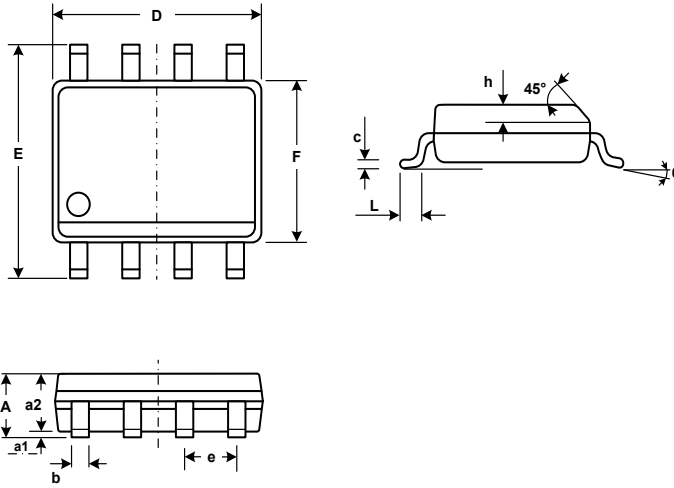

DIMENSIONS				
SYMBOL	INCHES		MILIMETER	
	MIN	MAX	MIN	MAX
A	0.053	0.069	1.35	1.75
a1	0.004	0.010	0.10	0.25
a2	0.049	0.065	1.25	1.65
D	0.189	0.197	4.80	5.00
F	0.150	0.157	3.80	4.00
E	0.236BSC		6.00BSC	
b	0.012	0.020	0.31	0.51
e	0.050BSC		1.27BSC	
h	0.010	0.020	0.25	0.50
c	0.007	0.010	0.17	0.25
L	0.016	0.041	0.40	1.04
θ	0°	8°	0°	8°

»Marking

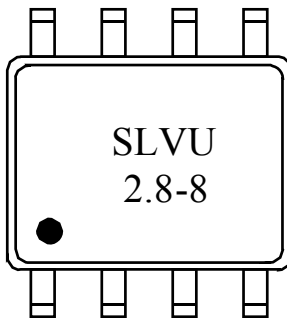

»Ordering information

Order code	Package	Base qty	Delivery mode
BSLVU2.8-8	SOP8	2500	Tape and reel

X-ON Electronics

Largest Supplier of Electrical and Electronic Components

Click to view similar products for [ESD Suppressors / TVS Diodes](#) category:

Click to view products by [Bourne](#) manufacturer:

Other Similar products are found below :

[60KS200C](#) [D18V0L1B2LP-7B](#) [D5V0F4U5P5-7](#) [NTE4902](#) [P4KE27CA](#) [P6KE11CA](#) [P6KE8.2A](#) [SA60CA](#) [SA64CA](#) [SMBJ12CATR](#)
[SMBJ33CATR](#) [SMBJ6.5A](#) [SMBJ8.0A](#) [ESD101-B1-02ELS E6327](#) [ESD112-B1-02EL E6327](#) [ESD7451N2T5G](#) [19180-510](#) [CPDT-5V0USP-](#)
[HF](#) [3.0SMCJ33CA-F](#) [3.0SMCJ36A-F](#) [HSPC16701B02TP](#) [JANTX1N6126A](#) [D3V3Q1B2DLP3-7](#) [D55V0M1B2WS-7](#) [SCM1293A-04SO](#)
[ESD200-B1-CSP0201 E6327](#) [SM12-7](#) [CEN955 W/DATA](#) [VESD12A1A-HD1-GS08](#) [CPDQC5V0-HF](#) [D1213A-01LP4-7B](#) [ESD101-B1-02EL](#)
[E6327](#) [AOZ8808DI-03](#) [5KP15A](#) [5KP48A](#) [5KP90A](#) [ESD3V3D7-TP](#) [15KPA36A-LF](#) [P4KE56CA](#) [P4KE68A](#) [P4KE91CATR](#) [P6KE120A](#)
[P6KE13CA](#) [P6KE43CA](#) [P6KE6.8CA](#) [P6KE8.2](#) [P6SMBJ20CA](#) [JANTX1N6072A](#) [SR2835ESKG](#) [SA90CA](#)