

### »Features

- 230Watts peak pulse power ( $t_p = 8/20\mu s$ )
- Tiny SOD323 package
- Bidirectional configurations
- Solid-state silicon-avalanche technology
- Low clamping voltage
- Low leakage current
- Low capacitance ( $C_j = 1.4pF$  typ.)
- Protection one data/power line
- IEC 61000-4-2  $\pm 30V$  contact  $\pm 30kV$  air
- 1.2/50 $\mu s$  12ohm 2kV (GbE PHY side)
- 10/700 $\mu s$  40ohm 4kV (GbE PHY side)

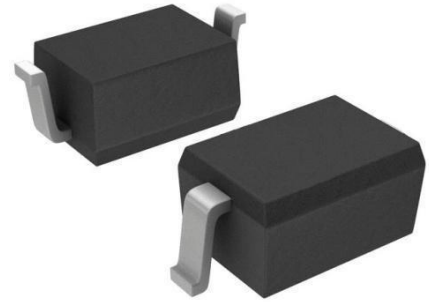

### »Applications

- 10/100/1000Ethernet
- Integated Magnetics/RJ45Connectors
- LAN/WAN Equipment
- Notebooks, Desktops, and Servers
- Portable Instrumentation

### »Mechanical Data

- SOD323 package
- Molding compound flammability rating: UL 94V-0
- Packaging: Tape and Reel
- RoHS/WEEE Compliant

### »Schematic & PINConfiguration

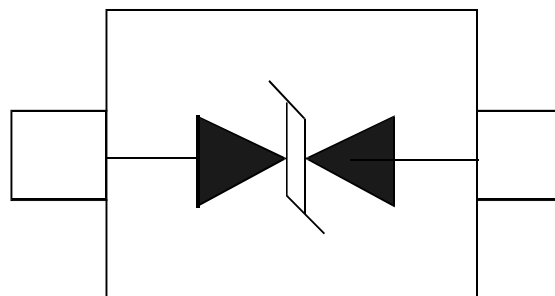

SOD-323

»Absolute Maximum Rating

Rating	Symbol	Value	Units
Peak Pulse Power ( $t_p=8/20\mu s$ )	$P_{PP}$	230	Watts
Peak Pulse Current ( $t_p=8/20\mu s$ )(note1)	$I_{pp}$	14	A
ESD per IEC 61000-4-2 (Air) ESD per IEC 61000-4-2(Contact)	$V_{ESD}$	30 30	kV
Lead Soldering Temperature	$T_L$	260(10seconds)	$^{\circ}C$
Junction Temperature	$T_J$	-55 to +125	$^{\circ}C$
Storage Temperature	$T_{stg}$	-55 to +125	$^{\circ}C$

»Electrical Characteristics

Parameter	Symbol	Conditions	Min	Typical	Max	Units
Reverse Stand-Off Voltage	$V_{RWM}$				3.3	V
Reverse Breakdown Voltage	$V_{BR}$	$I_T=1mA$	5.0	7.8		V
Reverse Leakage Current	$I_R$	$V_{RWM}=3.3V, T=25^{\circ}C$			0.2	$\mu A$
Clamping Voltage	$V_C$	$I_{PP}=7A, t_p=8/20V$			13	V
Clamping Voltage	$V_C$	$I_{PP}=14A, t_p=8/20\mu s$			17	V
Junction Capacitance	$C_j$	$V_R = 0V, f = 1MHz$		1.4	1.6	pF

»Electrical Parameters (TA = 25°C unless otherwise noted)

Symbol	Parameter
$I_{PP}$	Maximum Reverse Peak Pulse Current
$V_C$	Clamping Voltage @ $I_{PP}$
$V_{RWM}$	Working Peak Reverse Voltage
$I_R$	Maximum Reverse Leakage Current @ $V_{RWM}$
$V_T$	Trigger Voltage @ $I_T$
$I_T$	Test Current

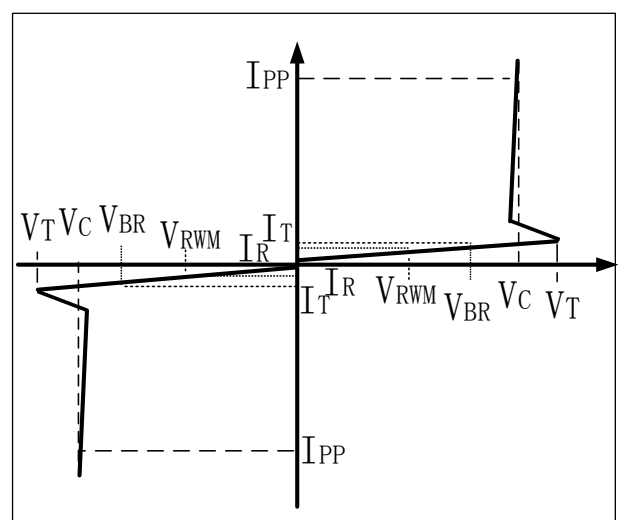

Note: 8/20 $\mu s$  pulse waveform.

»Typical Characteristics

**Figure 1: Peak Pulse Power vs. Pulse Time**

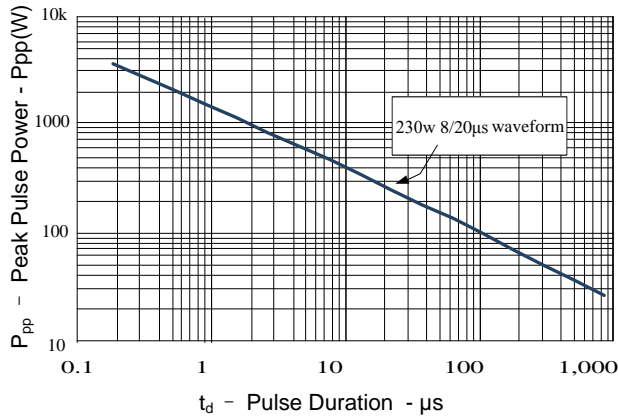

**Figure 2: Power Derating Curve**

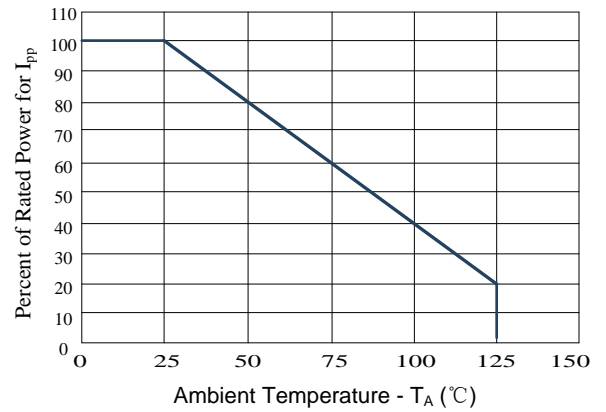

**Figure3: Pulse Waveform**

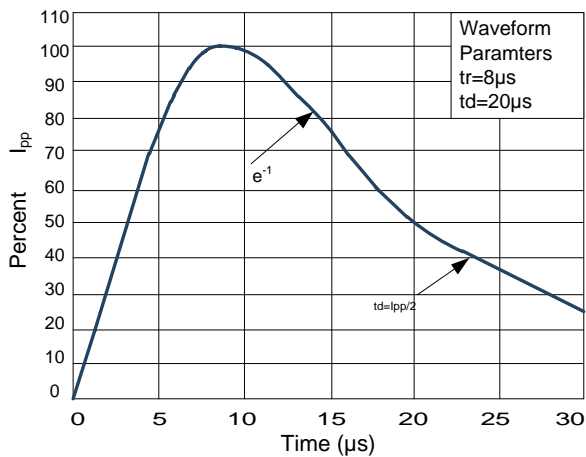

**Figure 4: Clamping Voltage vs. Ipp**

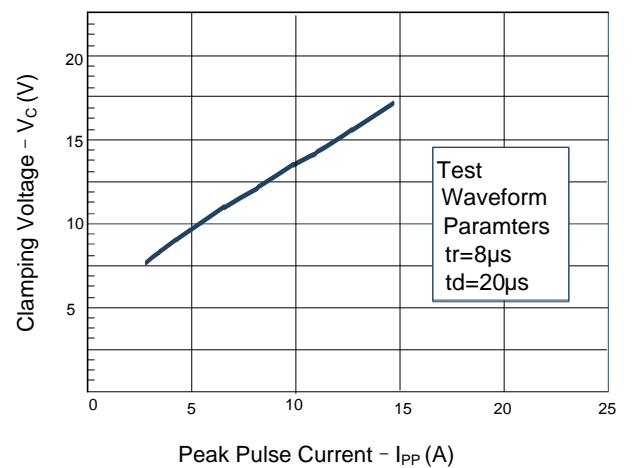

## »Lightning Surge Test Results for Gigabit Ethernet

During the metallic (line-to-line) surge test, the line being stressed is tied to the surge generator with the remaining lines tied together and connected to the generator ground. Current will flow through the line transformer transferring energy to the PHY side of the transformer. Figure 5 shows the test set-up for measuring the clamping voltage of the device. This set up is designed to test the surge in an actual gigabit Ethernet (GbE) circuit. Two 4.7 Ohm resistors is used for decoupling. The clamping voltage of the BSP4020-01FTG-C for a metallic mode 4KV (10/ 700µs) surge. The clamping voltage, measured at less than 13 volts, provides sufficient clamping margin to minimize electrical stress and is well below the failure voltage range of typical GbE PHY chips .

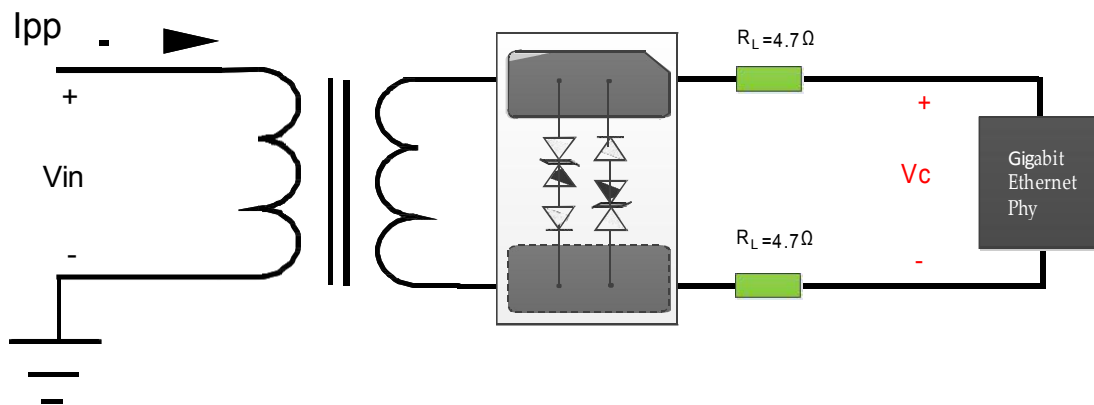

Figure 5-Clamping Voltage Test Set-Up

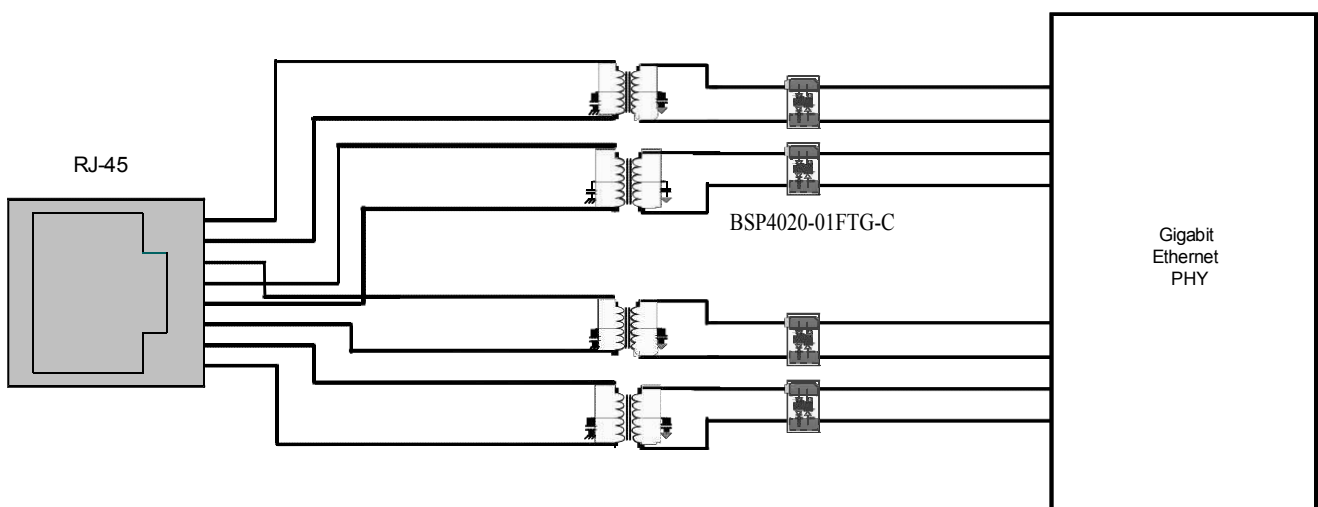
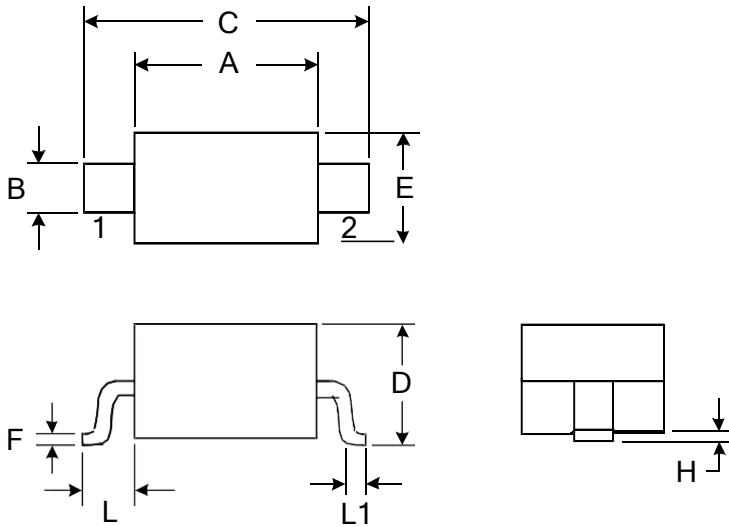

Figure 6 - GbE Protection to Lightning, ESD, and CDE

»Outline Drawing – SOD323



DIMENSIONS				
SYMBOL	MILLIMETER		INCHES	
	MIN	MAX	MIN	MAX
A	1.600	1.800	0.063	0.071
B	0.250	0.350	0.010	0.014
C	2.500	2.700	0.098	0.106
D		1.000		0.039
E	1.200	1.400	0.047	0.055
F	0.080	0.150	0.003	0.006
L	0.475 REF		0.019REF	
L1	0.250	0.400	0.010	0.016
H	0.000	0.100	0.000	0.004

**Marking**

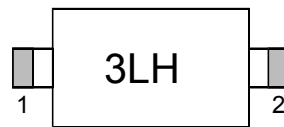

**Ordering information**

Ordercode	Package	Base qty	Deliverymode
BSP4020-01FTG-C	SOD323	3k	Tape and reel

## X-ON Electronics

Largest Supplier of Electrical and Electronic Components

*Click to view similar products for [ESD Suppressors / TVS Diodes](#) category:*

*Click to view products by [Bourne](#) manufacturer:*

Other Similar products are found below :

[60KS200C](#) [D18V0L1B2LP-7B](#) [D5V0F4U5P5-7](#) [NTE4902](#) [P4KE27CA](#) [P6KE11CA](#) [P6KE8.2A](#) [SA60CA](#) [SA64CA](#) [SMBJ12CATR](#)  
[SMBJ33CATR](#) [SMBJ6.5A](#) [SMBJ8.0A](#) [ESD101-B1-02ELS E6327](#) [ESD112-B1-02EL E6327](#) [ESD7451N2T5G](#) [19180-510](#) [CPDT-5V0USP-](#)  
[HF](#) [3.0SMCJ33CA-F](#) [3.0SMCJ36A-F](#) [HSPC16701B02TP](#) [JANTX1N6126A](#) [D3V3Q1B2DLP3-7](#) [D55V0M1B2WS-7](#) [SCM1293A-04SO](#)  
[ESD200-B1-CSP0201 E6327](#) [SM12-7](#) [CEN955 W/DATA](#) [VESD12A1A-HD1-GS08](#) [CPDQC5V0-HF](#) [D1213A-01LP4-7B](#) [ESD101-B1-02EL](#)  
[E6327](#) [AOZ8808DI-03](#) [5KP15A](#) [5KP48A](#) [5KP90A](#) [ESD3V3D7-TP](#) [15KPA36A-LF](#) [P4KE56CA](#) [P4KE68A](#) [P4KE91CATR](#) [P6KE120A](#)  
[P6KE13CA](#) [P6KE43CA](#) [P6KE6.8CA](#) [P6KE8.2](#) [P6SMBJ20CA](#) [JANTX1N6072A](#) [SR2835ESKG](#) [SA90CA](#)