

# MBR20100xx

## Schottky Barrier Rectifier

### Features

- Low forward voltage drop
- High current capability
- High forward surge capability
- Low power losses, High efficiency
- Guarding for over voltage protection

### Applications

Low VF Schottky barrier rectifier are designed for high frequency, miniature switched mode power supplies such as adapters ,lighting and on-board DC/DC conerters.

### Package

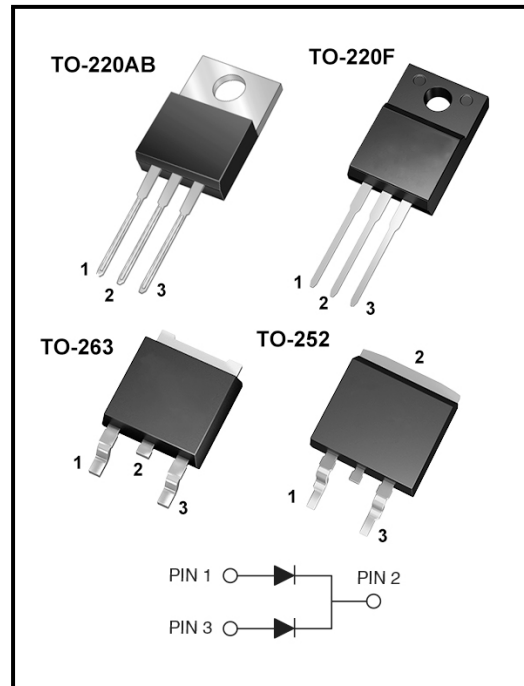

### Mechanical Data

- Molded Plastic: UL Flammability Classification Rating 94V-0
- Lead free in compliance with EU RoHS 2011/65/EU directive
- Solder bath temperature 275°C maximum, 10s per JESD 22-B106
- Case: Molded plastic
- Polarity: As marked
- Mounting Position: Any

### Ordering information

Order code	Package	Base qty	Delivery mode
MBR20100CT	TO-220AB	50pcs/tube	1000pcs/box 5000pcs/carton
MBR20100FCT	TO-220F	50pcs/tube	1000pcs/box 5000pcs/carton
MBR20100DC	TO-263	50pcs/tube	1000pcs/box 5000pcs/carton
MBR20100DC-R	TO-263	800pcs/tube	800pcs/box 4000pcs/carton
MBR20100CS	TO-252	2500pcs/tube	2500pcs/box 12500pcs/carton



# MBR20100xx

## Schottky Barrier Rectifier

### Maximum Ratings (@T<sub>A</sub>=25°C unless otherwise noted)

Symbol	Parameters	Value	Unit	
V <sub>RRM</sub>	Maximum Repetitive Peak Reverse Voltage	100	V	
V <sub>RWM</sub>	Working Peak Reverse Voltage	100	V	
V <sub>DC</sub>	Maximum DC Blocking Voltage	100	V	
I <sub>O</sub>	Maximum Average Forward Rectified Current	Per Leg	10	A
		Total	20	
I <sub>FSM</sub>	Non-repetitive Peak Forward Surge Current 8.3ms Single half-sine-wave	340	A	
R <sub>θJC</sub>	Typical Thermal Resistance <sup>1</sup>	TO-220AB,TO-263,TO-252	2	°C/W
		TO-220F	4	
T <sub>J</sub>	Operating Junction Temperature Range	150	°C	
T <sub>STG</sub>	Storage Temperature Range	-40 to +150	°C	

Note1:Thermal resistance from Junction to case per leg mounted on the sink.

### Electrical Characteristics (@T<sub>A</sub>=25°C unless otherwise noted)

Symbol	Parameters	Text Condition	Typ	Max	Unit	
V <sub>F</sub>	Forward Voltage Drop <sup>2</sup>	at I <sub>F</sub> =3A	T <sub>A</sub> = 25°C	0.63	–	V
			T <sub>A</sub> = 125°C	0.51	–	
		at I <sub>F</sub> =5A	T <sub>A</sub> = 25°C	0.69	–	
			T <sub>A</sub> = 125°C	0.56	–	
		at I <sub>F</sub> =10A	T <sub>A</sub> = 125°C	0.76	0.82	
			T <sub>A</sub> = 125°C	0.63	–	
I <sub>R</sub>	Maximum Reverse Current	V <sub>R</sub> =100V	T <sub>A</sub> = 25°C	3	10	uA
			T <sub>A</sub> = 125°C	2	–	mA

Note2:Pulsetest:300 μs pulse width,1%duty cycle



# MBR20100xx

Schottky Barrier Rectifier

Typical Performance Characteristics ( $T_J = 25^\circ\text{C}$ , unless otherwise noted)

Figure 1: Maximum Forward Current Derating Curve

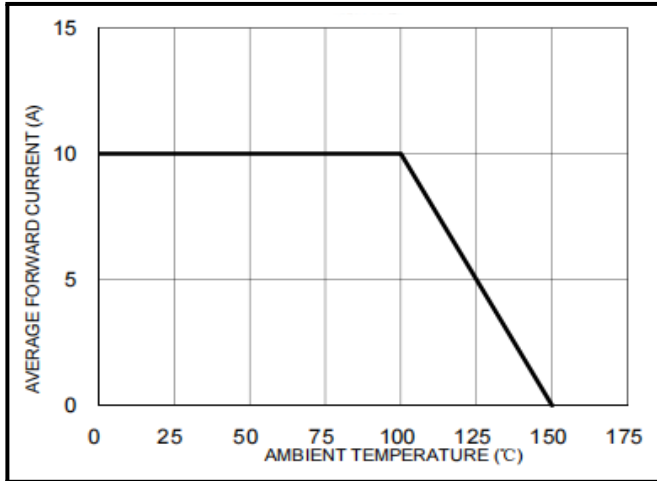

Figure 2: Maximum Non-Repetitive Forward Surge Current

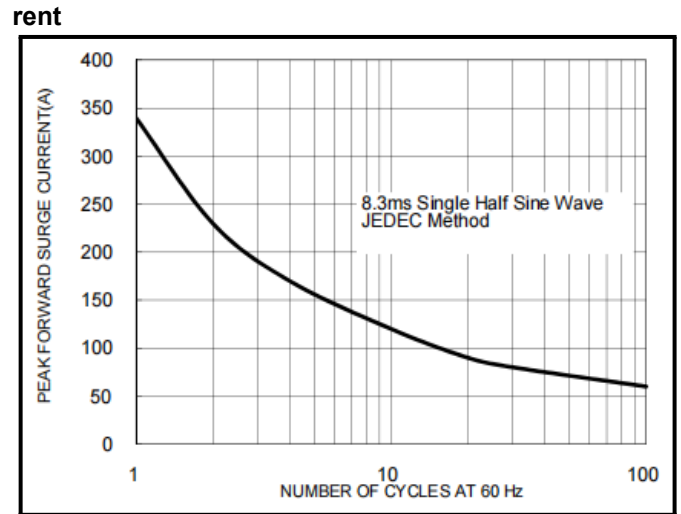

Figure 3: Typical Forward Characteristics

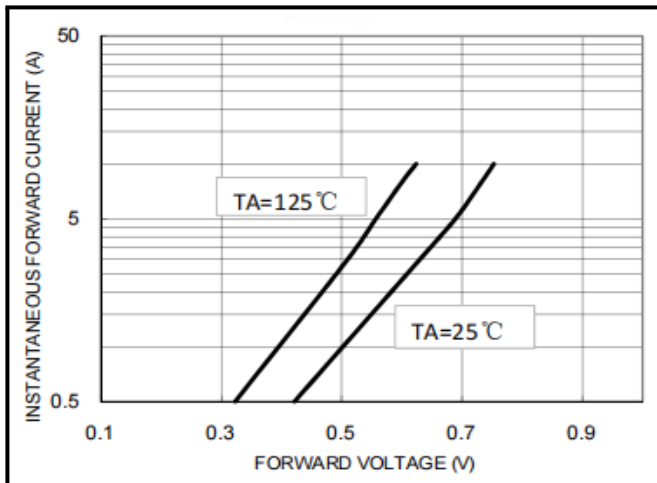
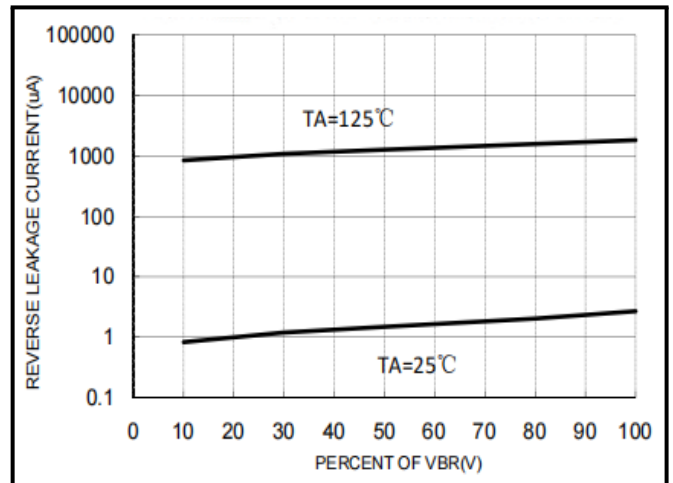

Figure 4: Typical Reverse Characteristics



# MBR20100xx

Schottky Barrier Rectifier

## Packaging Tape - TO-220AB

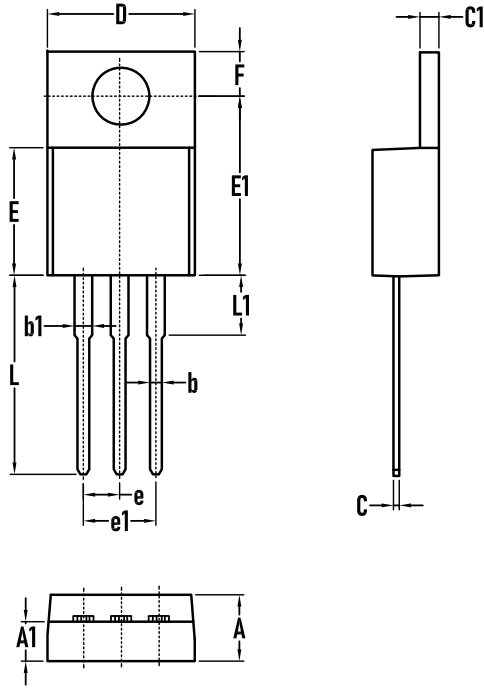

SYMBOL	MIN.	TYP.	MAX.
A	4.30	4.50	4.70
A1	2.52	2.67	2.82
b	0.71	0.81	0.91
b1	1.17	1.27	1.37
C	0.30	0.40	0.50
C1	1.17	1.27	1.37
D	9.90	10.00	10.20
E	8.50	8.70	8.90
E1	12.00	12.25	12.50
e	2.44	2.54	2.64
e1	4.88	5.08	5.26
F	2.60	2.75	2.80
L	13.00	13.50	14.00
L1	3.80	4.00	4.20

## Packaging Tape - TO-220F

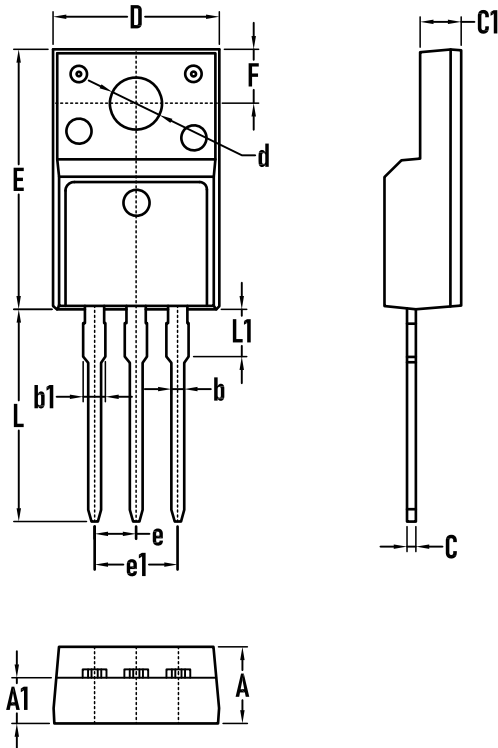

SYMBOL	MIN	TYP	MAX
A	4.30	4.60	4.80
A1	2.70	2.80	2.90
b	0.70	0.80	0.90
b1	1.20	1.30	1.40
C	0.40	0.50	0.60
C1	2.40	2.60	2.80
D	9.90	10.00	10.20
E	15.20	15.60	16.00
e	2.44	2.54	2.64
e1	4.88	5.08	5.26
F	3.00	3.30	3.60
L	12.70	13.20	13.70
L1	2.70	2.90	3.10
d	3.10	3.20	3.30



# MBR20100xx

Schottky Barrier Rectifier

Packaging Tape - TO-263

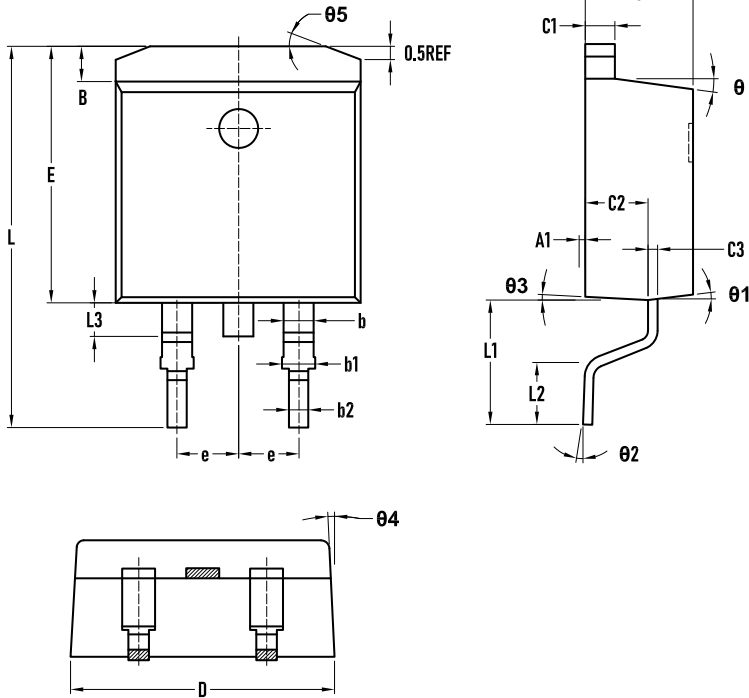

SYMBOL	MIN.	TYP.	MAX.
A1	0	—	0.25
B	1.32	1.37	1.42
b	—	1.27	—
b1	1.30	1.40	1.45
b2	—	0.81	—
C	4.52	4.57	4.62
C1	—	1.27	—
C2	2.64	2.69	2.74
C3	—	0.38	—
D	10.11	10.16	10.21
E	10.02	10.07	10.12
e	—	2.54	—0
L	14.65	14.95	15.25
L1	4.60	4.90	5.20
L2	2.25	2.45	2.65
L3	1.10	1.30	1.50
Θ	6°	7°	8°
Θ1	6°	7°	8°
Θ2	0°	—	8°
Θ3	2°	3°	4°
Θ4	2°	3°	4°
Θ5	—	—	20°



# MBR20100xx

Schottky Barrier Rectifier

Packaging Tape - TO-252

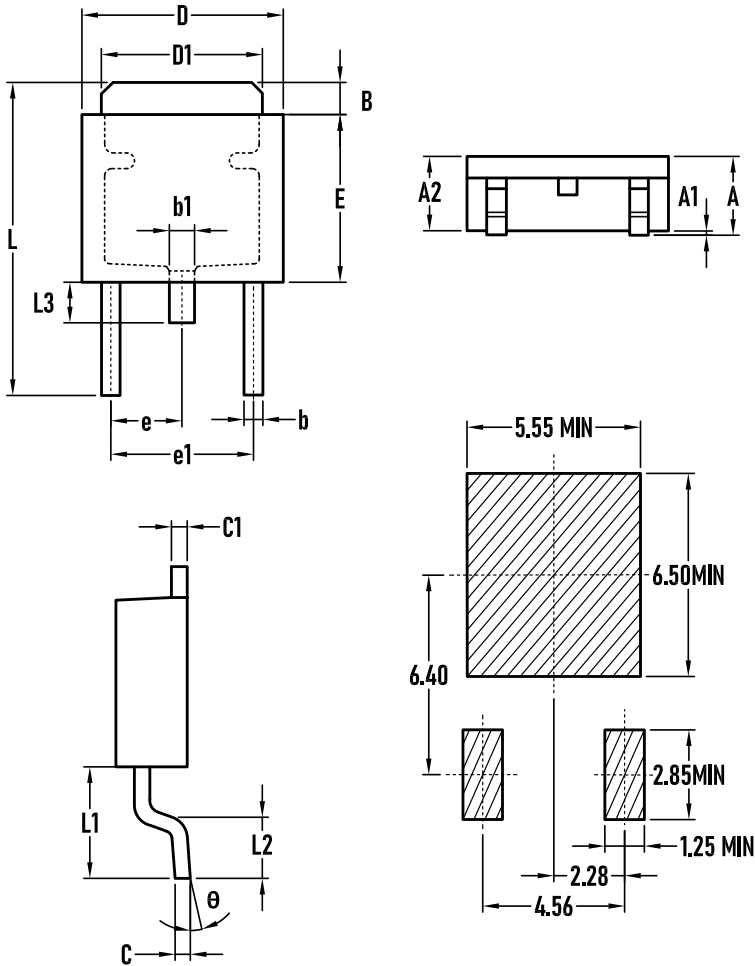

SYMBOL	MIN	TYP	MAX
A	2.20	2.35	2.50
A1	0.00	0.05	0.12
A2	2.20	2.30	2.40
B	1.20	1.40	1.60
b	0.50	0.60	0.70
b1	0.70	0.80	0.90
C	0.40	0.50	0.60
C1	0.40	0.50	0.60
D	6.35	6.50	6.65
D1	5.20	5.30	5.40
E	5.40	5.50	5.70
e	2.20	2.30	2.40
e1	4.40	4.60	4.80
L	9.60	9.90	10.20
L1	2.70	2.90	3.10
L2	1.40	1.60	1.80
L3	0.90	1.20	1.50
Θ	0°	4°	8°

