

Features

- 400 watts peak pulse power ($t_p = 8/20\mu s$)
- Protects two -7V to 12V lines
- Low capacitance
- Low clamping voltage
- Solid-state silicon avalanche technology

IEC COMPATIBILITY (EN61000-4)

- IEC 61000-4-2 (ESD) $\pm 15kV$ (air), $\pm 8kV$ (contact)
- IEC 61000-4-4 (EFT) 40A (5/50ns)

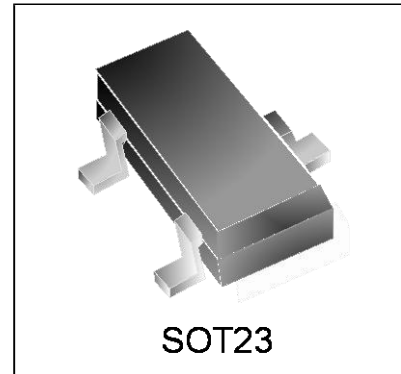

Mechanical Characteristics

- JEDEC SOT23 package
- Molding compound flammability rating: UL 94V-0
- Marking : Making Code
- Packaging : Tape and Reel per EIA 481

Applications

- Protection of RS-485 transceivers with extended common-mode range
- Security systems
- Automatic Teller Machines
- HFC systems
- Net works

Circuit Diagram

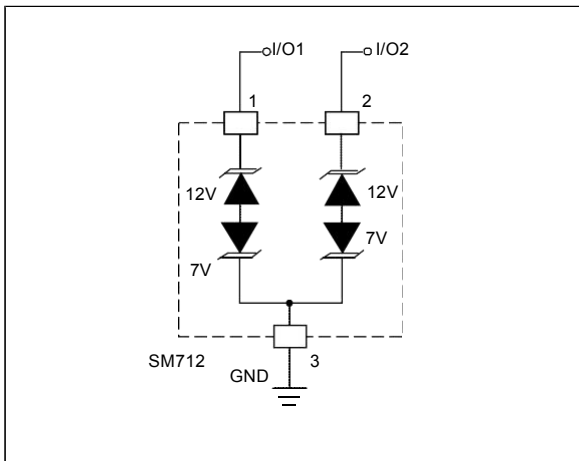

Schematic & PIN Configuration

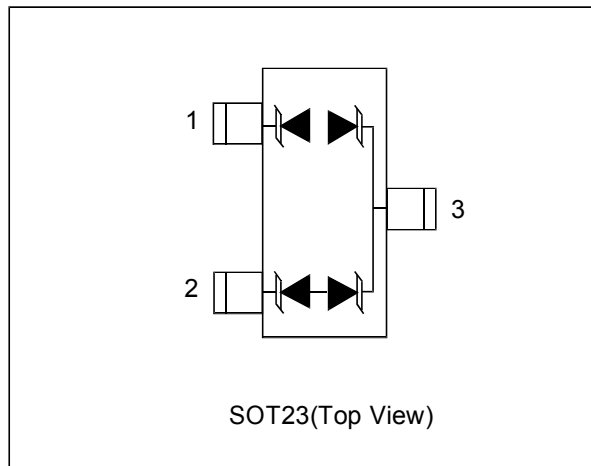

Absolute Maximum Rating

Rating	Symbol	Value	Units
Peak Pulse Power ($t_p=8/20\mu s$)	P_{PP}	400	Watts
Lead Soldering Temperature	T_L	260(10 sec.)	$^{\circ}C$
Peak Pulse Current ($t_p=8/20\mu s$)	I_{pp}	17/12	A
Operating Temperature	T_J	-55 to + 125	$^{\circ}C$
Storage Temperature	T_{STG}	-55 to +150	$^{\circ}C$

Electrical Parameters (T=25 $^{\circ}C$)

Symbol	Parameter
I_{PP}	Maximum Reverse Peak Pulse Current
V_C	Clamping Voltage @ I_{PP}
V_{RWM}	Working Peak Reverse Voltage
I_R	Maximum Reverse Leakage Current @
V_{BR}	Breakdown Voltage @ I_T
I_T	Test Current
I_F	Forward Current
V_F	Forward Voltage @ I_F

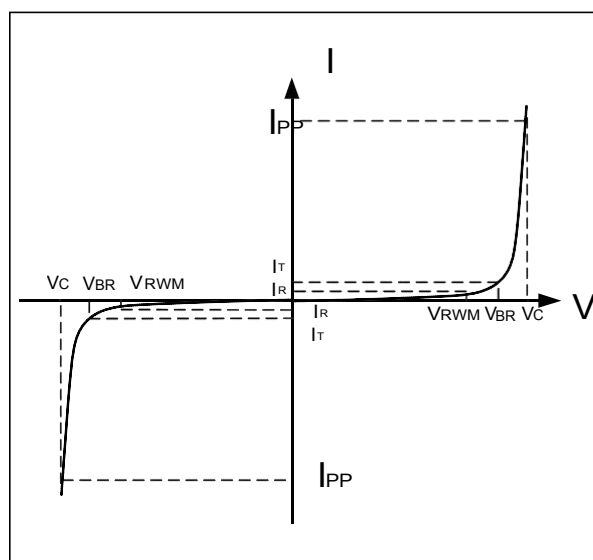
Electrical Characteristics

SM712-N									
Parameter	Symbol	Conditions	Pins 1 to 3 and 2 to 3 (12V TVS)			Pins 3 to 1 and 3 to 2 (7V TVS)			Units
			Min	Typ	Max	Min	Typ	Max	
Reverse Stand-Off Voltage	V_{RWM}	Pin 3 to 1 or Pin 2 to 1			12			7	V
Reverse Breakdown Voltage	V_{BR}	$I_{PT} = 1mA$	13.3			7.5			V
Reverse Leakage Current	I_R	$V_R = V_{RWM}$			1			20	μA
Clamping Voltage	V_C	$I_{PP} = 5A$, $t_p = 8/20\mu s$			20			12	V
Clamping Voltage	V_C	$I_{PP} = 17A$, $t_p = 8/20\mu s$			26			15	V
Junction Capacitance	C_j	$V_R = 0V$, $f = 1MHz$			75			75	pF
		$V_R = V_{RWM}$, $f = 1MHz$		45			45		pF

Typical Characteristics

Figure 1 Non-Repetitive Peak Pulse Power vs. Pulse Time

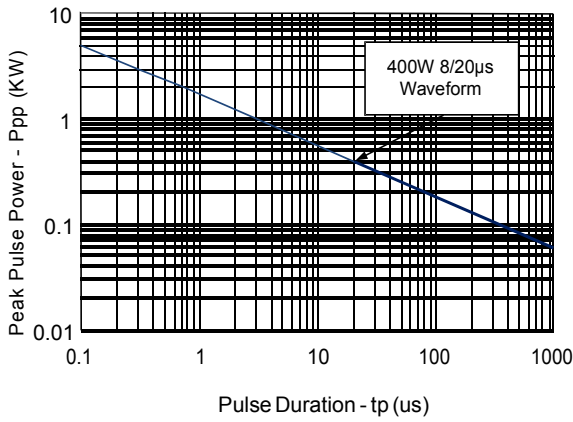

Figure 2 Power Derating curve

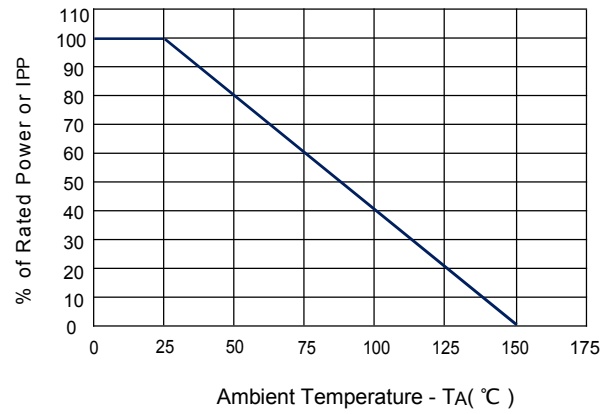

Figure 3 PulseWaveform

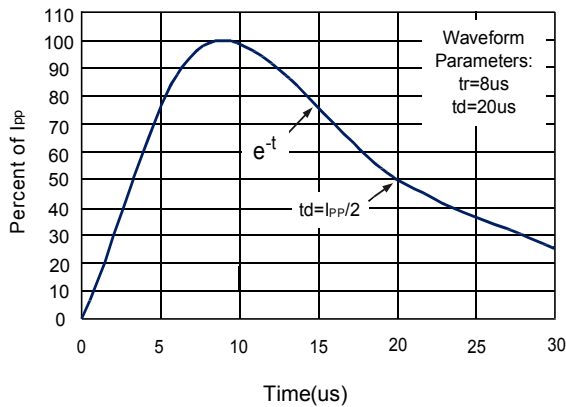

Figure 4 Clamping Voltage vs. Peak Pulse Current

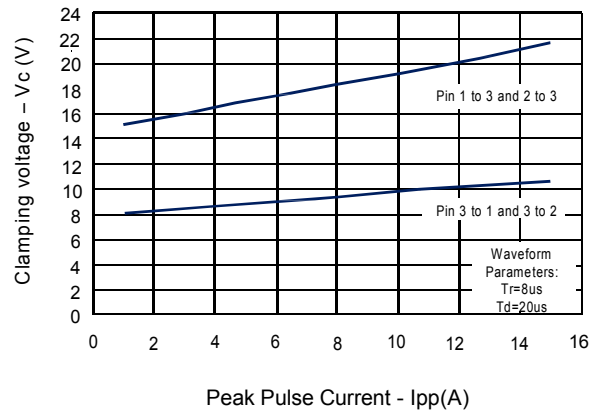
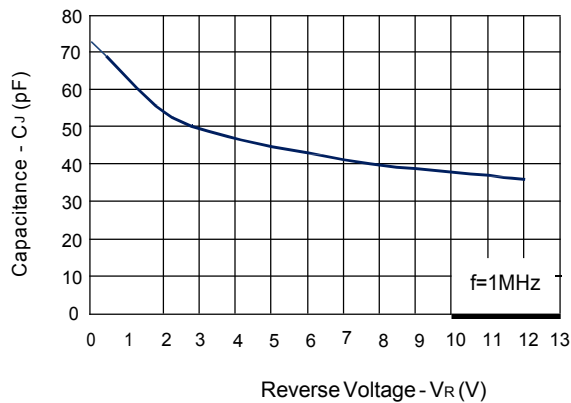

Figure 5 Capacitance vs. Reverse Voltage



Application Information

Device Connection for Protection of Two RS-485 Data Lines

EIA RS-485 specifies a $\pm 7V$ ground difference between devices on the bus. This permits the bus voltage to range from +12V (5V + 7V) to -7V (0 - 7V).

The SM712-N is designed to protect two RS-485 data lines in extended comm on mode applications. The SM712-N may be used to protect devices from transient voltages resulting from ESD, EFT, and lightning. The device is designed with asymmetrical operating voltages for optimum protection. The TVS diodes at pins 1 and 2 have a working voltage of 12 volts. These pins are connected to the differential data line pairs. The TVS diodes at pin 3 have a working voltage of 7 volts. Pin 3 is connected to ground. The internal TVS diodes of the SM712-N will protect the transceiver input from positive transient voltage spikes greater than 12V and Negative spikes greater than 7V.

A series current limiting resistor may be added in applications requiring enhanced surge immunity.

RS-485 Common Mode Voltages

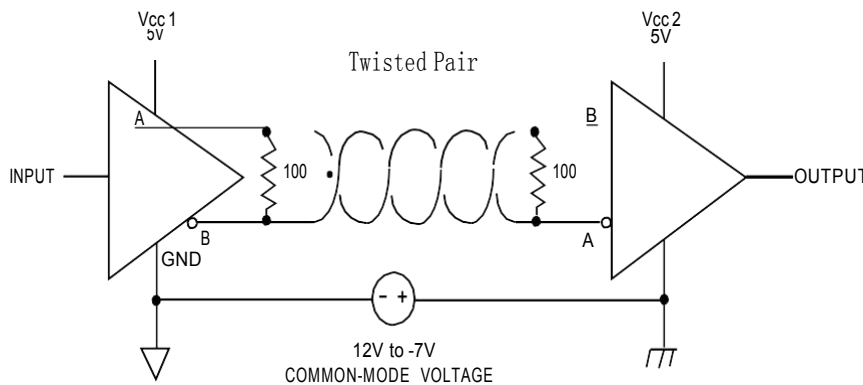

RS-485 Protection Circuit

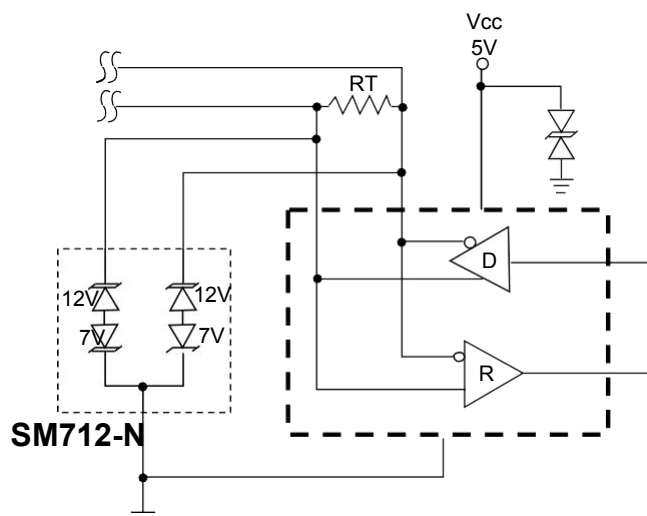

Outline Drawing – SOT23

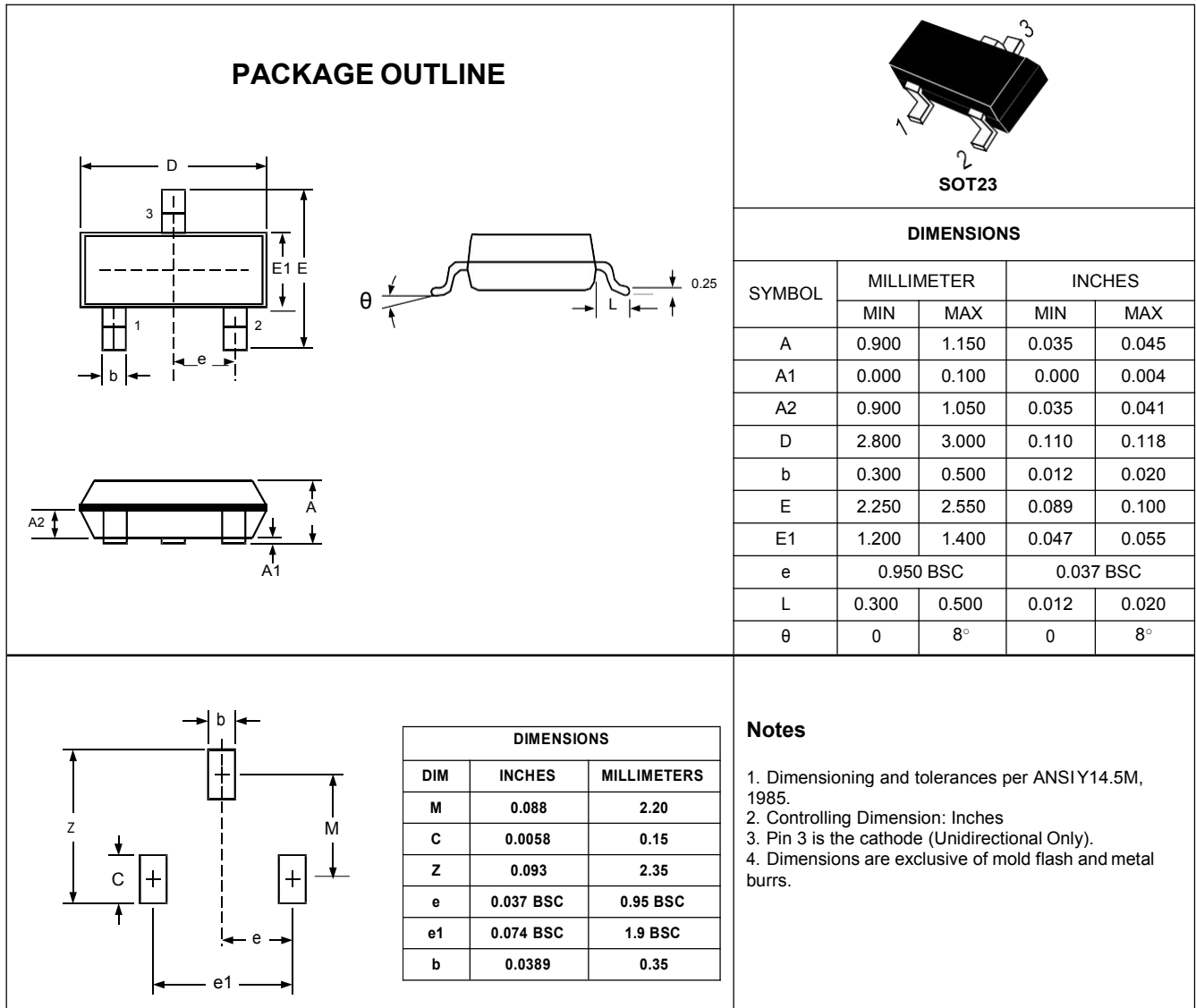

Marking Codes

Part Number	Marking Code
SM712-N	7AM

Package Information

Qty: 3k/Reel

X-ON Electronics

Largest Supplier of Electrical and Electronic Components

Click to view similar products for [ESD Suppressors / TVS Diodes](#) category:

Click to view products by [Bourne](#) manufacturer:

Other Similar products are found below :

[60KS200C](#) [D18V0L1B2LP-7B](#) [D5V0F4U5P5-7](#) [DESD5V0U1BB-7](#) [NTE4902](#) [P4KE27CA](#) [P6KE11CA](#) [P6KE39CA-TP](#) [P6KE8.2A](#)
[SA110CA](#) [SA60CA](#) [SA64CA](#) [SMBJ12CATR](#) [SMBJ33CATR](#) [SMBJ8.0A](#) [ESD101-B1-02ELS E6327](#) [ESD105-B1-02EL E6327](#) [ESD112-B1-02EL E6327](#) [ESD119B1W01005E6327XTSA1](#) [ESD5V0L1B02VH6327XTSA1](#) [ESD7451N2T5G](#) [19180-510](#) [CPDT-5V0USP-HF](#)
[3.0SMCJ33CA-F](#) [3.0SMCJ36A-F](#) [HSPC16701B02TP](#) [D3V3Q1B2DLP3-7](#) [D55V0M1B2WS-7](#) [DESD5V0U1BL-7B](#) [DRTR5V0U4SL-7](#)
[SCM1293A-04SO](#) [ESD200-B1-CSP0201 E6327](#) [SM12-7](#) [SMF8.0A-TP](#) [SMLJ45CA-TP](#) [SMQA1000T1G](#) [CEN955 W/DATA](#) [82350120560](#)
[VESD12A1A-HD1-GS08](#) [CPDUR5V0R-HF](#) [CPDQC5V0U-HF](#) [CPDQC5V0USP-HF](#) [CPDQC5V0-HF](#) [IP4042CX5/LF,135](#) [D1213A-01LP4-7B](#) [D1213A-02WL-7](#) [1SMB33CAT3G-XYZ](#) [MMAD1108/TR13](#) [5KP100A](#) [5KP15A](#)