

SMAJ / HSMAJ Series

Transient
Voltage Suppressor

Features

- Excellent clamping capability
- Low leakage current
- Low capacitance
- High surge capability
- Glass passivated chip
- Epoxy resin package
- Built-in strain relief
- Will not fatigue
- RoHS Compliant
- “H” Prefix is for Automotive applications, AEC-Q101 qualified

Package

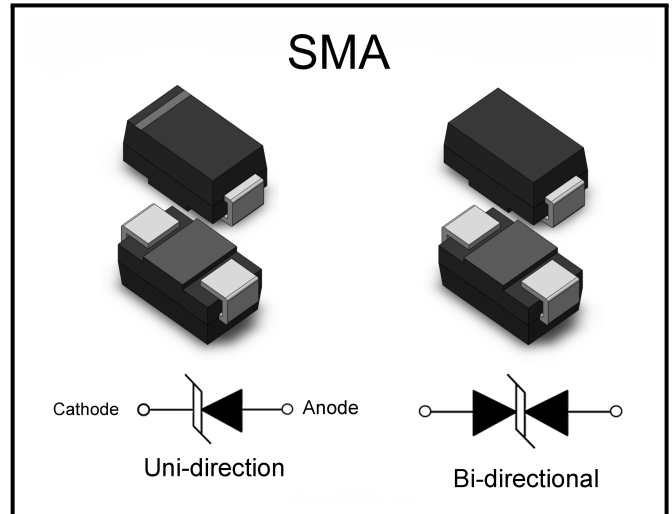

Mechanical Characteristics

- Package: SMA plastic package
- Lead Finish: Matte Tin
- Case Material: Epoxy Molding Compound
- UL Flammability Classification Rating 94V-0
- Moisture Sensitivity: Level 1 per J-STD-020

Applications

- Telecom
- Computer
- Industrial electronic
- Consumer electronic
- Automotive electronic

Making Code

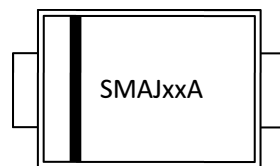

Unidirection

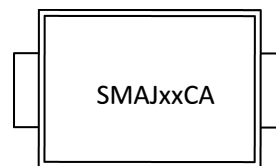

Bidirection

Summary of Packing Options

Package	Packing Description	Packing Quantity	Industry Standard
SMA	Tape/Reel, 13" reel	5000	EIA-481-1
	Tape/Reel, 7" reel	2000	EIA-481-1

**BORN SEMICONDUCTOR, INC. ALL
RIGHT RESERVED**

Specifications are subject to change without notice.

Please refer to <http://www.born-tw.com> for current information. **Revision: 2022-Jan-1-A**



Electrical Parameters

Parameter	Definition
C_J	Junction Capacitance - typical capacitance measured with 0V or V_R bias
I_{PP}	Peak Pulse Current - maximum rated peak impulse current
V_C	Clamping Voltage - Peak voltage measured across the suppressor at a specified I_{ppm}
V_{BR}	Breakdown Voltage - Maximum voltage that flows though the TVS at a specified test current (I_T)
I_R	Leakage Current - maximum peak off-state current measured at V_R
V_R	Peak Off-state Voltage - maximum voltage that can be applied while maintaining off state

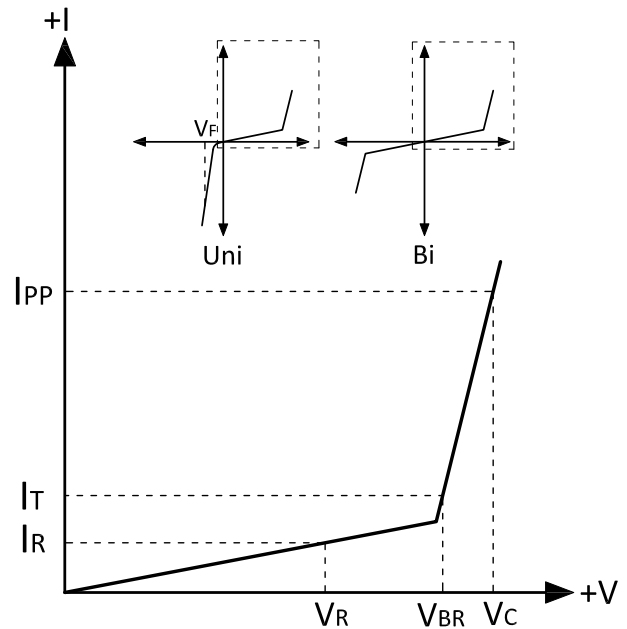

Absolute Maximum Ratings ($T_A=+25^{\circ}\text{C}$, unless otherwise noted)

Parameter	Symbol	Value	Units
Peak Pulse Power Dissipation (Note1,2)	P_{PPM}	400	W
Steady State Power Dissipation (Note3)	P_D	3.3	W
Peak Forward Surge Current (Note4)	I_{FSM}	40	A
Maximum Instantaneous Forward Voltage at 50A (Note5)	V_{FM}	3.5/6.5	V
Typical Thermal Resistance Junction to Lead	$R_{\theta JL}$	30	$^{\circ}\text{C}/\text{W}$
Typical Thermal Resistance Junction to Ambient	$R_{\theta JA}$	120	$^{\circ}\text{C}/\text{W}$
Operating Temperature Range	T_J	-55 to 150	$^{\circ}\text{C}$
Storage Temperature Range	T_{STG}	-55 to 150	$^{\circ}\text{C}$

Notes:

- (1) Non-repetitive current pulse , 10/1000us Waveform.
- (2) Mounted on copper pad area of 5×5mm to each terminal.
- (3) Infinite HeatSink at $T_A = 50^{\circ}\text{C}$
- (4) Measured on 8.3ms single half sine wave or equivalent square wave, duty cycle=4 per minute maximum.
- (5) For UnidirectionalOnly, $V_{FW} < 3.5\text{V}$ for $V_{BR} \leq 200\text{V}$ and $V_{FM} < 6.5\text{V}$ for $V_{BR} \geq 201\text{V}$.



SMAJ / H SMAJ Series

Transient
Voltage Suppressor

Electrical Characteristics ($T_A=+25^\circ\text{C}$, unless otherwise noted)

Part Number	Part Number	Reverse Stand-Off Voltage	Breakdown Voltage $V_{BR}@I_T$		Test Current I_T	Maximum Clamping Voltage $V_C @ I_{pp}$	Maximum Peak Pulse Current I_{pp}	Maximum Reverse Leakage $I_R @ V_R$
			Min.(V)	Max.(V)				
(Uni)	(Bi)	(V)			(mA)	(V)	(A)	(μA)
SMAJ5.0A H SMAJ5.0A	SMAJ5.0CA H SMAJ5.0CA	5	6.4	7	10	9.2	43.5	800
SMAJ6.0A H SMAJ6.0A	SMAJ6.0CA H SMAJ6.0CA	6	6.67	7.37	10	10.3	38.8	800
SMAJ6.5A H SMAJ6.5A	SMAJ6.5CA H SMAJ6.5CA	6.5	7.22	7.98	10	11.2	35.7	500
SMAJ6.8A H SMAJ6.8A	SMAJ6.8CA H SMAJ6.8CA	5.8	6.45	7.14	10	10.5	39.0	500
SMAJ7.0A H SMAJ7.0A	SMAJ7.0CA H SMAJ7.0CA	7	7.78	8.6	10	12	33.3	200
SMAJ7.5A H SMAJ7.5A	SMAJ7.5CA H SMAJ7.5CA	7.5	8.33	9.21	1	12.9	31	100
SMAJ8.0A H SMAJ8.0A	SMAJ8.0CA H SMAJ8.0CA	8	8.89	9.83	1	13.6	29.4	50
SMAJ8.5A H SMAJ8.5A	SMAJ8.5CA H SMAJ8.5CA	8.5	9.44	10.4	1	14.4	27.8	20
SMAJ9.0A H SMAJ9.0A	SMAJ9.0CA H SMAJ9.0CA	9	10	11.1	1	15.4	26	10
SMAJ10A H SMAJ10A	SMAJ10CA H SMAJ10CA	10	11.1	12.3	1	17	23.5	5
SMAJ11A H SMAJ11A	SMAJ11CA H SMAJ11CA	11	12.2	13.5	1	18.2	22	1
SMAJ12A H SMAJ12A	SMAJ12CA H SMAJ12CA	12	13.3	14.7	1	19.9	20.1	1
SMAJ13A H SMAJ13A	SMAJ13CA H SMAJ13CA	13	14.4	15.9	1	21.5	18.6	1
SMAJ14A H SMAJ14A	SMAJ14CA H SMAJ14CA	14	15.6	17.2	1	23.2	17.2	1
SMAJ15A H SMAJ15A	SMAJ15CA H SMAJ15CA	15	16.7	18.5	1	24.4	16.4	1



SMAJ / H SMAJ Series

Transient
Voltage Suppressor

Electrical Characteristics ($T_A=+25^\circ\text{C}$, unless otherwise noted)

Part Number	Part Number	Reverse Stand-Off Voltage	Breakdown Voltage		Test Current I_T	Maximum Clamping Voltage $V_C @ I_{pp}$	Maximum Peak Pulse Current I_{pp}	Maximum Reverse Leakage $I_R @ V_R$
			Min.(V)	Max.(V)				
(Uni)	(Bi)	(V)			(mA)	(V)	(A)	(μA)
SMAJ16A H SMAJ16A	SMAJ16CA H SMAJ16CA	16	17.8	19.7	1	26	15.4	1
SMAJ17A H SMAJ17A	SMAJ17CA H SMAJ17CA	17	18.9	20.9	1	27.6	14.5	1
SMAJ18A H SMAJ18A	SMAJ18CA H SMAJ18CA	18	20	22.1	1	29.2	13.7	1
SMAJ20A H SMAJ20A	SMAJ20CA H SMAJ20CA	20	22.2	24.5	1	32.4	12.3	1
SMAJ22A H SMAJ22A	SMAJ22CA H SMAJ22CA	22	24.4	26.9	1	35.5	11.3	1
SMAJ24A H SMAJ24A	SMAJ24CA H SMAJ24CA	24	26.7	29.5	1	38.9	10.3	1
SMAJ26A H SMAJ26A	SMAJ26CA H SMAJ26CA	26	28.9	31.9	1	42.1	9.5	1
SMAJ28A H SMAJ28A	SMAJ28CA H SMAJ28CA	28	31.1	34.4	1	45.4	8.8	1
SMAJ30A H SMAJ30A	SMAJ30CA H SMAJ30CA	30	33.3	36.8	1	48.4	8.3	1
SMAJ33A H SMAJ33A	SMAJ33CA H SMAJ33CA	33	36.7	40.6	1	53.3	7.5	1
SMAJ36A H SMAJ36A	SMAJ36CA H SMAJ36CA	36	40	44.2	1	58.1	6.9	1
SMAJ40A H SMAJ40A	SMAJ40CA H SMAJ40CA	40	44.4	49.1	1	64.5	6.2	1
SMAJ43A H SMAJ43A	SMAJ43CA H SMAJ43CA	43	47.8	52.8	1	69.4	5.8	1
SMAJ45A H SMAJ45A	SMAJ45CA H SMAJ45CA	45	50	55.3	1	72.7	5.5	1
SMAJ48A H SMAJ48A	SMAJ48CA H SMAJ48CA	48	53.3	58.9	1	77.4	5.2	1



SMAJ / H SMAJ Series

Transient
Voltage Suppressor

Electrical Characteristics ($T_A=+25^\circ\text{C}$, unless otherwise noted)

Part Number	Part Number	Reverse Stand-Off Voltage	Breakdown Voltage $V_{BR}@I_T$		Test Current I_T	Maximum Clamping Voltage $V_C @ I_{pp}$	Maximum Peak Pulse Current I_{pp}	Maximum Reverse Leakage $I_R @ V_R$
			Min.(V)	Max.(V)				
(Uni)	(Bi)	(V)			(mA)	(V)	(A)	(μA)
SMAJ51A H SMAJ51A	SMAJ51CA H SMAJ51CA	51	56.7	62.7	1	82.4	4.9	1
SMAJ54A H SMAJ54A	SMAJ54CA H SMAJ54CA	54	60	66.3	1	87.1	4.6	1
SMAJ58A H SMAJ58A	SMAJ58CA H SMAJ58CA	58	64.4	71.2	1	93.6	4.3	1
SMAJ60A H SMAJ60A	SMAJ60CA H SMAJ60CA	60	66.7	73.7	1	96.8	4.1	1
SMAJ64A H SMAJ64A	SMAJ64CA H SMAJ64CA	64	71.1	78.6	1	103	3.9	1
SMAJ70A H SMAJ70A	SMAJ70CA H SMAJ70CA	70	77.8	86	1	113	3.5	1
SMAJ75A H SMAJ75A	SMAJ75CA H SMAJ75CA	75	83.3	92.1	1	121	3.3	1
SMAJ78A H SMAJ78A	SMAJ78CA H SMAJ78CA	78	86.7	95.8	1	126	3.2	1
SMAJ85A H SMAJ85A	SMAJ85CA H SMAJ85CA	85	94.4	104	1	137	2.9	1
SMAJ90A H SMAJ90A	SMAJ90CA H SMAJ90CA	90	100	111	1	146	2.7	1
SMAJ100A H SMAJ100A	SMAJ100CA H SMAJ100CA	100	111	123	1	162	2.5	1
SMAJ110A H SMAJ110A	SMAJ110CA H SMAJ110CA	110	122	135	1	177	2.3	1
SMAJ120A H SMAJ120A	SMAJ120CA H SMAJ120CA	120	133	147	1	193	2.1	1
SMAJ130A H SMAJ130A	SMAJ130CA H SMAJ130CA	130	144	159	1	209	1.9	1
SMAJ150A H SMAJ150A	SMAJ150CA H SMAJ150CA	150	167	185	1	243	1.6	1





SMAJ / HSMAJ Series

**Transient
Voltage Suppressor**

Electrical Characteristics ($T_A=+25^\circ\text{C}$, unless otherwise noted)

Part Number	Part Number	Reverse Stand-Off Voltage	Breakdown Voltage $V_{BR}@I_T$		Test Current I_T	Maximum Clamping Voltage $V_C @ I_{pp}$	Maximum Peak Pulse Current I_{pp}	Maximum Reverse Leakage $I_R @ V_R$
			Min.(V)	Max.(V)				
(Uni)	(Bi)	(V)			(mA)	(V)	(A)	(μA)
SMAJ160A HSMAJ160A	SMAJ160CA HSMAJ160CA	160	178	197	1	259	1.5	1
SMAJ170A HSMAJ170A	SMAJ170CA HSMAJ170CA	170	189	209	1	275	1.5	1
SMAJ180A HSMAJ180A	SMAJ180CA HSMAJ180CA	180	201	222	1	292	1.4	1
SMAJ200A HSMAJ200A	SMAJ200CA HSMAJ200CA	200	224	247	1	324	1.2	1
SMAJ220A HSMAJ220A	SMAJ220CA HSMAJ220CA	220	246	272	1	356	1.1	1
SMAJ250A HSMAJ250A	SMAJ250CA HSMAJ250CA	250	279	309	1	405	1	1
SMAJ300A HSMAJ300A	SMAJ300CA HSMAJ300CA	300	335	371	1	486	0.8	1
SMAJ350A HSMAJ350A	SMAJ350CA HSMAJ350CA	350	391	432	1	567	0.7	1
SMAJ400A HSMAJ400A	SMAJ400CA HSMAJ400CA	400	447	494	1	648	0.6	1
SMAJ440A HSMAJ440A	SMAJ440CA HSMAJ440CA	440	492	543	1	713	0.6	1





SMAJ / HSMAJ Series

Transient Voltage Suppressor

Ratings and Characteristic Curves ($T_A=+25^\circ\text{C}$, unless otherwise noted)

Figure 1: Peak Pulse Power Rating

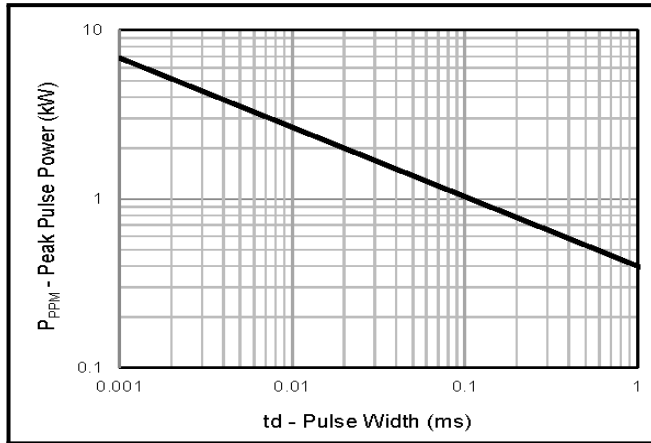

Figure 2: Pulse Derating Curve

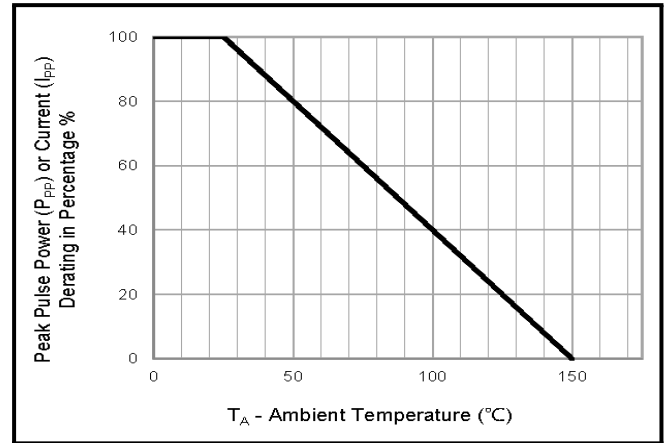

Figure 3: Pulse Waveform

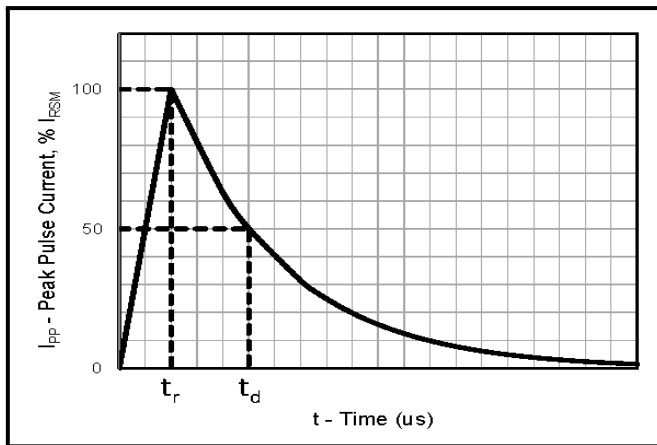

Figure 4 : Typical Junction Capacitance

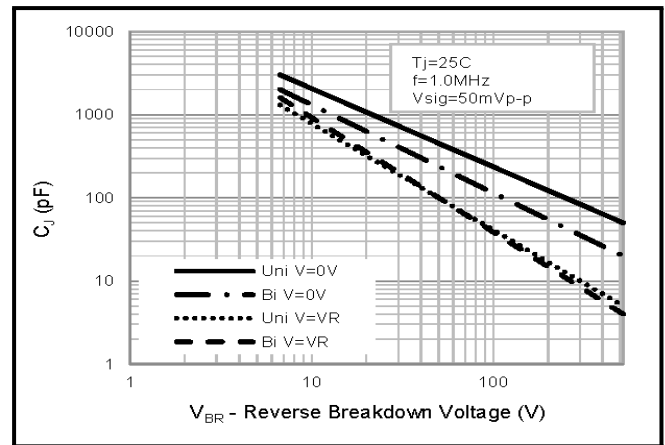

Figure 5: Steady State Power Dissipation Derating

Curve

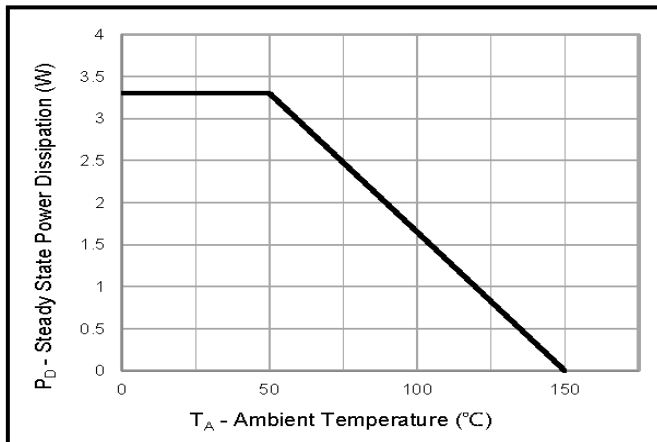
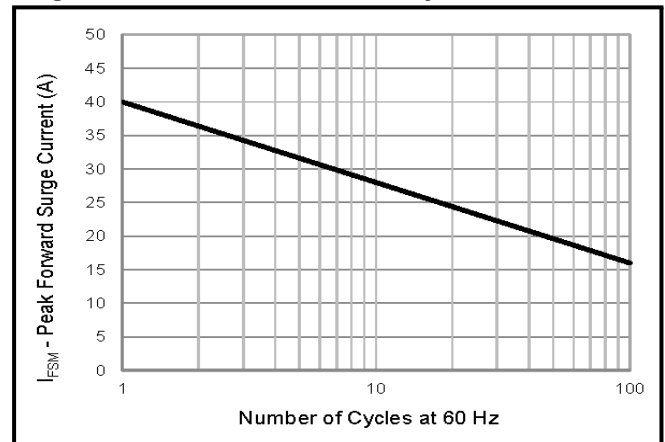
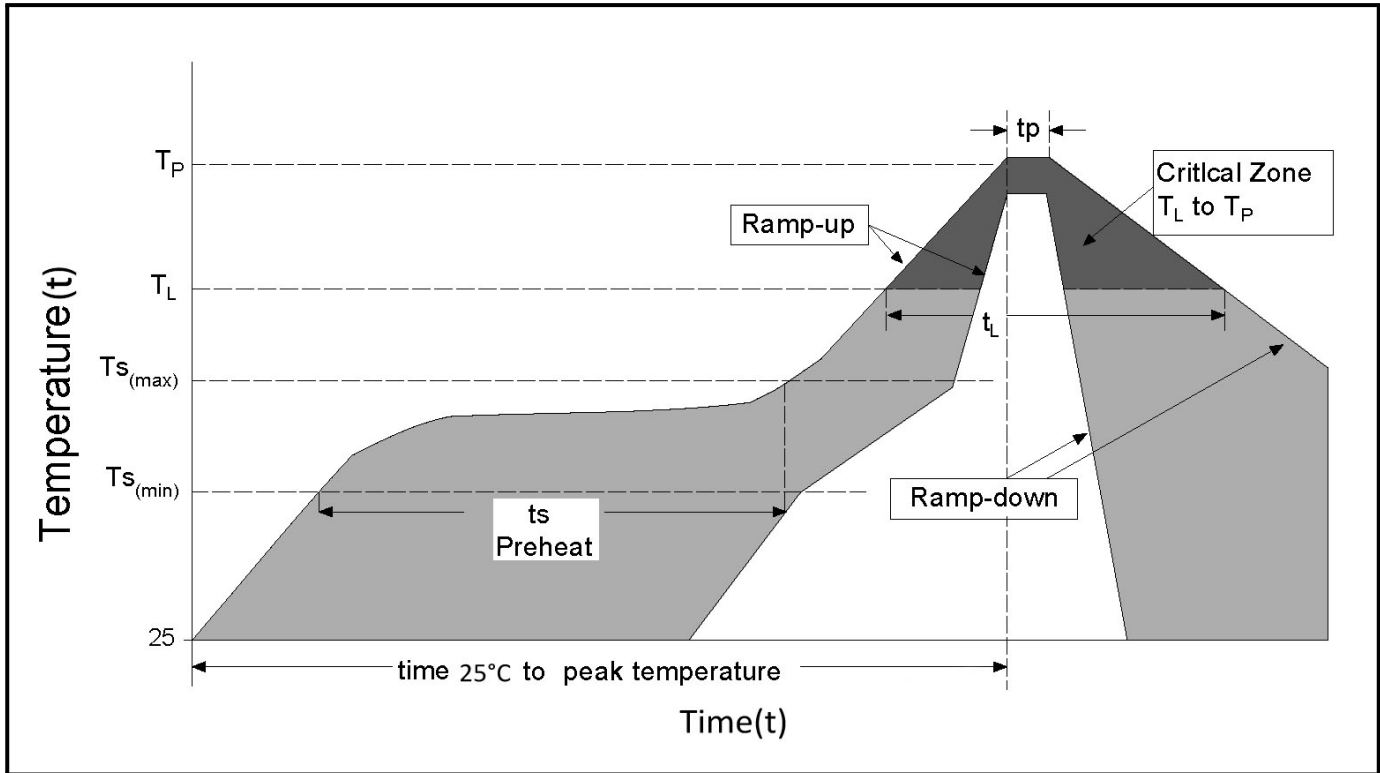

Figure 6 : Maximum Non-Repetitive Peak Forward

Surge Current Uni-Directional Only



Soldering Parameters



Reflow Condition		Lead-free assembly
Pre Heat	- Temperature Min ($T_{S(min)}$)	150°C
	- Temperature Max ($T_{S(max)}$)	200°C
	- Time (min to max) (t_s)	60 - 180 secs
Average ramp up rate (Liquidus Temp (T_L) to peak)		3°C/second max
$T_{S(max)}$ to T_L - Ramp-up Rate		3°C/second max
Reflow	- Temperature (T_L) (Liquidus)	217°C
	- Time (t_L)	60 -150 secs
Peak Temperature (T_P)		260 ^{+0/-5} °C
Time within 5°C of actual peak Temperature (t_p)		20 - 40 secs
Ramp-down Rate		6°C/second max
Time 25°C to peak Temperature (t)		8 minutes Max.
Do not exceed		260°C



SMAJ / H SMAJ Series

Transient
Voltage Suppressor

Outline Drawing - SMA

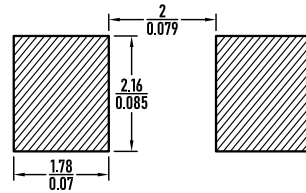
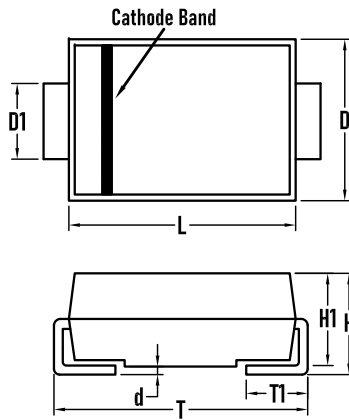

Note:
dimension : $\frac{\text{mm}}{\text{inch}}$

SYMBOL	MILLIMETER		Inches	
	MIN	MAX	MIN	MAX
D	2.5	2.7	0.098	0.106
D1	1.3	1.5	0.051	0.059
T	4.8	5.2	0.189	0.205
T1	0.9	1.5	0.035	0.060
d	-	0.2	-	0.008
H1	2.0	2.2	0.079	0.087
H	2.05	2.35	0.081	0.093
L	4.1	4.3	0.161	0.169

Packaging Tape - SMA

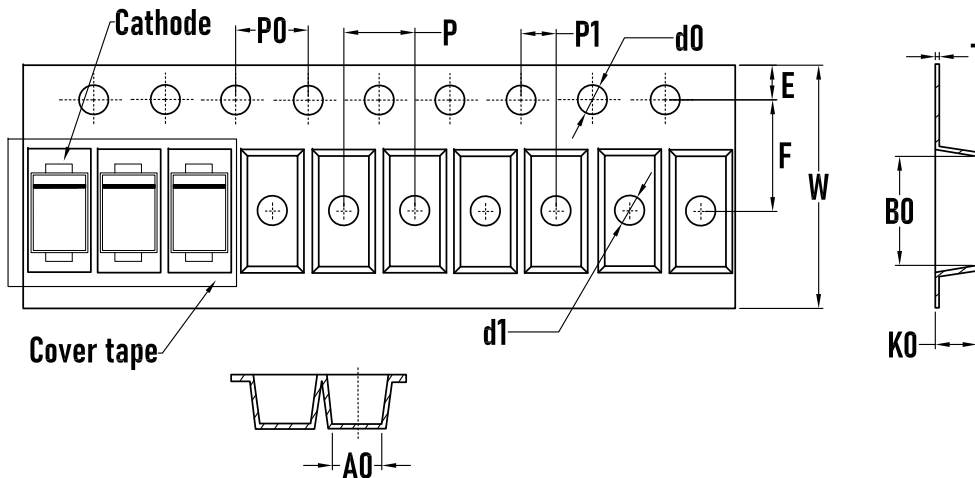

SYMBOL	MILLIMETER
A0	2.70
B0	5.10±0.1
d0	1.50±0.1
d1	1.50±0.1
E	1.75±0.1
F	5.50±0.1
K0	2.40±0.1
P	4.00±0.1
P0	4.00±0.1
P1	2.00±0.1
W	12.00±0.1
T	0.2±0.02

Packaging Reel

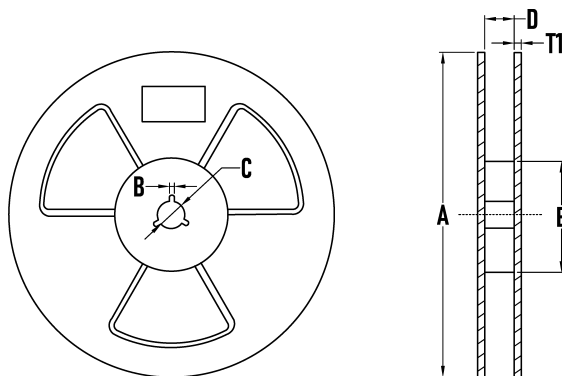

SYMBOL	MILLIMETER
A	323±2
B	3.0±0.2
C	15.0±0.5
D	13±2
E	73±2
T1	2.2±0.2
Quantity	5000PCS

