

SMFJ / HSMFJ Series

Transient
Voltage Suppressor

Features

- Excellent clamping capability
- Low leakage current
- Low capacitance
- High surge capability
- Glass passivated chip
- Epoxy resin package
- Built-in strain relief
- Will not fatigue
- RoHS Compliant
- “H” Prefix is for Automotive applications, AEC-Q101 qualified

Package

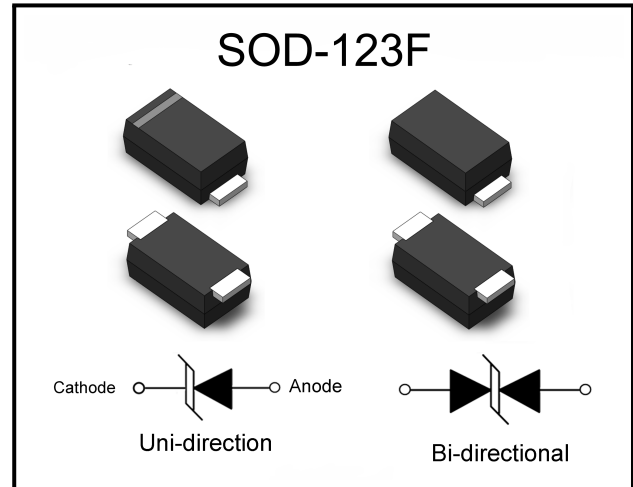

Mechanical Characteristics

- Package: SOD-123F plastic package
- Lead Finish: Matte Tin
- Case Material: Epoxy Molding Compound
- UL Flammability Classification Rating 94V-0
- Moisture Sensitivity: Level 1 per J-STD-020

Applications

- Cellular phones
- Portable devices
- Business machines
- Power supplies
- Automotive electronic

Making Code

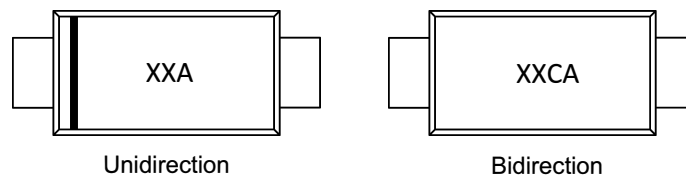

Summary of Packing Options

Package	Packing Description	Packing Quantity	Industry Standard
SOD-123F	Tape/Reel, 7" reel	3000	EIA-481-1
	Tape/Reel, 13" reel	10000	EIA-481-1



Electrical Parameters

Parameter	Definition
C_J	Junction Capacitance - typical capacitance measured with 0V or V_R bias
I_{PP}	Peak Pulse Current - maximum rated peak impulse current
V_C	Clamping Voltage - Peak voltage measured across the suppressor at a specified I_{ppm}
V_{BR}	Breakdown Voltage - Maximum voltage that flows though the TVS at a specified test current (I_T)
I_R	Leakage Current - maximum peak off-state current measured at V_R
V_R	Peak Off-state Voltage - maximum voltage that can be applied while maintaining off state

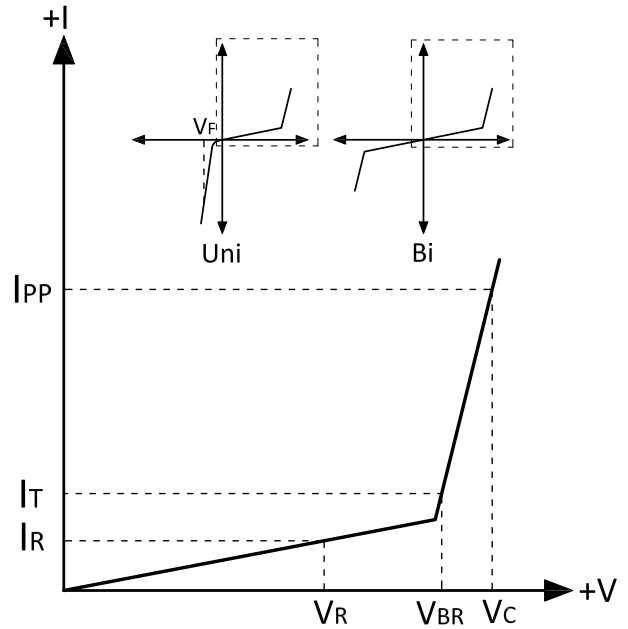

Absolute Maximum Ratings ($T_A=+25^\circ\text{C}$, unless otherwise noted)

Parameter	Symbol	Value	Units
Peak Pulse Power Dissipation(Note1,2)	P_{PPM}	200	W
Steady State Power Dissipation (Note3)	P_D	1	W
Peak Forward Surge Current (Note4)	I_{FSM}	20	A
Maximum Instantaneous Forward Voltage at 100A (Note5)	V_{FM}	3.5	V
Typical Thermal Resistance Junction to Lead	$R_{\theta JL}$	100	$^\circ\text{C/W}$
Typical Thermal Resistance Junction to Ambient	$R_{\theta JA}$	220	$^\circ\text{C/W}$
Operating Junction Temperature Range	T_J	-55 to 150	$^\circ\text{C}$
Storage Temperature Range	T_{STG}	-55 to 150	$^\circ\text{C}$

Notes:

- (1) Non-repetitive current pulse , 10/1000us Waveform.
- (2) Mounted on copper pad area of 3×3mm to each terminal.
- (3) Infinite Heat Sink at $T_A = 50^\circ\text{C}$
- (4) Measured on 8.3ms single half sine wave or equivalent square wave, duty cycle=4 perminute maximum.
- (5) For UnidirectionalOnly.



SMFJ / HSMFJ Series

**Transient
Voltage Suppressor**

Absolute Maximum Ratings ($T_A=+25^{\circ}\text{C}$, unless otherwise noted)

Part Number		Marking Code		Reverse Stand-Off Voltage V_R	Breakdown Voltage $V_{BR}@ I_T$		Test Current I_T	Maximum Clamping Voltage $V_C@ I_{PP}$	Maximum Peak Pulse Current I_{PP}	Maximum Reverse Leakage $I_R@ V_R$
					Min.(V)	Max.(V)				
(Uni)	(Bi)	(Uni)	(Bi)	(V)			(mA)	(V)	(A)	(μA)
SMFJ5.0A HSMFJ5.0A	SMFJ5.0CA HSMFJ5.0CA	5.0A	5.0CA	5	6.4	7	10	9.2	21.7	400
SMFJ6.0A HSMFJ6.0A	SMFJ6.0CA HSMFJ6.0CA	6.0A	6.0CA	6	6.67	7.37	10	10.3	19.4	400
SMFJ6.5A HSMFJ6.5A	SMFJ6.5CA HSMFJ6.5CA	6.5A	6.5CA	6.5	7.22	7.98	10	11.2	17.9	250
SMFJ7.0A HSMFJ7.0A	SMFJ7.0CA HSMFJ7.0CA	7.0A	7.0CA	7	7.78	8.6	10	12	16.7	100
SMFJ7.5A HSMFJ7.5A	SMFJ7.5CA HSMFJ7.5CA	7.5A	7.5CA	7.5	8.33	9.21	1	12.9	15.5	50
SMFJ8.0A HSMFJ8.0A	SMFJ8.0CA HSMFJ8.0CA	8.0A	8.0CA	8.0	8.89	9.83	1	13.6	14.7	25
SMFJ8.5A HSMFJ8.5A	SMFJ8.5CA HSMFJ8.5CA	8.5A	8.5CA	8.5	9.44	10.4	1	14.4	13.9	10
SMFJ9.0A HSMFJ9.0A	SMFJ9.0CA HSMFJ9.0CA	9.0A	9.0CA	9.0	10	11.1	1	15.4	13	5
SMFJ10A HSMFJ10A	SMFJ10CA HSMFJ10CA	10A	10CA	10	11.1	12.3	1	17	11.8	2.5
SMFJ11A HSMFJ11A	SMFJ11CA HSMFJ11CA	11A	11CA	11	12.2	13.5	1	18.2	11	2.5
SMFJ12A HSMFJ12A	SMFJ12CA HSMFJ12CA	12A	12CA	12	13.3	14.7	1	19.9	10.1	2.5
SMFJ13A HSMFJ13A	SMFJ13CA HSMFJ13CA	13A	13CA	13	14.4	15.9	1	21.5	9.3	1
SMFJ14A HSMFJ14A	SMFJ14CA HSMFJ14CA	14A	14CA	14	15.6	17.2	1	23.2	8.6	1
SMFJ15A HSMFJ15A	SMFJ15CA HSMFJ15CA	15A	15CA	15	16.7	18.5	1	24.4	8.2	1
SMFJ16A HSMFJ16A	SMFJ16CA HSMFJ16CA	16A	16CA	16	17.8	19.7	1	26	7.7	1
SMFJ17A HSMFJ17A	SMFJ17CA HSMFJ17CA	17A	17CA	17	18.9	20.9	1	27.6	7.2	1
SMFJ18A HSMFJ18A	SMFJ18CA HSMFJ18CA	18A	18CA	18	20	22.1	1	29.2	6.8	1
SMFJ20A HSMFJ20A	SMFJ20CA HSMFJ20CA	20A	20CA	20	22.2	24.5	1	32.4	6.2	1
SMFJ22A HSMFJ22A	SMFJ22CA HSMFJ22CA	22A	22CA	22	24.4	26.9	1	35.5	5.6	1

**BORN SEMICONDUCTOR, INC. ALL
RIGHT RESERVED**

Specifications are subject to change without notice.

Please refer to <http://www.born-tw.com> for current information. **Revision: 2022-Jan-1-A**



SMFJ / HSMFJ Series

Transient Voltage Suppressor

Absolute Maximum Ratings ($T_A=+25^\circ\text{C}$, unless otherwise noted)

Part Number		Marking Code		Reverse Stand-Off Voltage V_R	Breakdown Voltage $V_{BR}@ I_T$		Test Current I_T	Maximum Clamping Voltage $V_C@ I_{pp}$	Maximum Peak Pulse Current I_{pp}	Maximum Reverse Leakage $I_R@ V_R$
					Min.(V)	Max.(V)				
(Uni)	(Bi)	(Uni)	(Bi)	(V)	Min.(V)	Max.(V)	(mA)	(V)	(A)	(uA)
SMFJ24A HSMFJ24A	SMFJ24CA HSMFJ24CA	24A	24CA	24	26.7	29.5	1	38.9	5.1	1
SMFJ26A HSMFJ26A	SMFJ26CA HSMFJ26CA	26A	26CA	26	28.9	31.9	1	42.1	4.8	1
SMFJ28A HSMFJ28A	SMFJ28CA HSMFJ28CA	28A	28CA	28	31.1	34.4	1	45.4	4.4	1
SMFJ30A HSMFJ30A	SMFJ30CA HSMFJ30CA	30A	30CA	30	33.3	36.8	1	48.4	4.1	1
SMFJ33A HSMFJ33A	SMFJ33CA HSMFJ33CA	33A	33CA	33	36.7	40.6	1	53.3	3.8	1
SMFJ36A HSMFJ36A	SMFJ36CA HSMFJ36CA	36A	36CA	36	40	44.2	1	58.1	3.4	1
SMFJ40A HSMFJ40A	SMFJ40CA HSMFJ40CA	40A	40CA	40	44.4	49.1	1	64.5	3.1	1
SMFJ43A HSMFJ43A	SMFJ43CA HSMFJ43CA	43A	43CA	43	47.8	52.8	1	69.4	2.9	1
SMFJ45A HSMFJ45A	SMFJ45CA HSMFJ45CA	45A	45CA	45	50	55.3	1	72.7	2.8	1
SMFJ48A HSMFJ48A	SMFJ48CA HSMFJ48CA	48A	48CA	48	53.33	58.9	1	77.4	2.6	1
SMFJ51A HSMFJ51A	SMFJ51CA HSMFJ51CA	51A	51CA	51	56.7	62.7	1	82.4	2.4	1
SMFJ54A HSMFJ54A	SMFJ54CA HSMFJ54CA	54A	54CA	54	60	66.3	1	87.1	2.3	1
SMFJ58A HSMFJ58A	SMFJ58CA HSMFJ58CA	58A	58CA	58	64.4	71.2	1	93.6	2.1	1
SMFJ60A HSMFJ60A	SMFJ60CA HSMFJ60CA	60A	60CA	60	66.7	73.7	1	96.8	1.8	1
SMFJ64A HSMFJ64A	SMFJ64CA HSMFJ64CA	64A	64CA	64	71.1	78.6	1	103	1.7	1
SMFJ70A HSMFJ70A	SMFJ70CA HSMFJ70CA	70A	70CA	70	78.8	86	1	113	1.5	1
SMFJ75A HSMFJ75A	SMFJ75CA HSMFJ75CA	75A	75CA	75	83.3	92.1	1	121	1.4	1
SMFJ78A HSMFJ78A	SMFJ78CA HSMFJ78CA	78A	78CA	78	86.7	95.8	1	126	1.4	1
SMFJ85A HSMFJ85A	SMFJ85CA HSMFJ85CA	85A	85CA	85	94.4	104	1	137	1.3	1

**BORN SEMICONDUCTOR, INC. ALL
RIGHT RESERVED**

Specifications are subject to change without notice.

Please refer to <http://www.born-tw.com> for current information.

Revision: 2022-Jan-1-A



SMFJ / HSMFJ Series

Transient
Voltage Suppressor

Absolute Maximum Ratings ($T_A=+25^\circ\text{C}$, unless otherwise noted)

Part Number		Marking Code		Reverse Stand-Off Voltage V_R	Breakdown Voltage $V_{BR}@ I_T$		Test Current I_T	Maximum Clamping Voltage $V_C@ I_{PP}$	Maximum Peak Pulse Current I_{PP}	Maximum Reverse Leakage $I_R@ V_R$
SMFJ90A HSMFJ90A	SMFJ90CA HSMFJ90CA	90A	90CA	90	100	111	1	146	1.2	1
SMFJ100A HSMFJ100A	SMFJ100CA HSMFJ100CA	100A	100CA	100	111	123	1	162	1.1	1
SMFJ110A HSMFJ110A	SMFJ110CA HSMFJ110CA	110A	110CA	110	122	135	1	177	1	1
SMFJ120A HSMFJ120A	SMFJ120CA HSMFJ120CA	120A	120CA	120	133	147	1	193	0.9	1
SMFJ130A HSMFJ130A	SMFJ130CA SMFJ130CA	130A	130CA	130	144	159	1	209	0.8	1
SMFJ150A HSMFJ150A	SMFJ150CA HSMFJ150CA	150A	150CA	150	167	185	1	243	0.7	1
SMFJ160A HSMFJ160A	SMFJ160CA HSMFJ160CA	160A	160CA	160	178	197	1	259	0.7	1
SMFJ170A HSMFJ170A	SMFJ170CA HSMFJ170CA	170A	170CA	170	189	209	1	275	0.6	1
SMFJ180A HSMFJ180A	SMFJ180CA HSMFJ180CA	180A	180CA	180	201	222	1	292	0.6	1
SMFJ190A HSMFJ190A	SMFJ190CA HSMFJ190CA	190A	190CA	190	209	232	1	308	0.6	1
SMFJ200A HSMFJ200A	SMFJ200CA HSMFJ200CA	200A	200CA	200	224	247	1	324	0.6	1
SMFJ210A HSMFJ210A	SMFJ210CA HSMFJ210CA	210A	210CA	210	231	268	1	340	0.6	1
SMFJ220A HSMFJ220A	SMFJ220CA HSMFJ220CA	220A	220CA	220	246	272	1	356	0.5	1
SMFJ250A HSMFJ250A	SMFJ250CA HSMFJ250CA	250A	250CA	250	279	309	1	405	0.5	1
SMFJ300A HSMFJ300A	SMFJ300CA HSMFJ300CA	300A	300CA	300	335	371	1	486	0.4	1
SMFJ350A HSMFJ350A	SMFJ350CA HSMFJ350CA	350A	350CA	350	391	432	1	567	0.3	1
SMFJ400A HSMFJ400A	SMFJ400CA HSMFJ400CA	400A	400CA	400	447	494	1	648	0.3	1
SMFJ440A HSMFJ440A	SMFJ440CA HSMFJ440CA	440A	440CA	440	492	543	1	713	0.3	1



Ratings and Characteristic Curves ($T_A=+25^\circ\text{C}$, unless otherwise noted)

Figure 1: Peak Pulse Power Rating

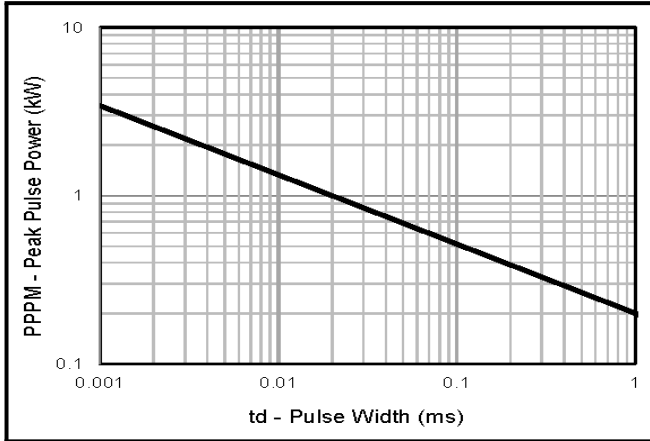

Figure 2: Pulse Derating Curve

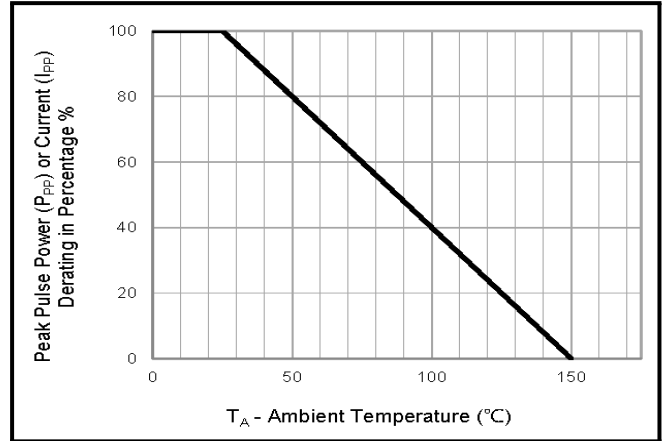

Figure 3: Pulse Waveform

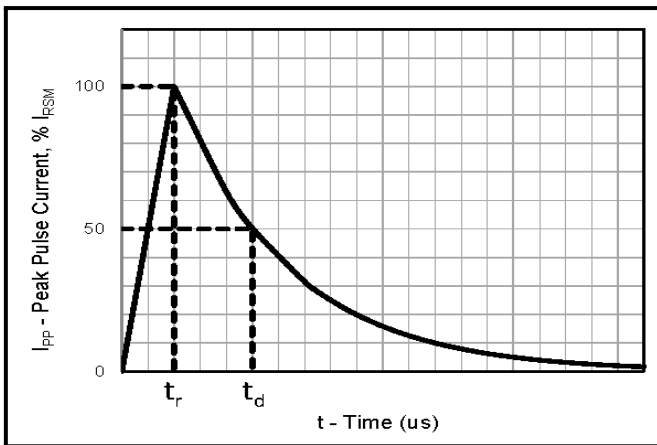

Figure 4: Typical Junction Capacitance

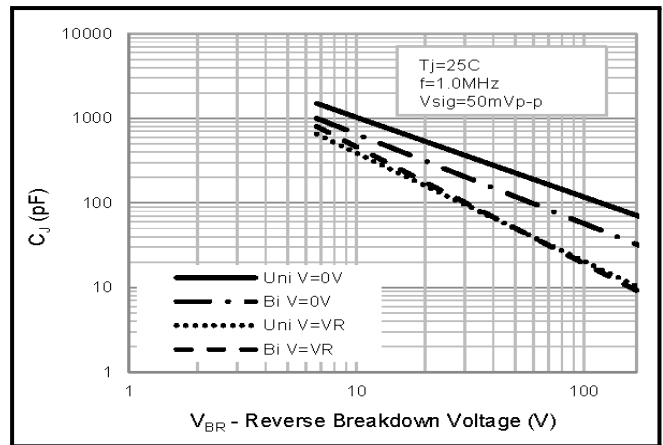

Figure 5: Steady State Power Dissipation Derating Curve

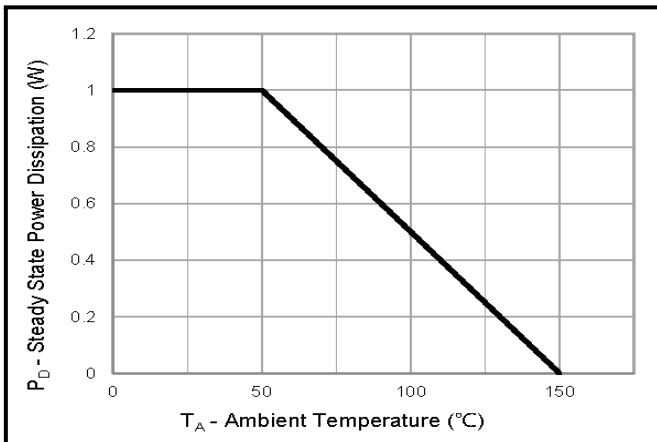
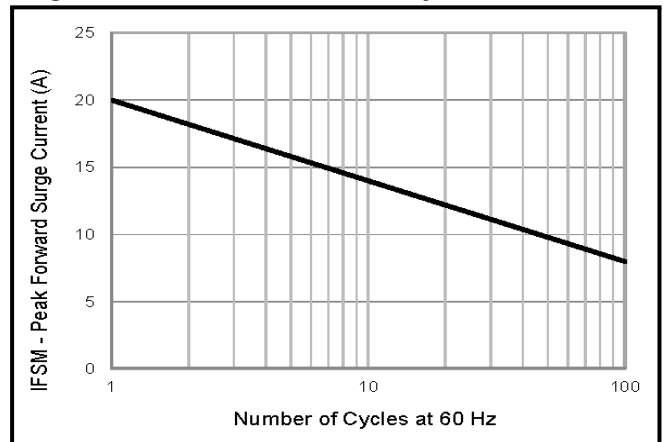
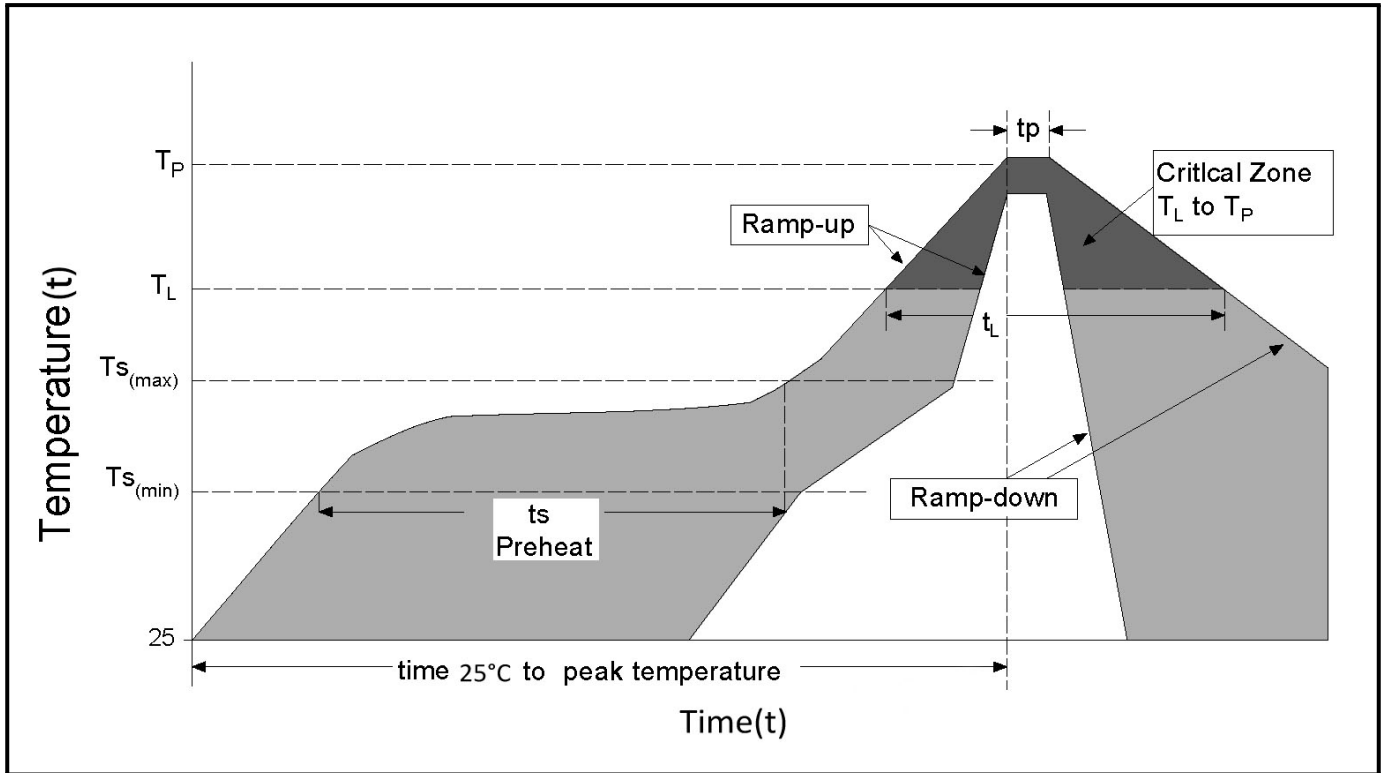

Figure 6: Maximum Non-Repetitive Peak Forward Surge Current Uni-Directional Only



Soldering Parameters



Reflow Condition		Lead-free assembly
Pre Heat	- Temperature Min ($T_{S(min)}$)	150°C
	- Temperature Max ($T_{S(max)}$)	200°C
	- Time (min to max) (t_s)	60 - 180 secs
Average ramp up rate (Liquidus Temp (T_L) to peak)		3°C/second max
$T_{S(max)}$ to T_L - Ramp-up Rate		3°C/second max
Reflow	- Temperature (T_L) (Liquidus)	217°C
	- Time (t_L)	60 -150 secs
Peak Temperature (T_P)		260 ^{+0/-5} °C
Time within 5°C of actual peak Temperature (t_p)		20 - 40 secs
Ramp-down Rate		6°C/second max
Time 25°C to peak Temperature (t)		8 minutes Max.
Do not exceed		260°C



SMFJ / HSMFJ Series

**Transient
Voltage Suppressor**

Package Mechanical Data - SOD-123F

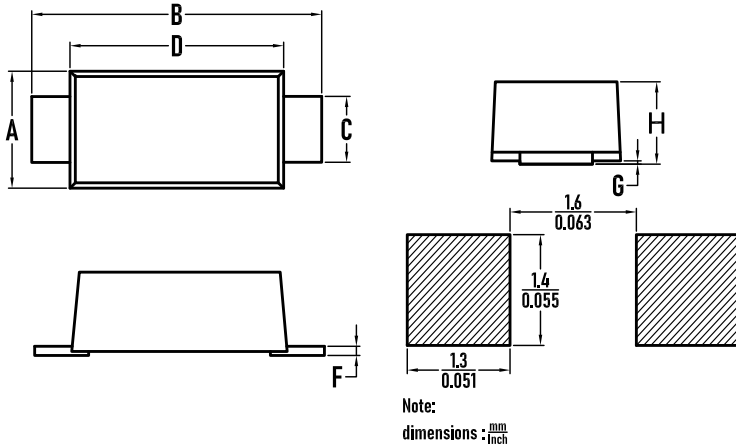

SYMBOL	MILLIMETER		
	MIN.	Typ.	MAX.
A	1.60	1.80	2.00
B	3.40	3.60	3.80
C	0.90	1.00	1.10
D	2.50	2.70	2.90
F	0.10	0.15	0.20
G	0.00	—	0.02
H	1.00	1.10	1.20

Packaging Tape - SOD-123F

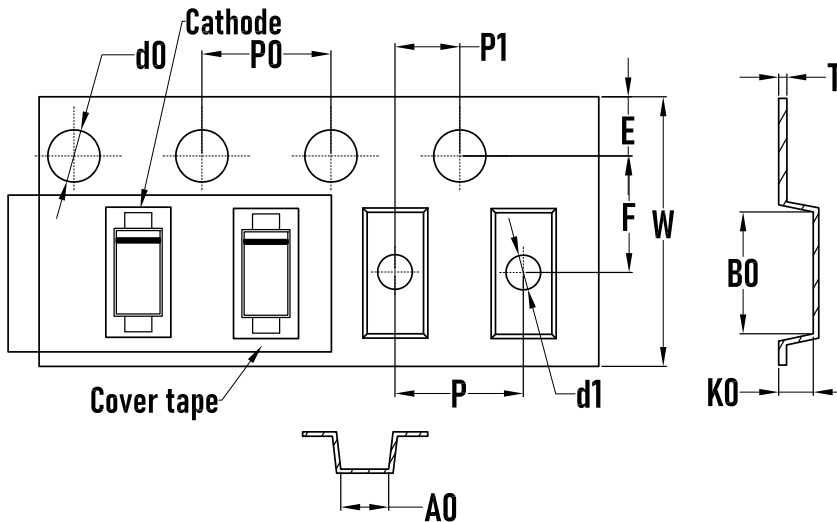

SYMBOL	MILLIMETER
A0	2.10±0.1
B0	4.0 ±0.1
d0	1.5±0.1
d1	1.0±0.1
E	1.75±0.1
F	3.50±0.1
K0	1.25±0.1
P	4.00±0.1
P0	4.00±0.1
P1	2.00±0.1
W	8.00±0.1
T	0.2±0.02

Packaging Reel

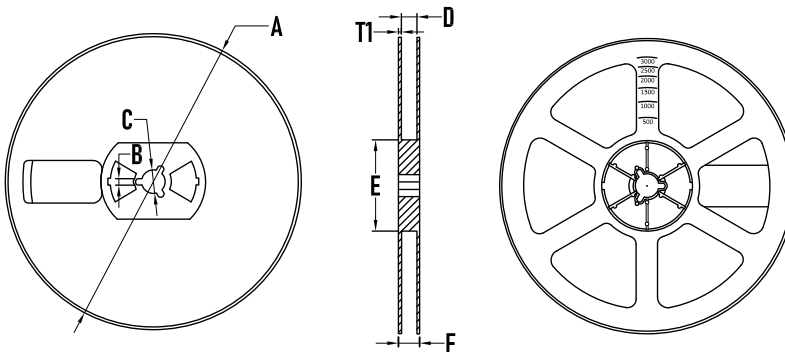

SYMBOL	MILLIMETER
A	177.8±0.2
B	2.7±0.2
C	13.5±0.2
D	9.6±0.3
E	54.5±0.2
F	12.3±0.3
T1	1.0±0.2
Quantity	3000PCS

