

SS32-SS320

Schottky Barrier Diode

Features

- For surface mounted applications
- Metal silicon junction, majority carrier conduction
- Low power loss, high efficiency
- Built-in strain relief, ideal for automated placement
- High forward surge current capability
- High temperature soldering guaranteed:
250°C/10 seconds at terminals

Package

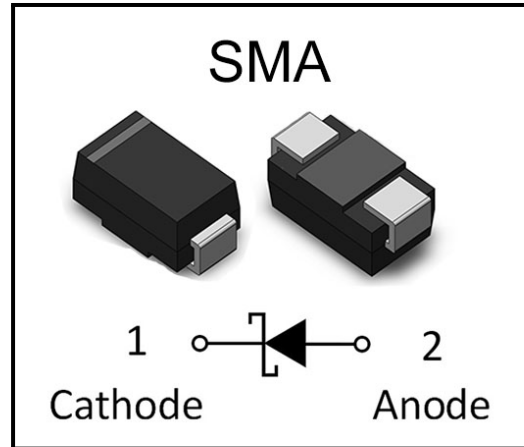

Description

- Case: JEDEC DO-214AC molded plastic
- Terminals: Axial leads. Solderable per MIL-STD-750 Method 2026
- Polarity: Color band denotes cathode
- Mounting Position: Any

Marking

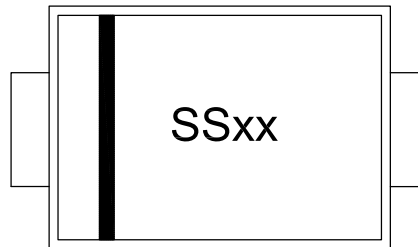

Ordering information

Part Number	SS32	SS33	SS34	SS35	SS36	SS38	SS310	SS315	SS320
Marking	SS32	SS33	SS34	SS35	SS36	SS38	SS310	SS315	SS320
Base qty	5K	5K	5K	5K	5K	5K	5K	5K	5K



SS32-SS320

Schottky Barrier Diode

Maximum Ratings and Electrical Characteristics@T_A=25°C unless otherwise noted

Symbol	Parameters	SS	SS	SS	SS	SS	SS	SS	SS	SS	Units
		32	33	34	35	36	38	310	315	320	
V _{RRM}	Maximum Recurrent Peak Reverse Voltage	20	30	40	50	60	80	100	150	200	V
V _{RMS}	Maximum RMS Voltage	14	21	28	35	42	56	70	105	140	V
V _{DC}	Maximum DC Blocking Voltage	20	30	40	50	60	80	100	150	200	V
I _{AV}	Maximum Average Forward Rectified Current	3.0									A
I _{FSM}	Peak Forward Surge Current 8.3ms single half sine-wave superimposed on rated	70									A
V _F	Maximum Forward Voltage at 3.0A DC	0.55			0.70		0.85		0.95		V
I _R	Maximum DC reverse current@T _A =25°C	0.50					0.10				mA
	Maximum DC reverse current@T _A =100°C	10					5				
R _{θJA} ⁽¹⁾	Typical Thermal Resistance	55									°C/W
T _J	Operating Junction Temperature Range	-55 to +150					-55 to +175				°C
T _{STG}	Storage Temperature Range	-55 to +150									°C

Note: (1)Thermal resistance from junction to ambient and from junction to lead mounted on P.C.B. with 0.2" x 0.2" (5.0 mm x 5.0 mm) copper pad areas



SS32-SS320

Schottky Barrier Diode

Typical Performance Characteristics ($T_J = 25^\circ\text{C}$, unless otherwise noted)

Figure 1: $I_{AV}-T_L$ Curve

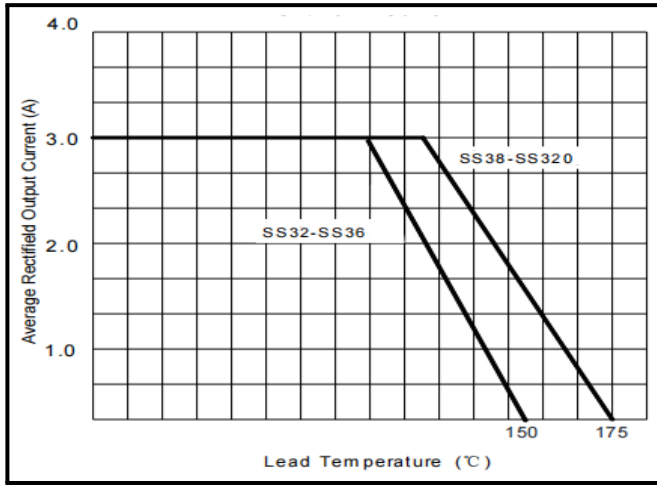

Figure 2: Surge Forward Current Capability

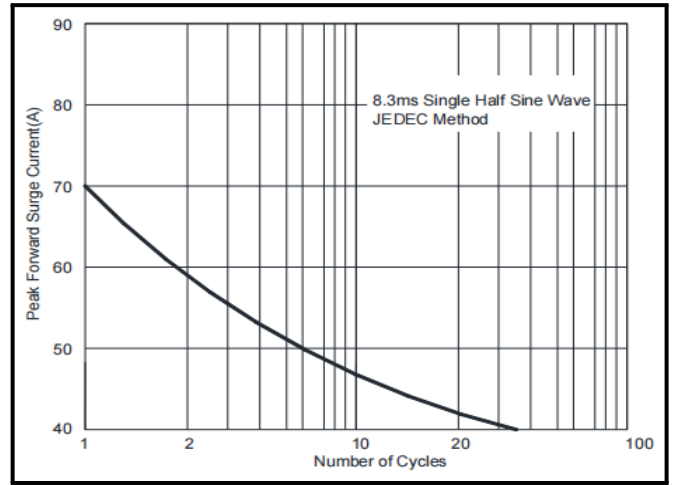

Figure 3: Typical Forward Characteristics

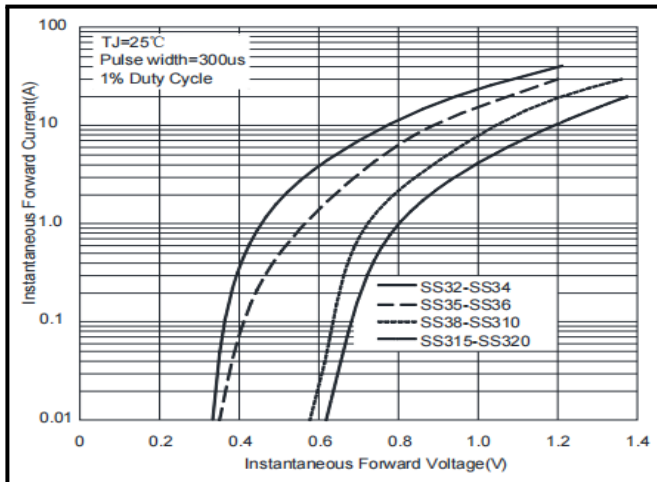
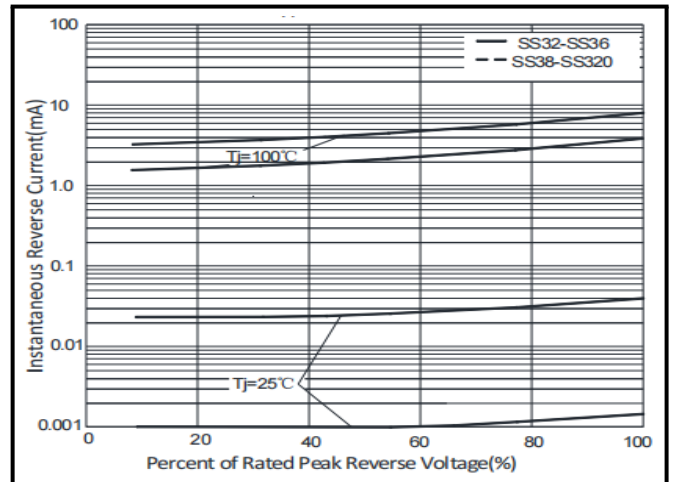

Figure 4: Typical Reverse Characteristics



SS32-SS320

Schottky Barrier Diode

Outline Drawing - SMA

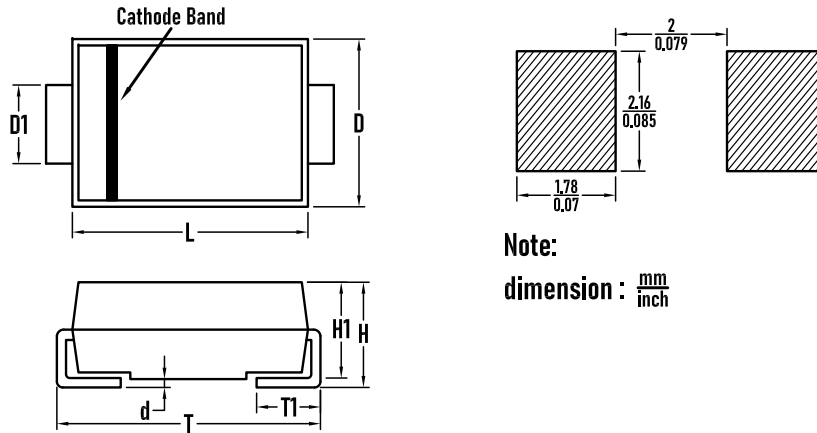

Note:
dimension : $\frac{\text{mm}}{\text{inch}}$

SYMBOL	MILLIMETER	
	MIN	MAX
D	2.50	2.90
D1	1.20	1.60
T	4.80	5.28
T1	0.76	1.52
d	0.051	0.203
H1	1.80	2.20
H	2.00	2.44
L	4.00	4.60

Packaging Tape - SMA

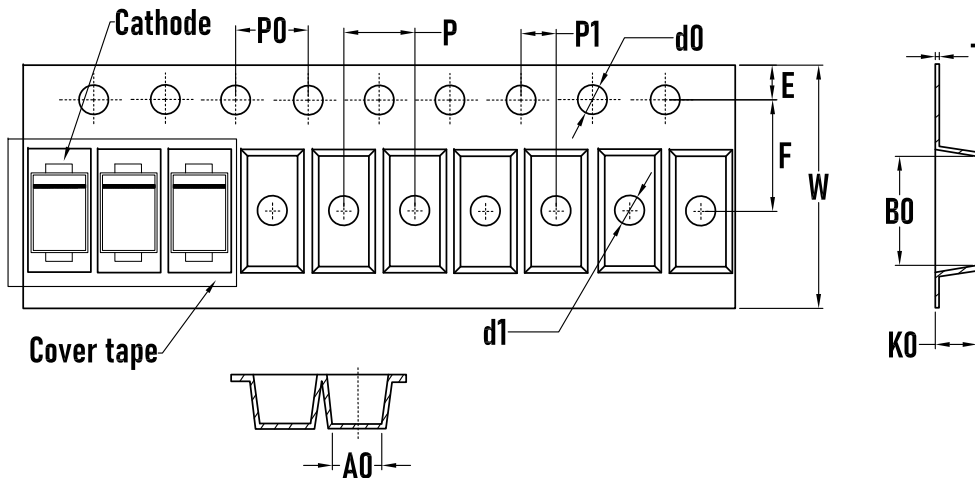

SYMBOL	MILLIMETER
A0	2.70
B0	5.10±0.1
d0	1.50±0.1
d1	1.50±0.1
E	1.75±0.1
F	5.50±0.1
K0	2.40±0.1
P	4.00±0.1
P0	4.00±0.1
P1	2.00±0.1
W	12.00±0.1
T	0.2±0.02

Packaging Reel

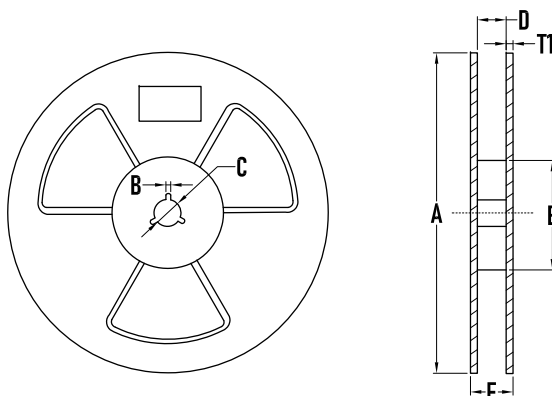

SYMBOL	MILLIMETER
A	323±2
B	3.0±0.2
C	15.0±0.5
D	13±2
E	73±2
T1	2.2±0.2
Quantity	5000PCS

**BORN SEMICONDUCTOR, INC. ALL
RIGHT RESERVED**

Specifications are subject to change without notice.

Please refer to <http://www.born-tw.com> for current information.

Revision: 2022-Jan-1-A

