



Features

- Repeatable settings
- Resolution to 0.001 %
- Digital display provides excellent readability
- Snap-in panel mount
- RoHS compliant*

3680 Family - Precision Potentiometer

Electrical Characteristics¹

Standard Resistance Range.....	10 ohms to 1 megohm
Total Resistance Tolerance.....	±3 %
Dielectric Withstanding Voltage (MIL-STD-202, Method 301)	
Sea Level	1,000 VAC minimum
Power Rating (Voltage Limited By Power Dissipation or 500 VAC, Whichever is Less)	
+25 °C	2 watts
+85 °C	0 watt
Insulation Resistance (500 VDC)	1,000 megohms minimum
Resolution	
3681	10 %
3682	1 %
3683	0.1 %
3684	0.01 %
3685	0.001 %
Absolute Minimum Resistance	3 ohms or 0.2 % maximum (whichever is greater)
Accuracy (Dial Reading to Output Ratio).....	±1.0 % full scale

Environmental Characteristics¹

Operating Temperature Range	-25 °C to +85 °C
Storage Temperature Range	-25 °C to +85 °C
Temperature Coefficient Over Storage Temperature Range	±100 ppm/°C maximum
Vibration	10 G
Wiper Bounce	0.1 millisecond maximum
Total Resistance Shift.....	±1 % maximum
Voltage Ratio Shift	±0.2 % maximum
Shock.....	50 G
Wiper Bounce	0.1 millisecond maximum
Total Resistance Shift.....	±1 % maximum
Voltage Ratio Shift	±0.2 % maximum
Load Life.....	1,000 hours, 2 watts
Total Resistance Shift.....	±2 % maximum
Rotational Life.....	75,000 button operations each decade
Total Resistance Shift.....	±2 % maximum
IP Rating.....	IP 40

Mechanical Characteristics¹

Weight	3681 (9 gm); 3682 (16 gm); 3683 (23 gm); 3684 (30 gm); 3685 (37 gm)
Terminals	2.79 mm (0.11 in.) wide x .41 mm (.016 in.) thick, tinned solder lugs for 3 #20 AWG wires
Soldering Condition	
Manual Soldering.....	96.5Sn/3.0Ag/0.5Cu solid wire or no-clean rosin cored wire; 370 °C (700 °F) max. for 3 seconds
Wave Soldering	96.5Sn/3.0Ag/0.5Cu solder with no-clean flux; 260 °C (500 °F) max. for 5 seconds
Wash processes	Not recommended
Marking.....	Manufacturer's name and part number, resistance value and date code.
Ganging (Multiple Section Potentiometers)	Up to 5 decades maximum
Readout Marking	10 positions, 0-9
Actuating Force	19 to 29 oz. on detent decades
Actuating Force Variation	4 oz. maximum

¹ At room ambient: +25 °C nominal and 50 % relative humidity nominal, except as noted.
NOTE: Terminals 1 & 3 are reversed from illustration for models 3682 and 3684.

Product Dimensions

Model	Dimensions					Weight (Approx.)	
	a	b	c	d	e ±.381 (±.015)	oz.	gms.
3681	16.51 (.650)	14.99 (.590)	—	9.91 (.39)	4.19 (.165)	.336	9.5
3682	26.67 (1.05)	25.15 (.99)	10.67 (.42)	11.94 (.47)	8.38 (.330)	.576	16.5
3683	37.08 (1.46)	35.31 (1.39)	18.54 (.73)	11.94 (.47)	4.19 (.165)	.824	23.5
3684	47.50 (1.87)	45.47 (1.79)	30.73 (1.21)	11.94 (.47)	8.38 (.330)	1.072	30.5
3685	57.66 (2.270)	55.63 (2.190)	39.12 (1.540)	11.94 (.47)	4.19 (.165)	1.320	37.5

Model	Dimensions	
	f ±.010 (±.254)	g ±.010 (±.254)
3681	21.08 (.830)	15.75 (.620)
3682	21.08 (.830)	25.91 (1.020)
3683	21.08 (.830)	36.07 (1.420)
3684	21.08 (.830)	46.23 (1.820)
3685	21.08 (.830)	56.39 (2.220)

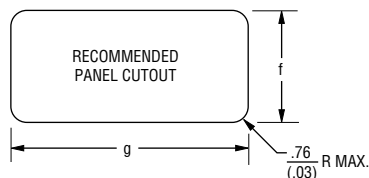

Product Dimensions

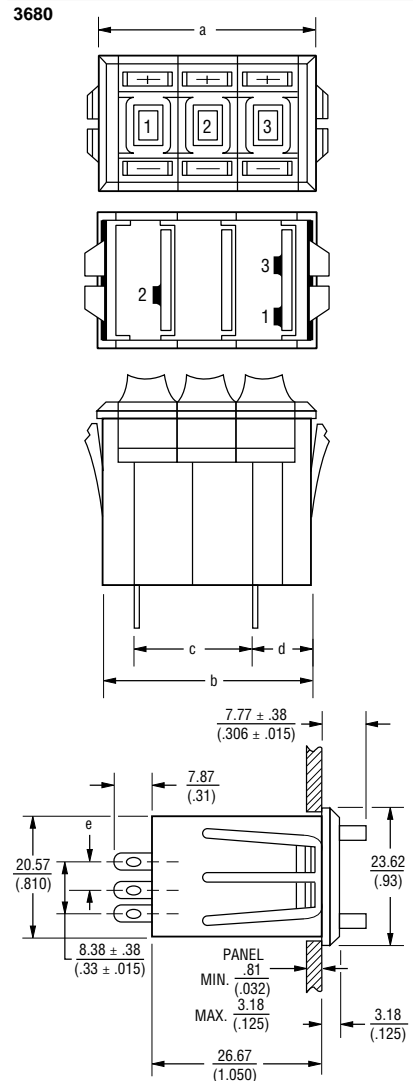

TOLERANCES: EXCEPT WHERE NOTED
DECIMALS: XX ± .38 (.015) .XXX ± .13 (.005)
FRACTIONS: ±1/64
DIMENSIONS: MM (IN.)

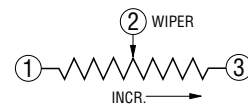

WARNING
Cancer and Reproductive Harm
www.P65Warnings.ca.gov

*RoHS Directive 2015/863, Mar 31, 2015 and Annex.

Specifications are subject to change without notice. Users should verify actual device performance in their specific applications.

The products described herein and this document are subject to specific disclaimers as set forth on the last page of this document, and at www.bourns.com/legal/disclaimer.pdf.

3680 Family - Precision Potentiometer

BOURNS®

Recommended Part Numbers

Resistance (Ω)	3681S-1 1 Decade	3682S-1 2 Decade	3683S-1 3 Decade	3684S-1 4 Decade	3685S-1 5 Decade
50	-500L				
100	-101L				
200	-201L				
500	-501L	-501L			
1,000	-102L	-102L	-102L		
2,000	-202L	-202L	-202L		
5,000	-502L	-502L	-502L		
10 K	-103L	-103L	-103L	-103L	
20 K		-203L	-203L	-203L	
50 K		-503L	-503L	-503L	
100 K	-104L	-104L	-104L	-104L	-104L
500 K			-504L	-504L	-504L
1 Meg		-105L	-105L	-105L	-105L

BOLDFACE LISTINGS ARE IN STOCK AND READILY AVAILABLE THROUGH DISTRIBUTION.

FOR OTHER OPTIONS CONSULT FACTORY.

ROHS IDENTIFIER:
L = COMPLIANT

BOURNS®

Asia-Pacific: Tel: +886-2 2562-4117 • Email: asiacus@bourns.com

EMEA: Tel: +36 88 885 877 • Email: eurocus@bourns.com

The Americas: Tel: +1-951 781-5500 • Email: americus@bourns.com

www.bourns.com

REV. 10/19

Specifications are subject to change without notice.

Users should verify actual device performance in their specific applications.

The products described herein and this document are subject to specific disclaimers as set forth on the last page of this document, and at www.bourns.com/legal/disclaimer.pdf.

Legal Disclaimer Notice

BOURNS®

This legal disclaimer applies to purchasers and users of Bourns® products manufactured by or on behalf of Bourns, Inc. and its affiliates (collectively, “Bourns”).

Unless otherwise expressly indicated in writing, Bourns® products and data sheets relating thereto are subject to change without notice. Users should check for and obtain the latest relevant information and verify that such information is current and complete before placing orders for Bourns® products.

The characteristics and parameters of a Bourns® product set forth in its data sheet are based on laboratory conditions, and statements regarding the suitability of products for certain types of applications are based on Bourns’ knowledge of typical requirements in generic applications. The characteristics and parameters of a Bourns® product in a user application may vary from the data sheet characteristics and parameters due to (i) the combination of the Bourns® product with other components in the user’s application, or (ii) the environment of the user application itself. The characteristics and parameters of a Bourns® product also can and do vary in different applications and actual performance may vary over time. Users should always verify the actual performance of the Bourns® product in their specific devices and applications, and make their own independent judgments regarding the amount of additional test margin to design into their device or application to compensate for differences between laboratory and real world conditions.

Unless Bourns has explicitly designated an individual Bourns® product as meeting the requirements of a particular industry standard (e.g., ISO/TS 16949) or a particular qualification (e.g., UL listed or recognized), Bourns is not responsible for any failure of an individual Bourns® product to meet the requirements of such industry standard or particular qualification. Users of Bourns® products are responsible for ensuring compliance with safety-related requirements and standards applicable to their devices or applications.

Bourns® products are not recommended, authorized or intended for use in nuclear, lifesaving, life-critical or life-sustaining applications, nor in any other applications where failure or malfunction may result in personal injury, death, or severe property or environmental damage. Unless expressly and specifically approved in writing by two authorized Bourns representatives on a case-by-case basis, use of any Bourns® products in such unauthorized applications might not be safe and thus is at the user’s sole risk. Life-critical applications include devices identified by the U.S. Food and Drug Administration as Class III devices and generally equivalent classifications outside of the United States.

Bourns expressly identifies those Bourns® standard products that are suitable for use in automotive applications on such products’ data sheets in the section entitled “Applications.” Unless expressly and specifically approved in writing by two authorized Bourns representatives on a case-by-case basis, use of any other Bourns® standard products in an automotive application might not be safe and thus is not recommended, authorized or intended and is at the user’s sole risk. If Bourns expressly identifies a sub-category of automotive application in the data sheet for its standard products (such as infotainment or lighting), such identification means that Bourns has reviewed its standard product and has determined that if such Bourns® standard product is considered for potential use in automotive applications, it should only be used in such sub-category of automotive applications. Any reference to Bourns® standard product in the data sheet as compliant with the AEC-Q standard or “automotive grade” does not by itself mean that Bourns has approved such product for use in an automotive application.

Bourns® standard products are not tested to comply with United States Federal Aviation Administration standards generally or any other generally equivalent governmental organization standard applicable to products designed or manufactured for use in aircraft or space applications. Bourns expressly identifies Bourns® standard products that are suitable for use in aircraft or space applications on such products’ data sheets in the section entitled “Applications.” Unless expressly and specifically approved in writing by two authorized Bourns representatives on a case-by-case basis, use of any other Bourns® standard product in an aircraft or space application might not be safe and thus is not recommended, authorized or intended and is at the user’s sole risk.

The use and level of testing applicable to Bourns® custom products shall be negotiated on a case-by-case basis by Bourns and the user for which such Bourns® custom products are specially designed. Absent a written agreement between Bourns and the user regarding the use and level of such testing, the above provisions applicable to Bourns® standard products shall also apply to such Bourns® custom products.

Users shall not sell, transfer, export or re-export any Bourns® products or technology for use in activities which involve the design, development, production, use or stockpiling of nuclear, chemical or biological weapons or missiles, nor shall they use Bourns® products or technology in any facility which engages in activities relating to such devices. The foregoing restrictions apply to all uses and applications that violate national or international prohibitions, including embargos or international regulations. Further, Bourns® products and Bourns technology and technical data may not under any circumstance be exported or re-exported to countries subject to international sanctions or embargoes. Bourns® products may not, without prior authorization from Bourns and/or the U.S. Government, be resold, transferred, or re-exported to any party not eligible to receive U.S. commodities, software, and technical data.

To the maximum extent permitted by applicable law, Bourns disclaims (i) any and all liability for special, punitive, consequential, incidental or indirect damages or lost revenues or lost profits, and (ii) any and all implied warranties, including implied warranties of fitness for particular purpose, non-infringement and merchantability.

For your convenience, copies of this Legal Disclaimer Notice with German, Spanish, Japanese, Traditional Chinese and Simplified Chinese bilingual versions are available at:

Web Page: <http://www.bourns.com/legal/disclaimers-terms-and-policies>

PDF: <http://www.bourns.com/docs/Legal/disclaimer.pdf>

X-ON Electronics

Largest Supplier of Electrical and Electronic Components

Click to view similar products for [Precision Potentiometers](#) category:

Click to view products by [Bourns](#) manufacturer:

Other Similar products are found below :

[578002M9648](#) [70J1G032S202A](#) [176FL1-284](#) [F78SB102-M257](#) [3548H-1AA-103B](#) [485025M9267](#) [MH12B-10L-10K](#) [578005M9656](#)
[72N4N048S203W](#) [RO200SF1C103](#) [114BF2A102-L774](#) [200FL1-199](#) [78FL1-397](#) [78MKV-128](#) [501-0004](#) [501-0018](#) [SE15303-352-T4](#)
[284TCBF103A26A1](#) [RO34SF1B502](#) [200FL1-260](#) [4205R10KL.5](#) [3548H-1AB-502A](#) [157-0237](#) [1521R10KL.3](#) [284TBBK103A26B1](#) [SP22G-](#)
[500](#) [DC22-10-100](#) [JC22S 1K 0.5%](#) [RCL-100](#) [RCL-200](#) [3590P-4-503L](#) [380C2750K](#) [3548H-1AA-102B](#) [380C2500K](#) [3590P-1-103L](#) [3547S-](#)
[1AA-202A](#) [534B1250JC](#) [3540S-91-502L](#) [3543S-1-202L](#) [3543S-1-102L](#) [3543S-1-502L](#) [3545S-1-103L](#) [3549S-2AA-102/102A](#) [P3265](#) [P3270](#)
[P3275](#) [P3280](#) [P3285](#) [P3290](#) [6637S-1-102](#)