



## Features

- Small package dimensions
- RoHS compliant\*
- Power rating at 70 °C = 1/16 W
- Tight dimensional tolerances
- Three layer termination process with nickel barrier prevents leaching and provides excellent solderability
- Suitable for most types of soldering processes
- Standard packaging on paper tape and reel

## CR0402 - Chip Resistor

### Electrical Characteristics

Power Rating @ 70 °C .....1/16 W  
 Operating Temperature Range  
 .....-55 °C to +155 °C  
 Derated to 0 Load at.....+155 °C  
 Maximum Working Voltage.....50 V  
 Maximum Overload Voltage .....100 V  
 Resistance Range  
 1 %, E-96  
 and E-24..... 10 ohms to 10 megohms  
 5 %, E-24 ..... 1 ohm to 20 megohms  
 Zero Ohm Jumper.....<0.05 ohms  
 Temperature Coefficient  
 1 % ..... 10 Ω ≤ R ≤ 1 MΩ ±100 ppm/°C  
 1 MΩ < R ≤ 10 MΩ ±200 ppm/°C  
 5 % ..... 10 Ω ≤ R ≤ 10 MΩ ±200 ppm/°C  
 10 MΩ < R ≤ 20 MΩ ±400 ppm/°C  
 1 Ω ≤ R < 10 Ω -200 to +500 ppm/°C  
 AEC-Q200 ..... Contact Bourns  
 to confirm availability

### Derating Curve

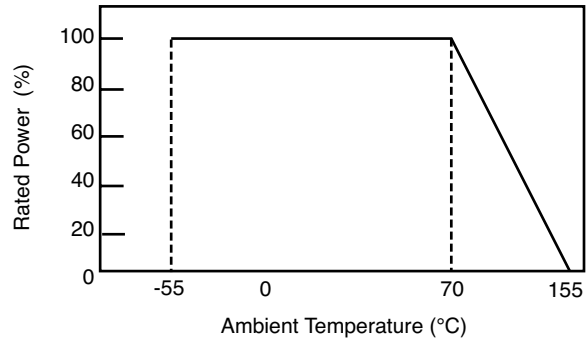

### Standard Values

For Standard Values Used in Capacitors, Inductors, and Resistors, [click here](#).

### Part Marking System

No Marking on the CR0402 Chip Resistors.

### Dimensional Drawings

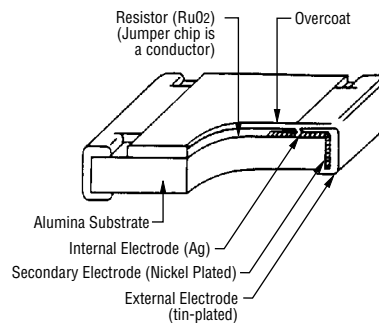
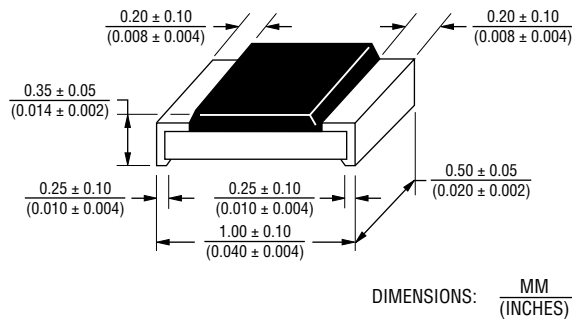

### Performance Characteristics

Test	Procedure	Method	Test Limits ΔR	
			1 %	5 %
Thermal Shock	-55 °C for 30 minutes, +155 °C for 30 minutes, 5 cycles	IEC60115-1-4.19	≤±(0.5 % + 0.05 Ω)	≤±(1 % + 0.05 Ω)
Short Time Overload	2.5 X rated voltage for 5 seconds	IEC60115-1-4.13	≤±(2 % + 0.1 Ω)	
Resistance to Solder Heat	270 ±5 °C for 10 ±1 seconds	IEC60115-1-4.18	≤±(0.5 % + 0.05 Ω)	≤±(1 % + 0.05 Ω)
Resistance to Dry Heat	125 ±5 °C for 96 ±4 hours	IEC60115-1-4.23.2	≤±(1 % + 0.05 Ω)	≤±(2 % + 0.1 Ω)
Load Life	Rated voltage for 1000 hours, 70 °C, 1.5 hours "ON", 0.5 hours "OFF"	IEC60115-1-4.25.1	≤±(3 % + 0.1 Ω)	
Load Life with Humidity	Rated voltage for 1000 hours, 40 ±2 °C, 90~95 % RH, 1.5 hours "ON", 0.5 hours "OFF"	IEC60115-1-4.24	≤±(3 % + 0.1 Ω)	
Solderability	245 ±5 °C, 2 ±0.5 seconds	IEC60115-1-4.17	≥95 % of area covered	
Bending	3 mm	IEC60115-1-4.33	≤±(0.5 % + 0.05 Ω)	≤±(1 % + 0.05 Ω)
Dielectric Withstanding Voltage	--	IEC60115-1-4.7	>100 V	
Insulation Resistance	100 V	IEC60115-1-4.6	≥1 GΩ	

\*RoHS Directive 2002/95/EC Jan. 27, 2003 including annex and RoHS Recast 2011/65/EU June 8, 2011. Specifications are subject to change without notice.

The device characteristics and parameters in this data sheet can and do vary in different applications and actual device performance may vary over time. Users should verify actual device performance in their specific applications.

# CR0402 - Chip Resistor

**BOURNS®**

## Soldering Profile for RoHS Compliant Chip Resistors and Arrays

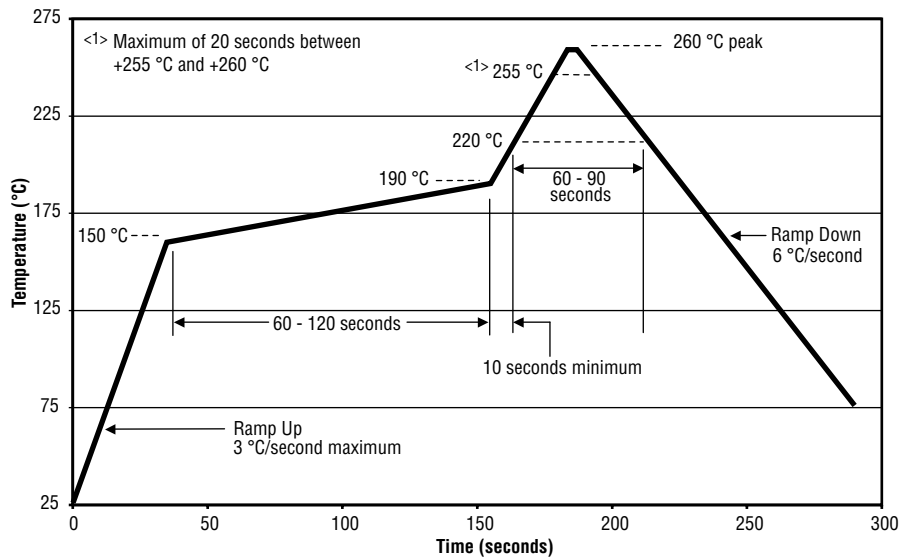

## Packaging Dimensions (Conforms to EIA RS-481A)

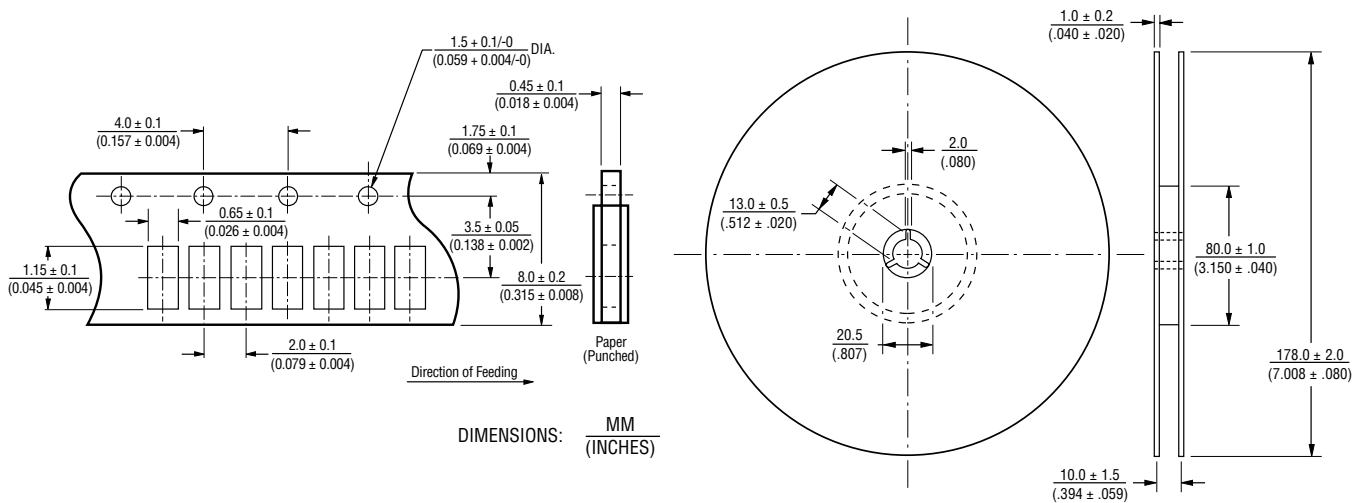

Specifications are subject to change without notice. The device characteristics and parameters in this data sheet can and do vary in different applications and actual device performance may vary over time. Users should verify actual device performance in their specific applications.

# CR0402 - Chip Resistor

**BOURNS®**

## How to Order

CR 0402 - F X - 8252 G LF

Model \_\_\_\_\_  
(CR = Chip Resistor)

Size \_\_\_\_\_  
• 0402

Resistance Tolerance \_\_\_\_\_  
F = ±1 % .....Used with "X" TCR code only for values from 10 ohms through 1 megohm; and  
Used with "W" TCR code only for values above 1 megohm. through 10 megohms.  
J = ±5 % ..... Used with "W" TCR code for values from 10 ohms through 10 megohms;  
Used with "Z" TCR code for values above 10 megohms through 20 megohms;  
Used with "/" TCR code for zero ohm (jumper); and for values from 1 ohm through 9.1 ohms.

TCR (ppm/°C) \_\_\_\_\_  
X = ±100  
W = ±200  
Z = ±400  
/ = -200 to +500

Resistance Value \_\_\_\_\_  
For 1 % Tolerance:  
<100 ohms ..... "R" designates decimal point (example: 24R3 = 24.3 ohms)  
≥100 ohms.....First three digits are significant, fourth digit represents number of zeros to follow (example: 8252 = 82.5k ohms).  
For 5 % Tolerance:  
<10 ohms ..... "R" designates decimal point (example: 4R7 = 4.7 ohms)  
≥10 ohms.....First two digits are significant, third digit represents number of zeros to follow (example: 474 = 470k ohms; 000 = Jumper).

Packaging \_\_\_\_\_  
G = Paper Tape (10,000 pcs.) on 7 " Plastic Reel

Termination \_\_\_\_\_  
LF = Tin-plated (RoHS compliant)

REV. 11/16

Specifications are subject to change without notice.

The device characteristics and parameters in this data sheet can and do vary in different applications and actual device performance may vary over time. Users should verify actual device performance in their specific applications.

## X-ON Electronics

Largest Supplier of Electrical and Electronic Components

*Click to view similar products for [Thick Film Resistors - SMD category](#):*

*Click to view products by [Bourns manufacturer](#):*

Other Similar products are found below :

[CR-05FL7--150R](#) [CR-05FL7--19K6](#) [CR-05FL7--243R](#) [CR-05FL7--40K2](#) [CR-05FL7--698K](#) [CR-12FP4--324R](#) [CR-12JP4--680R](#)

[M55342K06B6E19RWL](#) [MC0603-511-JTW](#) [742C083750JTR](#) [MCR01MZPF1202](#) [MCR01MZPF1601](#) [MCR01MZPF1800](#)

[MCR01MZPF6201](#) [MCR01MZPF9102](#) [MCR01MZPJ113](#) [MCR01MZPJ121](#) [MCR01MZPJ125](#) [MCR01MZPJ751](#) [MCR03EZHJ103](#)

[MCR03EZPFX2004](#) [MCR03EZPJ270](#) [MCR03EZPJ821](#) [MCR10EZPF1102](#) [MCR18EZPJ330](#) [RC0603F1473CS](#) [RC0603F150CS](#)

[RC1005F1152CS](#) [RC1005F1372CS](#) [RC1005F1912CS](#) [RC1005F2052CS](#) [RC1005F3011CS](#) [RC1005F4642CS](#) [RC1005F471CS](#)

[RC1005F4751CS](#) [RC1005F5621CS](#) [RC1005F6041CS](#) [RC1005J106CS](#) [RC1005J121CS](#) [RC1005J122CS](#) [RC1005J154CS](#) [RC1005J180CS](#)

[RC1005J181CS](#) [RC1005J202CS](#) [RC1005J272CS](#) [RC1005J391CS](#) [RC1005J471CS](#) [RC1005J512CS](#) [RC1005J560CS](#) [RC1005J823CS](#)