

Features

- Formerly J.W. Miller® model
- Height of 5.4 mm
- Current rating up to 2.65 A
- RoHS compliant*



This series is obsolete and not recommended for new designs.

PM125S Series - Shielded SMD Power Inductors

Electrical Specifications

Bourns Part No.	Inductance 100 kHz		Test Frequency (MHz)	SRF MHz Typ.	DCR Max. (mΩ)	Idc (A)	Isat (A)
	(μH)	Tol. (%)					
PM125S-100M-RC	10	±20	2.52	24	50	2.65	4.43
PM125S-120M-RC	12	±20	2.52	21	50	2.50	5.31
PM125S-150M-RC	15	±20	2.52	19	60	2.45	3.68
PM125S-180M-RC	18	±20	2.52	16	60	2.40	4.32
PM125S-220M-RC	22	±20	2.52	15	70	2.20	4.04
PM125S-270M-RC	27	±20	2.52	14	80	2.00	3.62
PM125S-330M-RC	33	±20	2.52	13	100	1.80	3.00
PM125S-390M-RC	39	±20	2.52	12	110	1.65	3.00
PM125S-470M-RC	47	±20	2.52	10	120	1.50	1.78
PM125S-560M-RC	56	±20	2.52	9	150	1.38	1.90
PM125S-680M-RC	68	±20	2.52	9	170	1.26	2.08
PM125S-820M-RC	82	±20	2.52	8	200	1.14	1.82
PM125S-101M-RC	100	±20	1.00	7	250	1.05	1.19
PM125S-121M-RC	120	±20	1.00	6	280	0.95	0.95
PM125S-151M-RC	150	±20	1.00	6	400	0.85	1.18
PM125S-181M-RC	180	±20	1.00	5	480	0.77	1.07
PM125S-221M-RC	220	±20	1.00	5	520	0.70	0.95
PM125S-271M-RC	270	±20	1.00	4	700	0.63	1.07
PM125S-331M-RC	330	±20	1.00	4	800	0.57	0.78
PM125S-391M-RC	390	±20	1.00	4	1080	0.52	0.91
PM125S-471M-RC	470	±20	1.00	3	1200	0.48	0.87
PM125S-561M-RC	560	±20	1.00	3	1340	0.44	0.74
PM125S-681M-RC	680	±20	1.00	3	1780	0.40	0.74
PM125S-821M-RC	820	±20	1.00	2	2000	0.36	0.26

Electrical Schematic

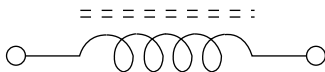

Typical Part Marking

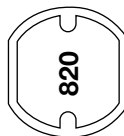

General Specifications

Test Voltage 0.1 V
 Reflow Soldering 230 °C; 50 sec max.
 Operating Temperature
 -40 °C to +125 °C
 (Temperature rise included)
 Storage Temperature ... -40 °C to +125 °C
 Resistance to Soldering Heat
 260 °C, 10 sec. max.

Materials

Core Ferrite
 Wire Enameled copper
 Adhesive Epoxy resin
 Terminal Sn/Ni/Ag
 Rated Current
 Ind. drop 10 % typ. at Isat
 Temperature Rise 40 °C typical
 at Idc
 Packaging 500 pcs. per reel

Product Dimensions

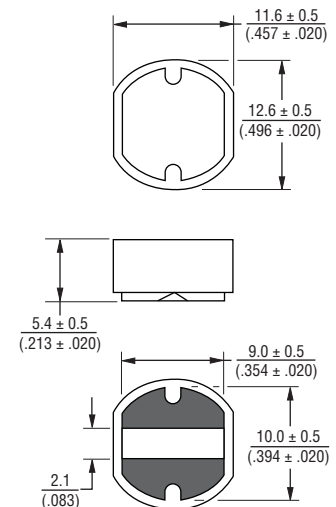

Recommended Pad Layout

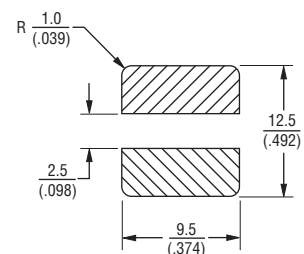

DIMENSIONS: $\frac{\text{MM}}{\text{(INCHES)}}$

*RoHS Directive 2002/95/EC Jan. 27, 2003 including annex and RoHS Recast 2011/65/EU June 8, 2011. Specifications are subject to change without notice.

The device characteristics and parameters in this data sheet can and do vary in different applications and actual device performance may vary over time. Users should verify actual device performance in their specific applications.

Applications

- Input/output of DC/DC converters
- Industrial electronics
- Power supplies for:
 - Portable communications equipment
 - Camcorders
 - LCD TVs
 - Car radios

PM125S Series - Shielded SMD Power Inductors

BOURNS®

Inductance vs. Current

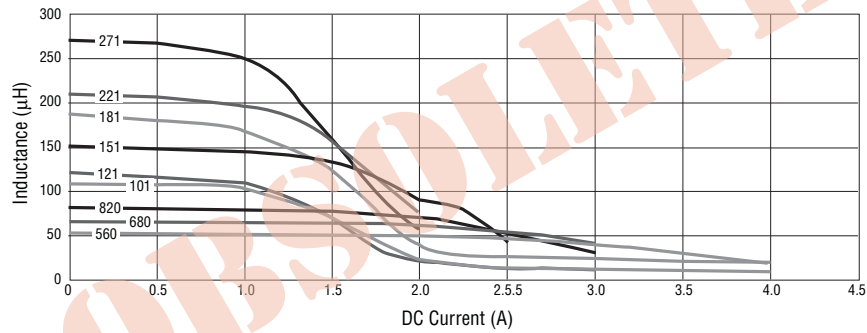
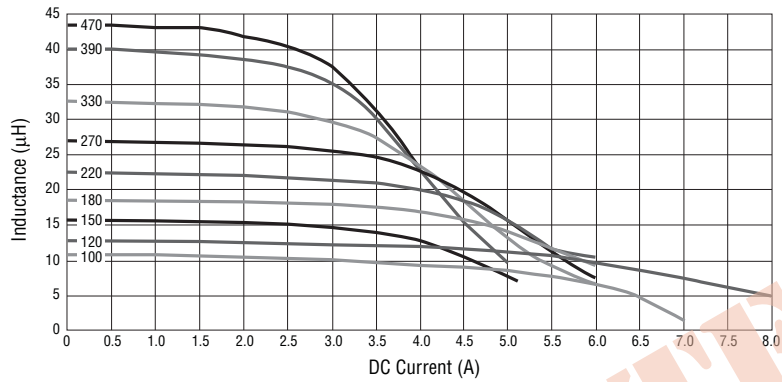

L vs. I

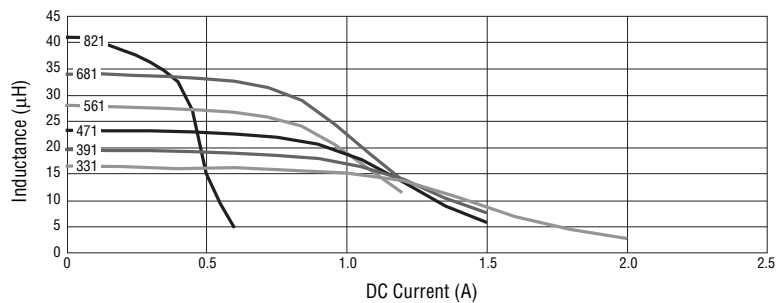

PM125S Series - Shielded SMD Power Inductors

BOURNS®

Packaging Specifications

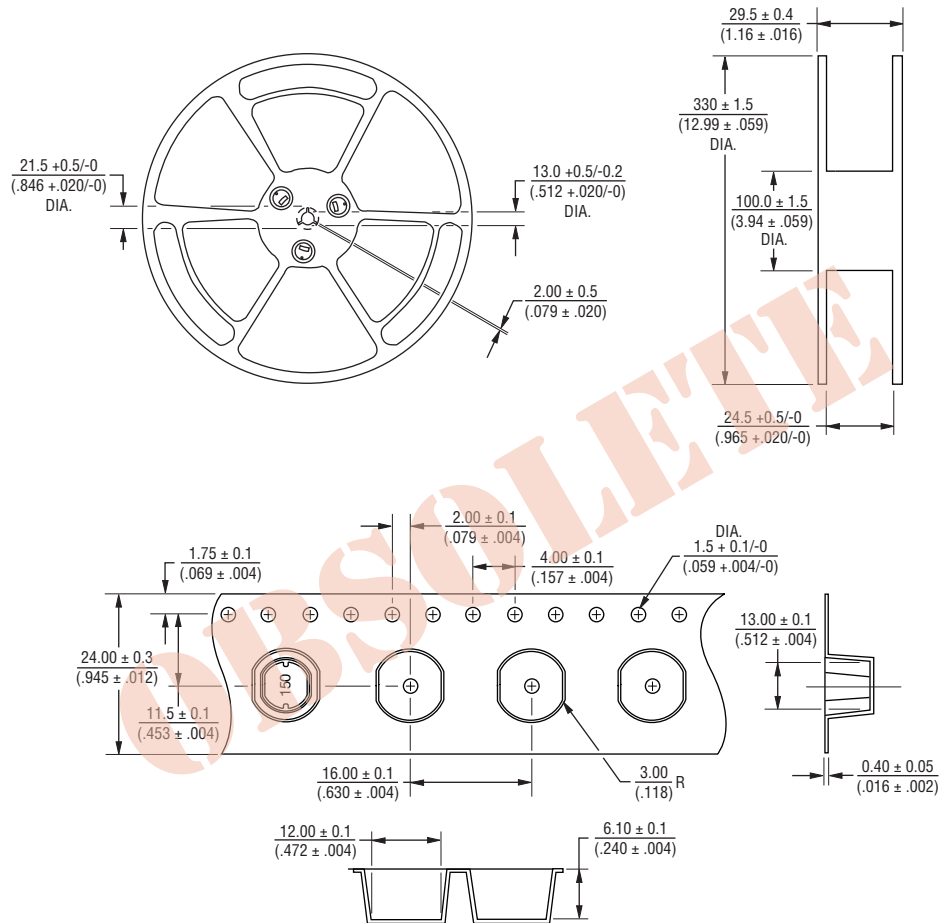

QTY: 500 PCS. PER REEL

DIMENSIONS: $\frac{\text{MM}}{\text{(INCHES)}}$

REV. 08/14

Specifications are subject to change without notice.

The device characteristics and parameters in this data sheet can and do vary in different applications and actual device performance may vary over time. Users should verify actual device performance in their specific applications.

X-ON Electronics

Largest Supplier of Electrical and Electronic Components

Click to view similar products for [Fixed Inductors](#) category:

Click to view products by [Bourns](#) manufacturer:

Other Similar products are found below :

[MLZ1608M6R8WTD25](#) [MLZ1608N6R8LT000](#) [MLZ1608N3R3LTD25](#) [MLZ1608N3R3LT000](#) [MLZ1608N150LT000](#)
[MLZ1608M150WTD25](#) [MLZ1608M3R3WTD25](#) [MLZ1608M3R3WT000](#) [MLZ1608M150WT000](#) [MLZ1608A1R5WT000](#)
[MLZ1608N1R5LT000](#) [B82432C1333K000](#) [PCMB053T-1R0MS](#) [PCMB053T-1R5MS](#) [PCMB104T-1R5MS](#) [CR32NP-100KC](#) [CR32NP-151KC](#) [CR32NP-180KC](#) [CR32NP-181KC](#) [CR32NP-1R5MC](#) [CR32NP-390KC](#) [CR32NP-3R9MC](#) [CR32NP-680KC](#) [CR32NP-820KC](#)
[CR32NP-8R2MC](#) [CR43NP-390KC](#) [CR43NP-560KC](#) [CR43NP-680KC](#) [CR54NP-181KC](#) [CR54NP-470LC](#) [CR54NP-820KC](#) [CR54NP-8R5MC](#)
[MGDQ4-00004-P](#) [MGDU1-00016-P](#) [MHL1ECTTP18NJ](#) [MHL1JCTTD12NJ](#) [PE-51506NL](#) [PE-53601NL](#) [PE-53630NL](#) [PE-53824SNLT](#) [PE-62892NL](#) [PE-92100NL](#) [PG0434.801NLT](#) [PG0936.113NLT](#) [PM06-2N7](#) [PM06-39NJ](#) [HC2LP-R47-R](#) [HC2-R47-R](#) [HC3-2R2-R](#) [HC8-1R2-R](#)