

Features

- Formerly **J. W. Miller**® model
- Available in E12 series
- Unit height of 3 mm
- Current up to 3 A
- RoHS compliant*

Applications

- Input/output of DC/DC converters
- Power supplies for:
 - Portable communication equipment
 - Camcorders
 - LCD TVs

PM1608S Series - Shielded Power Inductor

Electrical Specifications

Bourns Part No.	Inductance 100 kHz		Q Ref.	Test Frequency (kHz) Q	SRF Nom. (MHz)	RDC Max. (Ω)	IDC Max. (A)
	(μH)	Tol. %					
PM1608S-1R0M-RC	1.0	± 20	30	200	250	0.040	3.00
PM1608S-1R5M-RC	1.5	± 20	30	200	125	0.045	2.80
PM1608S-2R2M-RC	2.2	± 20	40	200	120	0.050	1.80
PM1608S-3R3M-RC	3.3	± 20	40	200	120	0.055	1.60
PM1608S-4R7M-RC	4.7	± 20	40	200	105	0.060	1.40
PM1608S-6R8M-RC	6.8	± 20	40	200	50	0.065	1.20
PM1608S-100M-RC	10	± 20	40	200	38	0.075	1.00
PM1608S-150M-RC	15	± 20	40	100	33	0.090	0.80
PM1608S-220M-RC	22	± 20	40	100	25	0.110	0.70
PM1608S-330M-RC	33	± 20	40	100	20	0.190	0.60
PM1608S-470M-RC	47	± 20	40	100	20	0.230	0.50
PM1608S-680M-RC	68	± 20	40	100	15	0.290	0.40
PM1608S-101M-RC	100	± 20	40	100	10	0.480	0.30
PM1608S-151M-RC	150	± 20	40	100	9	0.590	0.26
PM1608S-221M-RC	220	± 20	40	100	6	0.770	0.22
PM1608S-331M-RC	330	± 20	40	100	5	1.400	0.20
PM1608S-471M-RC	470	± 20	40	100	4	1.800	0.19
PM1608S-681M-RC	680	± 20	40	100	3	2.200	0.18
PM1608S-102M-RC	1000	± 20	40	100	2	3.400	0.15
PM1608S-152M-RC	1500	± 20	50	100	2	4.200	0.12
PM1608S-222M-RC	2200	± 20	50	100	2	8.500	0.10
PM1608S-332M-RC	3300	± 20	50	100	1	11.000	0.08
PM1608S-472M-RC	4700	± 20	50	100	1	13.900	0.06
PM1608S-682M-RC	6800	± 20	50	100	1	25.000	0.04
PM1608S-103M-RC	10,000	± 20	50	100	0.8	32.800	0.02

Electrical Schematic

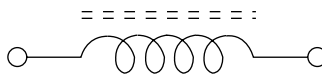

General Specifications

Test Voltage 0.1 V
 Reflow soldering 250 °C; 10 sec max.
 (In compliance with JEDEC, J-STD-020C, Table 4-2)
 Operating Temp. -55 °C to +125 °C
 (Temperature rise included)
 Storage Temperature .. -55 °C to +125 °C
 Resistance to Soldering Heat
 250 °C, 10 sec. max.
 Moisture Sensitivity Level 2
 ESD Classification (HBM) N/A

Materials

Core Ferrite DR & RI core
 Wire Enameled copper
 Base Ceramic
 Terminal Cu/Ni/Au
 Temp. Rise 30 °C max. at rated I_{rms}
 Packaging 600 pcs. per reel

Product Dimensions

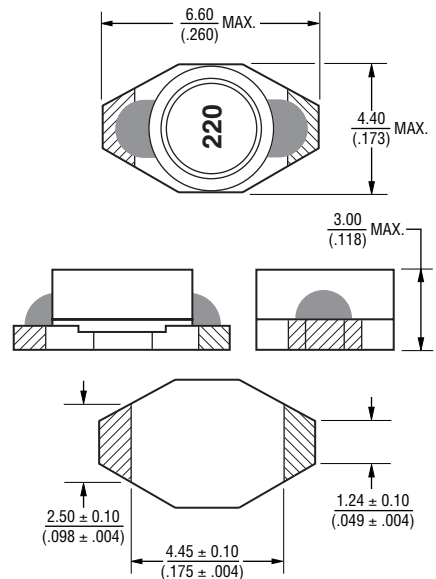

Recommended Layout

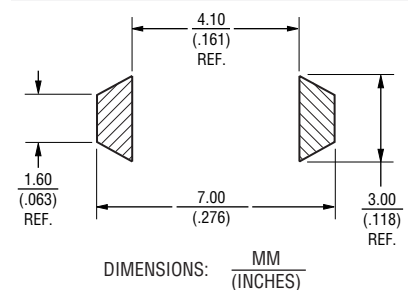

*RoHS Directive 2002/95/EC Jan. 27, 2003 including annex and RoHS Recast 2011/65/EU June 8, 2011.
 Specifications are subject to change without notice.
 The device characteristics and parameters in this data sheet can and do vary in different applications and actual device performance may vary over time.
 Users should verify actual device performance in their specific applications.

PM1608S Series - Shielded Power Inductor

BOURNS®

Soldering Profile

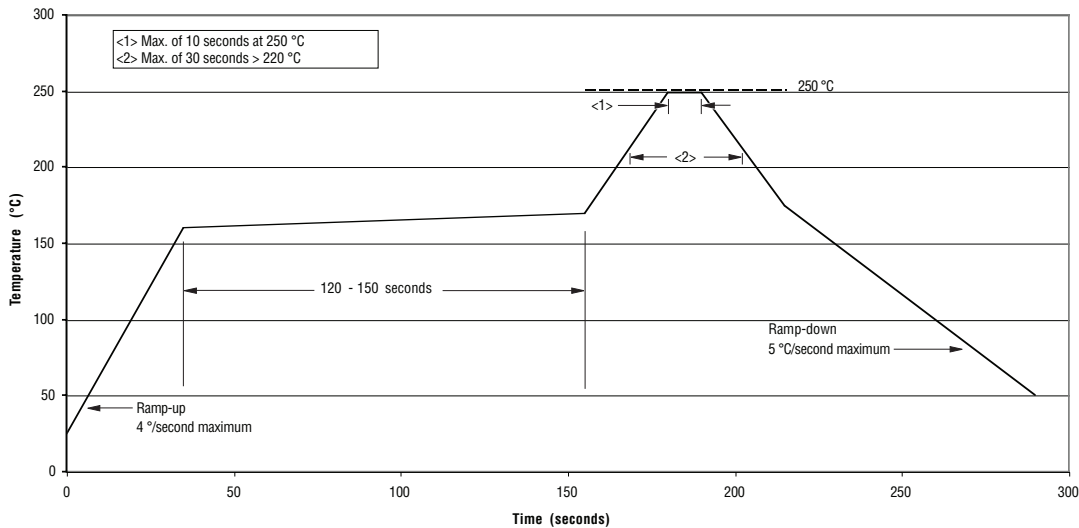

Packaging Specifications

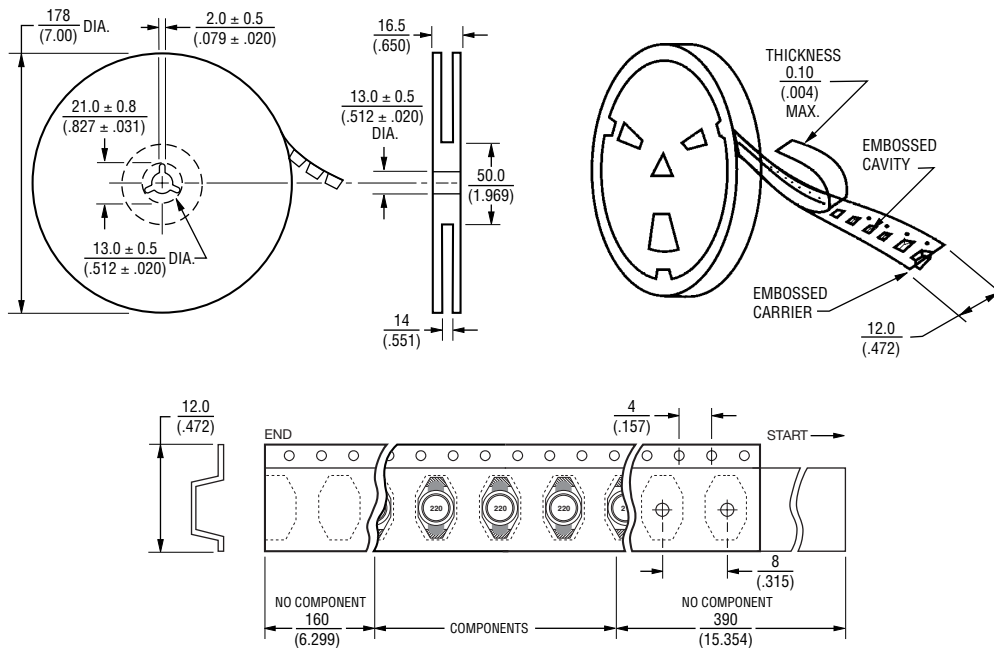

USER DIRECTION OF FEED

QTY: 600 PCS. PER REEL

DIMENSIONS: $\frac{\text{MM}}{\text{(INCHES)}}$

REV. 03/18

Specifications are subject to change without notice.

The device characteristics and parameters in this data sheet can and do vary in different applications and actual device performance may vary over time. Users should verify actual device performance in their specific applications.

X-ON Electronics

Largest Supplier of Electrical and Electronic Components

Click to view similar products for [Fixed Inductors](#) category:

Click to view products by [Bourns](#) manufacturer:

Other Similar products are found below :

[CR43NP-680KC](#) [CR54NP-820KC](#) [CR54NP-8R5MC](#) [CTX32CT-100](#) [70F224AI](#) [MGDQ4-00004-P](#) [MHL1ECTTP18NJ](#) [MHL1JCTTD12NJ](#)
[PE-51506NL](#) [PE-53601NL](#) [PE-53602NL](#) [PE-53630NL](#) [PE-53824SNLT](#) [PE-92100NL](#) [PG0434.801NLT](#) [PG0936.113NLT](#) [9310-16](#) [PM06-2N7](#) [PM06-39NJ](#) [A01TK](#) [1206CS-471XJ](#) [HC2-2R2TR](#) [HC2LP-R47-R](#) [HC3-2R2-R](#) [1206CS-151XG](#) [RCH664NP-140L](#) [RCH664NP-4R7M](#)
[RCH8011NP-221L](#) [RCP1317NP-332L](#) [RCP1317NP-391L](#) [RCR1010NP-470M](#) [RCR110DNP-331L](#) [DH2280-4R7M](#) [DS1608C-106](#) [ASPI-4020HI-R10M-T](#) [B10TJ](#) [B82477P4333M](#) [B82498B3101J000](#) [B82498B3680J000](#) [ELJ-RE27NJF2](#) [1812CS-153XJ](#) [1812CS-183XJ](#) [1812CS-223XJ](#) [1812LS-104XJ](#) [1812LS-105XJ](#) [1812LS-124XJ](#) [1812LS-154XJ](#) [1812LS-223XJ](#) [1812LS-224XJ](#) [1812LS-563XJ](#)