

## Features

- Carbon element
- Assortment of resistance tapers
- 45 mm and 60 mm travel lengths
- Single and dual gang elements
- Long operational life
- Tracking error within  $\pm 2$  dB
- Various lever styles



## PTE Series Low Profile Slide Potentiometer

### Electrical Characteristics

Standard Resistance Range ..... 1K ohms to 1 megohm  
 Standard Resistance Tolerance...  $\pm 20$  %  
 End Resistance ..... 2 ohms max.  
 Insulation Resistance @ 100 VDC ..... 100 megohms min.  
 Dielectric Withstanding Voltage ..... 250 VAC  
 Tracking Error .....  $\pm 2$  dB  
 Standard Taper ..... Linear, Audio  
 Power Rating  
 Linear ..... 0.2 watt  
 Audio ..... 0.1 watt  
 Slider Noise ..... 100 mV max.

### Environmental Characteristics

Operational Life ..... 100,000 cycles  
 TR Shift .....  $\pm 15$  %  
 Operating Temperature Range .....  $-10$  °C to  $+55$  °C  
 Resistance to Solder Heat.....  $\pm 5$  %

### Mechanical Characteristics

Mechanical Angle .....  $300$  °  $\pm 5$  °  
 Mechanical Travel..... Length  $\pm 0.5$  mm  
 Operating Force ..... 50 gf  
 Stop Strength ..... 5 kgf min.  
 Shaft Axial Force ..... 5 kgf min.  
 Shaft Wobble..  $2(2 \times L/25)$  mm p-p max.  
 Soldering Condition  
 Manual .....  $300$  °C  $\pm 5$  °C for 3 sec.  
 Wave .....  $260$  °C  $\pm 5$  °C for 5 sec.  
 Wash ..... Not recommended

### Standard Resistance Table

Resistance (Ohms)	Resistance Code
1,000	102
2,000	202
5,000	502
10,000	103
20,000	203
50,000	503
100,000	104
200,000	204
500,000	504
1,000,000	105

### Product Dimensions

#### 45 mm Length of Travel Lever End Style "B"

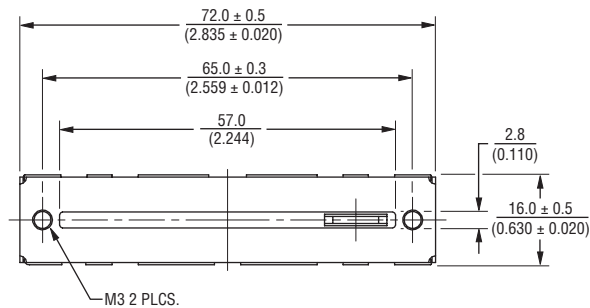

Lever Length
15.0 (.591)
20.0 (.787)

DIMENSIONS:  $\frac{\text{MM}}{\text{(INCHES)}}$

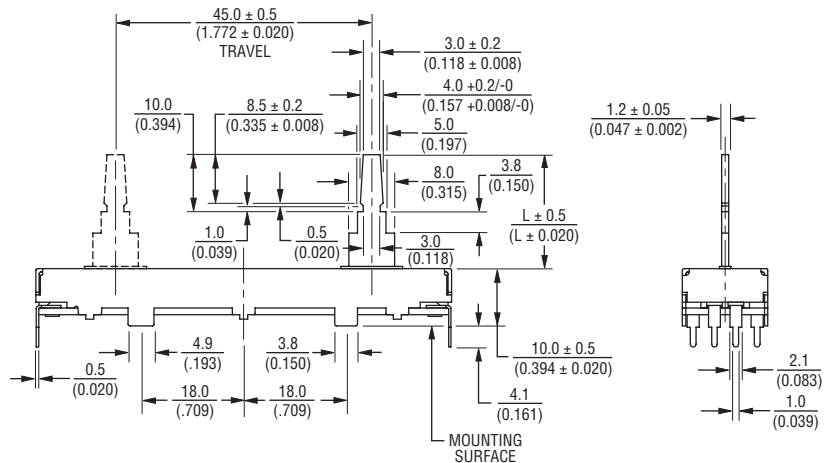

#### Mounting Hole Detail

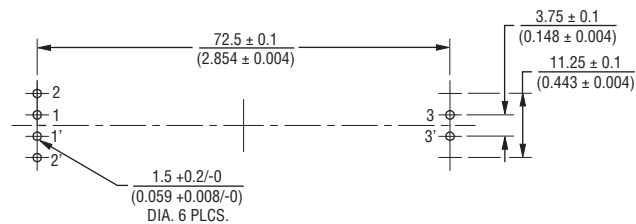

### Schematics

#### Single Gang

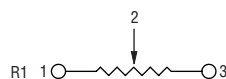

#### Dual Gang

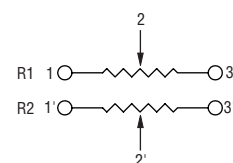

\*RoHS Directive 2002/95/EC Jan 27 2003 including Annex  
 Specifications are subject to change without notice.  
 Customers should verify actual device performance in their specific applications.

## Applications

- Mixing consoles
- Drum machines
- Keyboards and synthesizers
- Equalizers

# PTE Series Low Profile Slide Potentiometer

# BOURNS®

## Product Dimensions

### 60 mm Length of Travel Lever End Style "A"

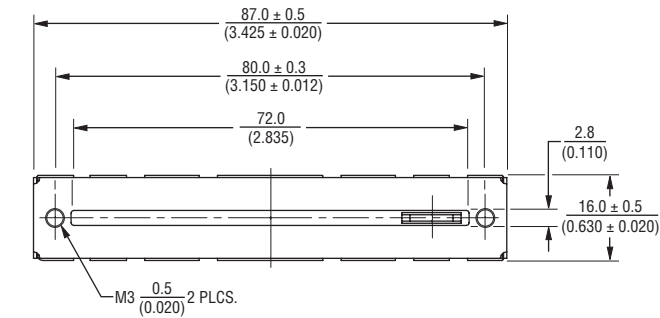

Lever Length	
15.0	(.591)
20.0	(.787)

DIMENSIONS:  $\frac{\text{MM}}{\text{(INCHES)}}$

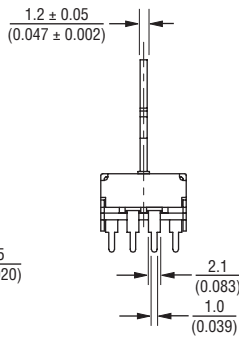
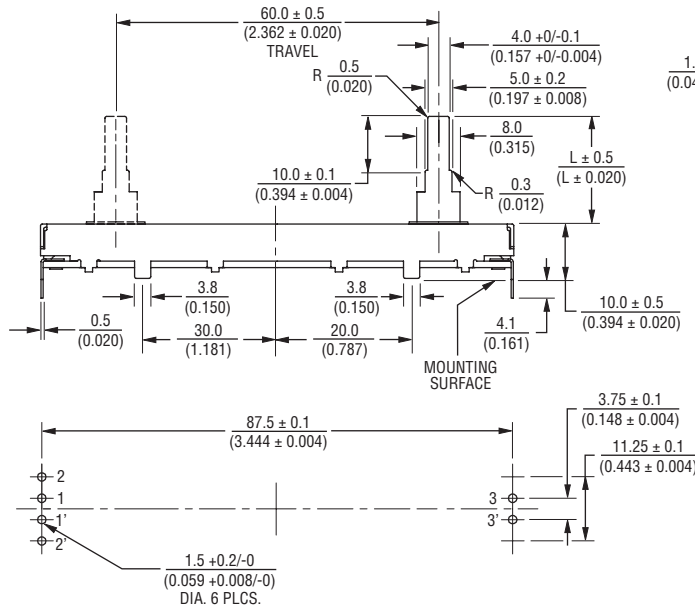

## Tapers

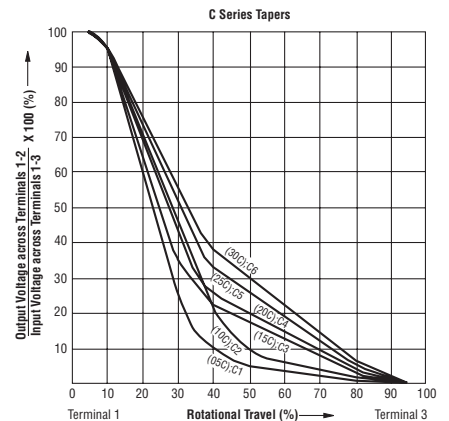
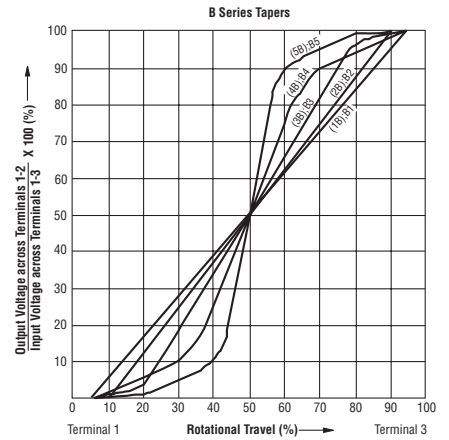
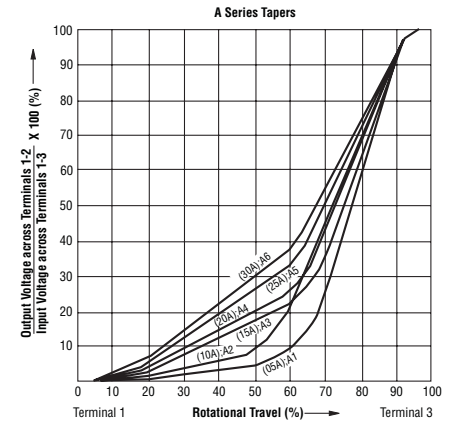

Specifications are subject to change without notice.  
Customers should verify actual device performance in their specific applications.

# PTE Series Low Profile Slide Potentiometer

# BOURNS®

## Additional Lever End Styles

## How To Order

### Lever End Style "C"

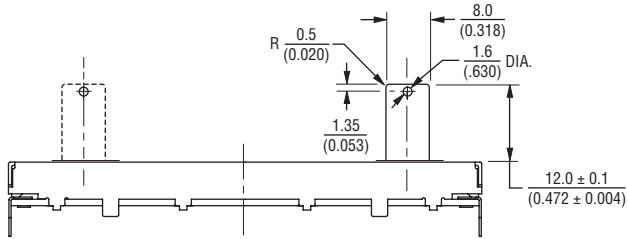

DIMENSIONS:  $\frac{\text{MM}}{\text{(INCHES)}}$

### Lever End Style "D"

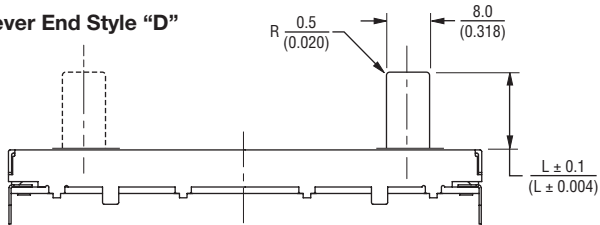

Lever Length
$\frac{12.8}{(.504)}$
$\frac{20.0}{(.787)}$

### Lever End Style "E"

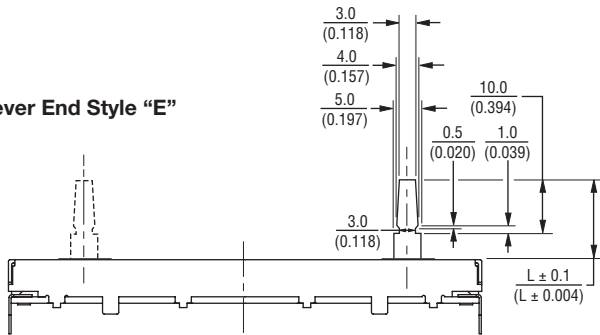

Lever Length
$\frac{15.0}{(.591)}$
$\frac{20.0}{(.787)}$

**PTE 45 - 15 2 A - 103 B2**

Model Number \_\_\_\_\_

Designator \_\_\_\_\_  
 PTE = Low Profile  
 Slide  
 Potentiometer

Length of Travel \_\_\_\_\_  
 45 = 45 mm  
 60 = 60 mm

Lever Length \_\_\_\_\_  
 12 = 12 mm (Available with  
 Lever End Style C)  
 13 = 12.8 mm (Available with  
 Lever End Style D)  
 15 = 15 mm (Available with  
 Lever End Styles A,B,E)  
 20 = 20 mm (Available with  
 Lever End Styles A,B,D,E)

No. of Gangs \_\_\_\_\_  
 1 = Single Gang  
 2 = Dual Gang

Metal Lever End Style \_\_\_\_\_  
 (Refer to Drawings)  
 • A • D  
 • B • E  
 • C

Resistance Code \_\_\_\_\_  
 (See Standard Resistance Table)

Resistance Taper (See Taper Charts) \_\_\_\_\_  
 Taper Series followed by Curve Number

REV. 02/10

Specifications are subject to change without notice.  
 Customers should verify actual device performance in their specific applications.

## X-ON Electronics

Largest Supplier of Electrical and Electronic Components

*Click to view similar products for [Slide Potentiometers](#) category:*

*Click to view products by [Bourns](#) manufacturer:*

Other Similar products are found below :

[M22](#) [SS-4928](#) [RSA0K11A901L](#) [RA6020F-10-20D1-B50K](#) [RA4520F-10-20D1-B50K](#) [X22205CAAF](#) [RSA0N11B9A03](#) [448XC2103BDN](#)  
[K22208EAAG](#) [PS15-10PC1BR10K](#) [3048L-2-503](#) [MFP 211-N](#) [CDE23N-60-B10K](#) [CDE23N-60-B1K](#) [CDE23N-60-B50K](#) [1825160-1](#)  
[1825161-2](#) [1825257-1](#) [1825259-2](#) [1825261-2](#) [X22205AAAL](#) [PS100-2B1AR10K](#) [1825255-5](#) [PTA6044-2015CPB103](#) [PTA6044-2015CPB104](#)  
[PTA6044-2015CPA103](#) [PTA6044-2015CPA104](#) [PS100-1B1BR10K](#) [PTA3044-2015CPB504](#) [RS15H113CA05](#) [PS20-10PC1BR10K](#)  
[RS08U11AZ001](#) [RA4520F-10-20D1-B1K](#) [PTL30-15R0-104B2](#) [PTE60-202B-102B2](#) [PTA6044-2015DPB103](#) [RA6020F-10-20D1-B100K](#)  
[RA6020F-10-15F2-B2K](#) [RA4543F-20-15D1-B10K-01](#) [RA3043F-20-10EB1-A100K](#) [RA6043F-20-10EB1-A5K](#) [RA6020F-10-20D1-B250K](#)  
[RA6020F-10-15F2-B5K](#) [RA6020F-10-15F2-B1K](#) [RA00B1MF-10-08T1-JISB10K-016](#) [RA60K1F-10-13D1-B100K-011](#) [RA3043F-20-10EB1-](#)  
[A50K](#) [RA4520F-10-20D1-B5K](#) [SX254](#) [CDE23N-60-B5K](#)