

## Electrostatic Discharged Protection Devices (ESD) Data Sheet

### Description

Brightking's SET23AXXL02 series of transient voltage suppressor (TVS) are designed to protect components which are connected to data and transmission lines from voltage surges caused by electrostatic discharge (ESD), electrical fast transients (EFT) and lightning.

TVS diodes are characterized by their high surge capability, low operating and clamping voltages, and fast response time. This makes them ideal for use as board level protection of sensitive semiconductor components.

The low profile SOT-23 package allows flexibility in the design of crowded circuit boards.



Contact :  $\pm 8\text{kV}$   
Air :  $\pm 15\text{kV}$



### Features

- IEC61000-4-2 ESD 15KV Air, 8KV contact compliance
- SOT-23 surface mount package
- Protects one bidirectional line or two unidirectional lines
- Working voltage: 3.3V, 5V, 12V, 15V, 24V and 36V
- Low leakage current
- Low operating and clamping voltages
- Solid-state silicon avalanche technology
- Lead Free/RoHS compliant
- Solder reflow temperature: Pure Tin-Sn, 260~270°C
- Flammability rating UL 94V-0
- Meets MSL level 1, per J-STD-020

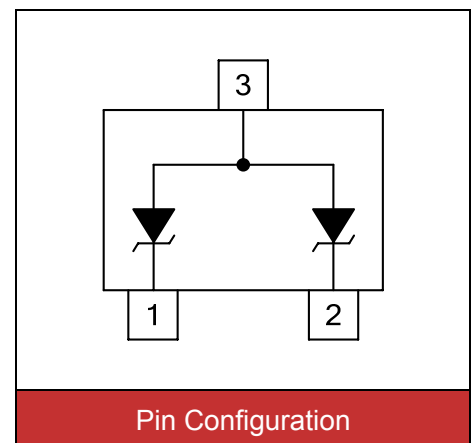

### Applications

- Cellular handsets and accessories
- Personal digital assistants (PDA's)
- Portable instrumentation
- Set Top Box (STB)
- Servers, notebook, and desktop PC
- Wireless bus protection
- RS-232, RS-422, RS-423 protection

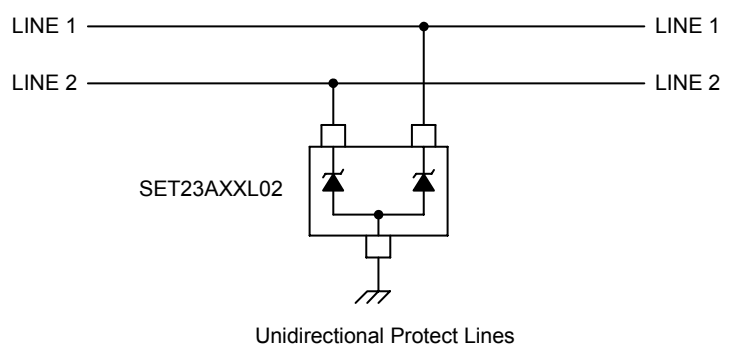
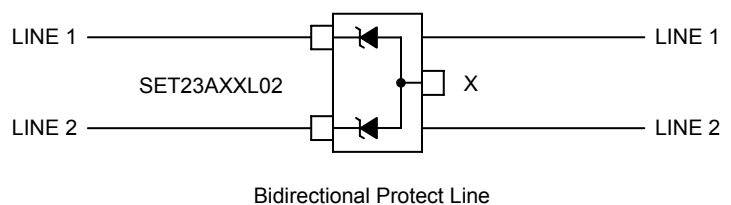

**Maximum Ratings**

Rating	Symbol	Value	Unit
ESD voltage (Contact discharge)	$V_{ESD}$	$\pm 8$	kV
ESD voltage (Air discharge)		$\pm 15$	
Storage & operating temperature range	$T_{STG}, T_J$	-55~+150	°C

**Electrical Characteristics ( $T_J=25^{\circ}\text{C}$ )**

SET23A03L02 (Marking: B 03C)

Parameter	Symbol	Condition	Min.	Typ.	Max.	Unit
Reverse stand-off voltage	$V_{RWM}$				3.3	V
Reverse breakdown voltage	$V_{BR}$	$I_{BR}=1\text{mA}$	4			V
Reverse leakage current	$I_R$	$V_R=3.3\text{V}$ Each I/O pin			5	$\mu\text{A}$
Clamping voltage ( $t_p=8/20\mu\text{s}$ )	$V_C$	$I_{PP}=1\text{A}$			7.5	V
Clamping voltage ( $t_p=8/20\mu\text{s}$ )	$V_C$	$I_{PP}=10\text{A}$			15	V
Off state junction capacitance	$C_J$	0Vdc, f=1MHz Between I/O pins and GND		200		pF

SET23A05L02 (Marking: B 05C)

Parameter	Symbol	Condition	Min.	Typ.	Max.	Unit
Reverse stand-off voltage	$V_{RWM}$				5	V
Reverse breakdown voltage	$V_{BR}$	$I_{BR}=1\text{mA}$	6			V
Reverse leakage current	$I_R$	$V_R=5\text{V}$ Each I/O pin			5	$\mu\text{A}$
Clamping voltage ( $t_p=8/20\mu\text{s}$ )	$V_C$	$I_{PP}=1\text{A}$			9.8	V
Clamping voltage ( $t_p=8/20\mu\text{s}$ )	$V_C$	$I_{PP}=15\text{A}$			20	V
Off state junction capacitance	$C_J$	0Vdc, f=1MHz Between I/O pins and GND		220		pF

**Electrical Characteristics ( $T_J=25^{\circ}\text{C}$ )**
**SET23A12L02 (Marking: B 12C)**

Parameter	Symbol	Condition	Min.	Typ.	Max.	Unit
Reverse stand-off voltage	$V_{RWM}$				12	V
Reverse breakdown voltage	$V_{BR}$	$I_{BR}=1\text{mA}$	13.3			V
Reverse leakage current	$I_R$	$V_R=12\text{V}$ Each I/O pin			1	$\mu\text{A}$
Clamping voltage ( $t_p=8/20\mu\text{s}$ )	$V_C$	$I_{PP}=1\text{A}$			19	V
Clamping voltage ( $t_p=8/20\mu\text{s}$ )	$V_C$	$I_{PP}=10\text{A}$			25.9	V
Off state junction capacitance	$C_J$	0Vdc, f=1MHz Between I/O pins and GND		100		pF

**SET23A15L02 (Marking: B 15C)**

Parameter	Symbol	Condition	Min.	Typ.	Max.	Unit
Reverse stand-off voltage	$V_{RWM}$				15	V
Reverse breakdown voltage	$V_{BR}$	$I_{BR}=1\text{mA}$	16.7			V
Reverse leakage current	$I_R$	$V_R=15\text{V}$ Each I/O pin			1	$\mu\text{A}$
Clamping voltage ( $t_p=8/20\mu\text{s}$ )	$V_C$	$I_{PP}=1\text{A}$			24	V
Clamping voltage ( $t_p=8/20\mu\text{s}$ )	$V_C$	$I_{PP}=10\text{A}$			30	V
Off state junction capacitance	$C_J$	0Vdc, f=1MHz Between I/O pins and GND		90		pF

**SET23A24L02 (Marking: B 24C)**

Parameter	Symbol	Condition	Min.	Typ.	Max.	Unit
Reverse stand-off voltage	$V_{RWM}$				24	V
Reverse breakdown voltage	$V_{BR}$	$I_{BR}=1\text{mA}$	26.7			V
Reverse leakage current	$I_R$	$V_R=24\text{V}$ each I/O pin			1	$\mu\text{A}$
Clamping voltage ( $t_p=8/20\mu\text{s}$ )	$V_C$	$I_{PP}=1\text{A}$			43	V
Clamping voltage ( $t_p=8/20\mu\text{s}$ )	$V_C$	$I_{PP}=5\text{A}$			49	V
Off state junction capacitance	$C_J$	0Vdc, f=1MHz Between I/O pins and GND		80		pF

**Electrical Characteristics ( $T_J=25^{\circ}\text{C}$ )**

SET23A36L02 (Marking: B 36C)

Parameter	Symbol	Condition	Min.	Typ.	Max.	Unit
Reverse stand-off voltage	$V_{RWM}$				36	V
Reverse breakdown voltage	$V_{BR}$	$I_{BR}=1\text{mA}$	40			V
Reverse leakage current	$I_R$	$V_R=36\text{V}$ each I/O pin			1	$\mu\text{A}$
Clamping voltage ( $t_p=8/20\mu\text{s}$ )	$V_C$	$I_{PP}=1\text{A}$			51	V
Clamping voltage ( $t_p=8/20\mu\text{s}$ )	$V_C$	$I_{PP}=5\text{A}$			76.8	V
Off state junction capacitance	$C_J$	0Vdc, $f=1\text{MHz}$ Between I/O pins and GND		70		pF

**Typical Characteristics Curves**

Figure 1. Power Derating Curve

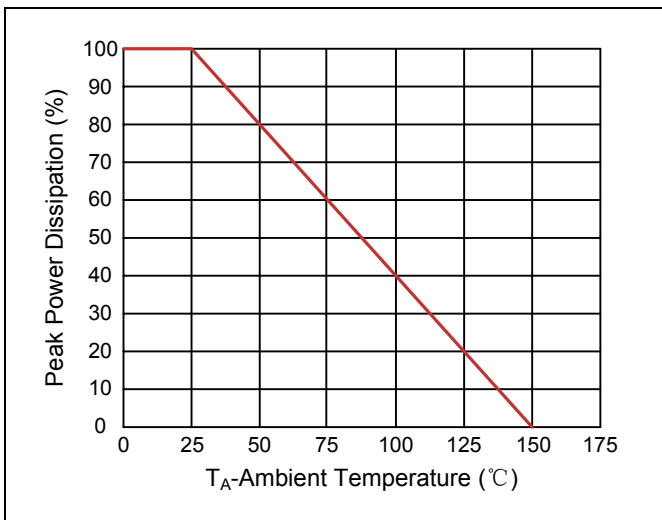

Figure 2. Pulse Waveforms

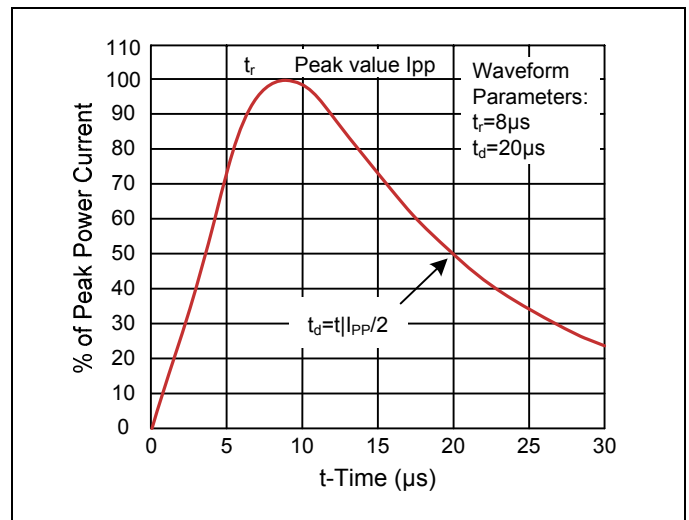

Figure 3. Forward Voltage vs. Forward Current

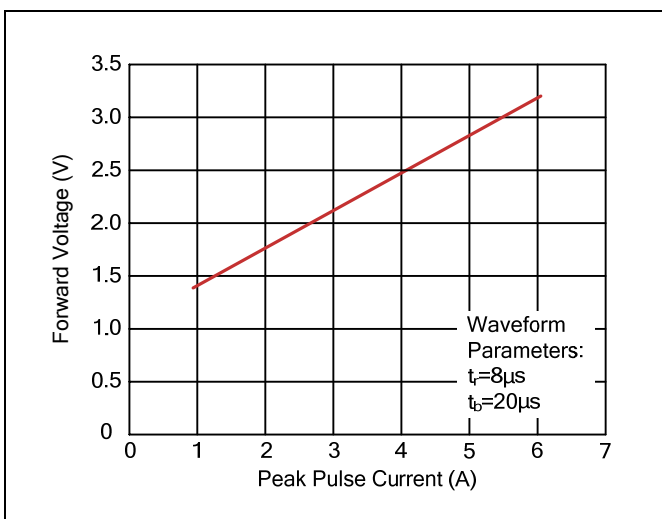
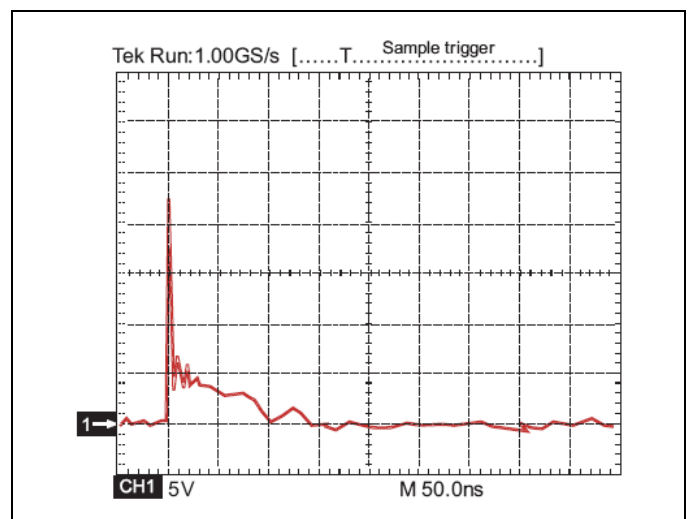

Figure 4. ESD Clamping(8kV Contact IEC61000-4-2)



**Recommended Soldering Conditions**

Reflow Soldering



Recommended Conditions

Profile Feature	Pb-Free Assembly
Average ramp-up rate ( $T_L$ to $T_P$ )	3°C/second max.
Preheat -Temperature Min ( $T_{S\ min}$ ) -Temperature Max ( $T_{S\ max}$ ) -Time (min to max) ( $t_s$ )	150°C 200°C 60-180 seconds
$T_{S\ max}$ to $T_L$ -Ramp-up Rate	3°C/second max.
Time maintained above: -Temperature ( $T_L$ ) -Time ( $t_L$ )	217°C 60-150 seconds
Peak Temperature ( $T_P$ )	260°C
Time within 5°C of actual Peak Temperature ( $t_P$ )	20-40 seconds
Ramp-down Rate	6°C/second max.
Time 25°C to Peak Temperature	8 minutes max.

**Dimensions (SOT-23)**

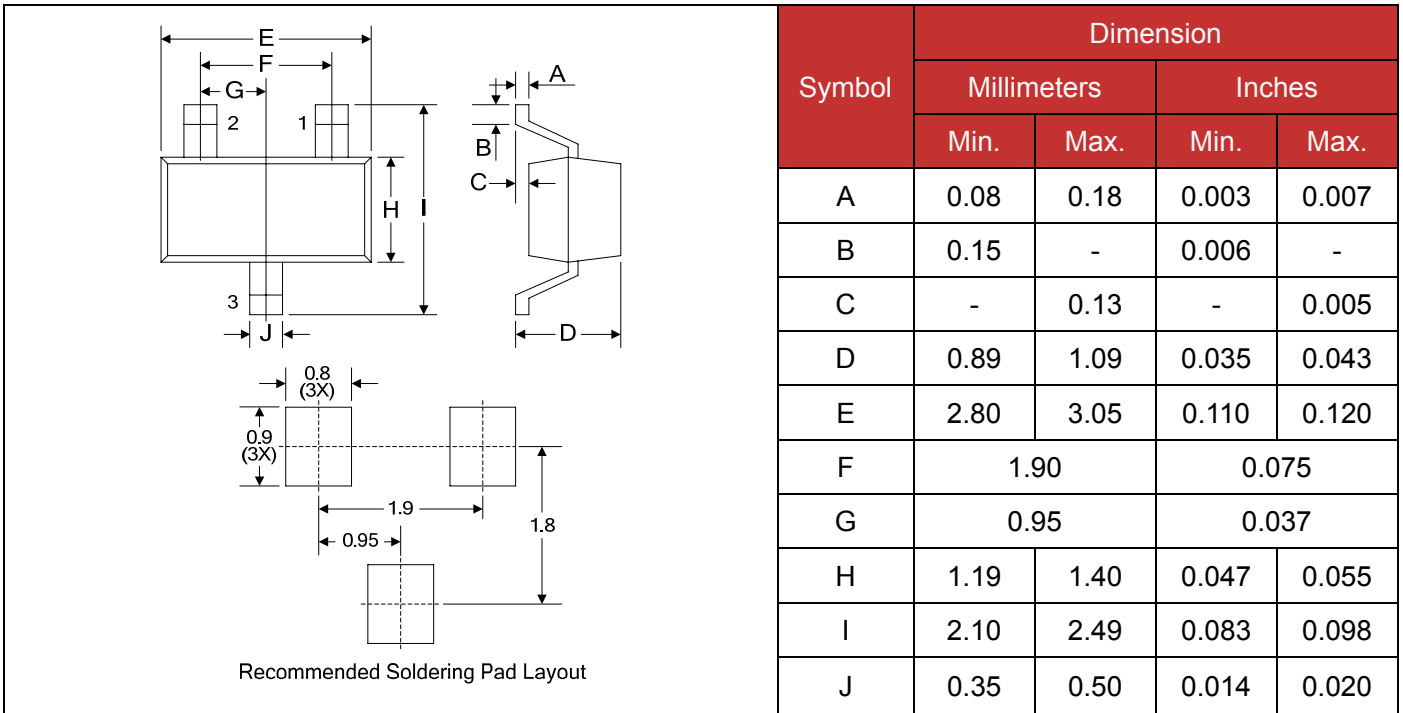

**Packaging**

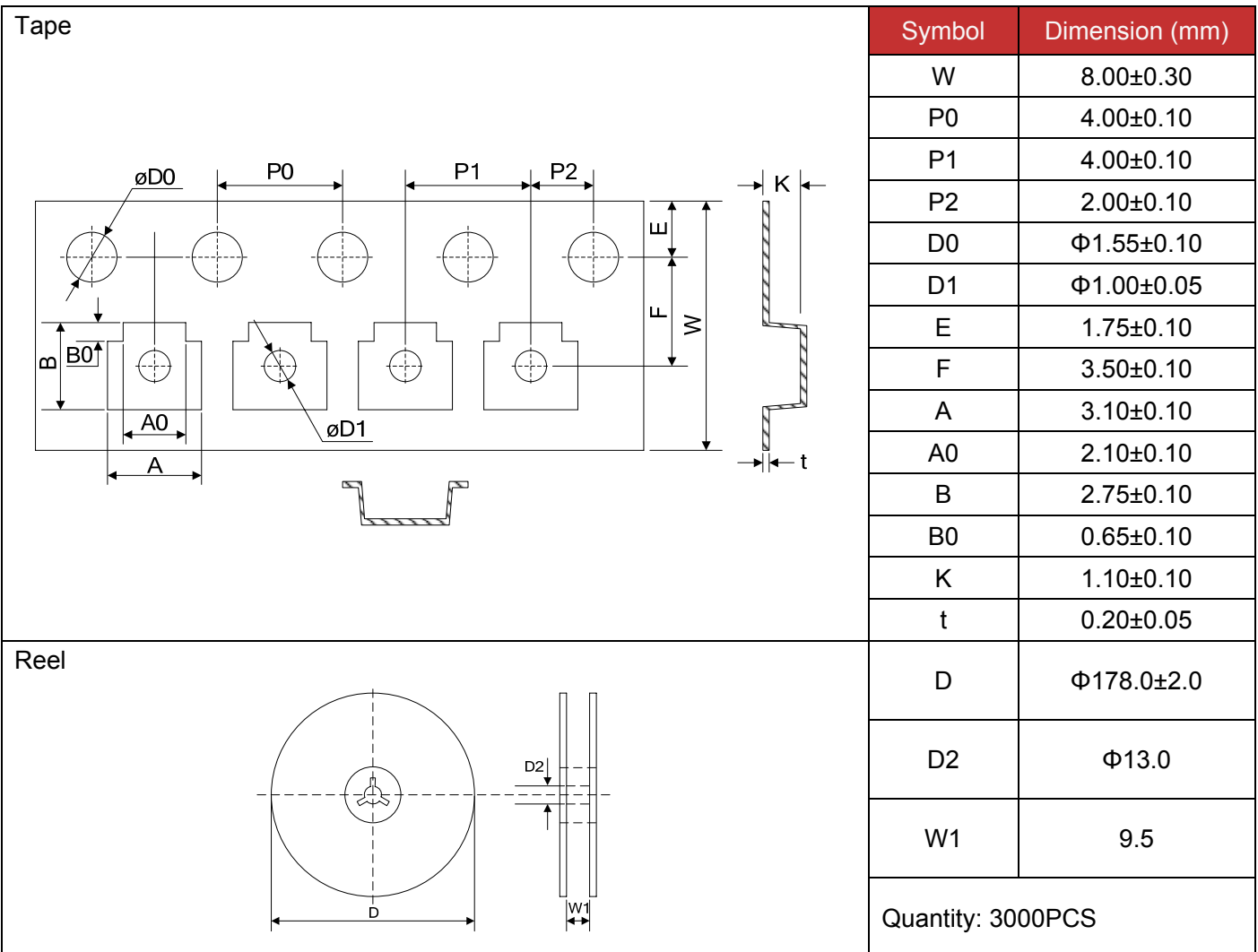

## X-ON Electronics

Largest Supplier of Electrical and Electronic Components

*Click to view similar products for [ESD Suppressors / TVS Diodes](#) category:*

*Click to view products by [Brightking](#) manufacturer:*

Other Similar products are found below :

[NTE4902](#) [P4SMAJ15A](#) [P4SMAJ26A](#) [SMAJ400CA-TP](#) [TGL34-47CA](#) [ESDAULC45-1BF4](#) [SM1605E3/TR13](#) [SMF20A-TP](#) [P4SMAJ12A](#)  
[CPDUR24V-HF](#) [CPDQC5V0USP-HF](#) [CPDQC5V0-HF](#) [MPLAD30KP45CAE3](#) [MMBZ27VCLQ-7-F](#) [MMAD1108/TR13](#) [MPLAD30KP24A](#)  
[ACPDQC5V0R-HF](#) [DFLT170A-7](#) [NTE4900](#) [NTE4926](#) [NTE4938](#) [SMF22A-TP](#) [SMF12A-TP](#) [SLVU2.8-TP](#) [SMLJ6.5CA-TP](#) [SMAJ6.5CA-](#)  
[TP](#) [MMAD1108E3/TR13](#) [D5V0M1U2LP3-7](#) [SMAJ400A-TP](#) [AOZ8811DT-03](#) [AOZ8831DI-05](#) [AOZ8831DT-03](#) [SMAJ188CA](#) [3SMC33CA](#)  
[BK](#) [CPDQC3V3C-HF](#) [CPDQC12VE-HF](#) [MPLAD30KP170CA](#) [82357120100](#) [5.0SMLJ15CA-TP](#) [5KP18A-TP](#) [P6KE8.2A-TP](#)  
[MPLAD30KP43CAE3](#) [SMAJ43A-TP](#) [D5V0F6U8LP33-7](#) [TVS5501V10MUT5G](#) [5.0SMLJ24CA-TP](#) [SMAJ110CA-TP](#) [MPLAD15KP75CAE3](#)  
[MMAD1103e3/TR13](#) [DFLT40AQ-7](#)